

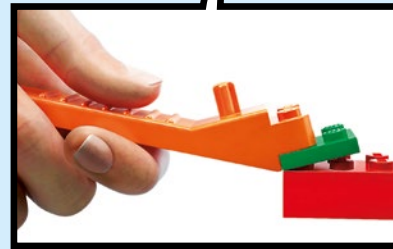

CREATOR™

10265

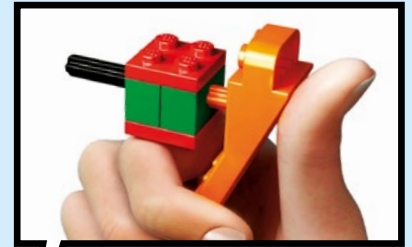

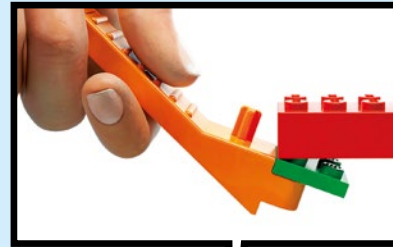

LEGO.com/brickseparator

1



2



3

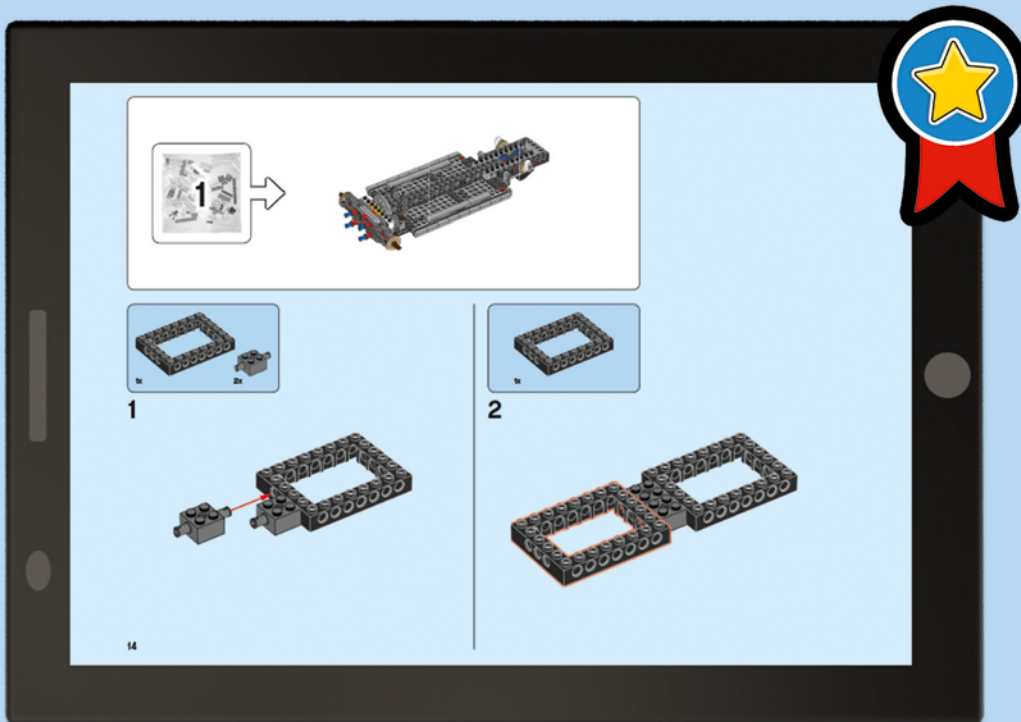

LEGO.com/apps

Check for compatibility
Vérifier la compatibilité
Comprueba tu compatibilidad



“Ford Motor Company is an American icon, and Mustang is an icon for all of Ford. If there is one product that represents our company, it’s the Mustang. It’s a legend because it’s beautiful, fast and affordable. There’s nothing else out there like it – nothing combines those three attributes the way Mustang does.”

I think people are so passionate about Mustang because it gives you a sense of freedom. I’ve always said if I could only own one car for the rest of my life, it would be a red Mustang convertible with a V-8 engine. It doesn’t get any better than that.”

Bill Ford Jr. Chairman, Ford Motor Company

« Ford Motor Company est une marque américaine emblématique, et la Mustang est une icône pour l’ensemble de Ford. S’il y a un produit qui représente notre entreprise, c’est bien la Mustang. C’est une légende parce qu’elle est belle, rapide et abordable. Elle est incomparable – rien ne combine ces trois attributs comme le fait la Mustang.»

Je pense que si les gens sont passionnés à ce point par la Mustang, c’est parce qu’elle donne un sentiment de liberté. J’ai toujours dit que si je ne pouvais posséder qu’une seule voiture pour le reste de ma vie, ce serait une Mustang décapotable rouge avec un moteur V-8. On ne peut pas rêver mieux que cela. »

Bill Ford Jr. Président, Ford Motor Company

“Ford Motor Company es un símbolo de Estados Unidos, y el Mustang es un símbolo dentro de Ford. Si hay un producto que represente a nuestra compañía, es el Mustang. Es una leyenda porque es hermoso, rápido y económico. No hay nada por ahí que se le parezca; nada combina esos tres atributos como el Mustang.”

Creo que a la gente le apasiona tanto el Mustang porque te permite sentirte libre. Siempre he dicho que, si sólo pudiera tener un auto por el resto de mi vida, sería un Mustang rojo convertible con motor V-8. Es lo mejor que hay”.

Bill Ford Jr. Presidente de Ford Motor Company



WELCOME TO THE START OF YOUR MUSTANG STORY!

One of the most iconic cars of the last 50 years, the Ford Mustang is one of the most recognizable cars in the world. But did you know it's also one of the most customizable?

Your LEGO® model represents what's made Mustang connect with its owners and fans for so many years – a fun, stylish, sporty car that was 'Designed to Be Designed by You'. In other words, Mustang owners are not only known to mix and match

options so that it's rare to see two together exactly alike, but also to shop the aftermarket to personalize their cars.

The Mustang's ability to build a truly personal – almost emotional – connection with owners has helped make it a huge success across generations. And now it's your turn to tell the next chapter in the Mustang story.

BIENVENUE AU DÉBUT DE VOTRE HISTOIRE MUSTANG !

Figurant parmi les voitures les plus emblématiques des 50 dernières années, la Ford Mustang est l'une des plus reconnaissables dans le monde. Mais saviez-vous que c'est aussi une des plus personnalisables ?

Votre modèle LEGO® représente ce qui lie la Mustang avec ses propriétaires et amateurs depuis de nombreuses années : une voiture amusante, élégante et sportive qui a été « conçue pour que vous la personnalisiez ». Autrement dit, les propriétaires de

Mustang sont non seulement connus pour varier les options, ce qui fait qu'il est rare de voir deux modèles exactement pareils l'un à côté de l'autre, mais aussi parce qu'ils achètent des pièces du marché secondaire pour personnaliser leurs voitures.

La capacité de la Mustang à créer un lien vraiment personnel – presque émotionnel – avec les propriétaires a contribué à son énorme succès au fil des générations. Et maintenant, c'est à votre tour d'écrire le prochain chapitre de l'histoire de la Mustang.

¡TE DAMOS LA BIENVENIDA AL PRINCIPIO DE TU AVENTURA CON EL MUSTANG!

Uno de los automóviles más representativos de los últimos 50 años, el Ford Mustang es también uno de los más populares del mundo. ¿Pero sabías que es también uno de los que más opciones ofrece?

Tu modelo LEGO® es todo lo que ha permitido al Mustang conectar con sus propietarios y fans durante tantos años: un vehículo divertido, elegante y deportivo, diseñado para ser diseñado por ti, tal como dice el popular eslogan. Dicho de otro modo, quienes conducen un

Mustang no sólo mezclan y combinan opciones (hasta tal punto que es raro ver dos modelos juntos exactamente iguales), sino que compran también partes de otros fabricantes para personalizar sus autos.

La capacidad del Mustang para establecer una conexión verdaderamente personal (y casi sentimental) con su propietario ha sido una de las claves de su enorme éxito a lo largo de varias generaciones. Ahora te toca a ti escribir el próximo capítulo de la historia del Mustang.



Presenting the unexpected...
New Ford Mustang!



This is the car you never expected from Detroit. It is so distinctively beautiful it has received the Tiffany Award for Excellence in American Design, the first automobile ever to be so honored by Tiffany & Co. Mustang has the look, the fire, the flavor of one of the great European road cars. Yet it is as American as its name . . . and as practical as its price. Because Mustang is an amazingly versatile car and can be inexpensively tailored to the widest variety of individual tastes, many very different people will find it surprisingly easy to say: "This is the ideal car for me." Turn the page and you'll see why.

A TRUE CROWD-PLEASER

The Ford Mustang was the result of efforts by several key Ford people – including product planner Hal Sperlich, chief engineer Don Frey, designers Gale Halderman and Joe Oros, as well as Ford Division VP Lee Iacocca – to develop and market an exciting new automobile with widespread appeal.

Sperlich interpreted research on the record numbers of leading-edge baby-boomers and college grads entering the workforce and car market, which indicated that they were looking for a fun-to-drive second family car. Iacocca wanted to attract those young buyers to Ford with a stylish yet affordable sports car that was also practical and attainable. Frey sought to engineer



a capable but economical vehicle that was easy to manufacture, all while Halderman and Oros wanted to style something fresh and different – something sporty and, at the same time, beautiful. When they were finally able to get the green light for production from then-Ford Chairman Henry Ford II, the rest, as they say, is history.

The Ford Mustang was so successful that its name and shape soon became identifiable the world over, and even led to the creation of the term 'Pony Car' for the segment of affordable, compact cars with a sporty or high-performance image that followed.

UNE GRANDE FAVORITE DU PUBLIC

La Ford Mustang est le résultat des efforts déployés par plusieurs personnes importantes chez Ford – y compris le responsable de la planification des produits Hal Sperlich, l'ingénieur en chef Don Frey, les concepteurs Gale Halderman et Joe Oros, ainsi que le vice-président de la division Ford Lee Iacocca – pour développer et commercialiser une nouvelle automobile palpitante exerçant un puissant attrait.

M. Sperlich a interprété des recherches sur les nombreux baby-boomers de la première vague et les diplômés de niveau postsecondaire qui arrivaient sur le marché du travail et de l'automobile. Ces recherches indiquaient qu'ils désiraient une deuxième voiture familiale amusante à conduire. M. Iacocca a voulu attirer les jeunes acheteurs vers Ford avec une voiture de sport élégante et abordable qui était aussi pratique et accessible. M. Frey avait envie de concevoir un véhicule efficace et économique qui serait facile à fabriquer, alors que M. Halderman et M. Oros voulaient quelque chose d'original et de différent, qui serait à la fois sportif et magnifique. Lorsqu'ils ont enfin obtenu le feu vert du président Ford de l'époque, Henry Ford II, pour entamer la production, le reste, comme on dit, est passé à l'histoire.

La Ford Mustang a connu tant de succès que son nom et sa forme sont rapidement devenus reconnaissables dans le monde entier. Ils ont même mené à la création du terme « Pony Car » pour définir une nouvelle catégorie de voitures abordables et compactes d'allure sportive ou haute performance.

UN PLACER PARA TODO EL MUNDO

El Ford Mustang fue el resultado del trabajo de varios de los principales líderes de Ford, entre ellos Hal Sperlich (planificador de productos), Don Frey (ingeniero jefe), Gale Halderman y Joe Oros (diseñadores), y Lee Iacocca (vicepresidente de la división Ford), quienes desarrollaron y comercializaron un nuevo y fascinante automóvil de gran atractivo para el público.

Sperlich fue el responsable de interpretar las cifras récord de *baby-boomers* y graduados universitarios que empezaban a incorporarse a los mercados laboral y automovilístico, deduciendo que buscaban un segundo auto familiar que fuera divertido de conducir. Iacocca quería atraer a esos jóvenes compradores hacia Ford con un auto deportivo elegante pero económico, que fuera también práctico y accesible. Frey se propuso crear un vehículo potente aunque costeable que fuera fácil de fabricar, mientras que Halderman y Oros perseguían algo fresco y diferente, deportivo y, al mismo tiempo, hermoso. Cuando por fin obtuvieron del entonces presidente de Ford, Henry Ford II, la autorización para iniciar la producción, el resto, como suele decirse, fue historia.

El Ford Mustang tuvo tanto éxito que su nombre y su forma se hicieron rápidamente identificables en todo el mundo, originando incluso el término *pony car*, que define el segmento de autos económicos y compactos con una línea deportiva o de alto desempeño al que dio paso.

THE BIRTH OF A LEGEND

Your LEGO® Creator Expert Ford Mustang is inspired by the classic 1967 Mustang. Featuring a long hood, short deck, optional V-8 engine and seating for four, the car made its public debut at the New York World's Fair on April 17, 1964 and was an instant hit. Mustang's total sales from 1964-1966 were a record-breaking 1,464,362 cars!

LA NAISSANCE D'UNE LÉGENDE

Votre Ford Mustang LEGO® Creator Expert est inspirée de la Mustang classique de 1967. Dotée d'un capot allongé, d'un plancher de carrosserie court, d'un moteur V-8 optionnel et d'assez de place pour quatre passagers, cette voiture a connu un succès instantané lorsqu'elle a fait sa première apparition publique à l'Exposition universelle de New York, le 17 avril 1964. Les ventes totales de la Mustang entre 1964 et 1966 ont atteint le record de 1 464 362 voitures !

EL NACIMIENTO DE UNA LEYENDA

Tu Ford Mustang LEGO® Creator Expert está inspirado en el clásico Mustang de 1967. Equipado con un largo cofre y cajuela corta, motor V-8 opcional y espacio para cuatro personas, el auto debutó públicamente en la Feria Mundial de Nueva York el 17 de abril de 1964 y fue un éxito instantáneo. ¡El Mustang batió todos los récords de ventas entre 1964 y 1966, alcanzando la cifra de 1.464.362 autos en total!

EVOLUTION OF AN ICON

According to J Walter Thompson's Frank Thomas, Ford's advertising account executive, the Mustang name was chosen because 'it had the excitement of the wide-open spaces and was American as all hell'. The next challenge was creating an emblem that captured that spirit. Now a true icon among car lovers the world over, here's the story of how the Mustang emblem evolved.

ÉVOLUTION D'UNE ICÔNE

Selon Frank Thomas de J Walter Thompson, l'organisateur des campagnes publicitaires de Ford, le nom « Mustang » a été choisi parce qu'« il représentait l'exaltation des grands espaces et était on ne peut plus américain ». Le défi suivant fut de créer un symbole qui capturerait ce sentiment. Alors qu'elle est maintenant une véritable icône chez les amateurs de voitures dans le monde entier, voici l'histoire de l'évolution de l'emblème de la Mustang.

LA EVOLUCIÓN DE UN ICONO

Según Frank Thomas, ejecutivo de J. Walter Thompson responsable de la cuenta publicitaria de Ford, se eligió el nombre Mustang porque "inspiraba la emoción que producían los espacios abiertos y era tan americano como el infierno". El siguiente desafío fue crear un emblema que capturara ese espíritu. Hoy convertido en un verdadero icono entre amantes del automóvil de todo el mundo, esta es la historia de la evolución del emblema del Mustang.



The goal was to create something that reflected both a horse for the car's name and that the car was American. Phil Clark's concept, of a galloping horse with a red, white and blue tri-bar design to reflect the Mustang's American heritage, was the initial favorite.

Le but était de concevoir quelque chose qui représenterait à la fois le cheval à l'origine du nom de la voiture et l'identité américaine de cette dernière. Le concept de Phil Clark, un cheval au galop avec un motif bleu, blanc et rouge à trois barres reflétant l'héritage américain de la Mustang, était initialement le favori.

El objetivo era crear algo que reflejara tanto la raza ecuestre cuyo nombre había adoptado el auto como el hecho de que se trataba de un auto americano. La idea de Phil Clark, un caballo al galope con tres barras de colores rojo, blanco y azul para plasmar el legado americano del Mustang, fue la favorita desde el principio.



The proportions of the original logo were deemed too tall to fit nicely in the production-style grille corral. Design studio modelers Charles Keresztes and Waino Kangas were tasked with creating new versions of the pony for the grille and fender of the Mustang II concept and the 1965 production car.

On jugeait que les proportions du logo original étaient trop grandes pour bien s'adapter au style de production de la calandre. Les modélisateurs du studio de création Charles Keresztes et Waino Kagas ont été chargés de créer de nouvelles versions du poney pour la calandre et le garde-boue du prototype de la Mustang II et de la voiture de série de 1965.

Sin embargo, las proporciones del logotipo original se consideraron demasiado altas como para caber en el espacio de la parrilla reservado para dicho elemento. Se encargó a Charles Keresztes y Waino Kangas, dos modelistas del estudio de diseño, que crearan nuevas versiones del caballo para la parrilla y las defensas del prototipo Mustang II y el auto que comenzó a fabricarse en 1965.



The production grille Pony emblem surrounded by the corral on the 1965 Mustang. Compared to Phil Clark's original design, this and subsequent versions of the pony show more of a running stance rather than galloping. The head and neck are more horizontal and the tail flows out behind.

La calandre de série sur la Mustang de 1965 comporte l'emblème du poney entouré par son corral. Comparées au concept original de Phil Clark, cette version du poney et les suivantes représentent plus une position de course que de galop. La tête et le cou sont plus à l'horizontale et la queue ondule derrière.

El emblema del caballo rodeado por el corral en la parrilla de un Mustang fabricado en 1965. Comparadas con el diseño original de Phil Clark, esta y las siguientes versiones del caballo lo muestran más en una postura de carrera que de galope. La cabeza y el cuello están más horizontales y la cola fluye al viento detrás.

'DESIGNED TO BE DESIGNED BY YOU'

One of the secrets behind the success of the Mustang is the seemingly infinite ways it can be customized according to the owner's desires. That's why the car's first advertising slogan was: 'Designed to be designed by you'.

The Mustang's option list was a major reason for its initial success. The car could be tailored to individual buyers - you could order a basic-transportation Mustang, a sporty one, a small luxury liner or a high-performance version.

Car Life magazine summed it up at the time: "It is a sports car,

a 'gran turismo' car, an economy car, a personal car, a rally car, a sprint car, a race car, a suburban car and even a luxury car."

The car was equally popular with both young and older buyers, though more than half of first-year buyers were under 34. Notably, women bought as many Mustang as men.



« CONÇUE POUR QUE VOUS LA PERSONNALISIEZ »

Un des secrets du succès de la Mustang est la manière apparemment infinie dont le propriétaire peut la personnaliser selon ses désirs. C'est pourquoi le premier slogan publicitaire de la voiture était : « conçue pour que vous la personnalisiez ».

La liste d'options de la Mustang a été l'une des principales raisons de son succès initial. La voiture pouvait être adaptée à chaque acheteur – on pouvait commander une Mustang de base ou sportive, un petit modèle de luxe ou une version haute performance.

À l'époque, le magazine *Car Life* l'a décrite comme ceci : « C'est une voiture économique et personnelle, c'est aussi une voiture

de sport, de tourisme, de rallye, de vitesse, de course, de banlieue et même de luxe. »

La voiture était tout aussi populaire auprès des jeunes que des personnes plus âgées, bien que plus de la moitié des acheteurs durant la première année avaient moins de 34 ans. Notons que les femmes ont acheté autant de Mustangs que les hommes.

“DISEÑADO PARA SER DISEÑADO POR TI”

Uno de los secretos detrás del éxito del Mustang son las aparentemente infinitas formas posibles de personalizarlo según los deseos de su propietario. Es por eso que el primer eslogan publicitario del auto fue: “Diseñado para ser diseñado por ti”.

La extensa lista de opciones del Mustang fue una de las principales causas de su éxito inicial. El auto se podía ajustar a los gustos de cada comprador: era posible encargar un Mustang básico de transporte, uno deportivo, un pequeño vehículo de lujo o una versión de alto desempeño.

Así lo explicaba la revista *Car Life* en su momento: “Es un auto deportivo, un gran turismo, un auto económico, un auto personal,

un auto de rallye, un auto para correr, un auto de competición, un auto suburbano e incluso un auto de lujo”.

El auto fue igualmente popular entre compradores jóvenes y de mayor edad, aunque más de la mitad de quienes lo compraron durante el primer año tenían menos de 34 años. Cabe destacar que las mujeres compraron tantos Mustang como los hombres.

THE COLOR OF LOVE

Over the years, red has established itself as the most popular color among Mustang owners. But it wasn't always that way... brown Mustang anyone?!

LA COULEUR DE L'AMOUR

Au cours des années, le rouge s'est imposé comme la couleur la plus populaire parmi les propriétaires de Mustang. Mais cela n'a pas toujours été le cas... une Mustang brune, ça vous dit ?!

EL COLOR DEL AMOR

A lo largo de los años, el rojo se ha consolidado como el color más popular entre los propietarios de un Mustang. Pero no siempre ha sido así... ¿alguien quiere un Mustang café?!

In 1967, pink enthusiasts could choose either Dusty Rose or Playboy Pink.

En 1967, les amateurs de rose pouvaient choisir les couleurs Dusty Rose ou Playboy Pink.

En 1967, los entusiastas del rosa pudieron elegir entre los colores Dusty Rose y Playboy Pink.



A grand total of 19 shades of blue were available between 1967 and 1973.

Un total de 19 teintes de bleu furent offertes entre 1967 et 1973.

Entre 1967 y 1973, fue posible elegir entre un total de 19 tonos de azul.



Black first broke into the top three in 1994 and has remained there since.

En 1994, le noir est devenu l'une des trois couleurs les plus en vogue et elle est restée au palmarès depuis.

El negro se coló por primera vez entre los tres primeros en 1994 y allí ha permanecido desde entonces.



Several special edition colors have been available over the years, including color-shifting Mystichrome on the 2004 SVT Cobra.

Plusieurs couleurs d'édition spéciale ont été offertes au cours des années, y compris la couleur changeante Mystichrome de la SVT Cobra 2004.

Ha sido posible elegir colores de edición especial en ciertas ocasiones, como sucedió con el multicolor Mystichrome del SVT Cobra de 2004.



1967

1973

1978

1994

2004

2014



YELLOW and GOLD were among the favorite colors in the first generation.

JAUNE et OR ont été parmi les couleurs préférées de la première génération.

Los colores amarillo y dorado fueron dos de los favoritos para la primera generación.



Maybe a little hard to believe today but brown was one of the top three colors back in the 70s.

C'est peut-être un peu difficile à croire aujourd'hui, mais le brun était l'une des trois couleurs les plus populaires dans les années 70.

Tal vez sea un poco difícil de creer hoy en día, pero el café fue uno de los tres colores más populares en la década de 1970.



Roughly one in five of all Mustangs built over the past 50 years have been painted RED.

Environ une Mustang sur cinq construite au cours des 50 dernières années est ROUGE.

Aproximadamente, uno de cada cinco Mustang fabricados en los últimos 50 años se ha pintado de rojo.



RED, BLACK and SILVER hold the top 3 color slots for nine years.

Le ROUGE, le NOIR et l'ARGENT ont été les couleurs prédominantes pendant neuf ans.

Durante nueve años consecutivos, el rojo, el negro y el plateado ocuparon los tres primeros lugares en la lista de colores más populares.

GET TO KNOW YOUR MUSTANG

APPRENEZ À CONNAÎTRE VOTRE MUSTANG

CONOCE TU MUSTANG



LEGO® Senior Designer Mike Psiaki played a leading role in the development of the LEGO Creator Expert Ford Mustang. He runs through some of the model's most fascinating features.

Le concepteur principal de LEGO® Mike Psiaki a joué un rôle primordial dans le développement de la Ford Mustang LEGO Creator Expert. Il passe ici en revue certaines des caractéristiques les plus fascinantes du modèle.

Mike Psiaki, diseñador sénior de LEGO®, desempeñó un papel destacado en el desarrollo del Ford Mustang LEGO Creator Expert. Aquí repasa algunos de los detalles y funciones más fascinantes del modelo.





TWO NEW ELEMENTS DEUX NOUVEAUX ÉLÉMENTS DOS NUEVOS ELEMENTOS



1. 2x8 Bow brick - designed to capture the streamlined curves of the roof and air intakes.

1. Brique courbée 2x8 - conçue pour reproduire les courbes du toit et l'entrée d'air.

1. Arco 2x8: diseñado para capturar las aerodinámicas curvas del techo y las tomas de admisión de aire.



2. 5-spoke wheel - designed to allow the steering function to fit inside the wheel for tighter turning.

2. Roue à cinq rayons - conçue pour permettre à la fonction de direction de rentrer dans la roue pour effectuer des virages plus serrés.

2. Rin de 5 radios: diseñado para que el mecanismo de dirección penetre dentro y sea posible girar más las ruedas.



A blue 2x4 brick – the core LEGO® building block – is used at the center of the big block V8 engine, the heart of the Ford Mustang.

Une brique 2x4 bleue – le bloc de construction LEGO® essentiel – est utilisée au centre du gros bloc moteur V8, le cœur de la Ford Mustang.

Un brick azul 2x4 (el bloque fundamental del sistema de construcción LEGO®) conforma el núcleo del motor V-8 de bloque grande: el corazón del Ford Mustang.

The doors fit seamlessly to the body when closed.

Lorsqu'elles sont fermées, les portes s'emboîtent parfaitement dans la carrosserie de la voiture.

Las puertas se ajustan perfectamente a la forma de la carrocería al cerrarlas.

The Shift-O-Matic transmission can click between different positions, just like on the real car.

La boîte de vitesses Shift-O-Matic peut être placée dans différentes positions, tout comme sur la vraie voiture.

La palanca de cambios Shift-O-Matic se puede colocar en diferentes posiciones, como en el auto de verdad.

Your Mustang features working front-wheel steering.

Votre Mustang est équipée d'un volant fonctionnel de direction avant.

Tu Mustang cuenta con mecanismo de dirección en las ruedas delanteras.

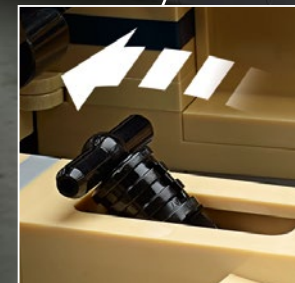

Turn the hidden wheel to lift
your Mustang!

Tournez la molette cachée pour
soulever votre Mustang !

¡Gira la rueda oculta para subir
el chasis de tu Mustang!



The German number plate
included with the car belonged
to LEGO® Senior Designer Adam
Grabowski who built one of the
early concept models of the car.

La plaque d'immatriculation
allemande incluse avec la voiture
appartenait au concepteur
principal de LEGO® Adam
Grabowski, qui a construit un
des premiers modèles.

La placa de matrícula alemana
que acompaña al auto perteneció
a Adam Grabowski, diseñador
sénior de LEGO®, a quien debemos
uno de los primeros prototipos
del modelo.

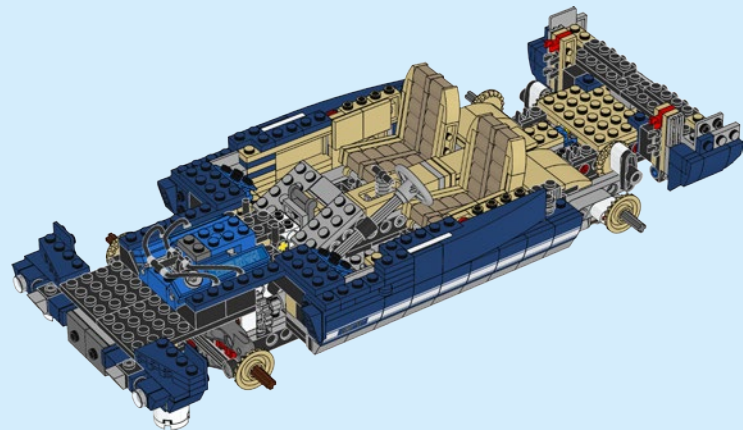
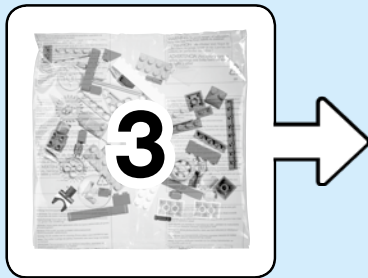
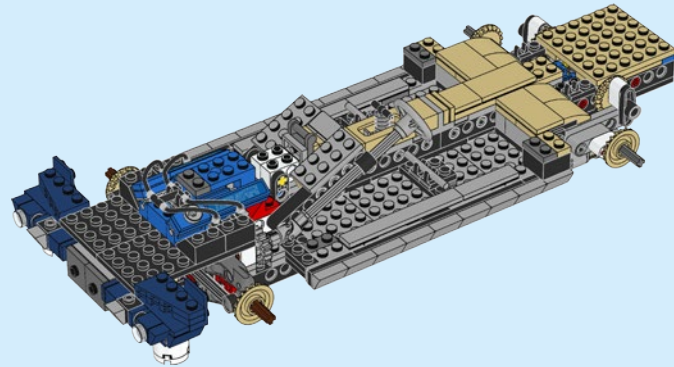
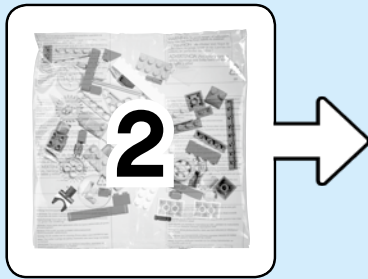
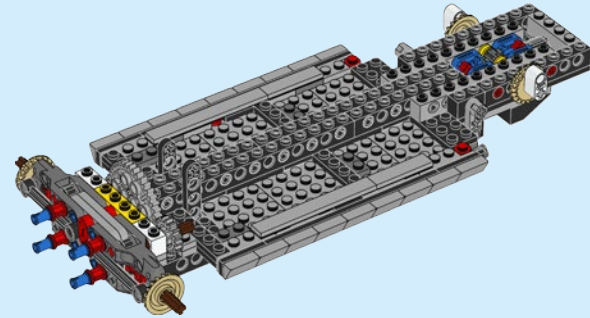
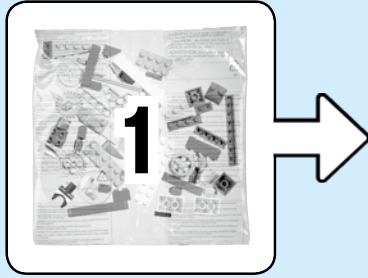

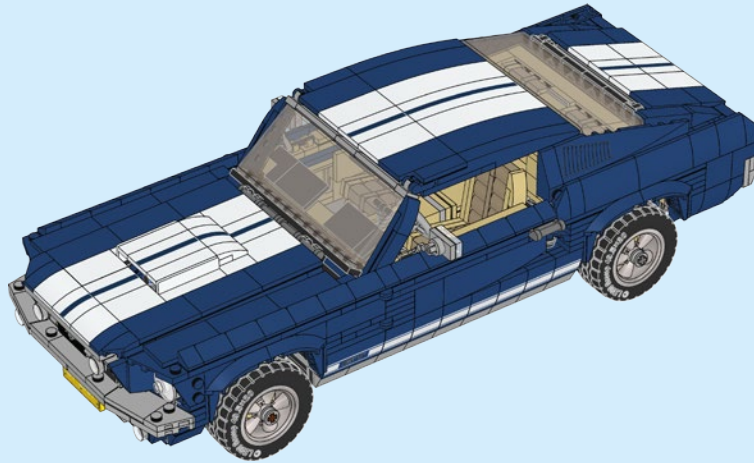
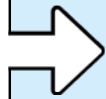
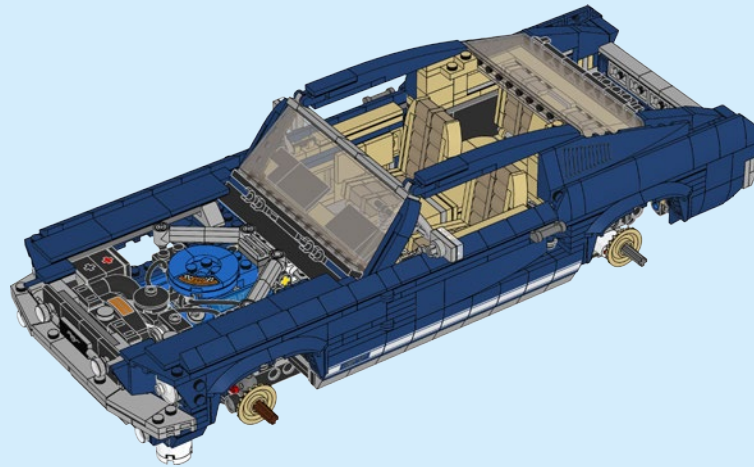
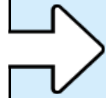
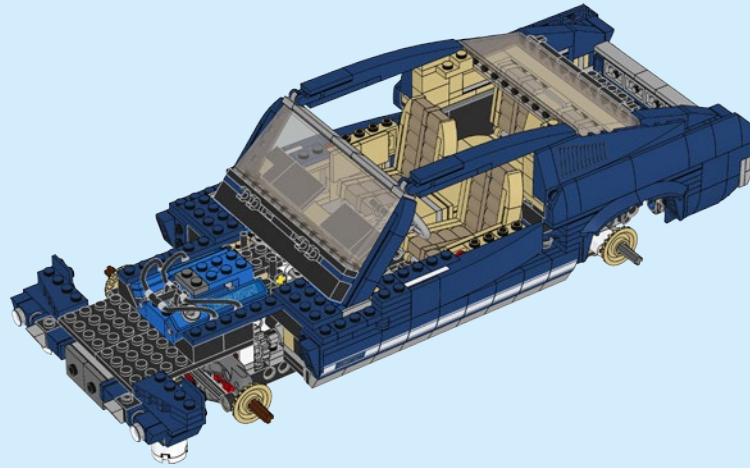
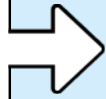
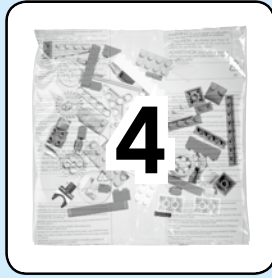

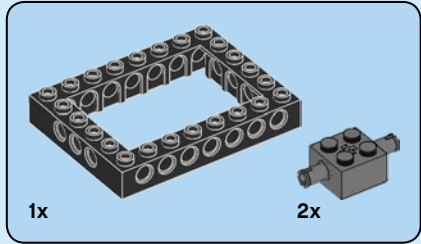
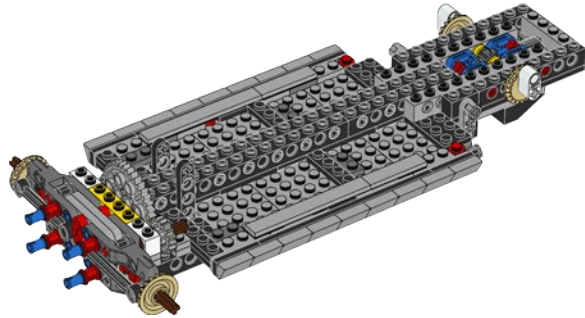
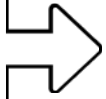

1

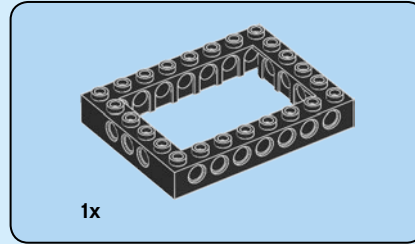
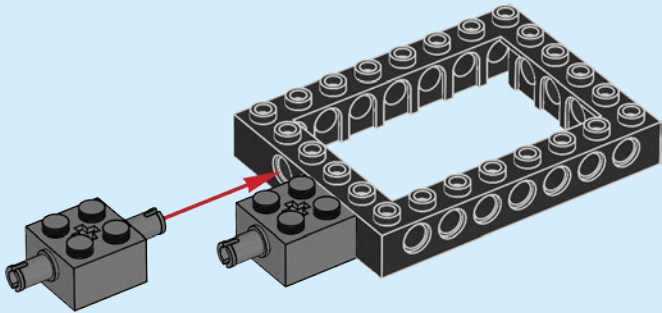

2

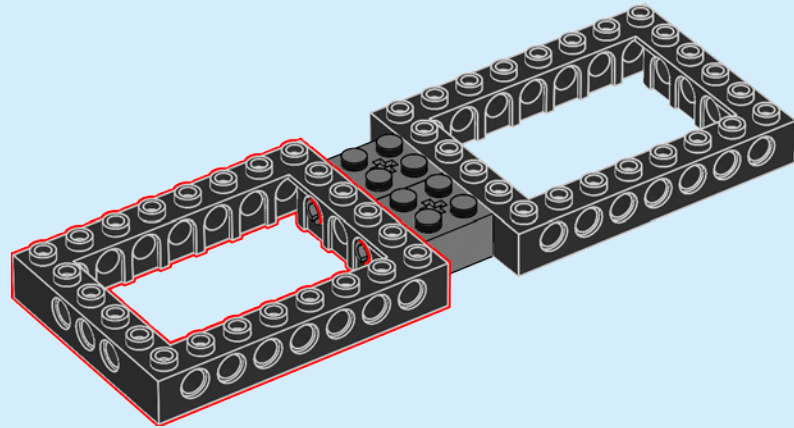

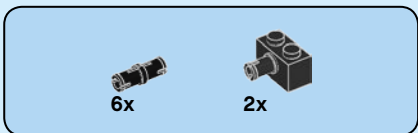

3

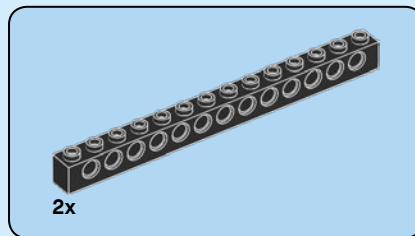
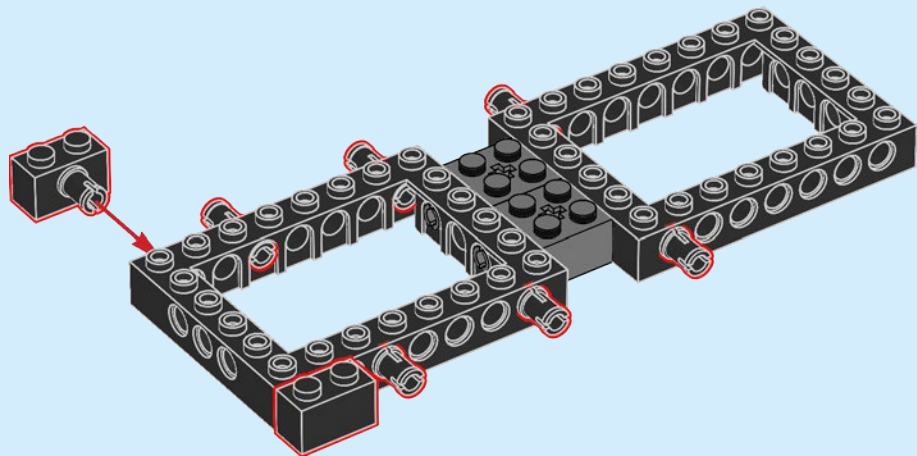

4

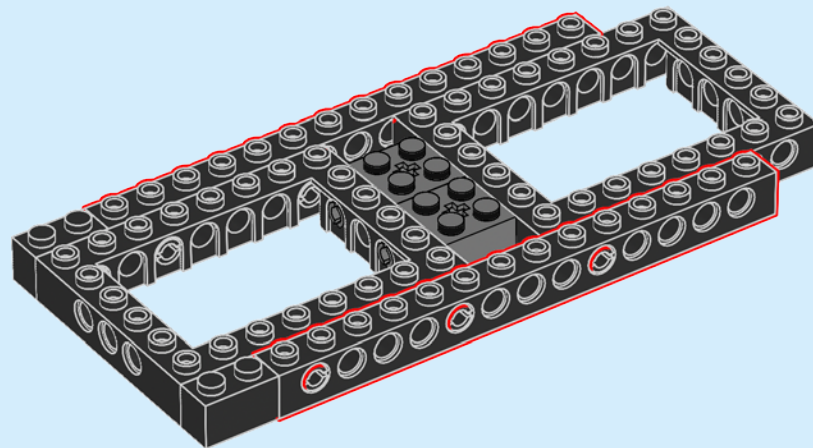

In 2007, Ford released a special pink version of the Mustang to help raise money to fight breast cancer.

En 2007, Ford a construit une Mustang en version spéciale rose pour aider à amasser des fonds pour la lutte contre le cancer du sein.

En 2007, Ford lanzó una versión especial del Mustang en color rosa para contribuir a la recaudación de fondos destinados a la lucha contra el cáncer de mama.

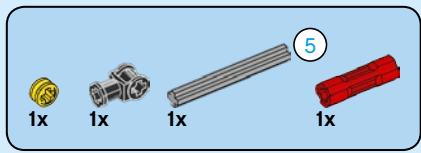

5

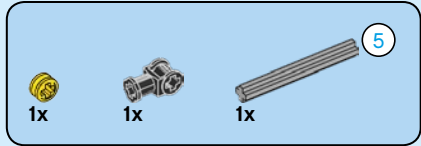
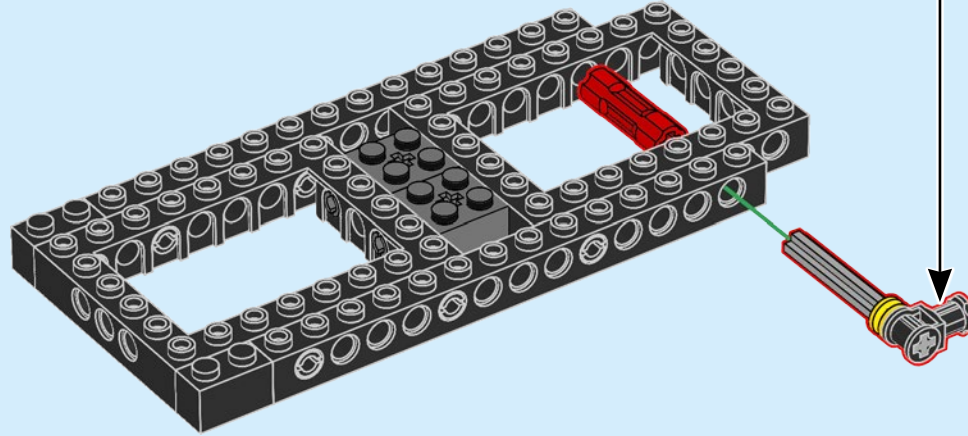
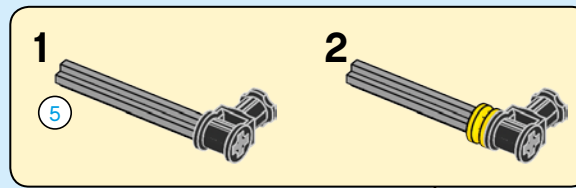
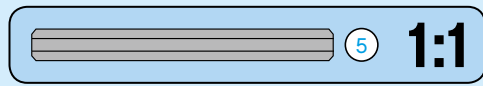

6

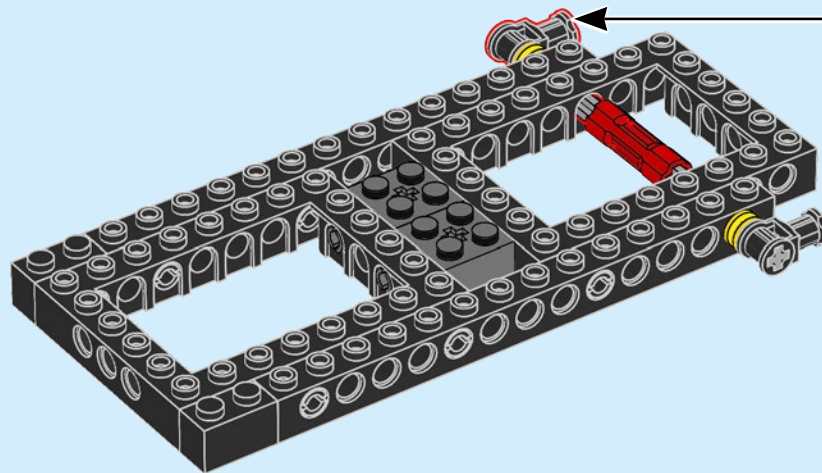
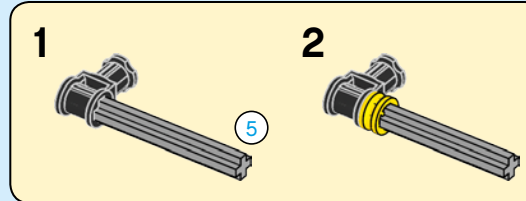

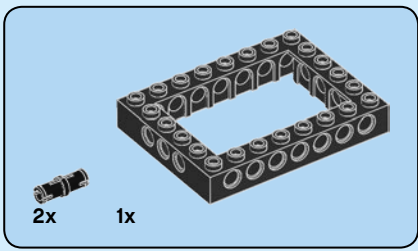

7

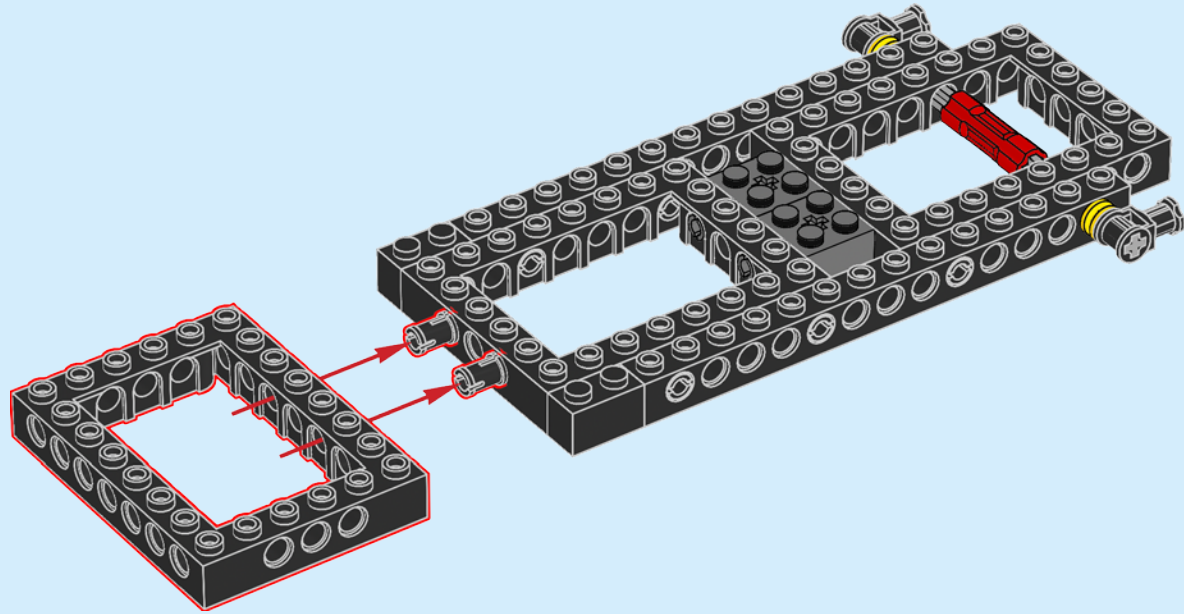

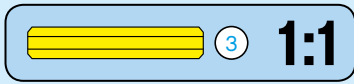
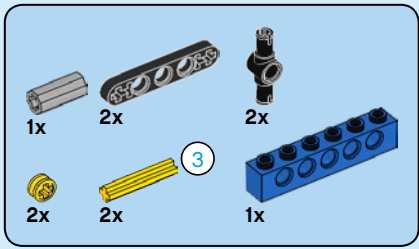

8

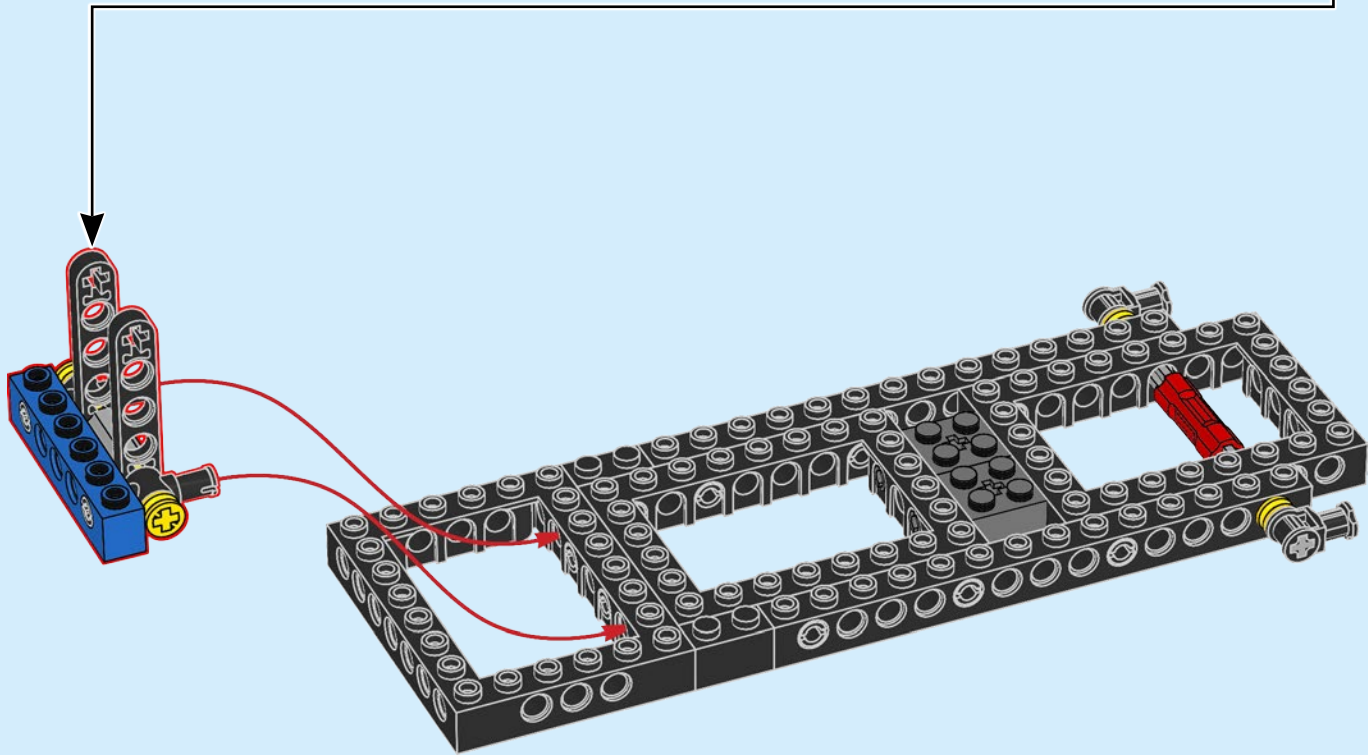
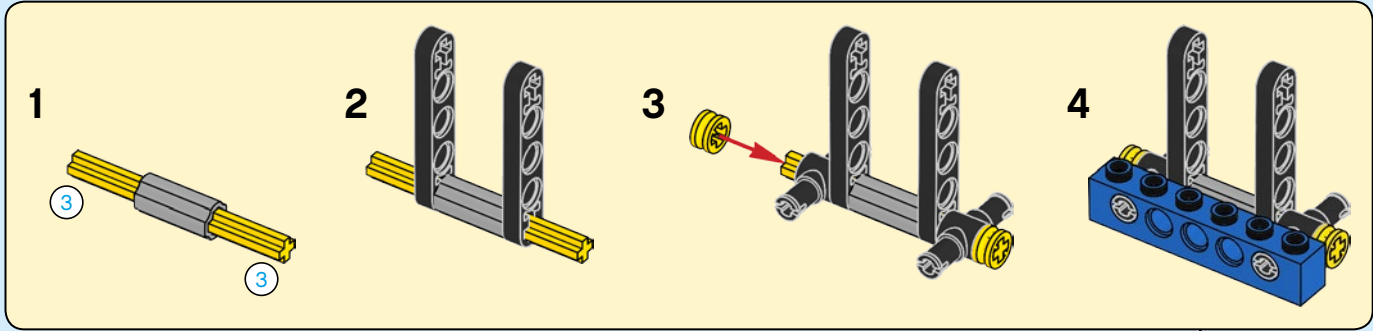

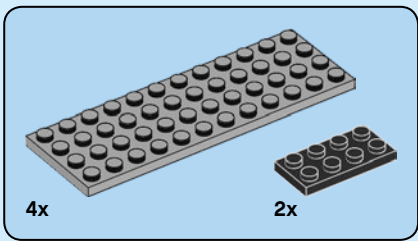

9

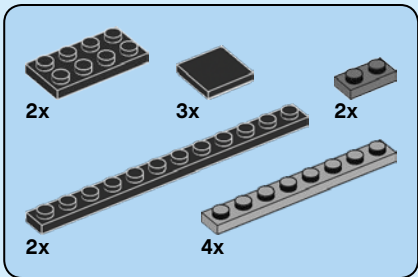
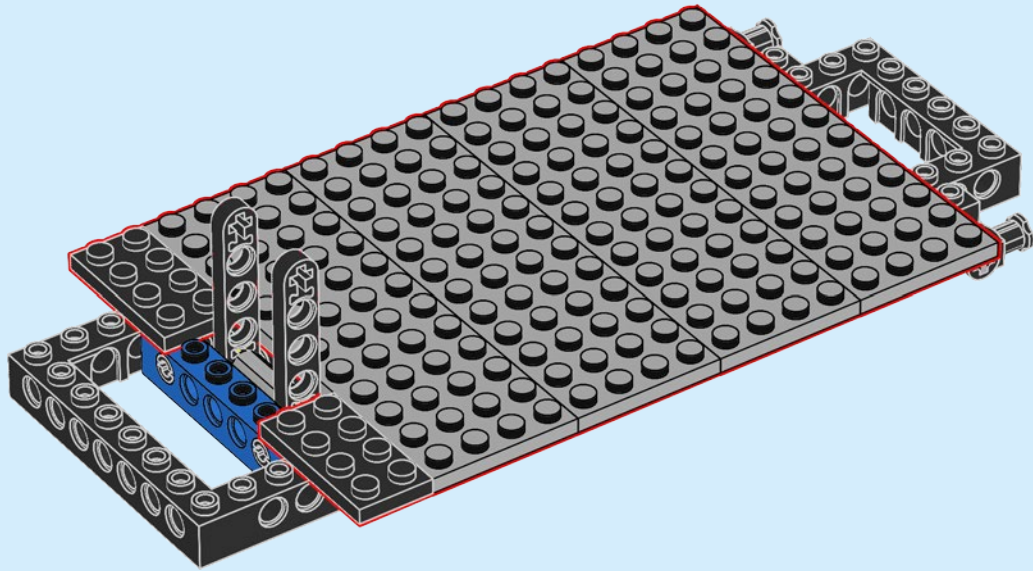

10

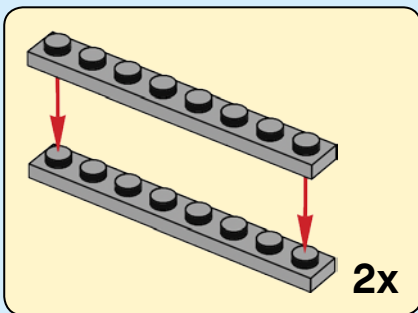
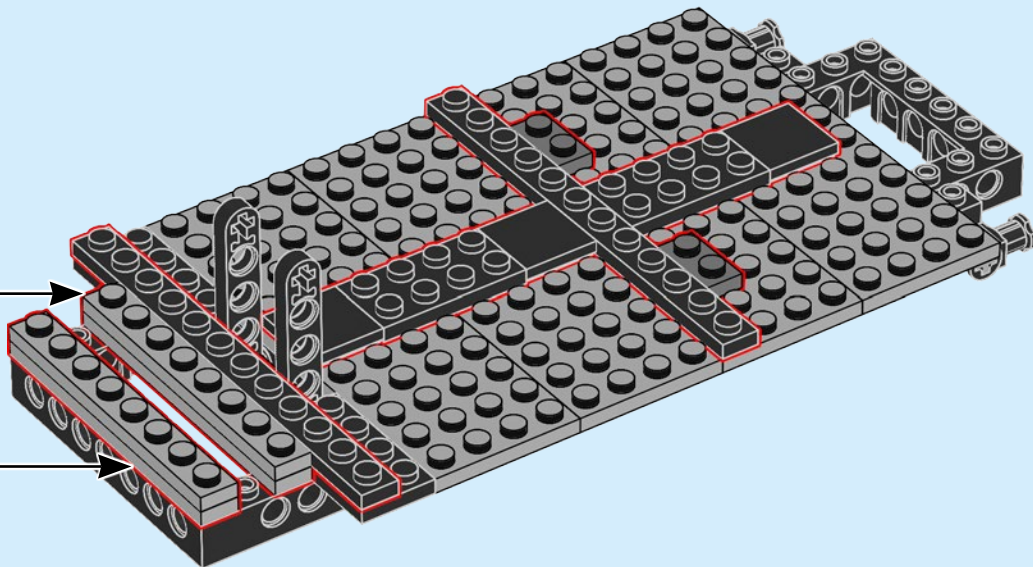

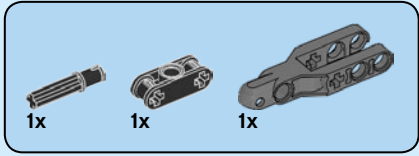
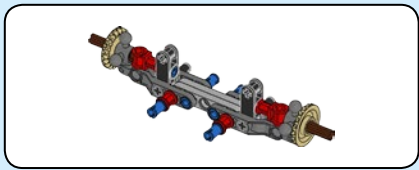

11

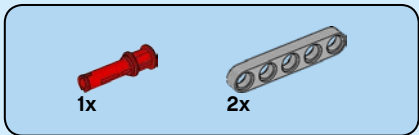
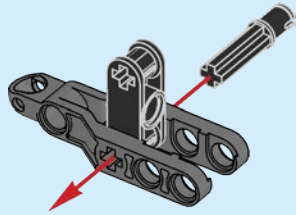

12

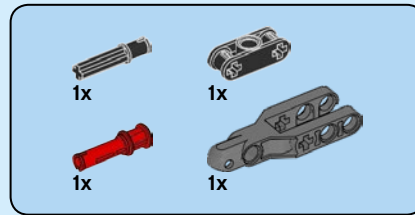
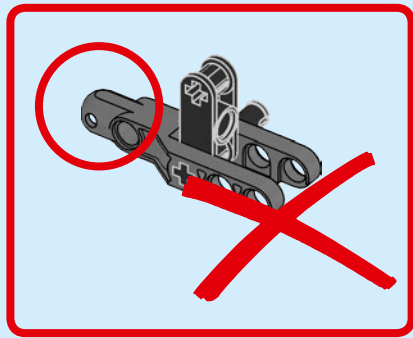
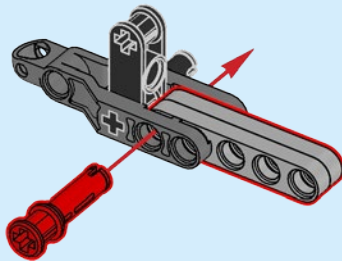

13

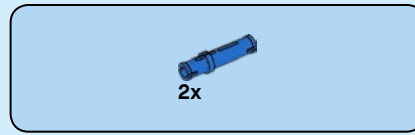
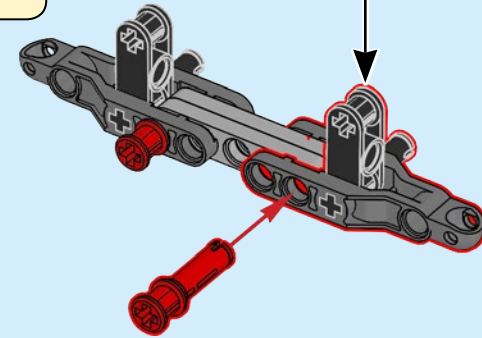
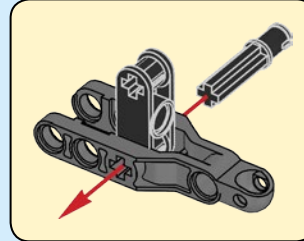

14

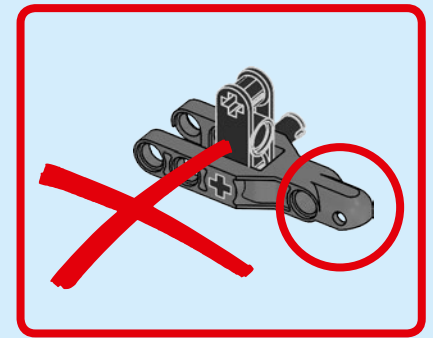
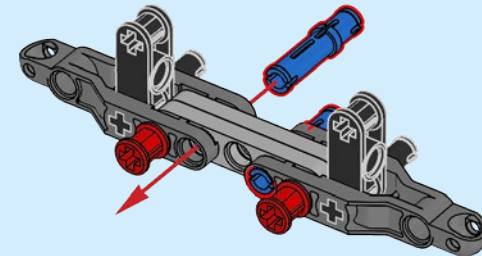



15

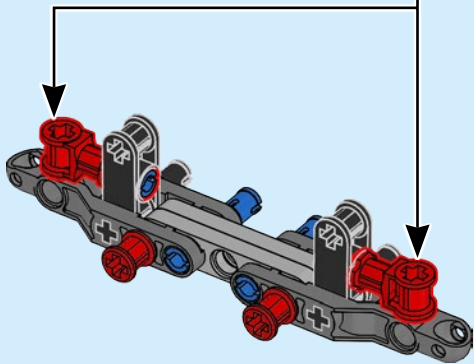
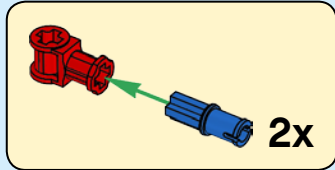

16

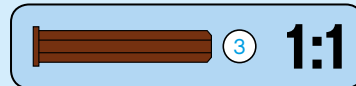
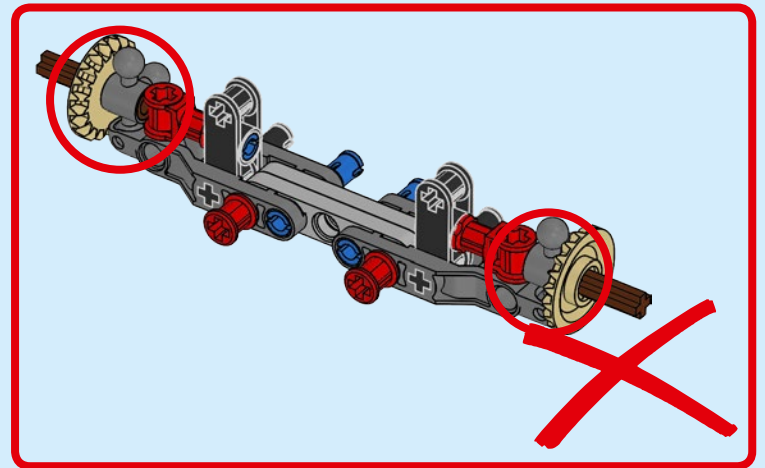
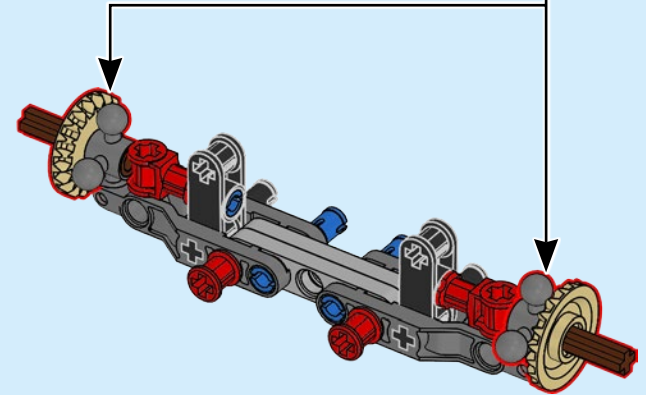
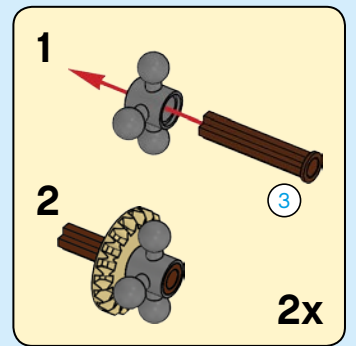



2x

17

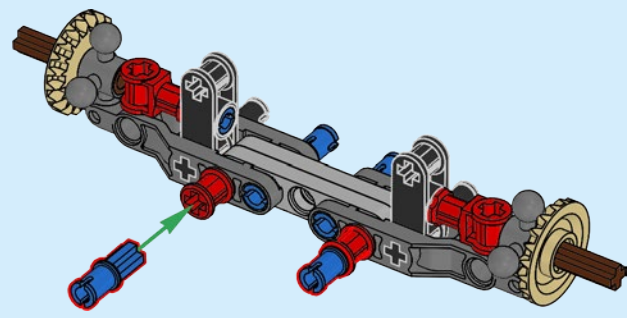

18

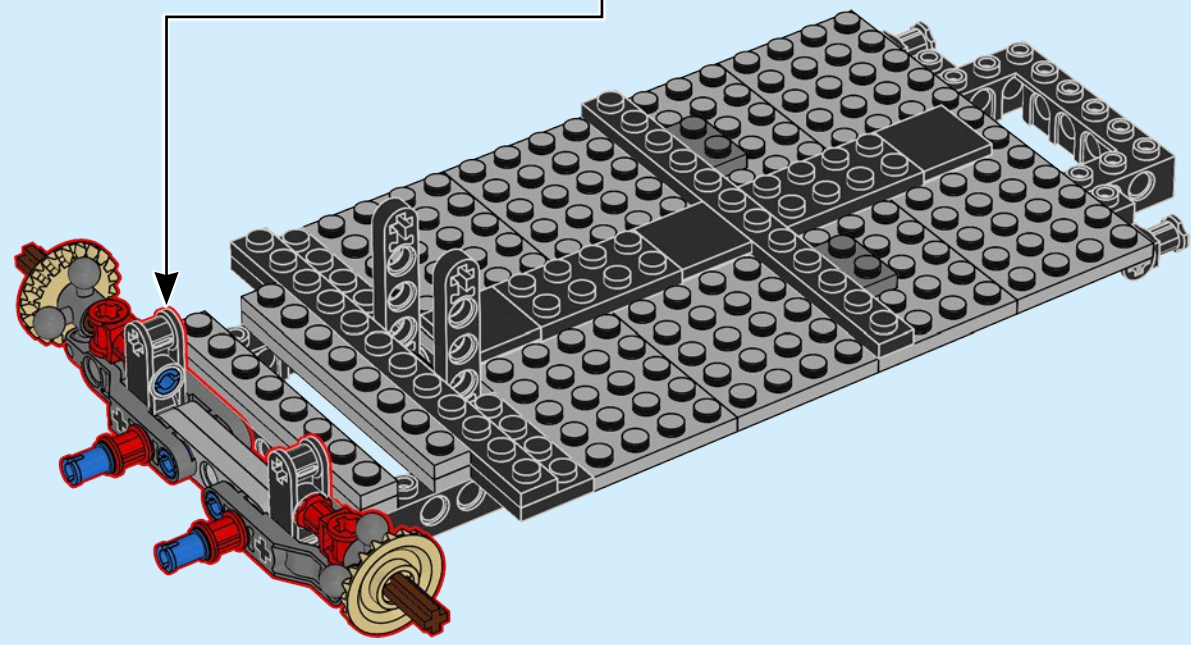

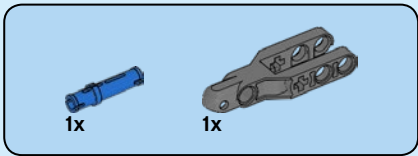
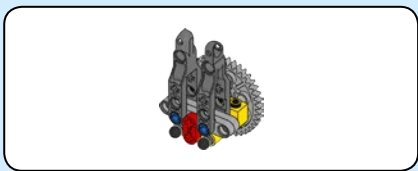

19

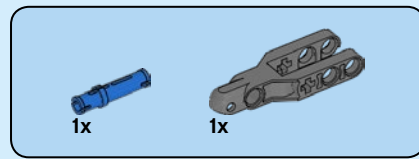
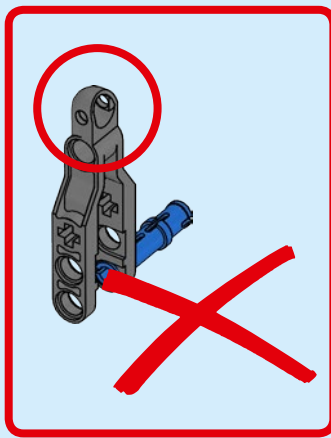

21

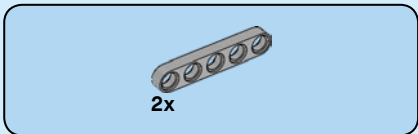
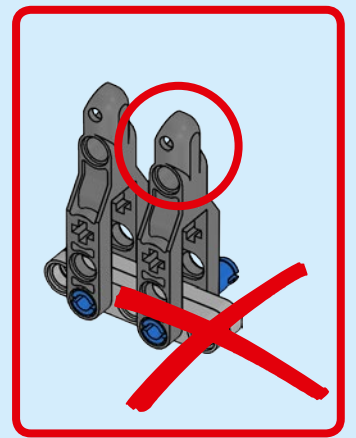

20

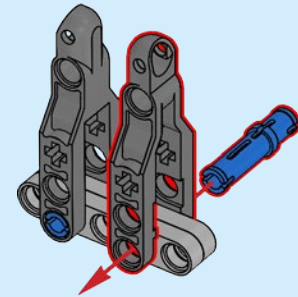
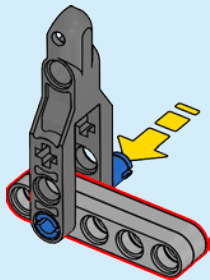

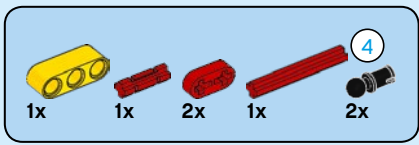

22

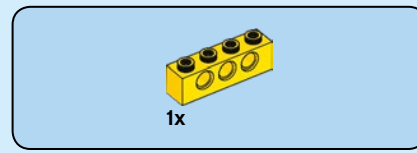
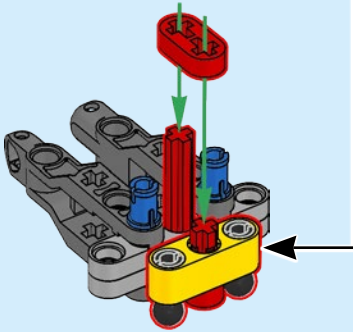
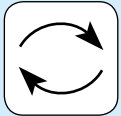
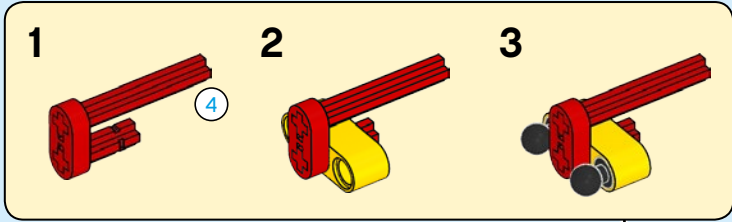

23

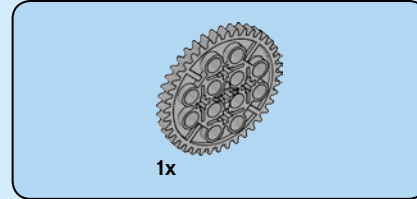
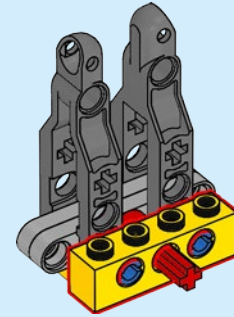
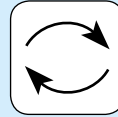

24

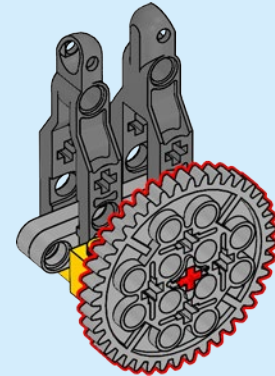

25

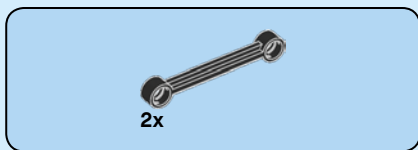
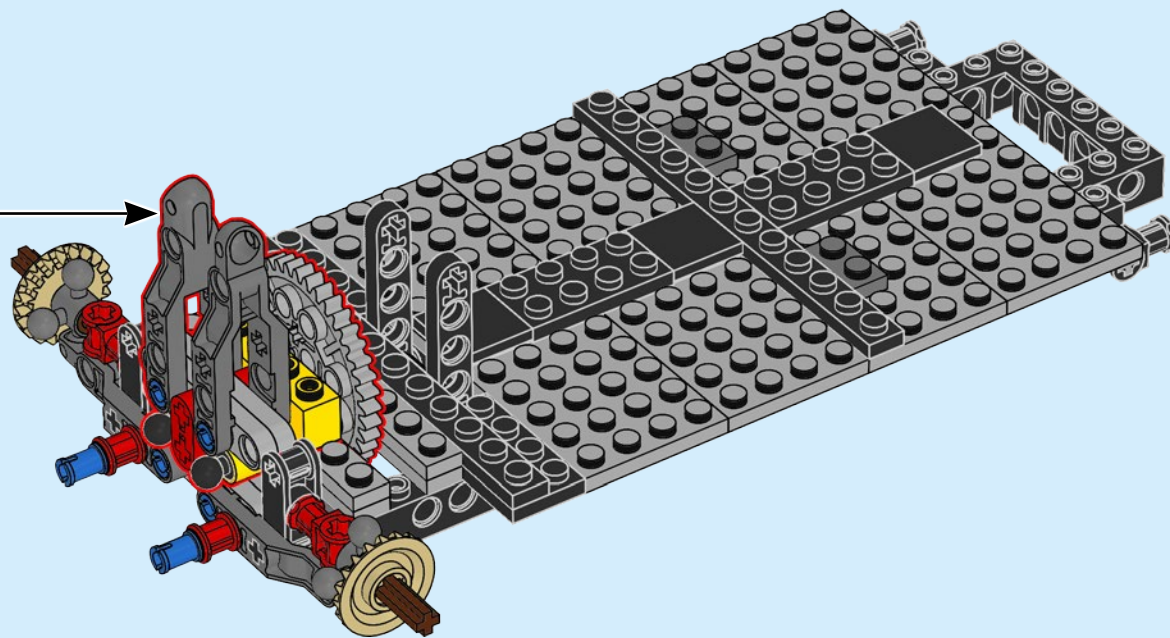

26

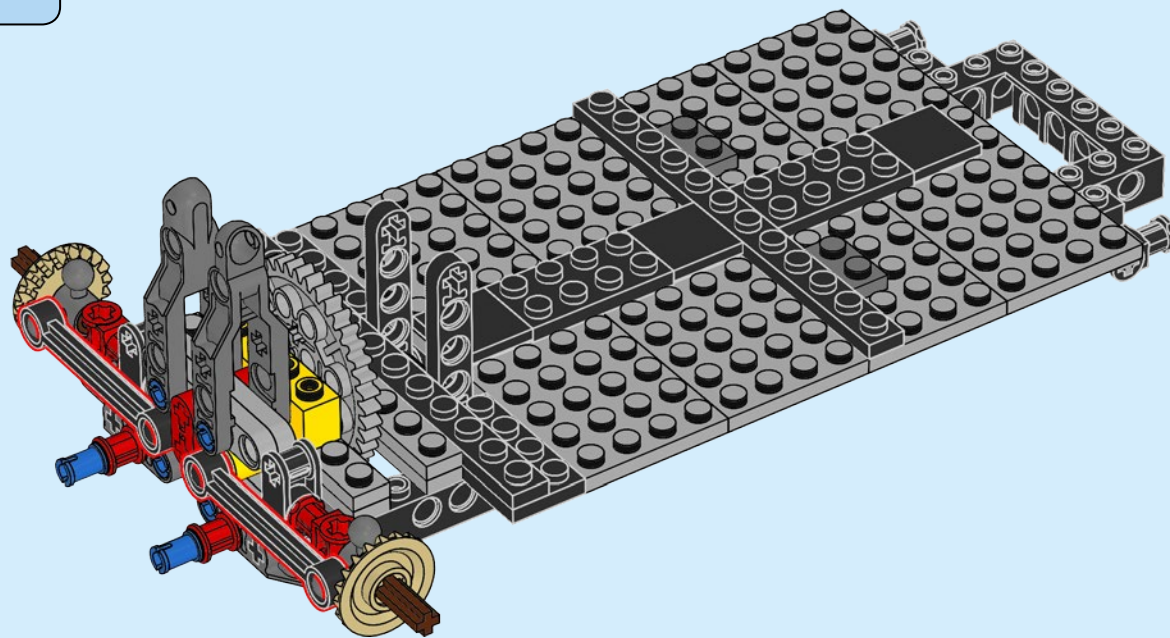



2x

27

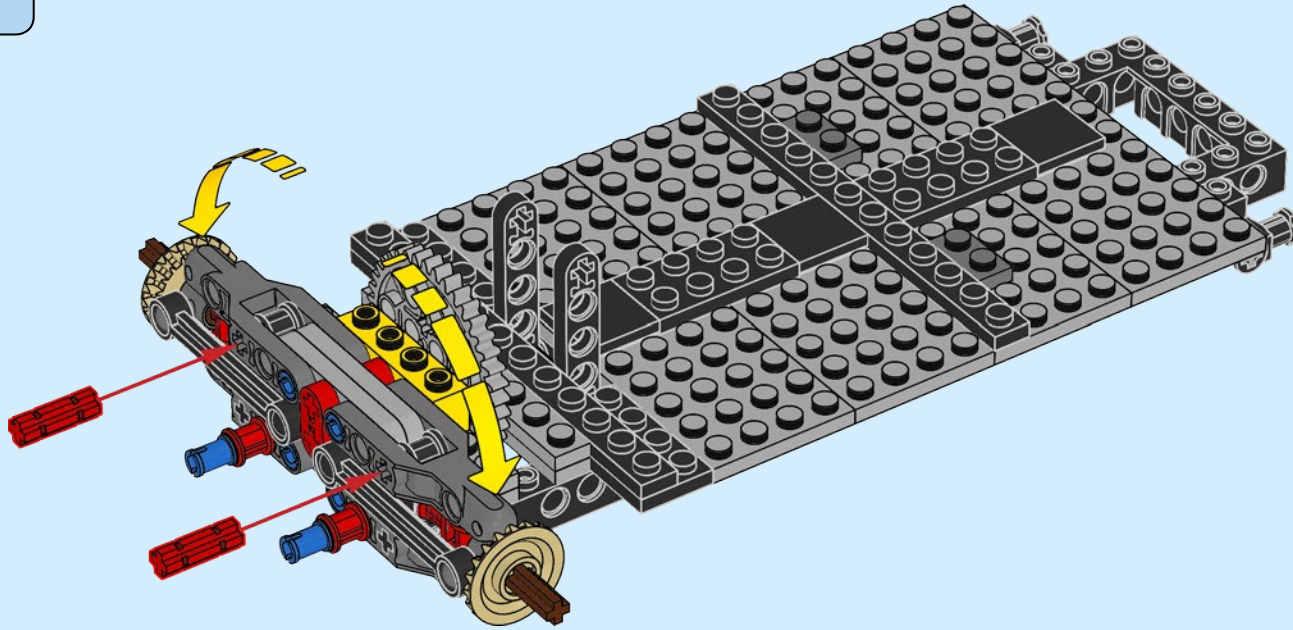

2x



2x

28

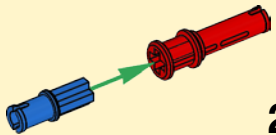
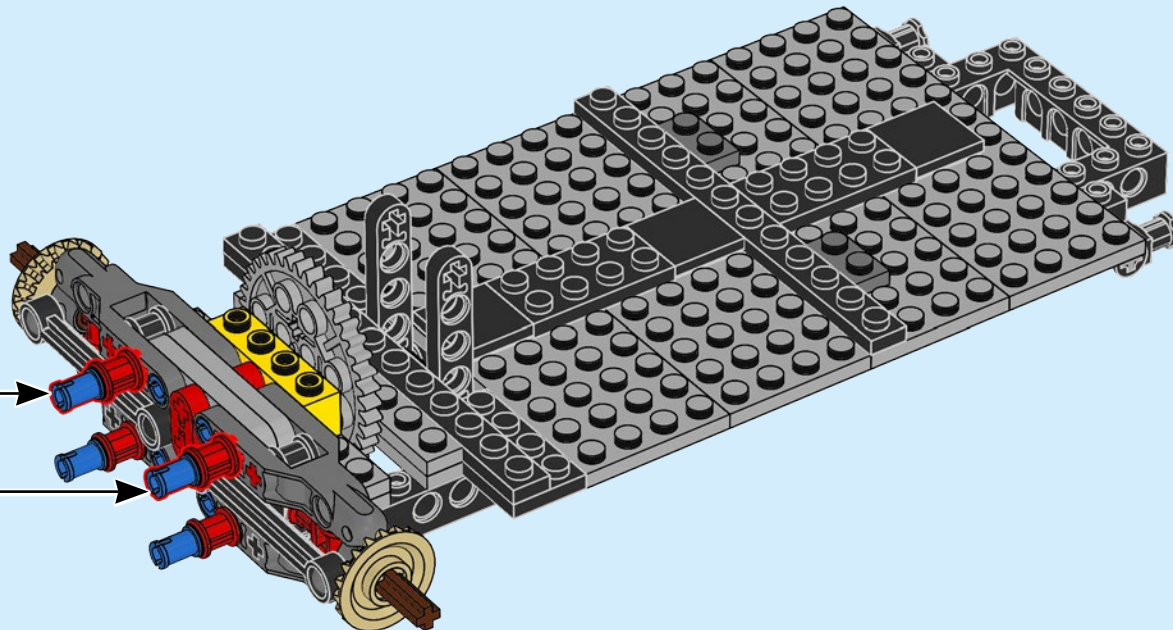

2x

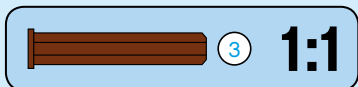
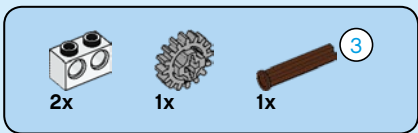

29

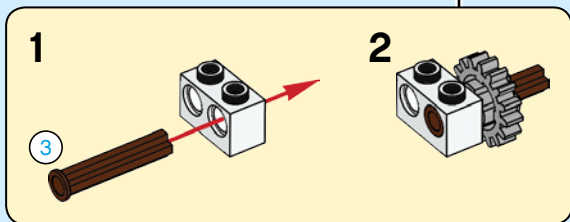
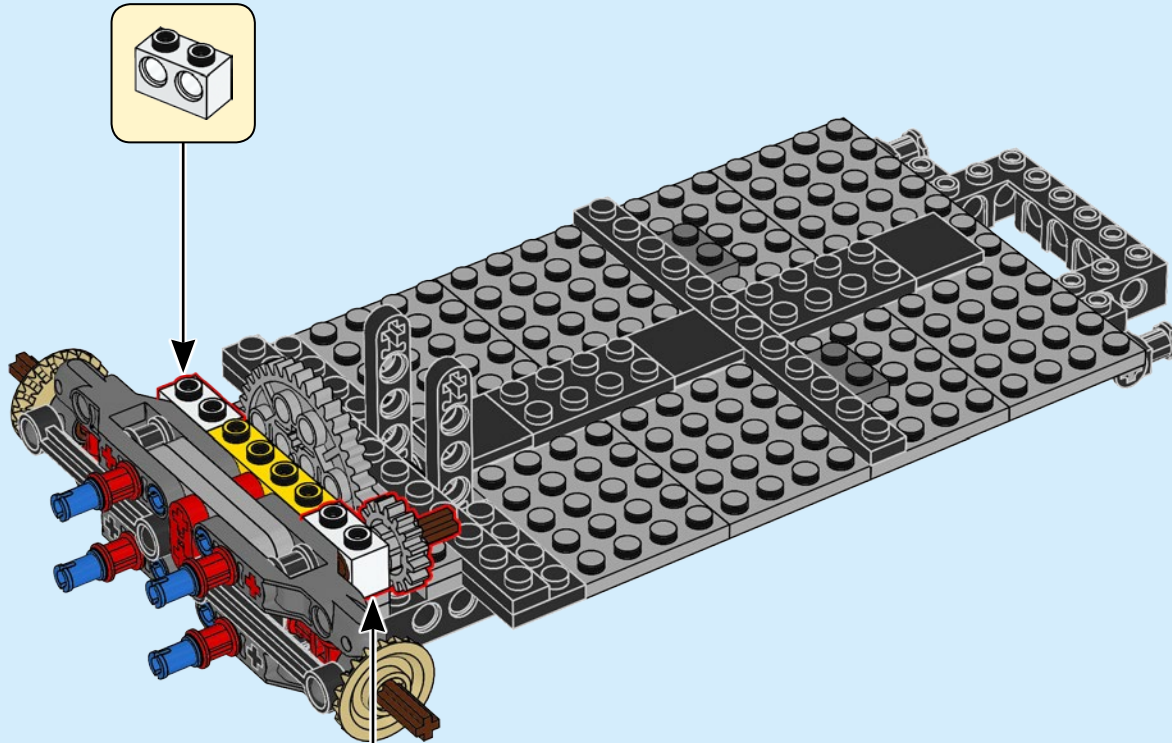

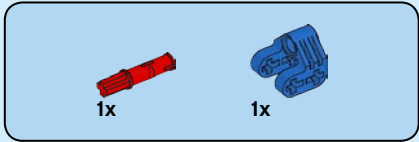
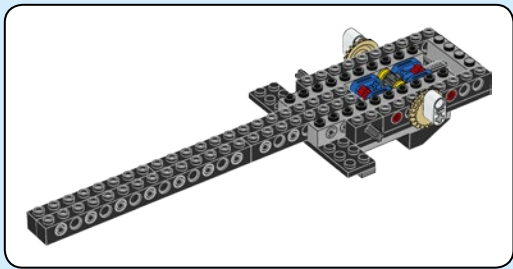

30

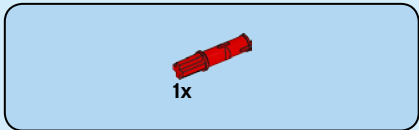
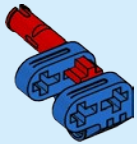

31

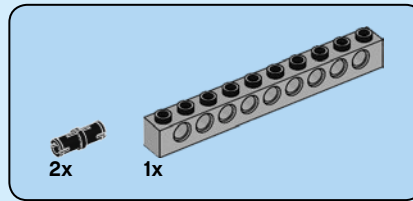
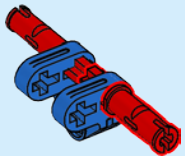

32

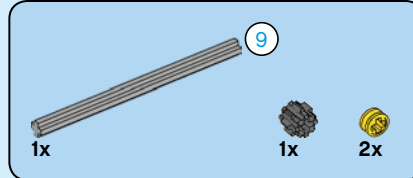
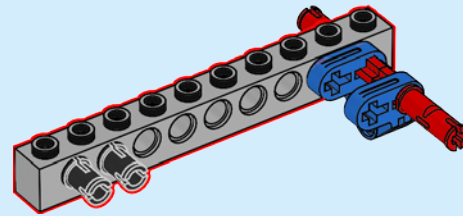

33

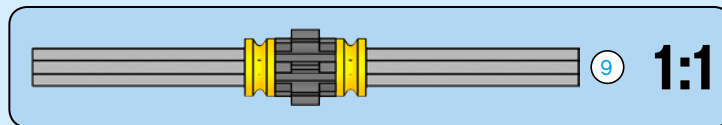
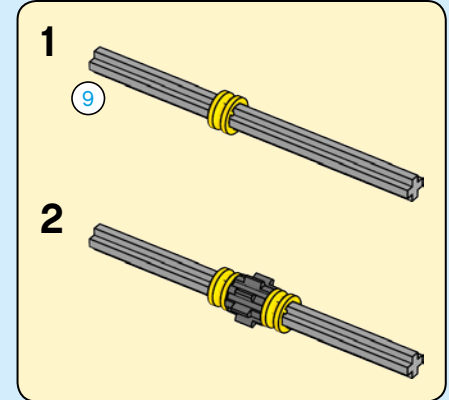
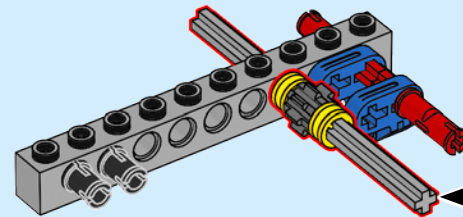

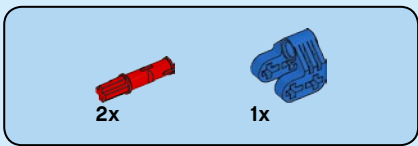

34

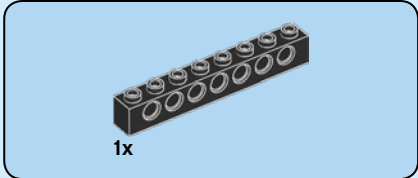
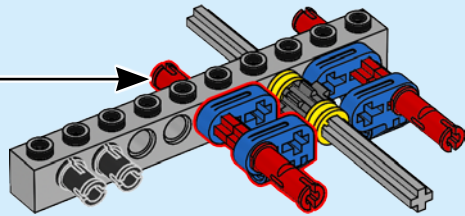
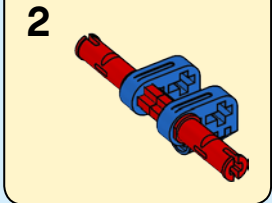
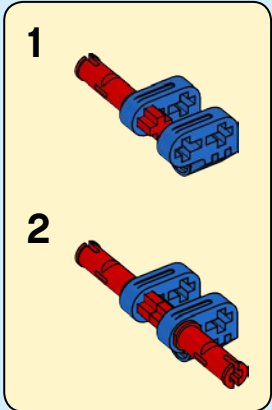

35

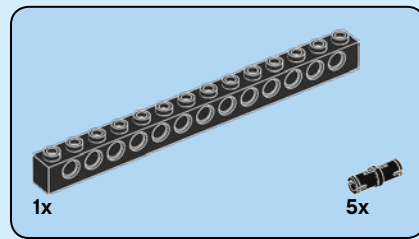
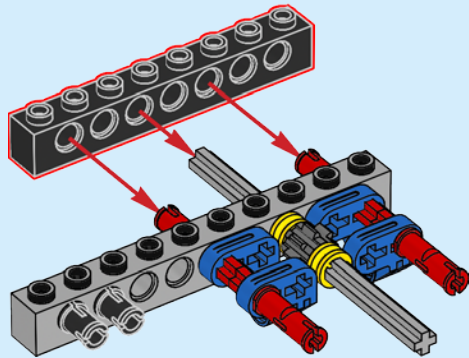

36

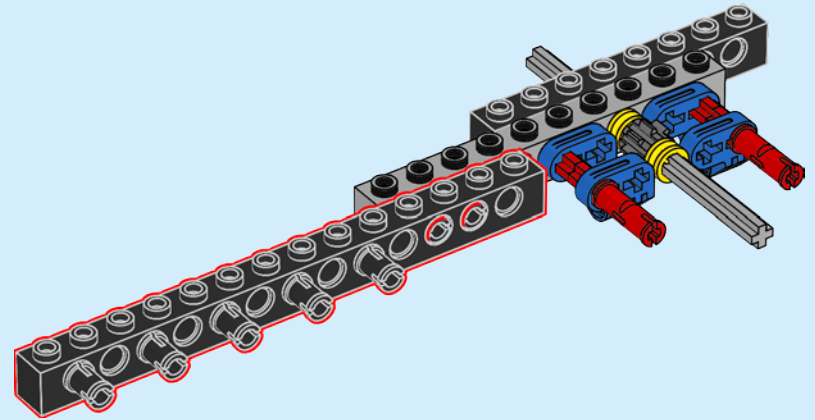

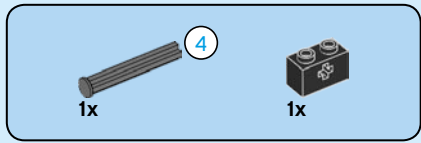

37

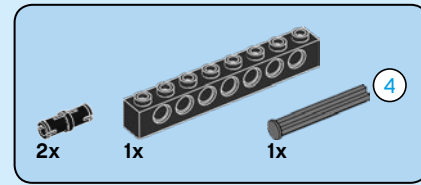
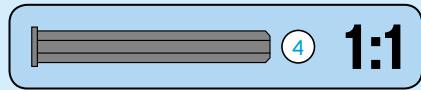
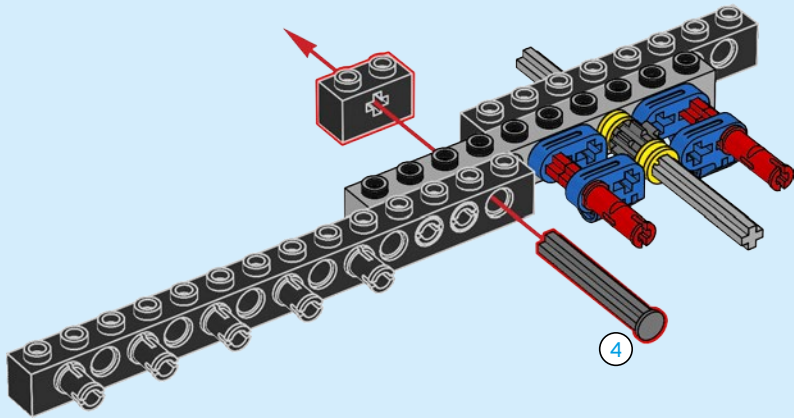

38

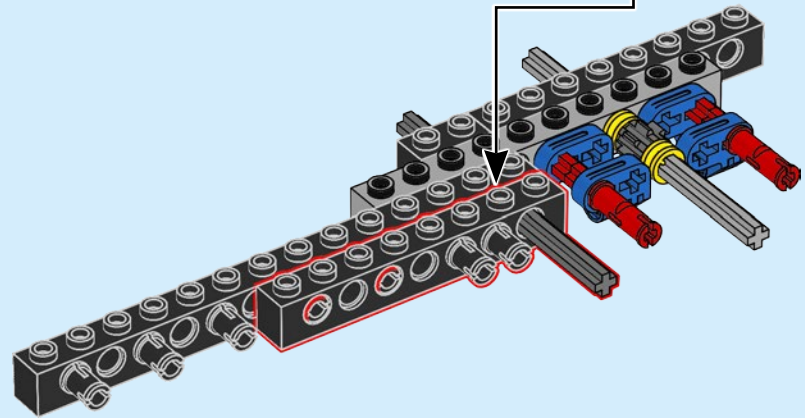
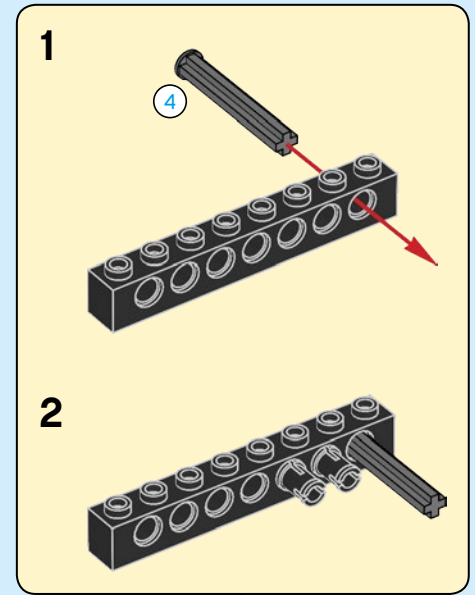

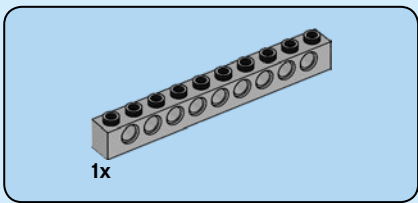

39

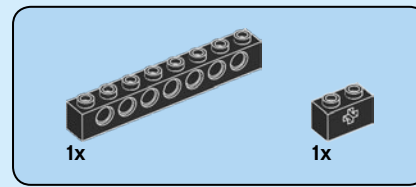
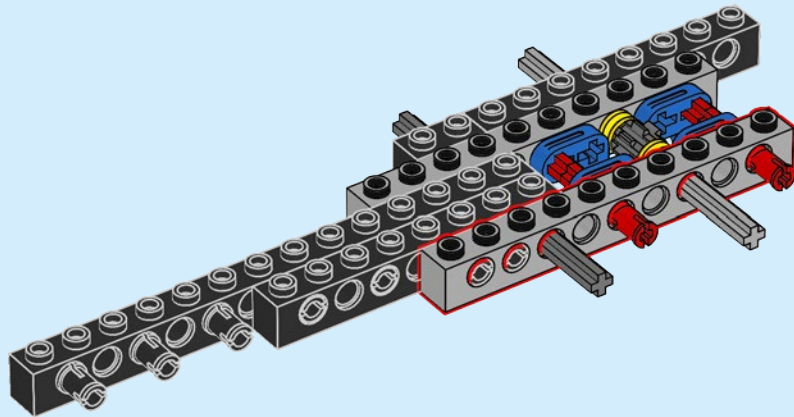

40

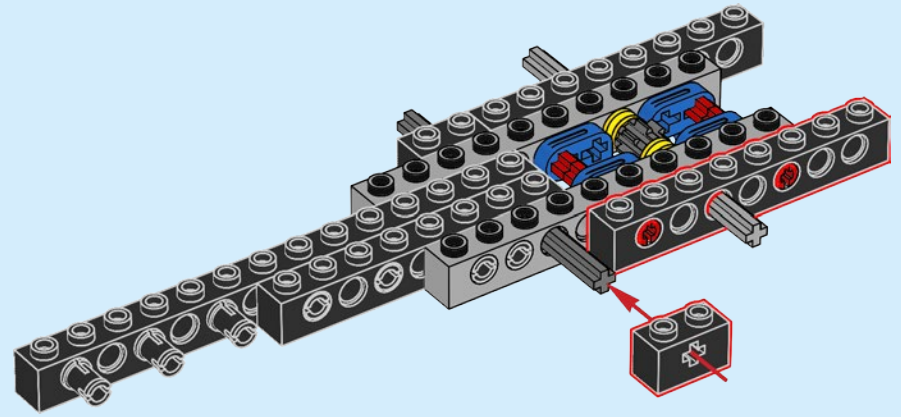

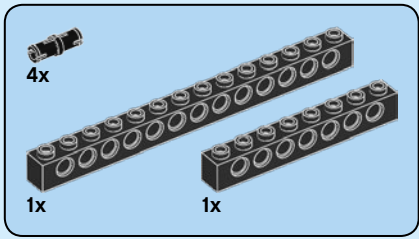

41



The Mustang is the car driven by Steve McQueen in the iconic car chase in the 1968 movie *Bullitt*.

La Mustang est la voiture conduite par Steve McQueen dans la poursuite emblématique du film *Bullitt* de 1968.

Un Mustang es el auto que conduce Steve McQueen en la famosa persecución de la película *Bullitt*, de 1968.

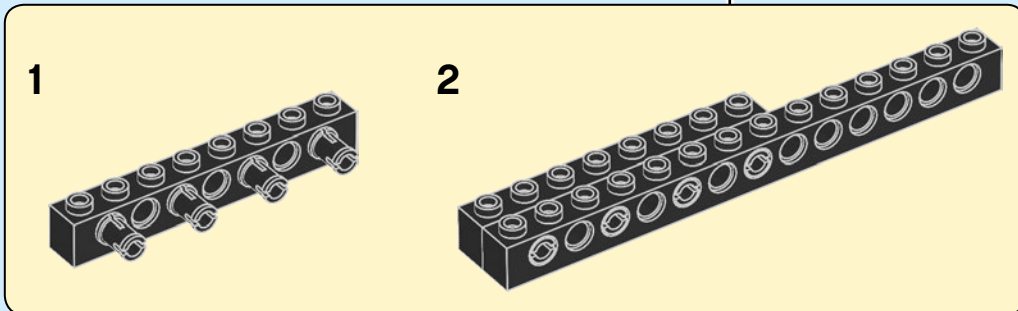
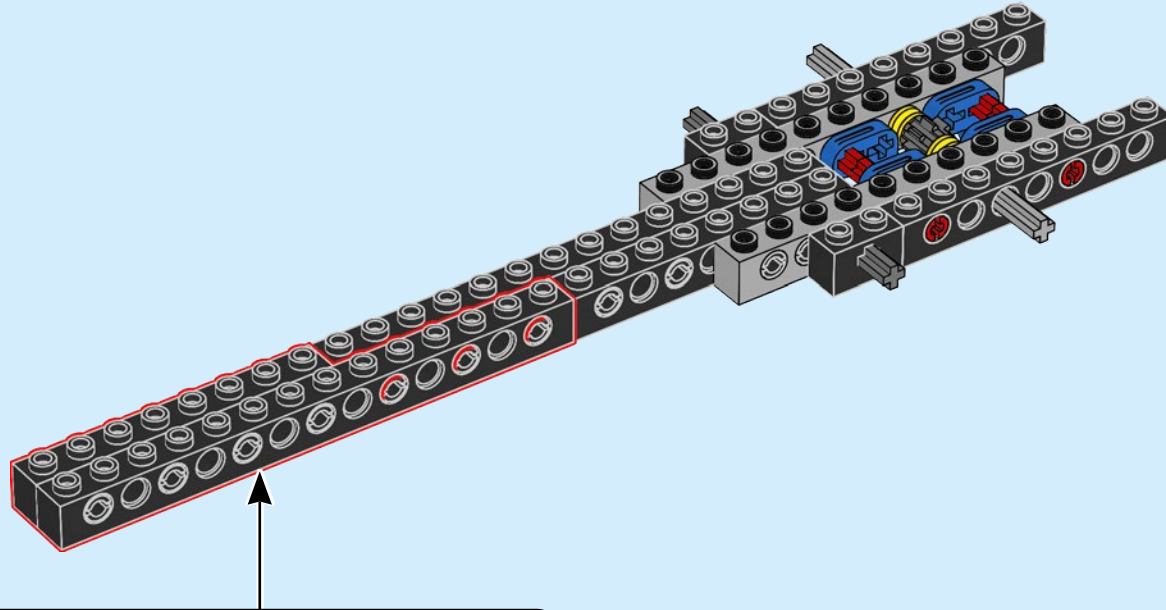

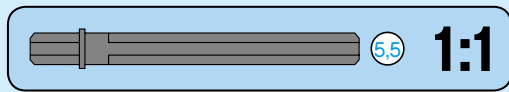
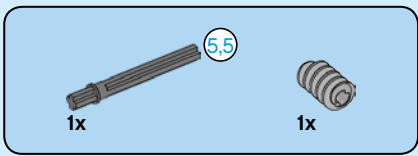

42

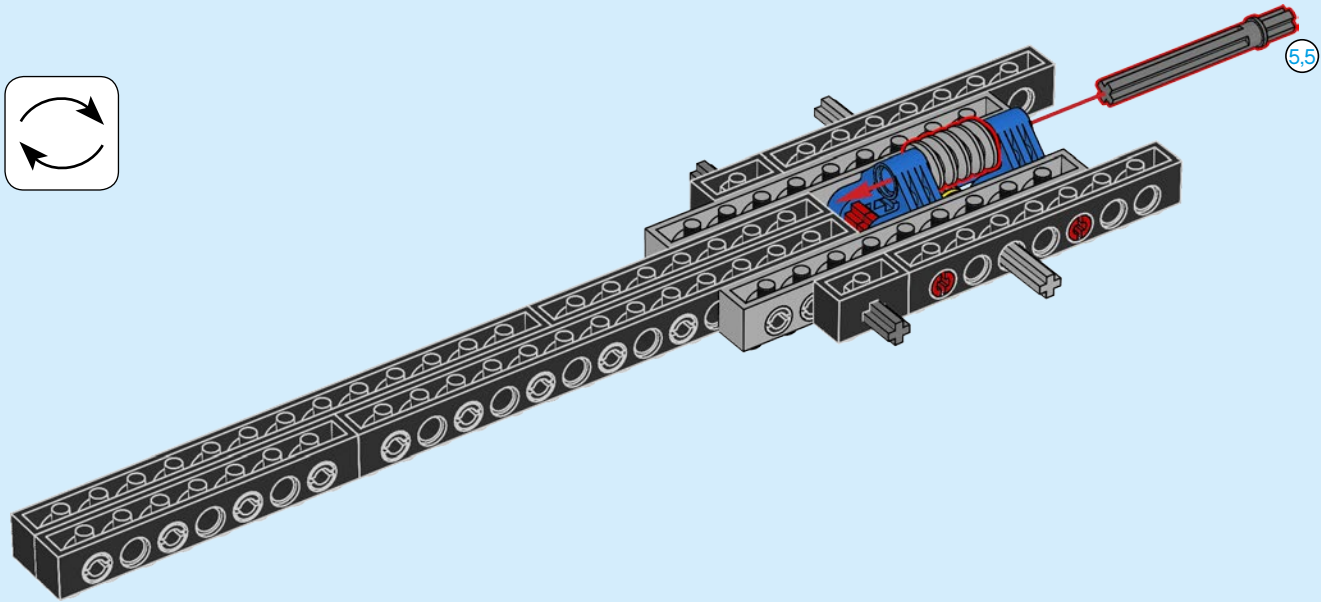
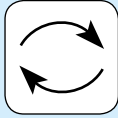

43

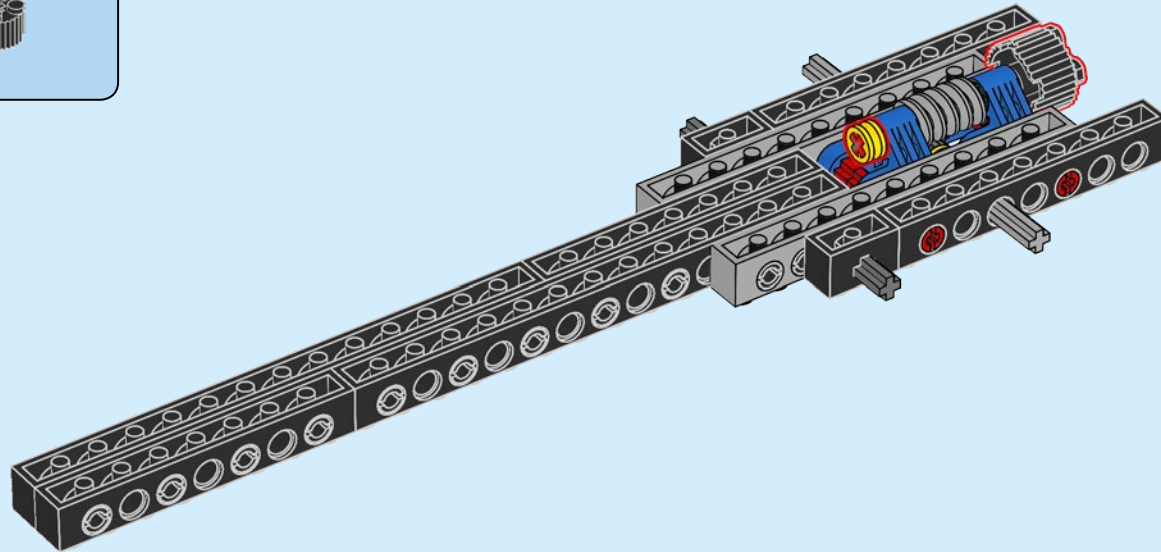

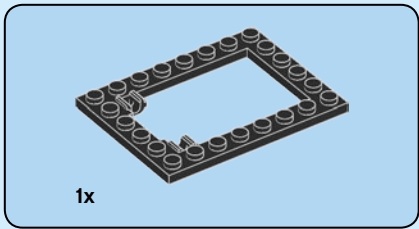

44

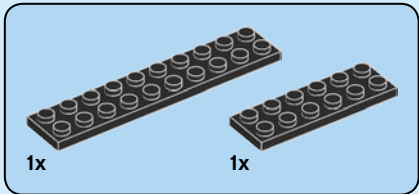
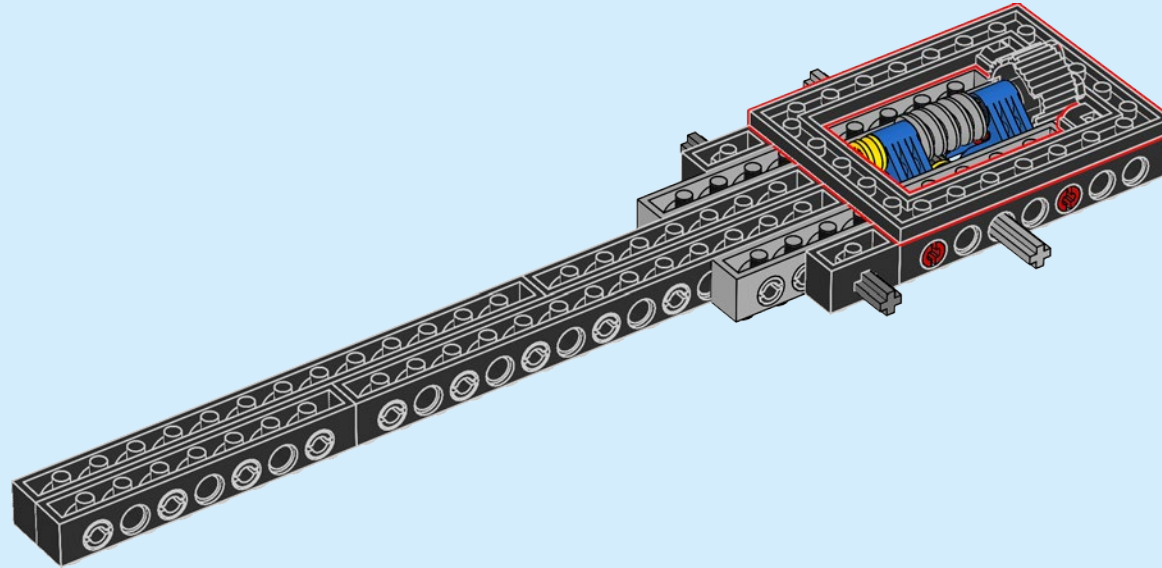

45

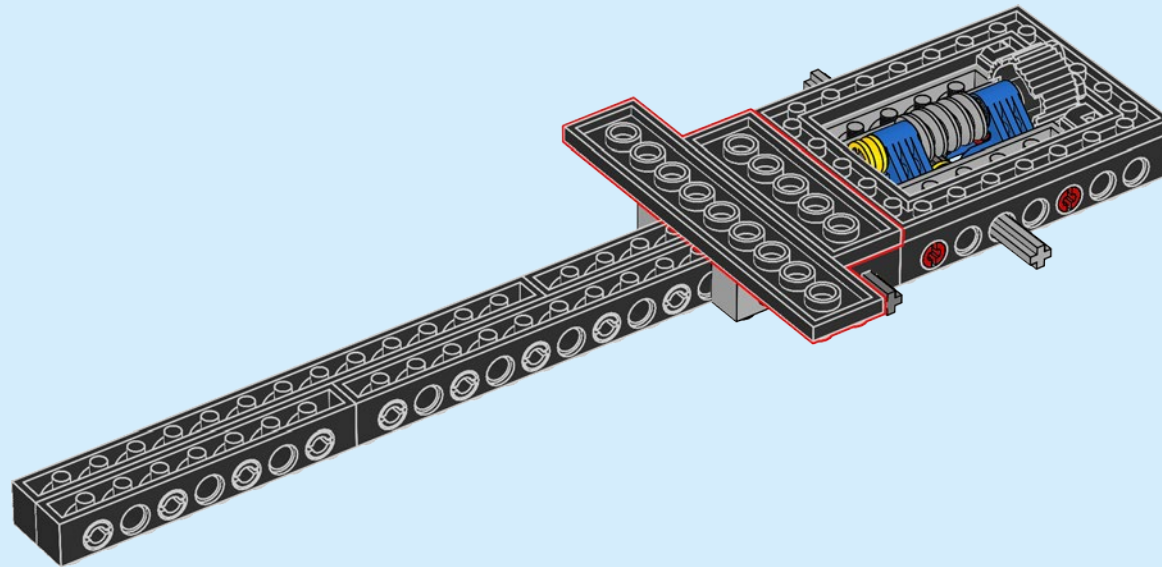

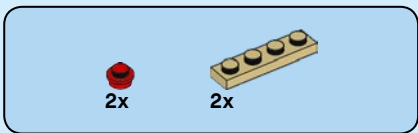

46

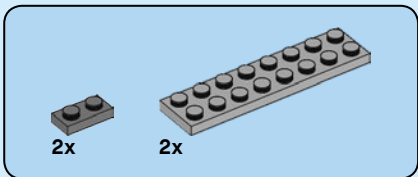
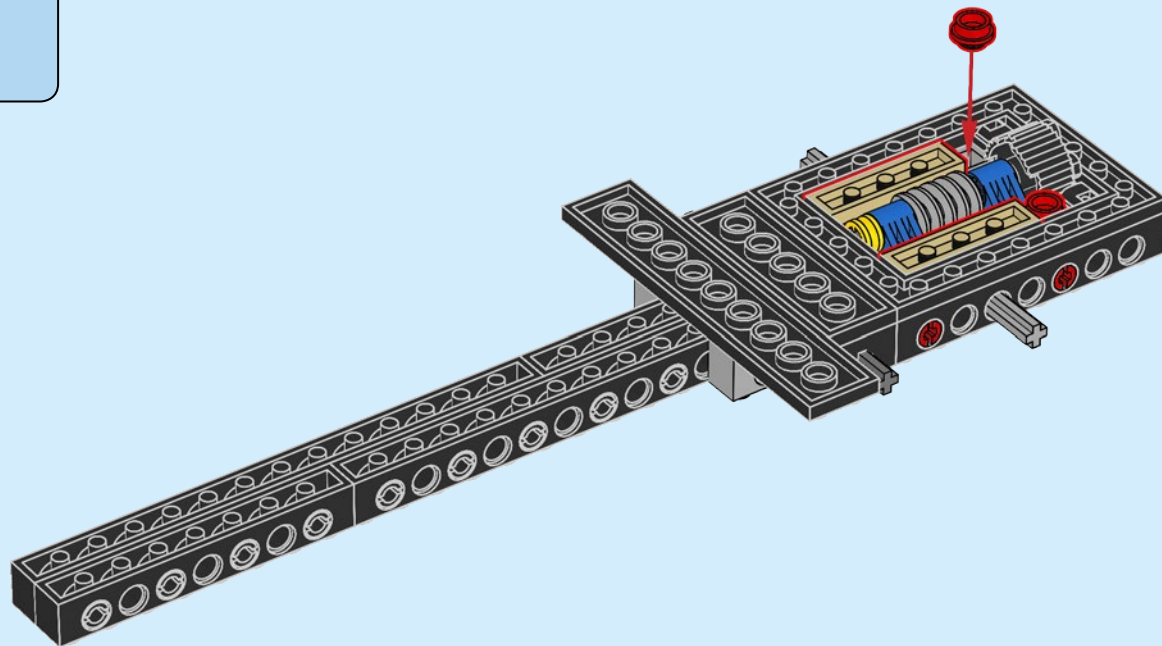

47

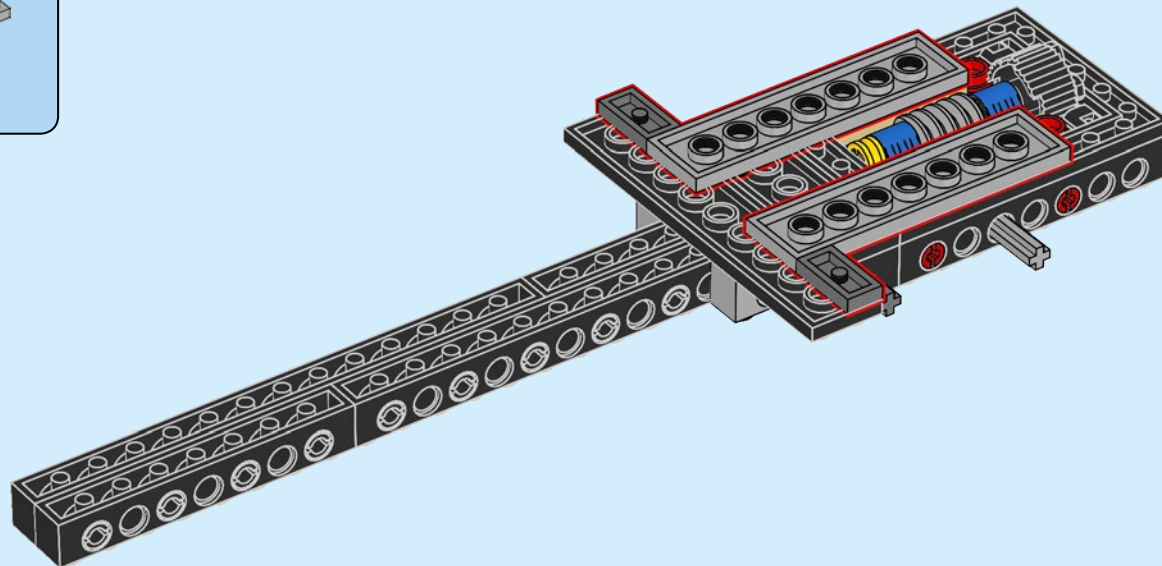

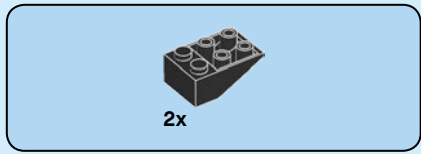

48

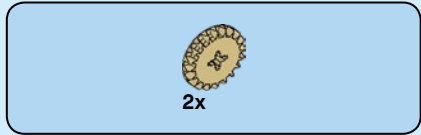
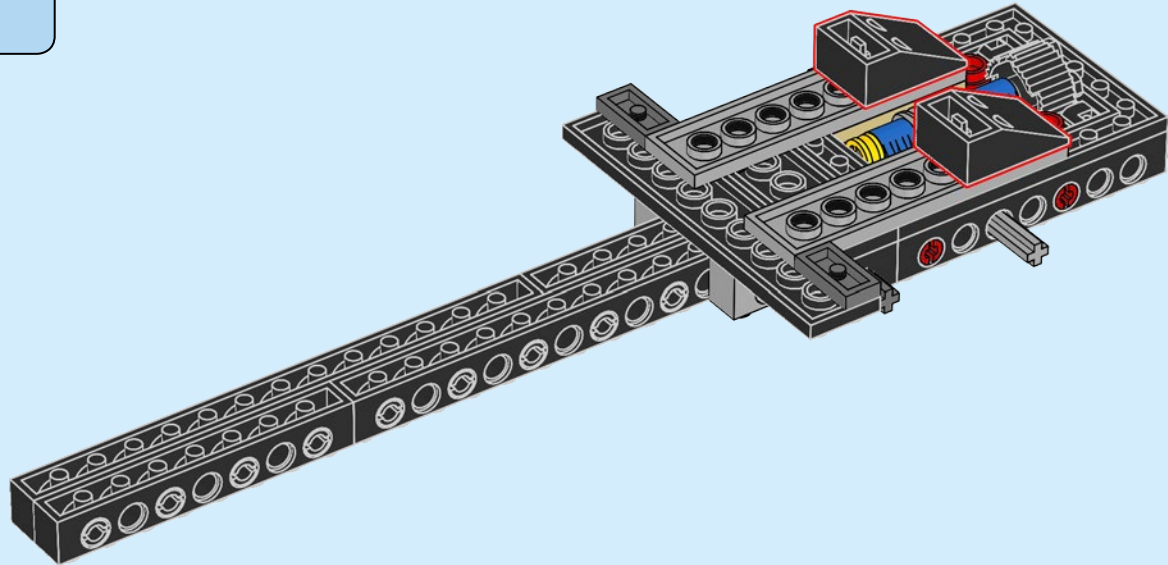

49

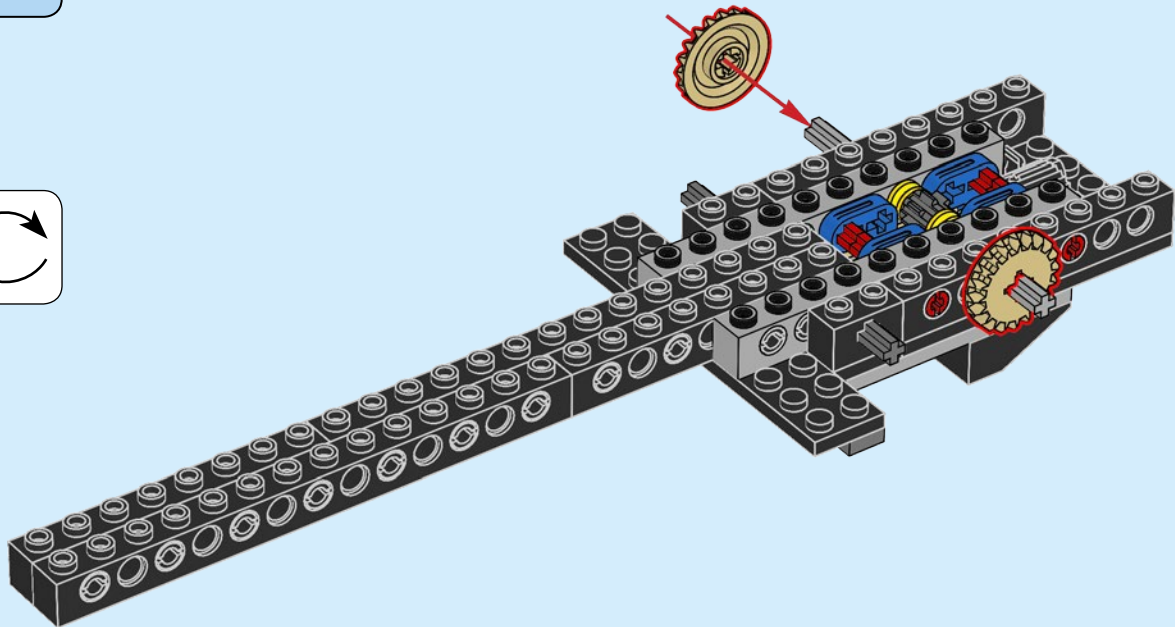
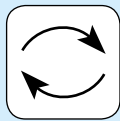

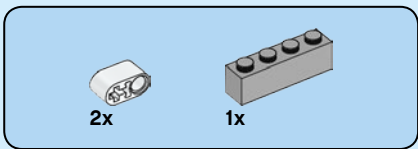

50

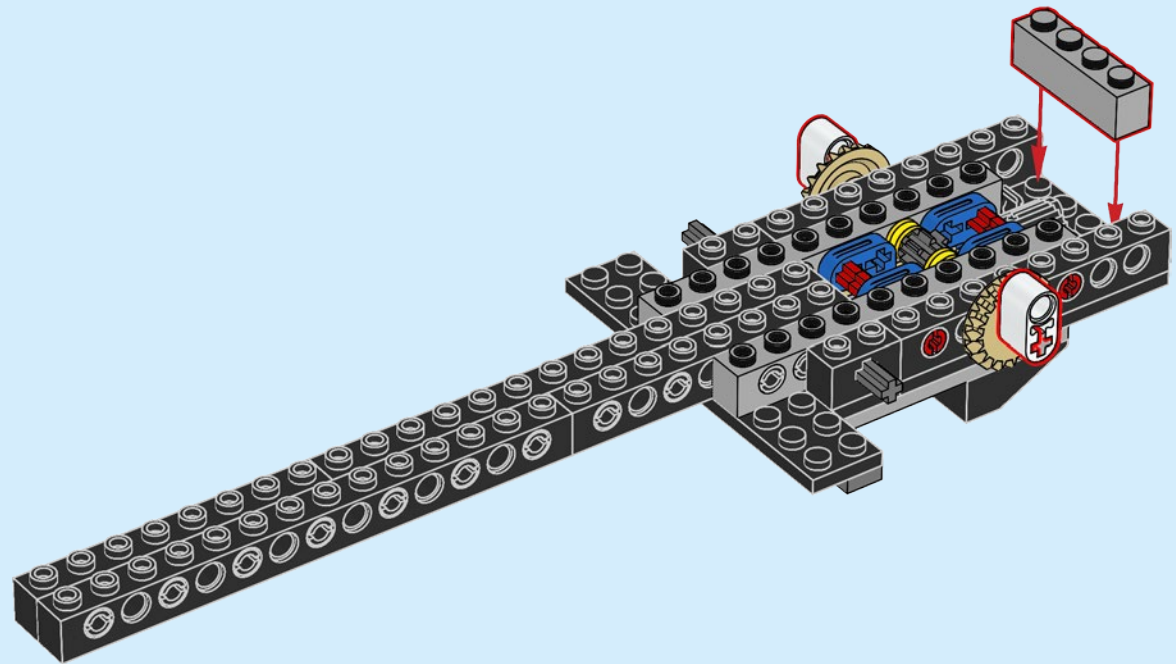

51

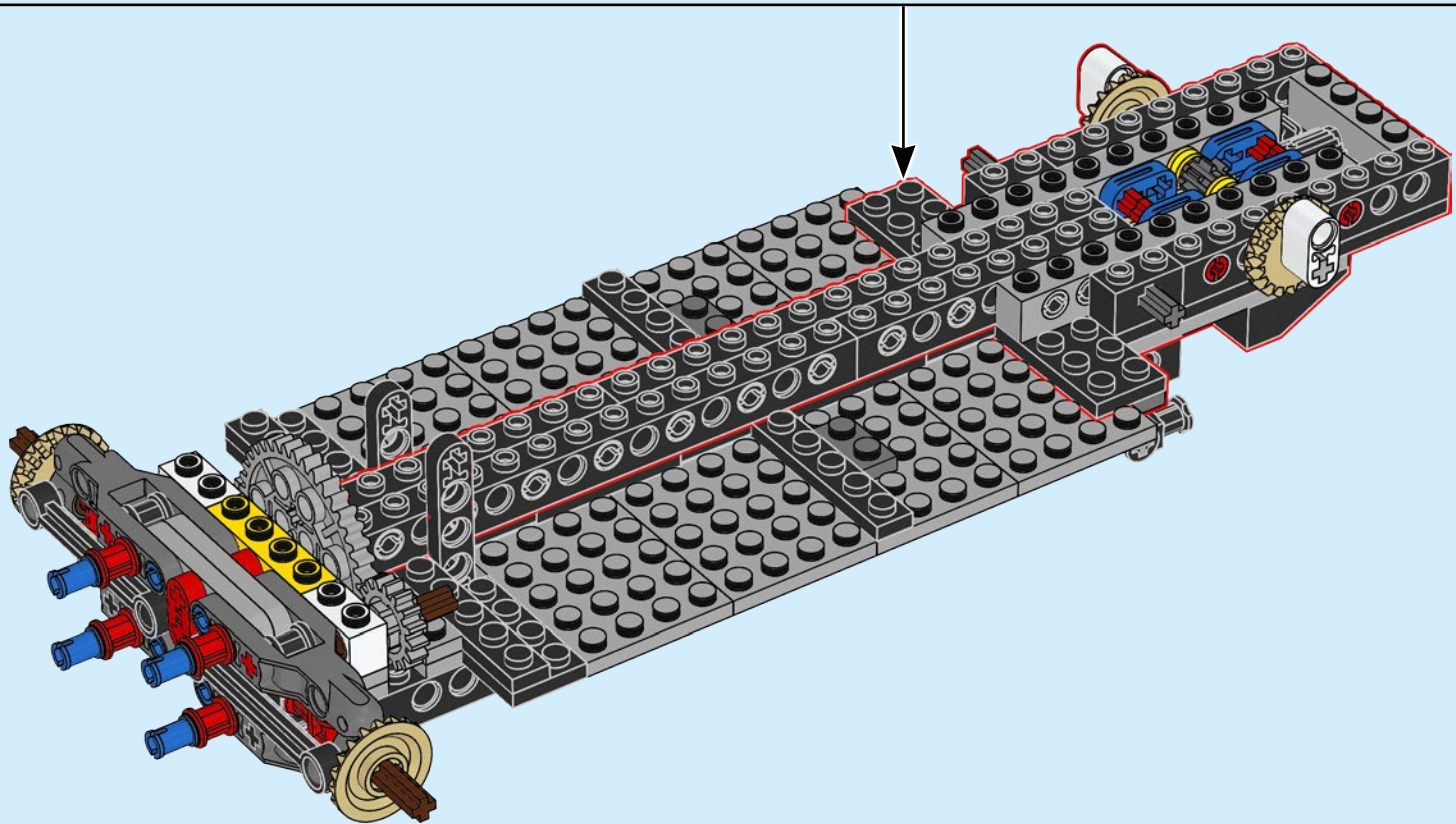

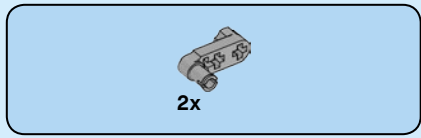

52

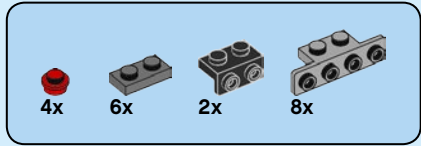
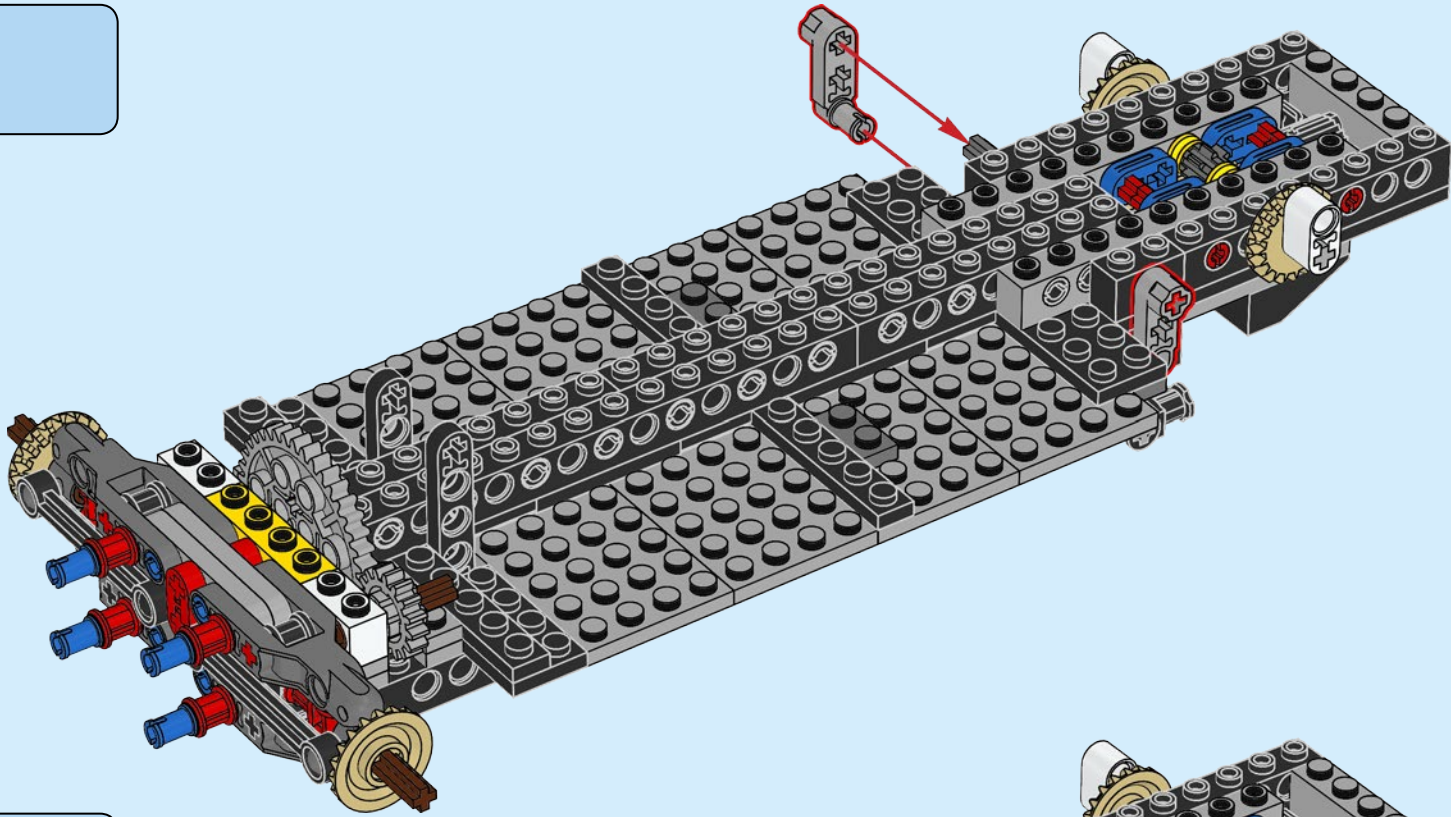

53

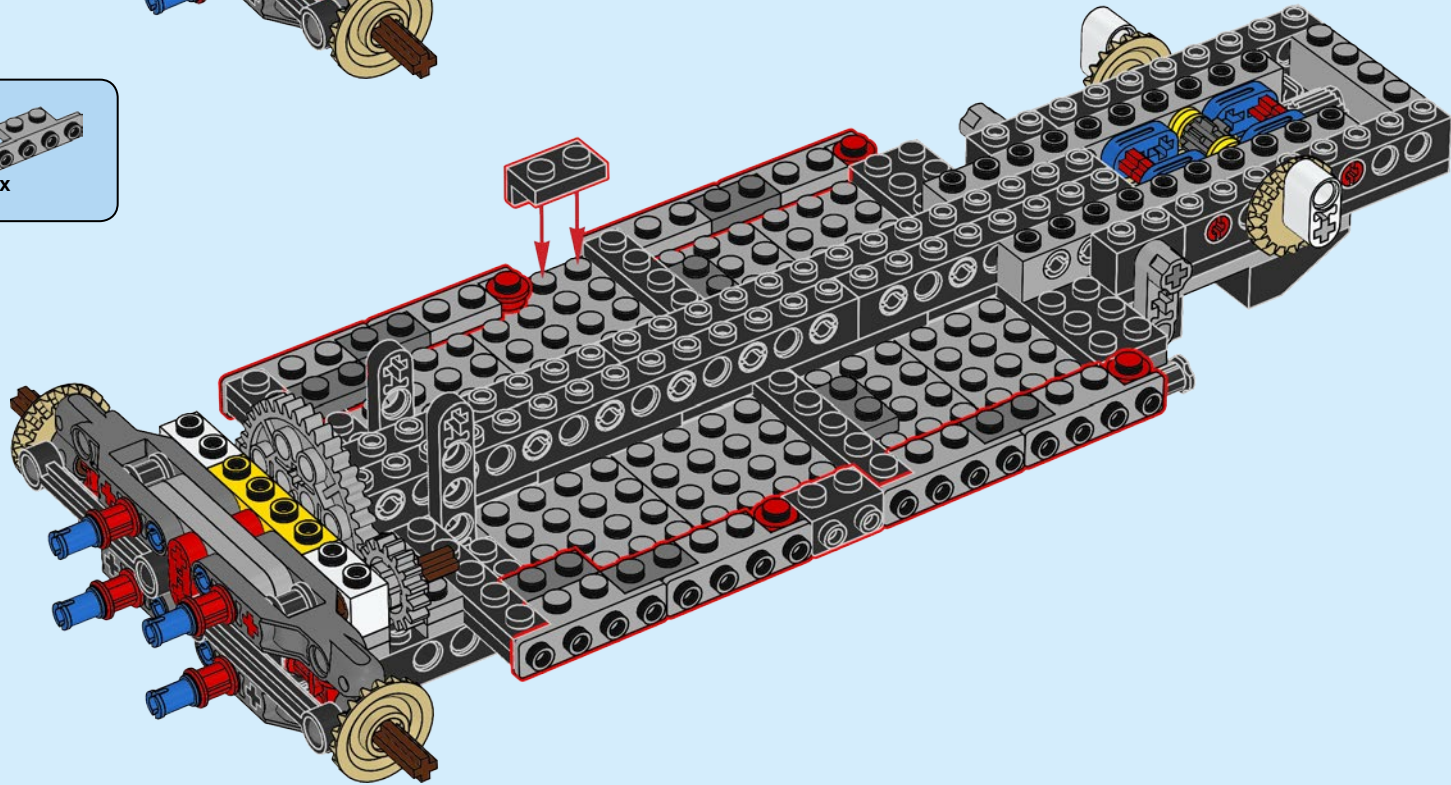

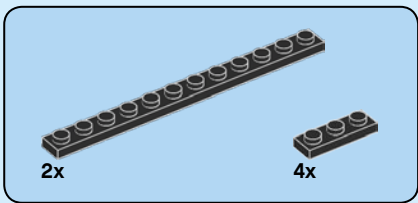

54

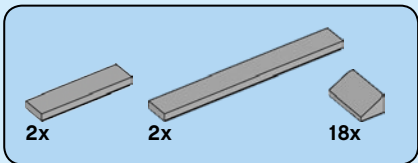
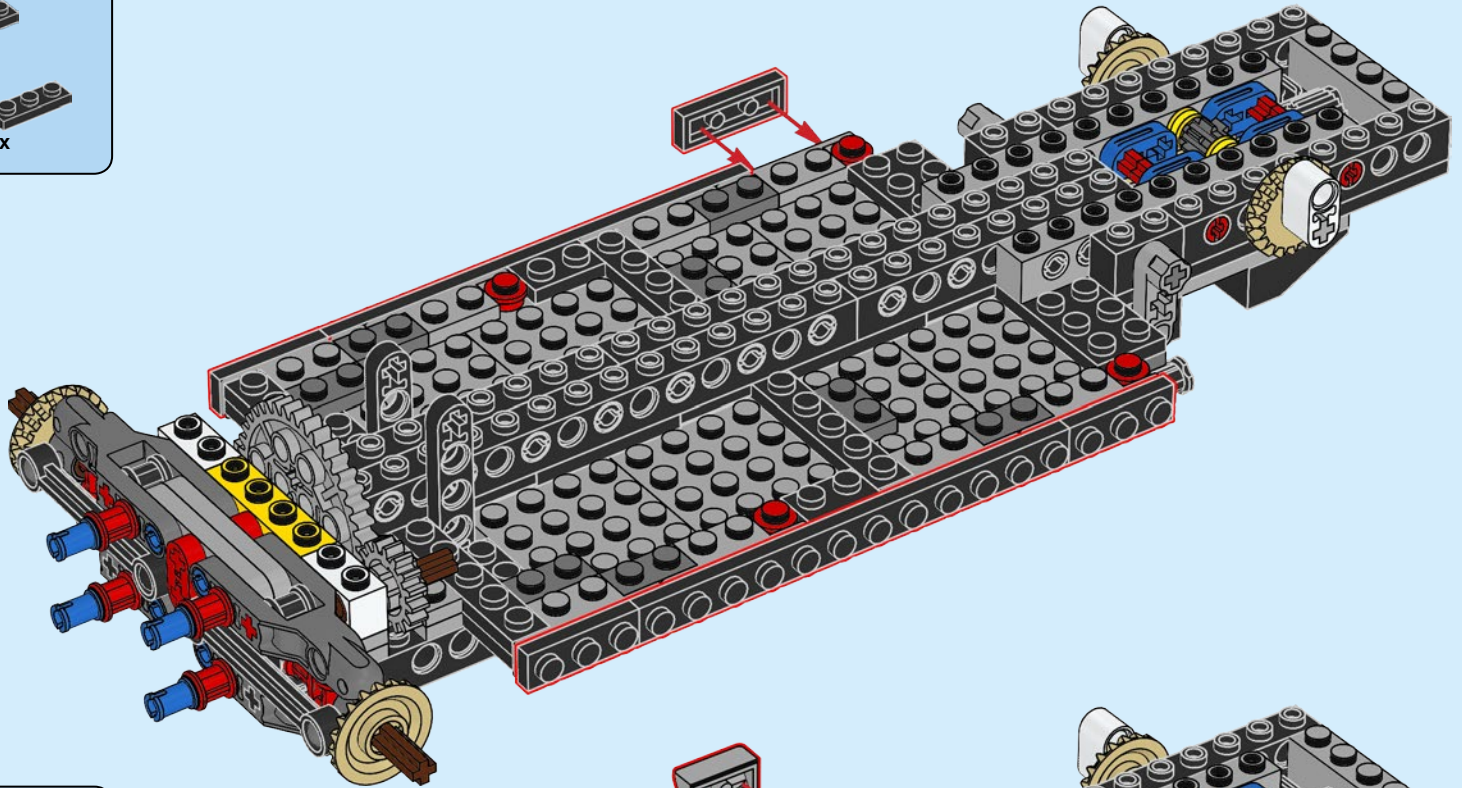

55

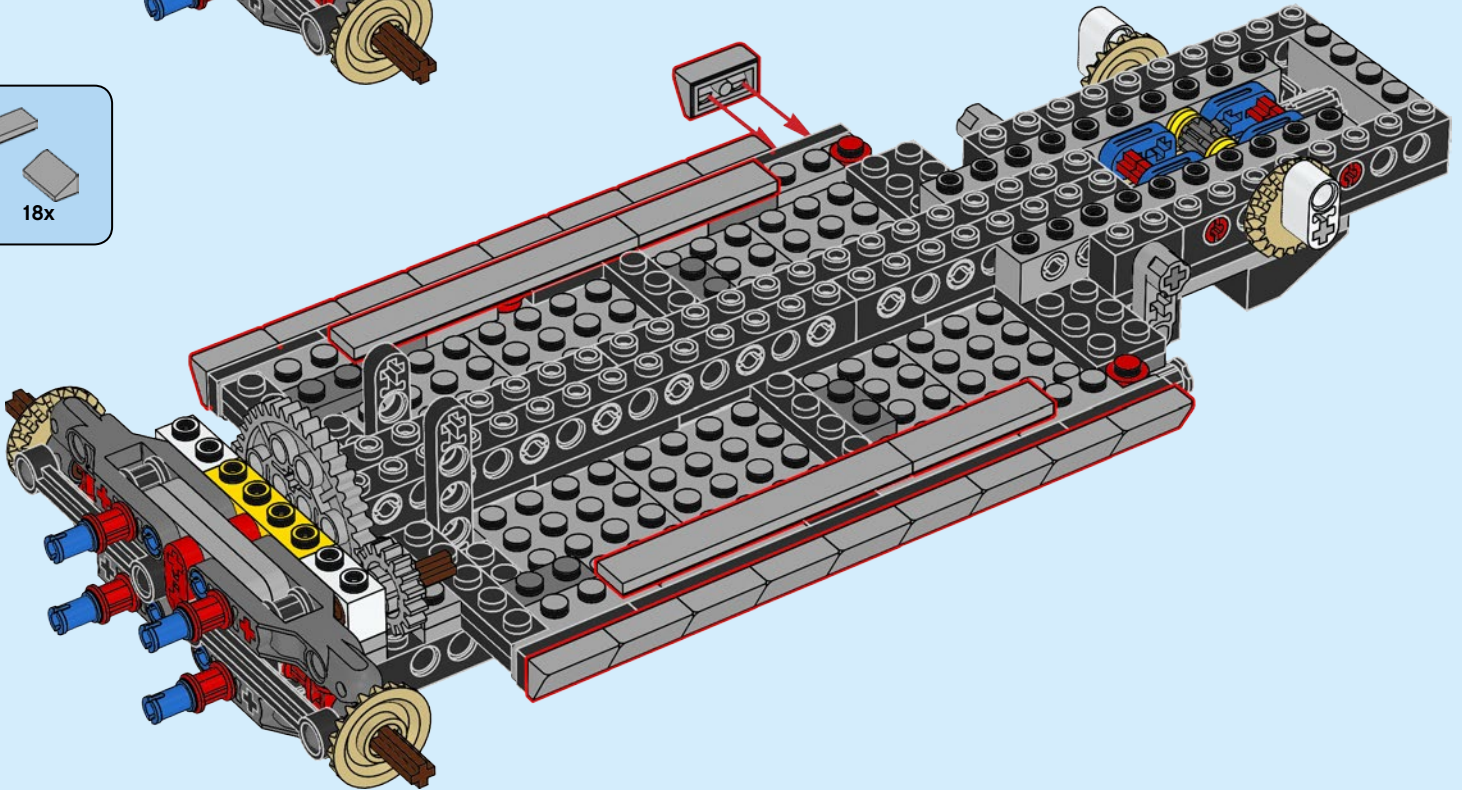

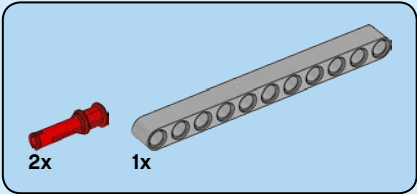
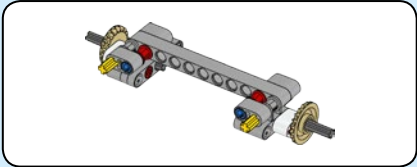
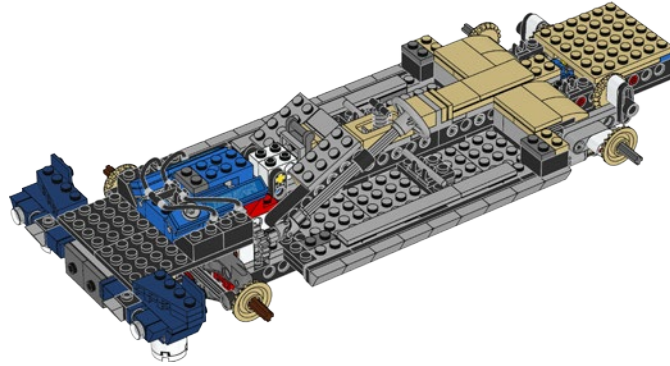
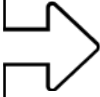
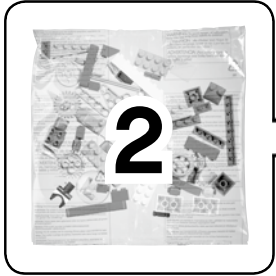

56

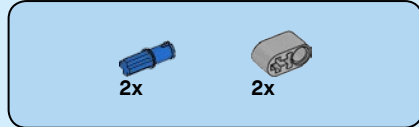
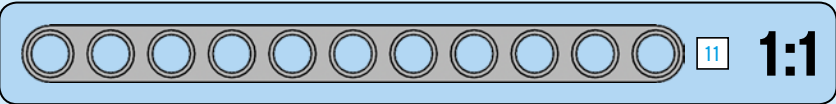
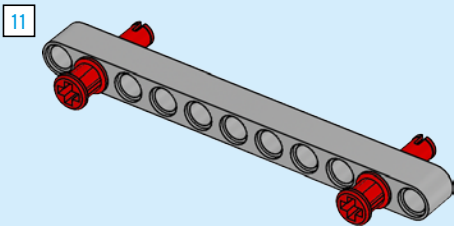

57

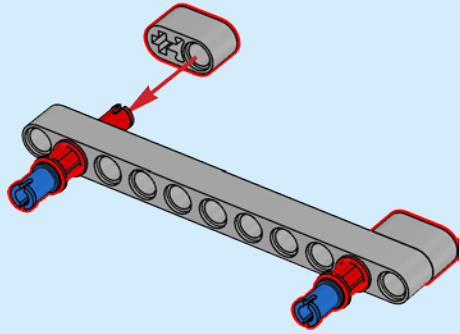

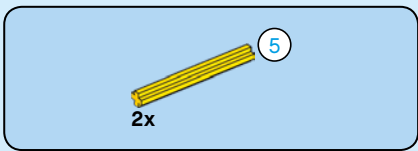

58

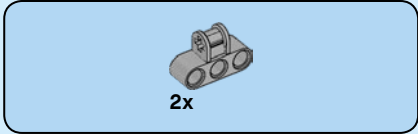
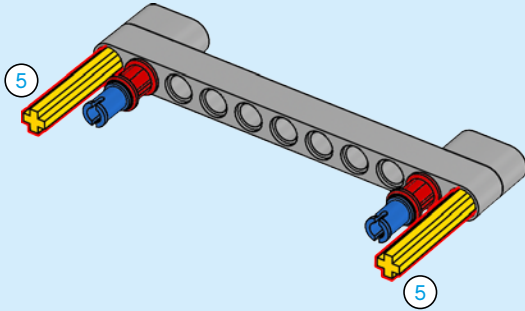

59

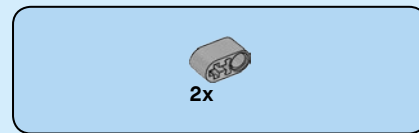
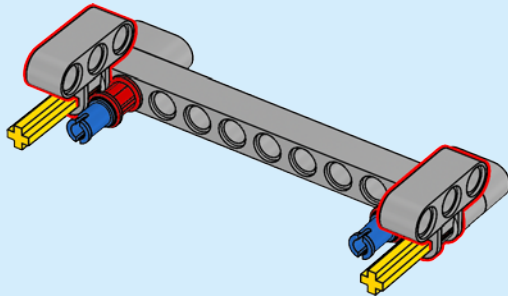

60

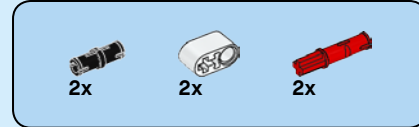
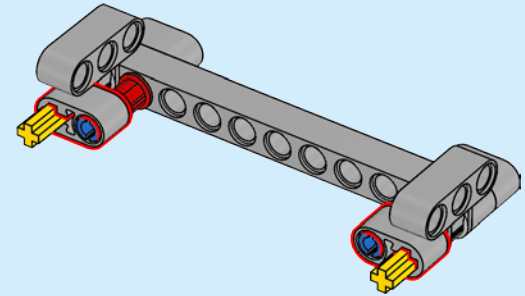

61

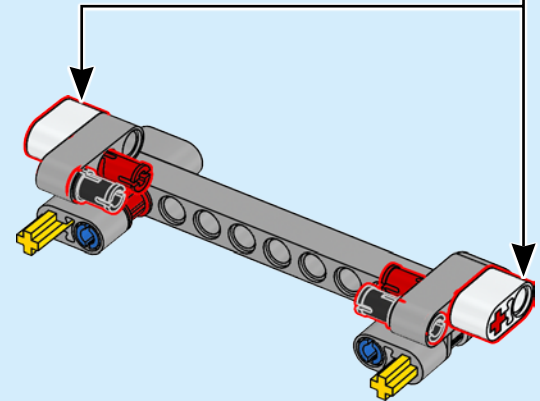
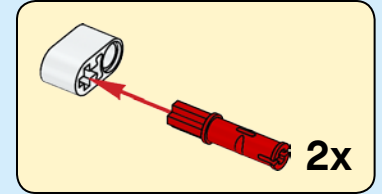

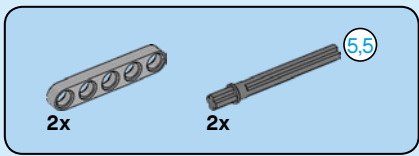

62

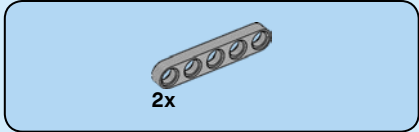
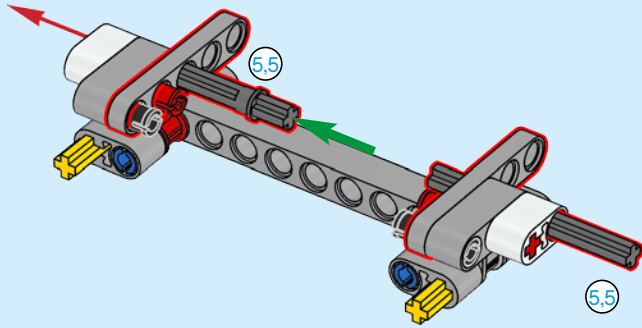

63

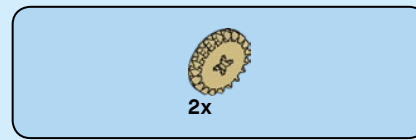
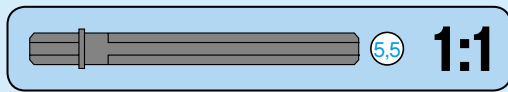
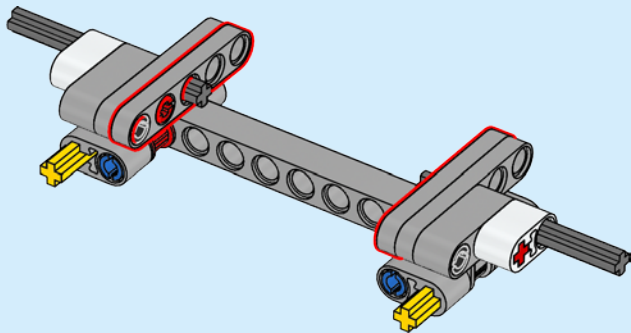

64

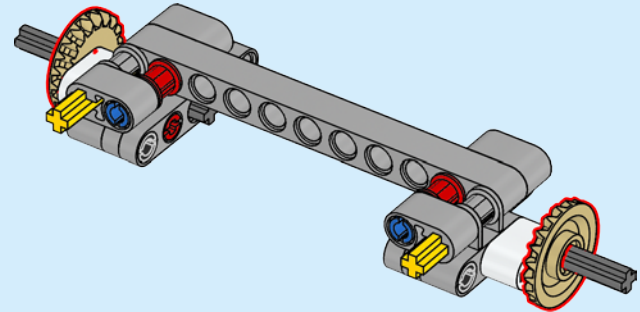
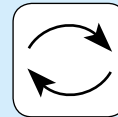

65

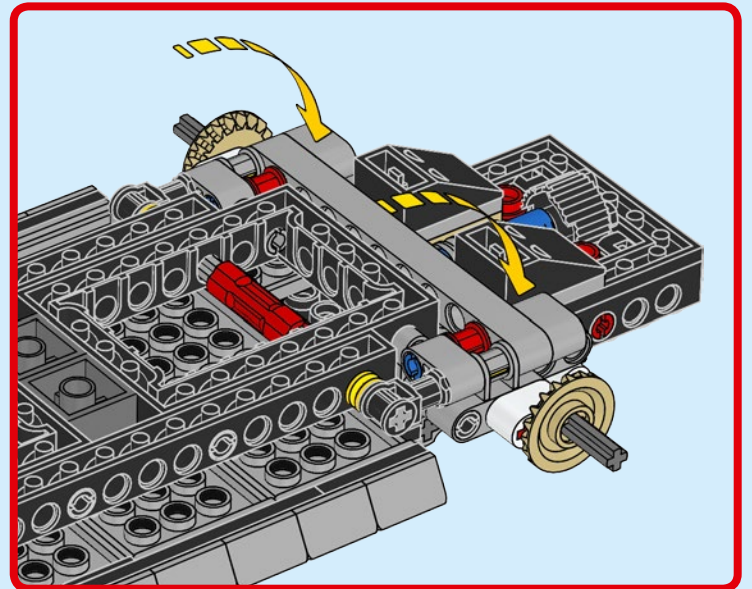
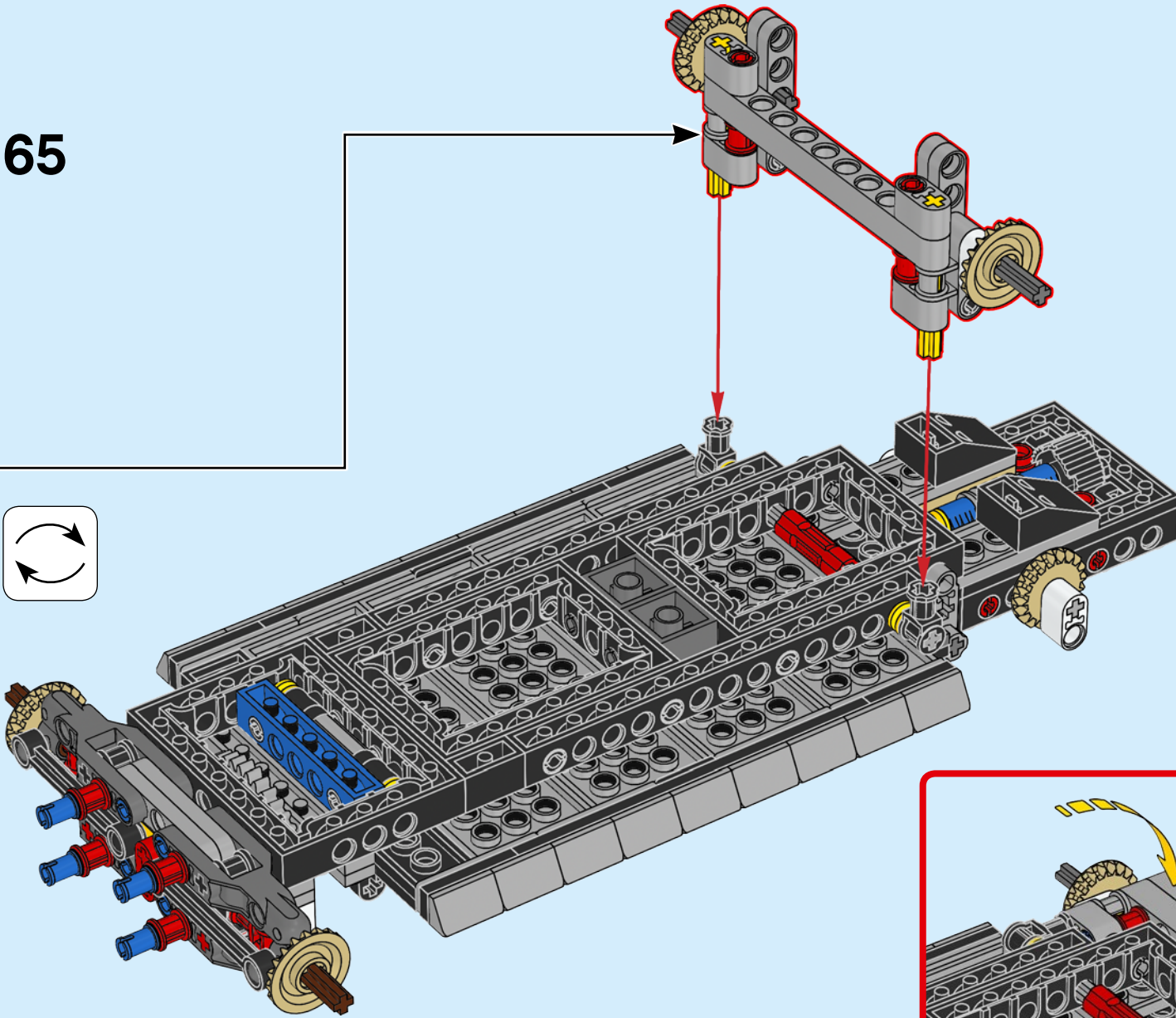
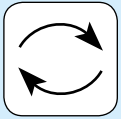



2x

66

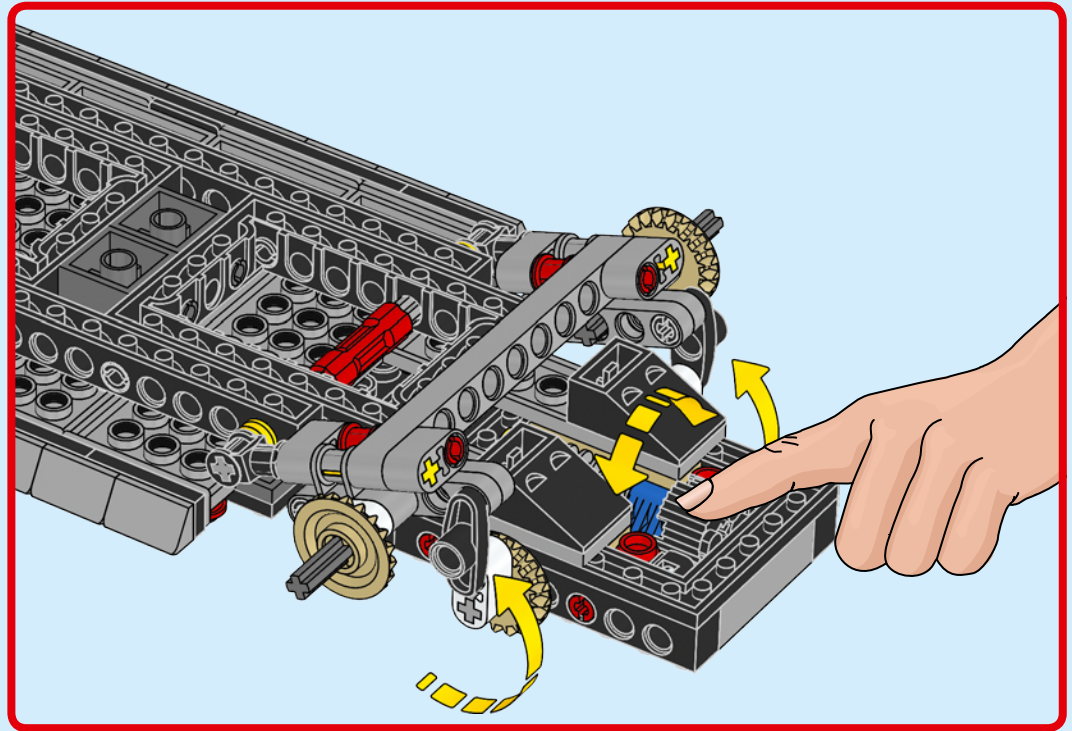
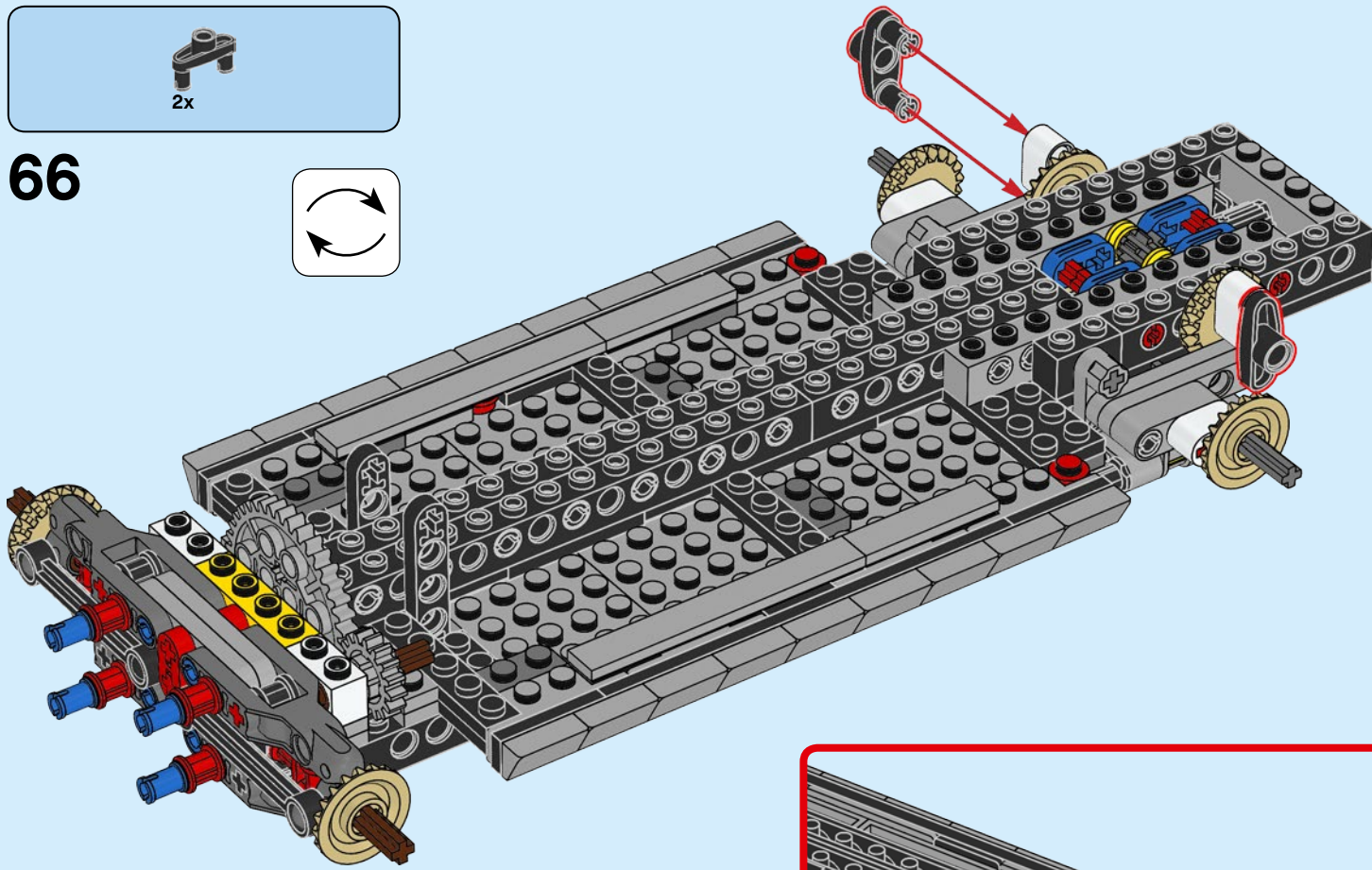
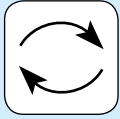

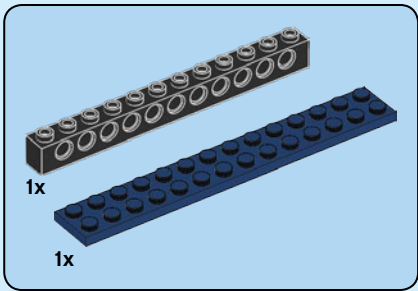
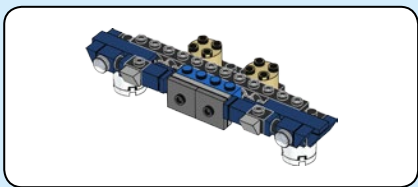

67

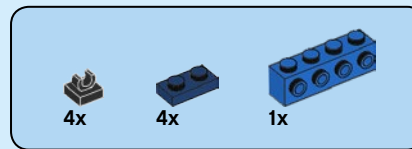
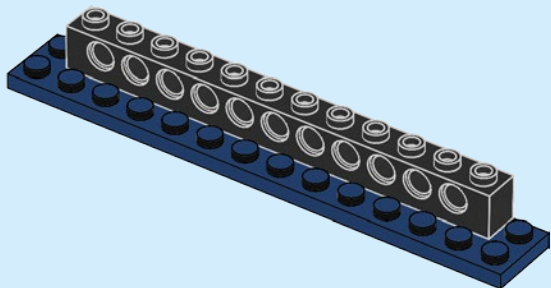

68

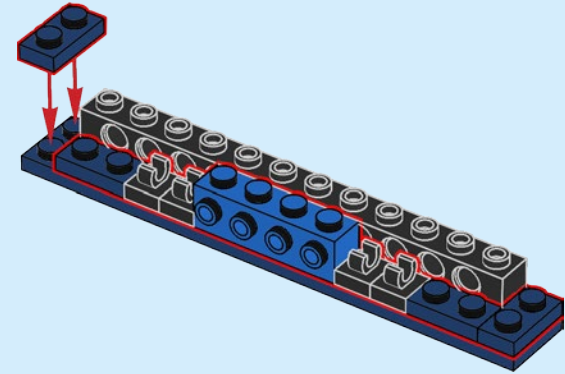

69

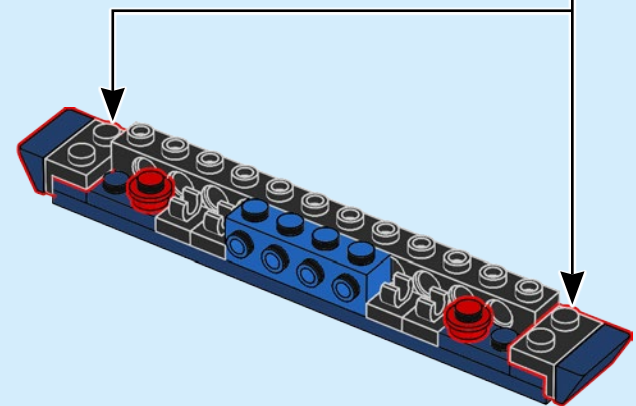
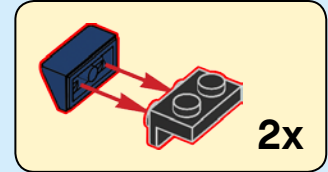

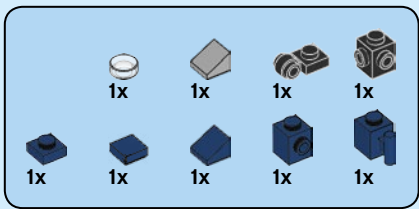

70

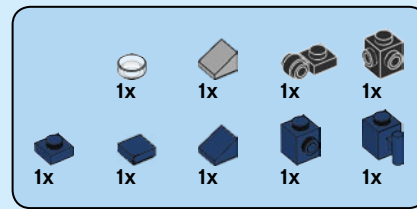
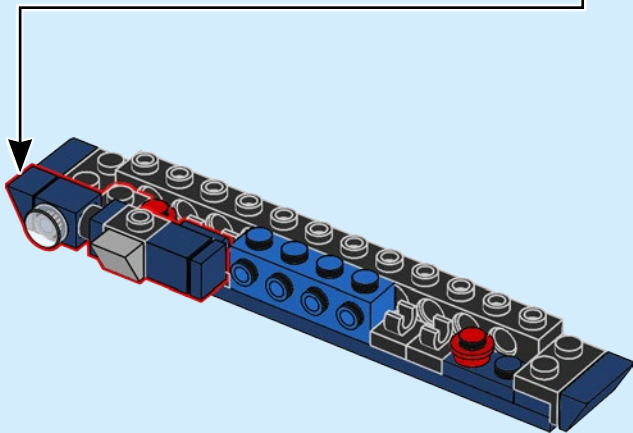
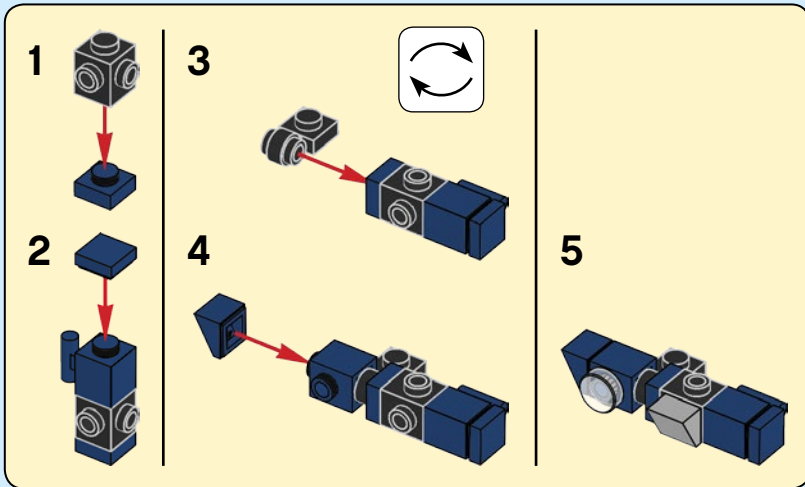

71

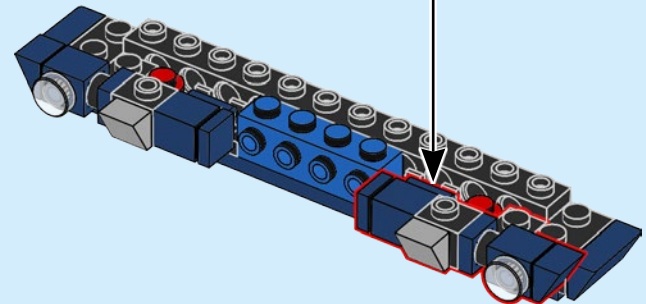
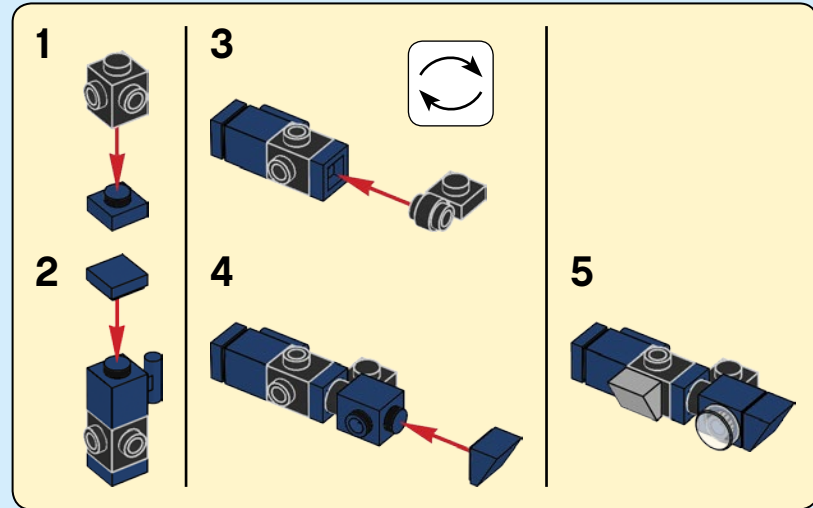

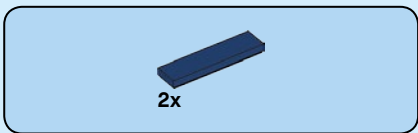

72

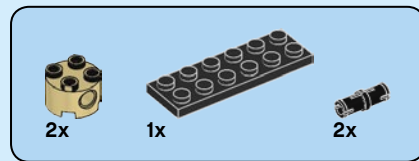
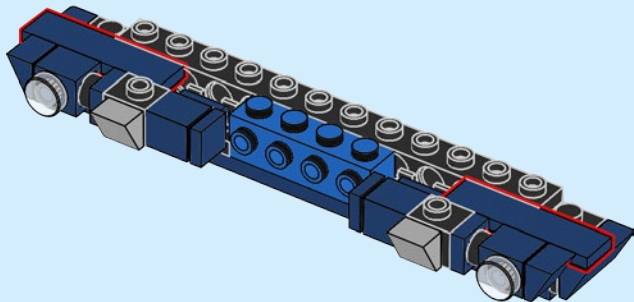

73

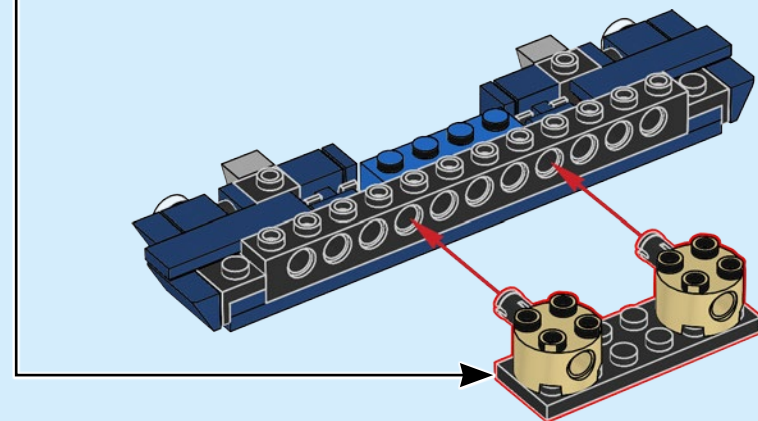
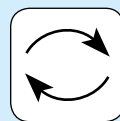
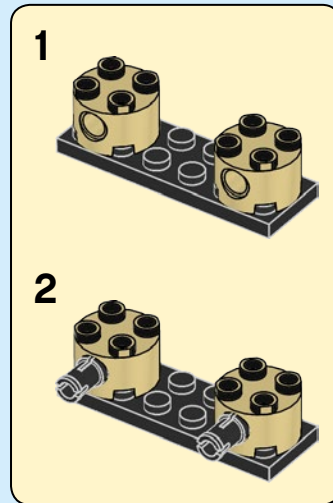

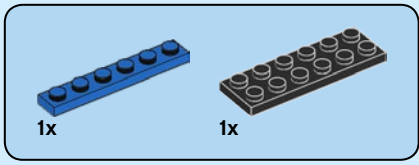

74

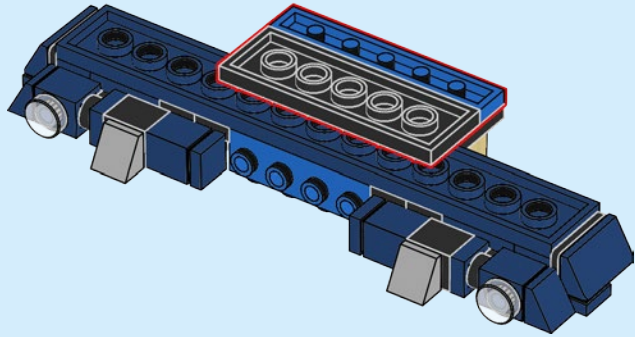
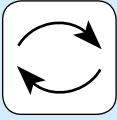

75

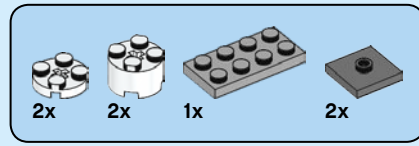
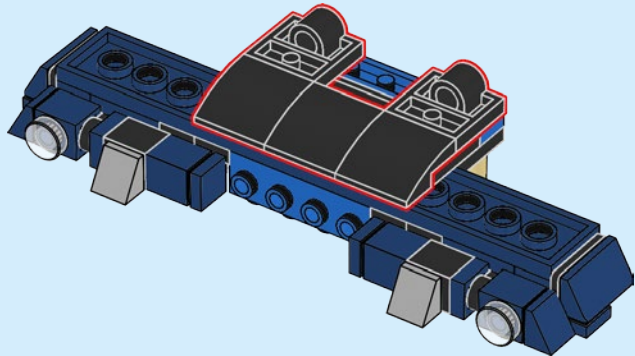

76

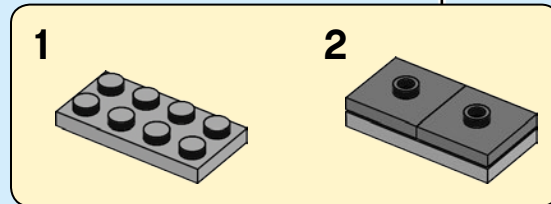
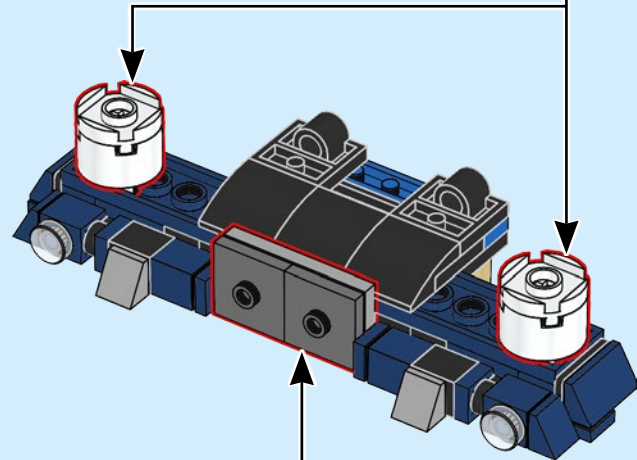
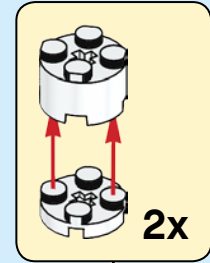

77

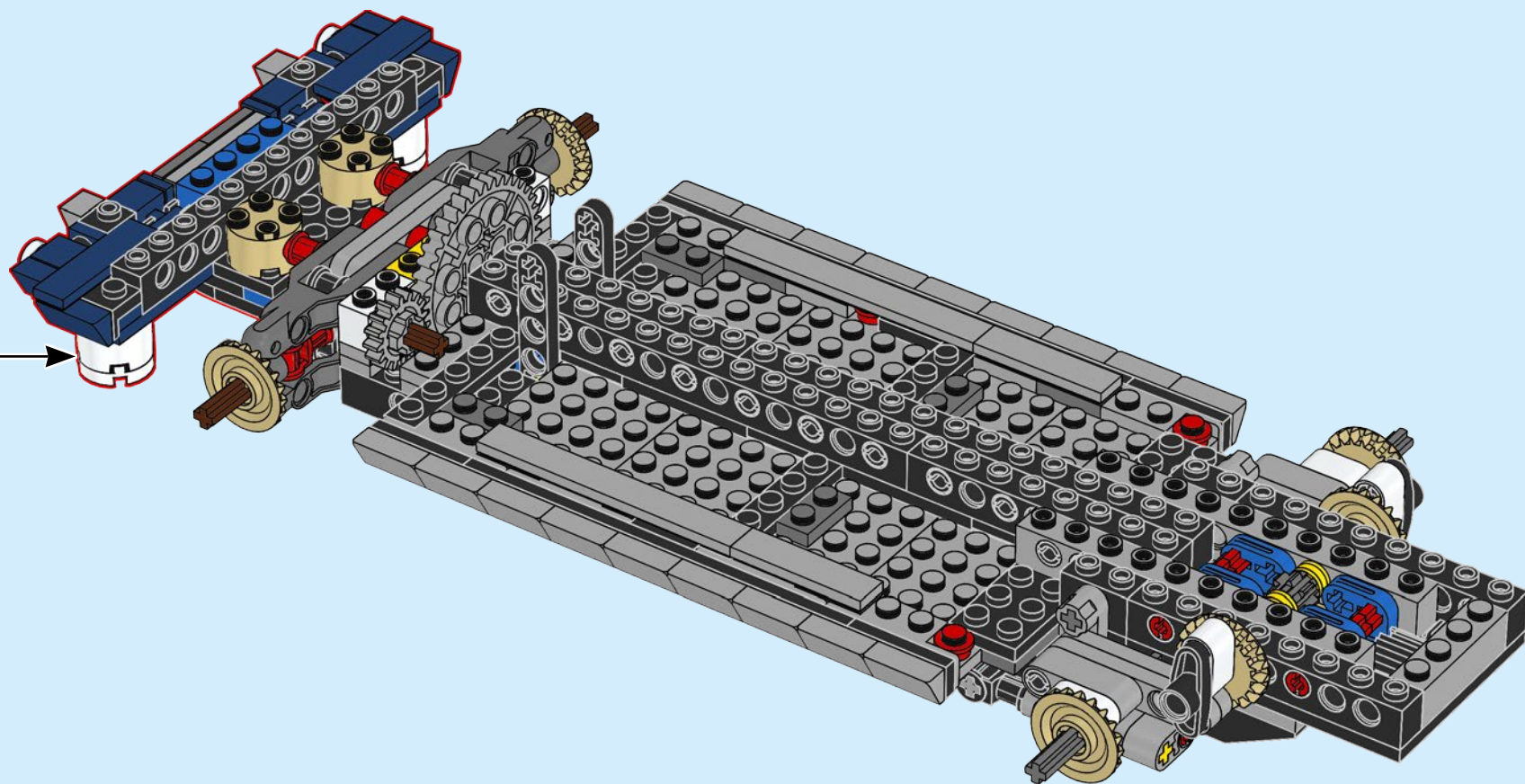

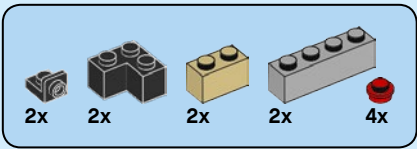

78

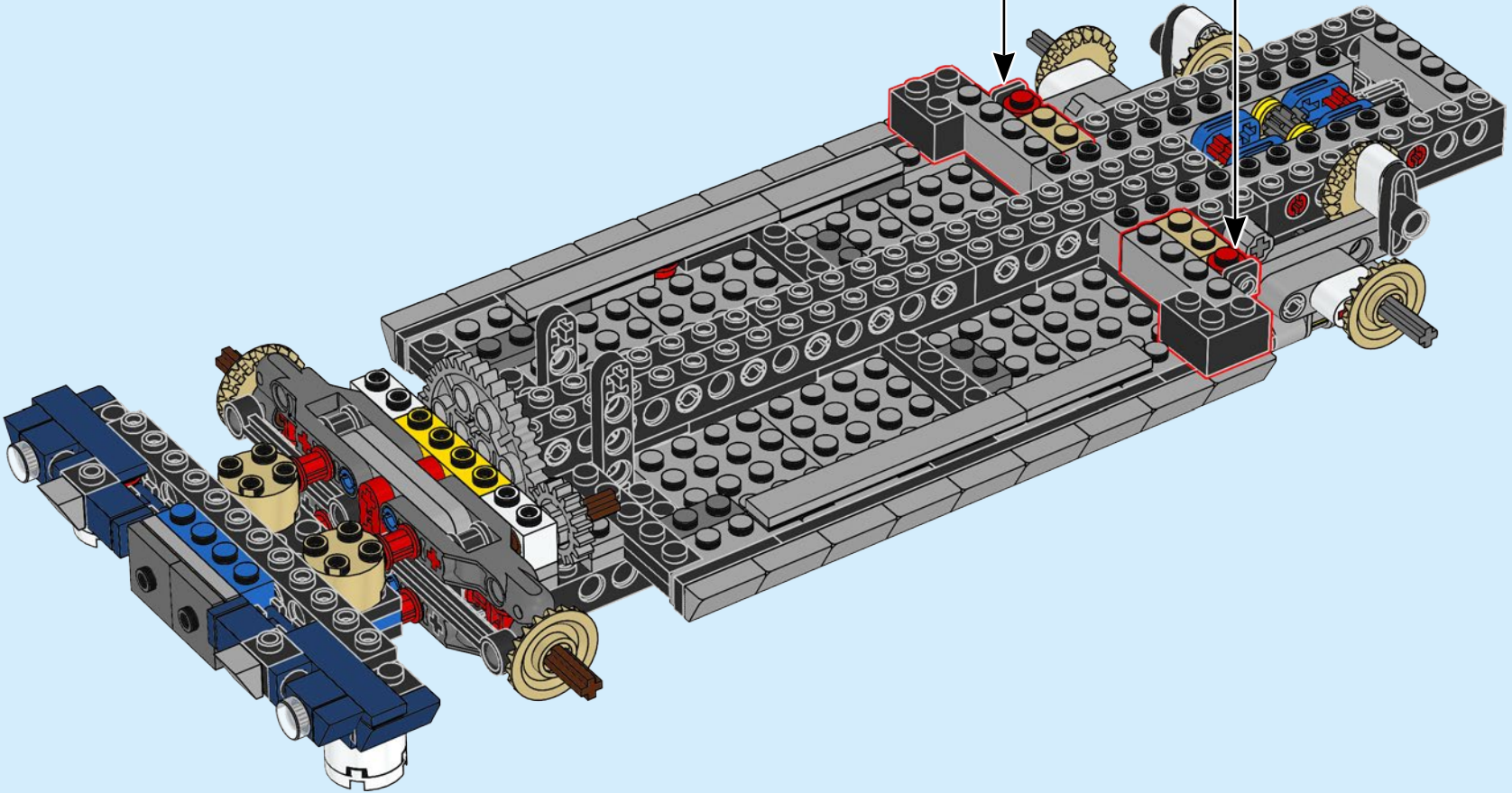
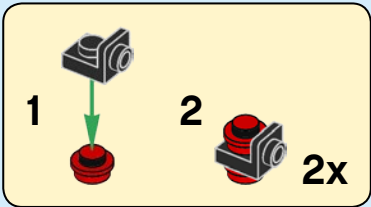

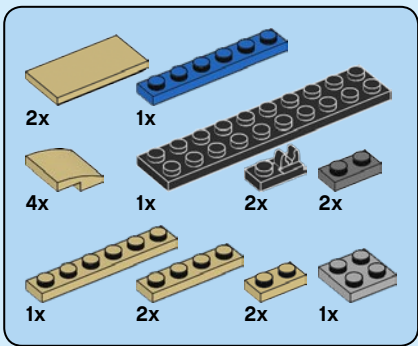

79

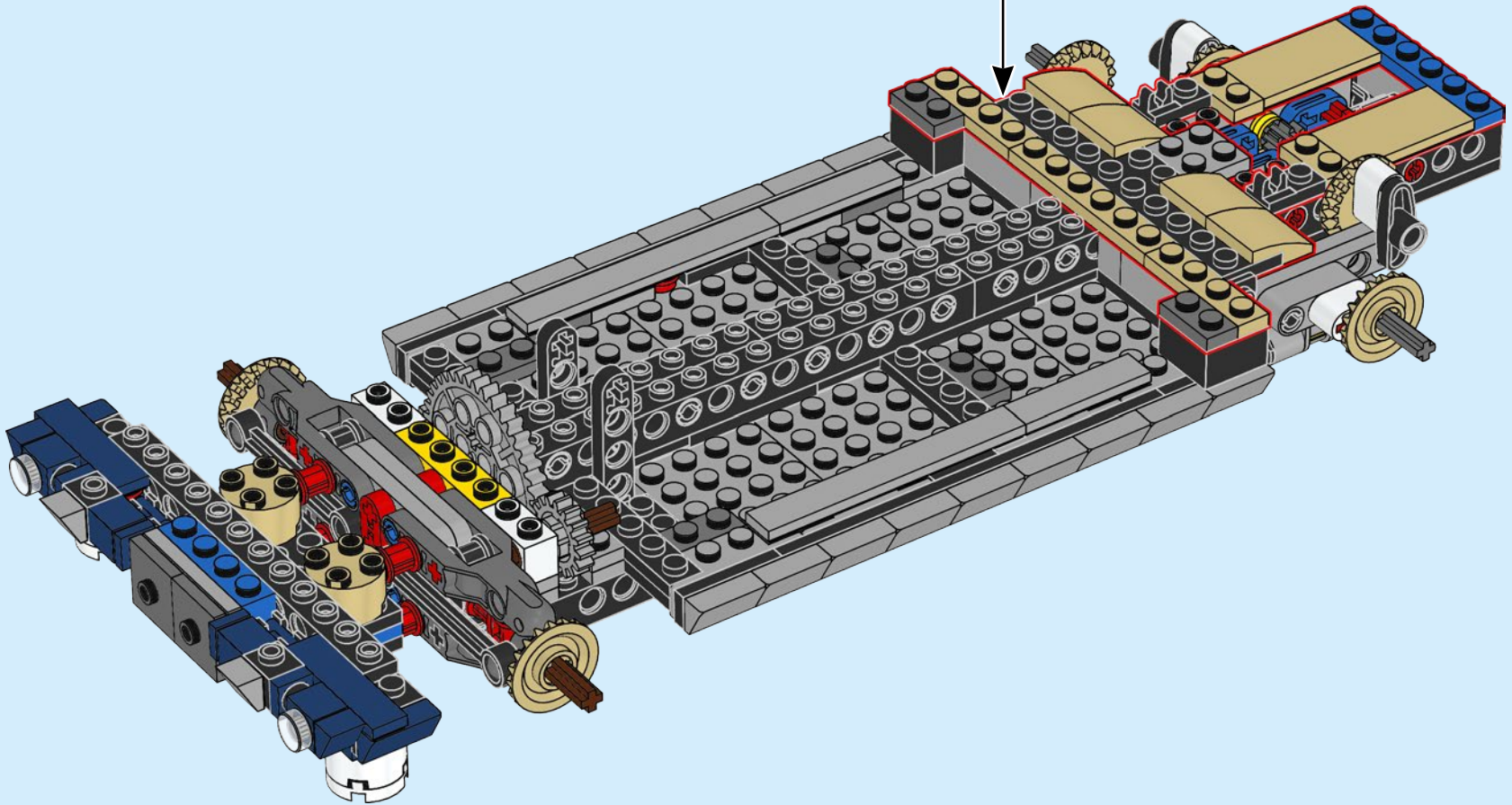
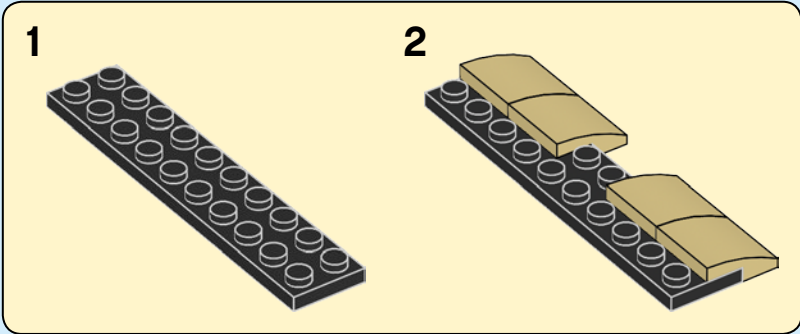

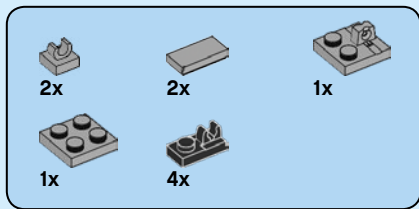

80

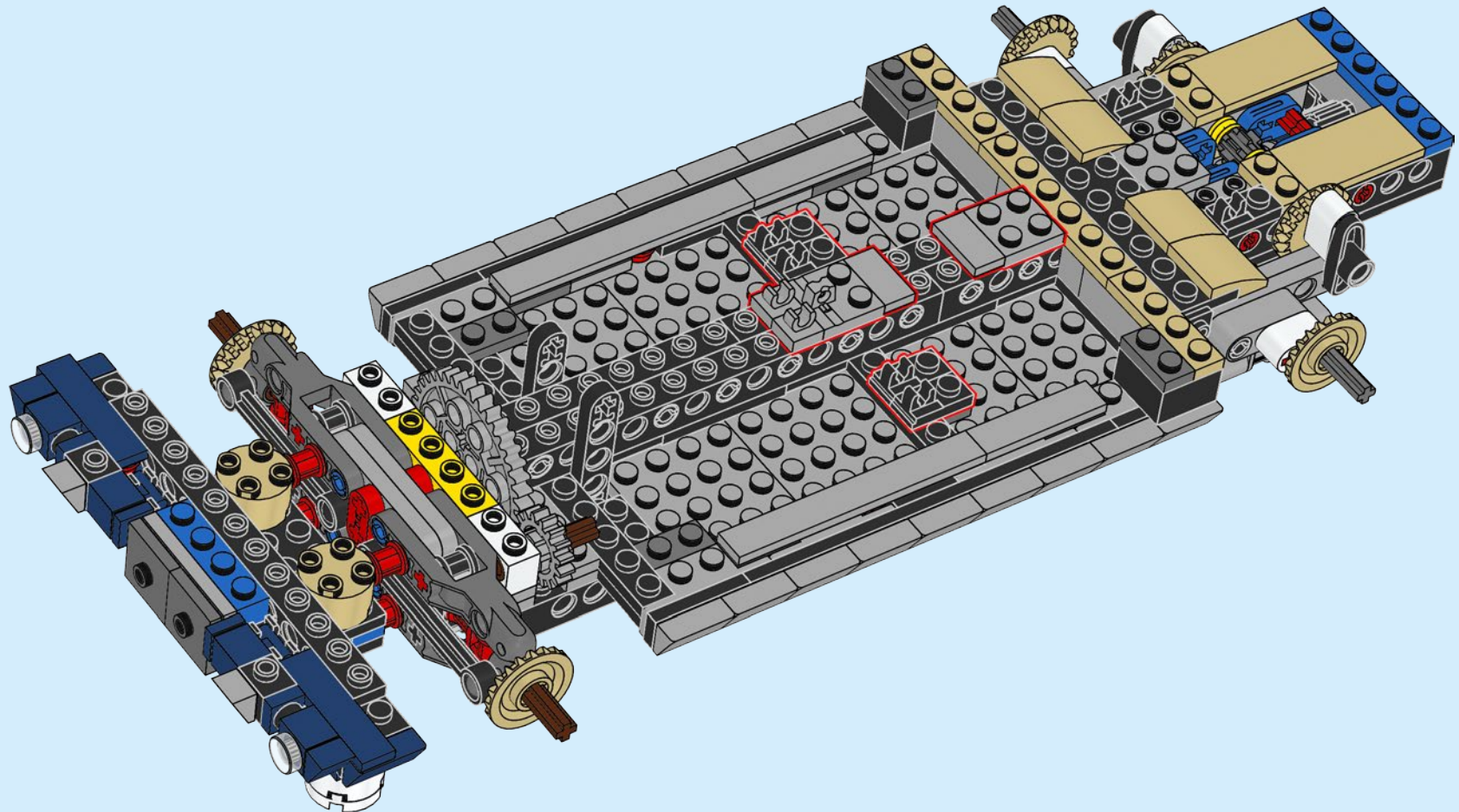

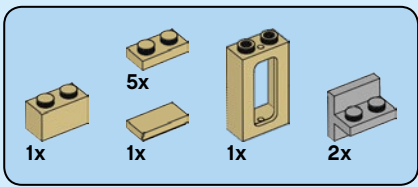

81

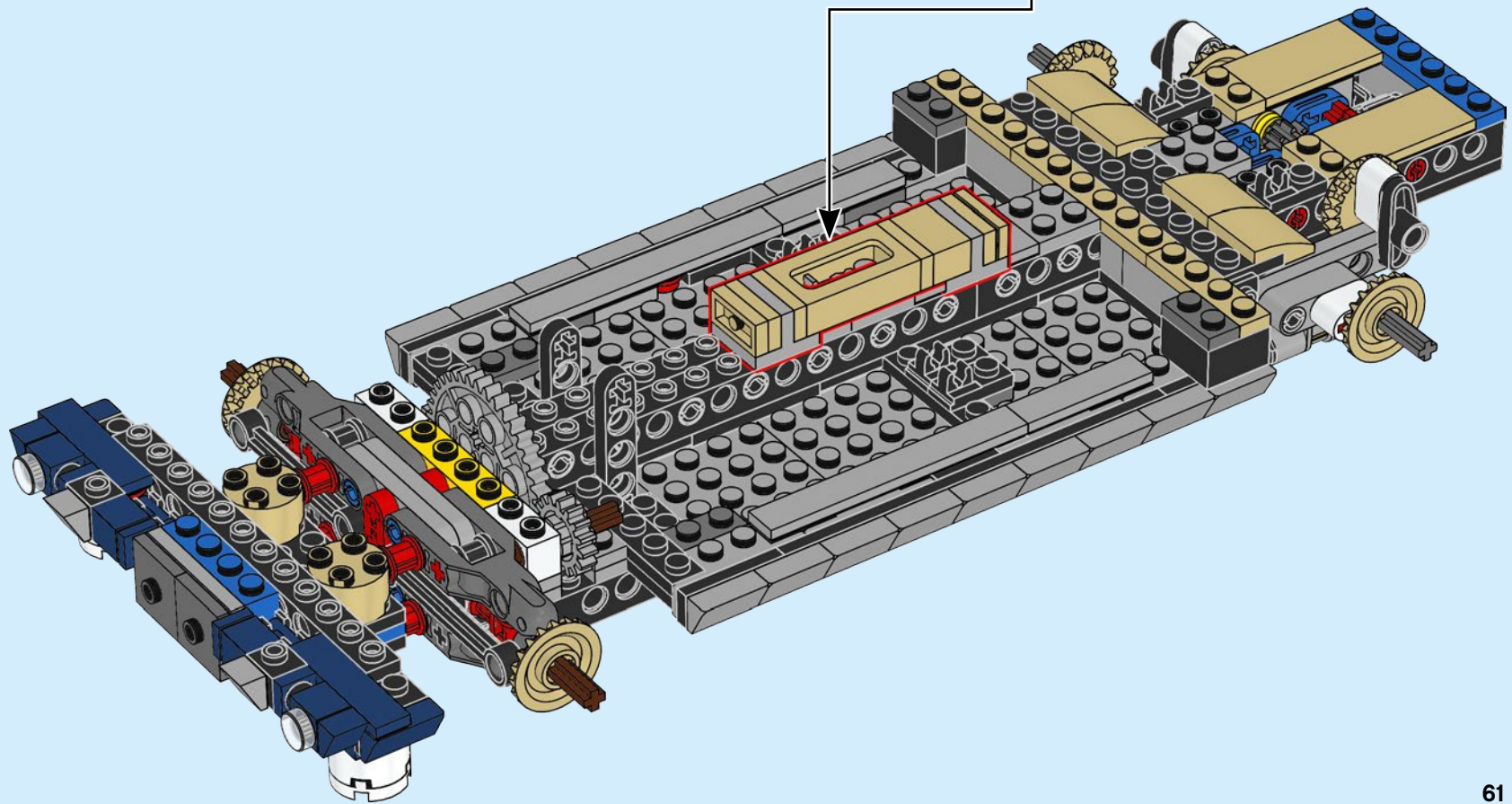
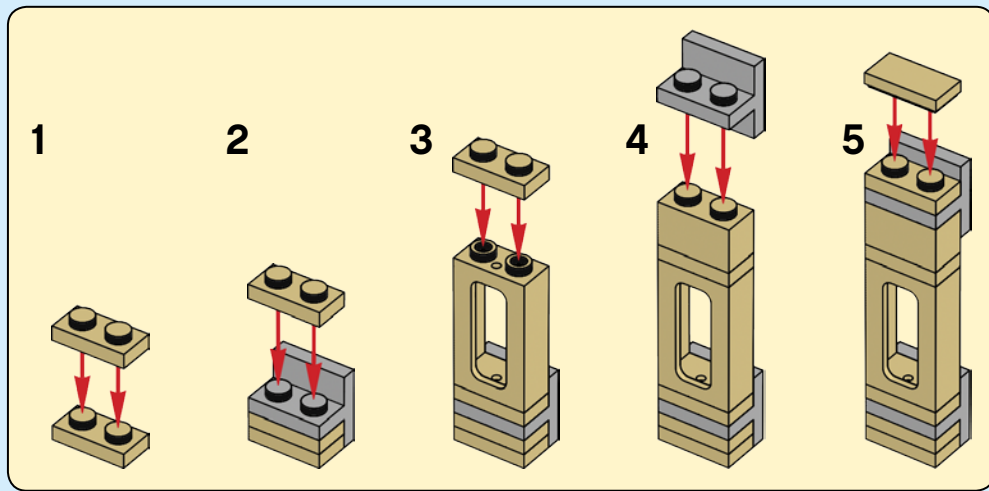



82

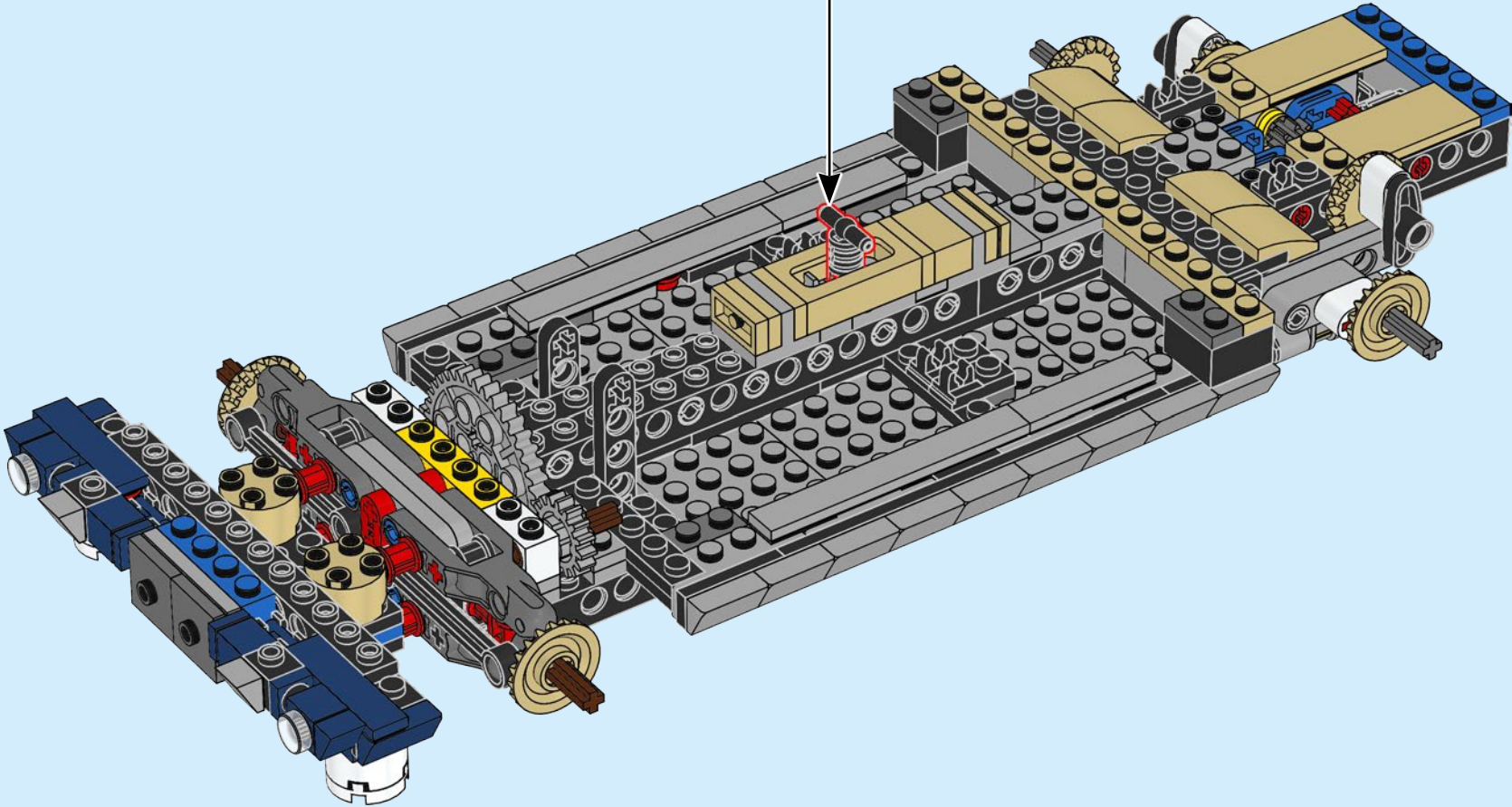
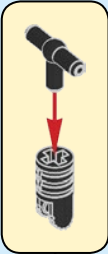

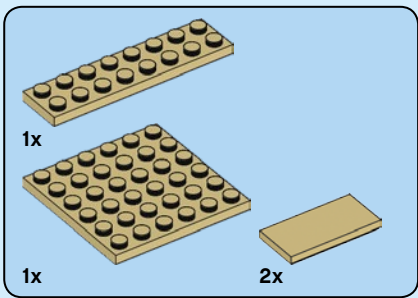

83

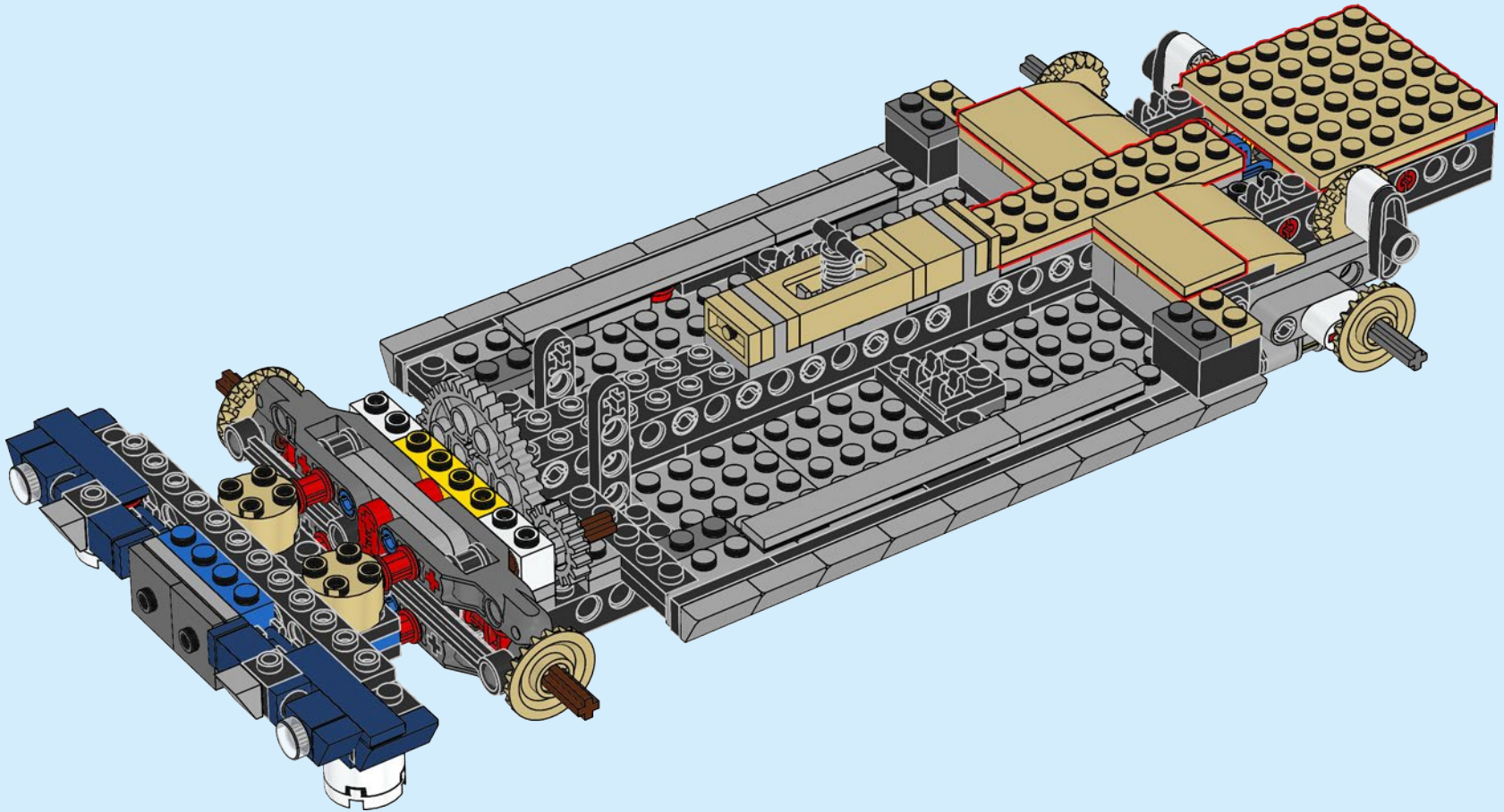

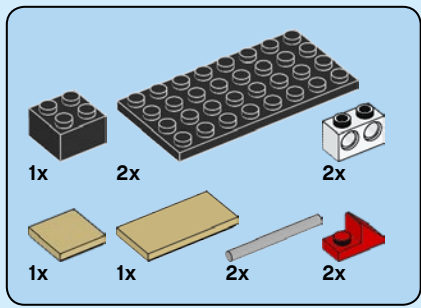

84

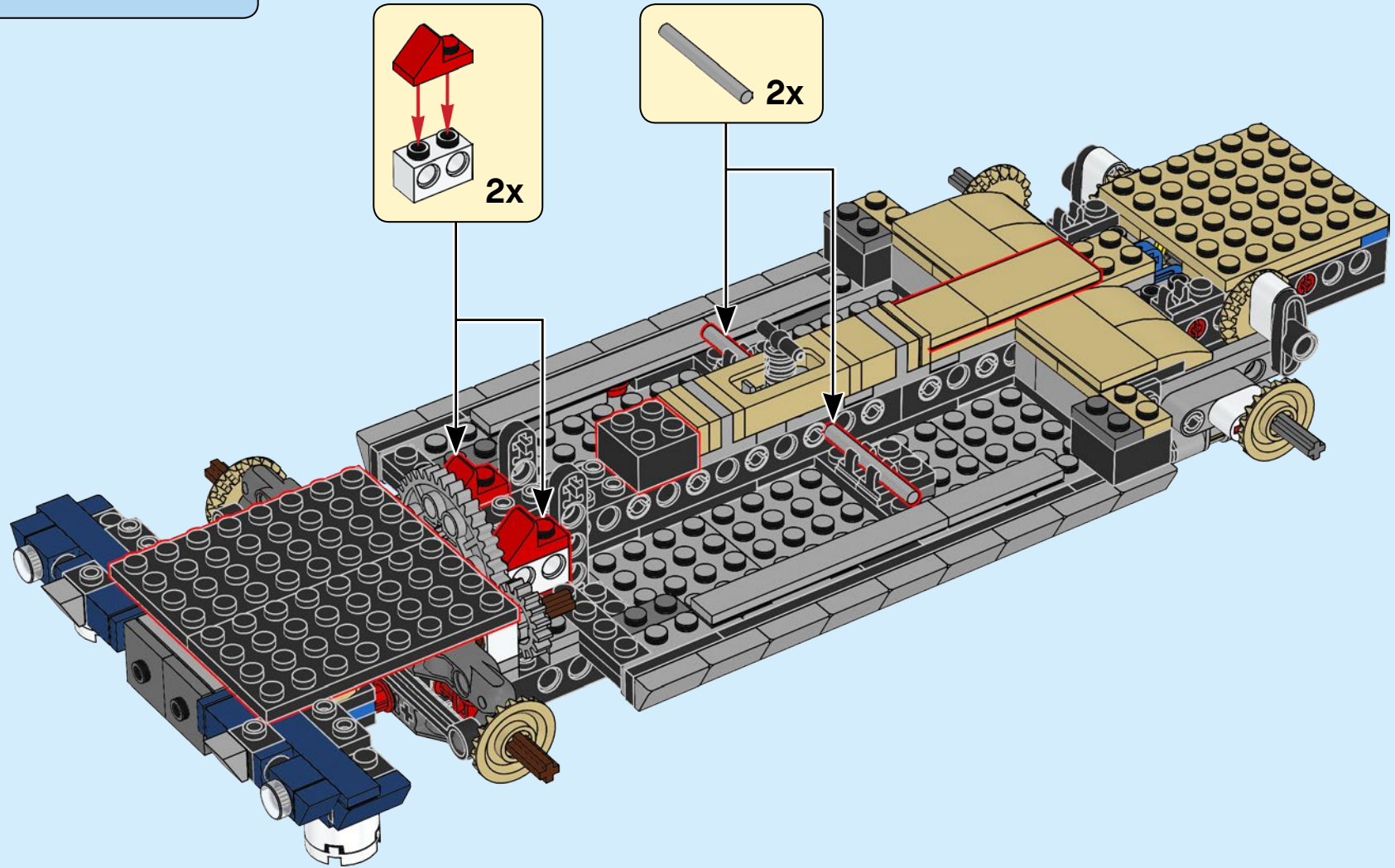

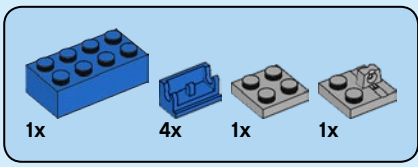

85

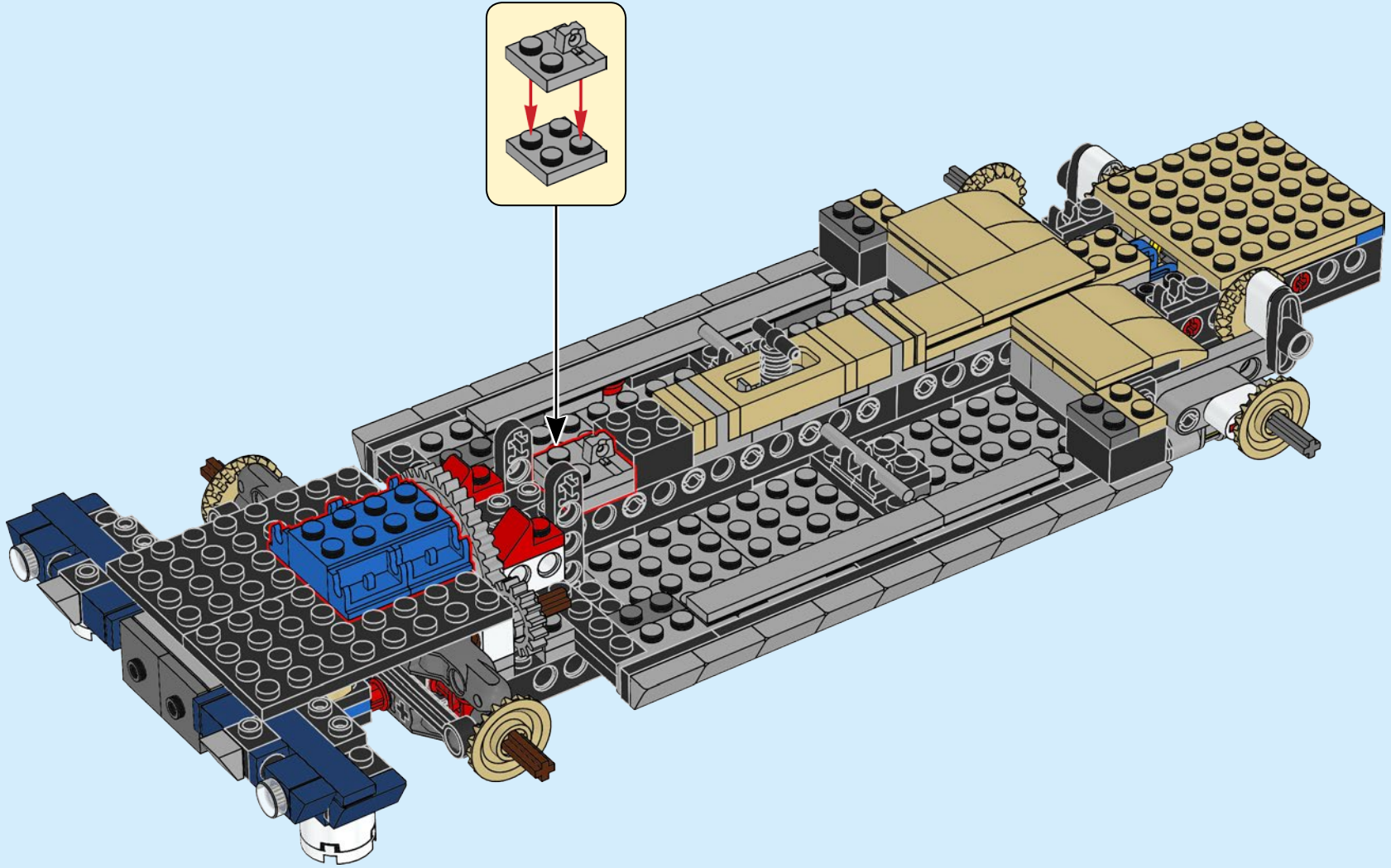

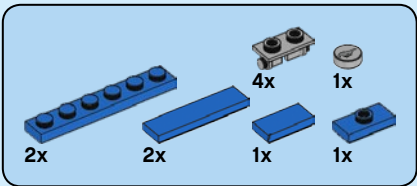

86

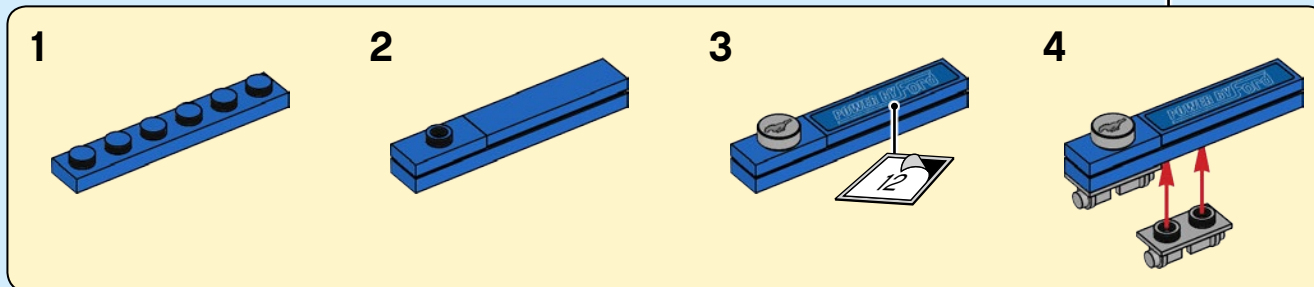
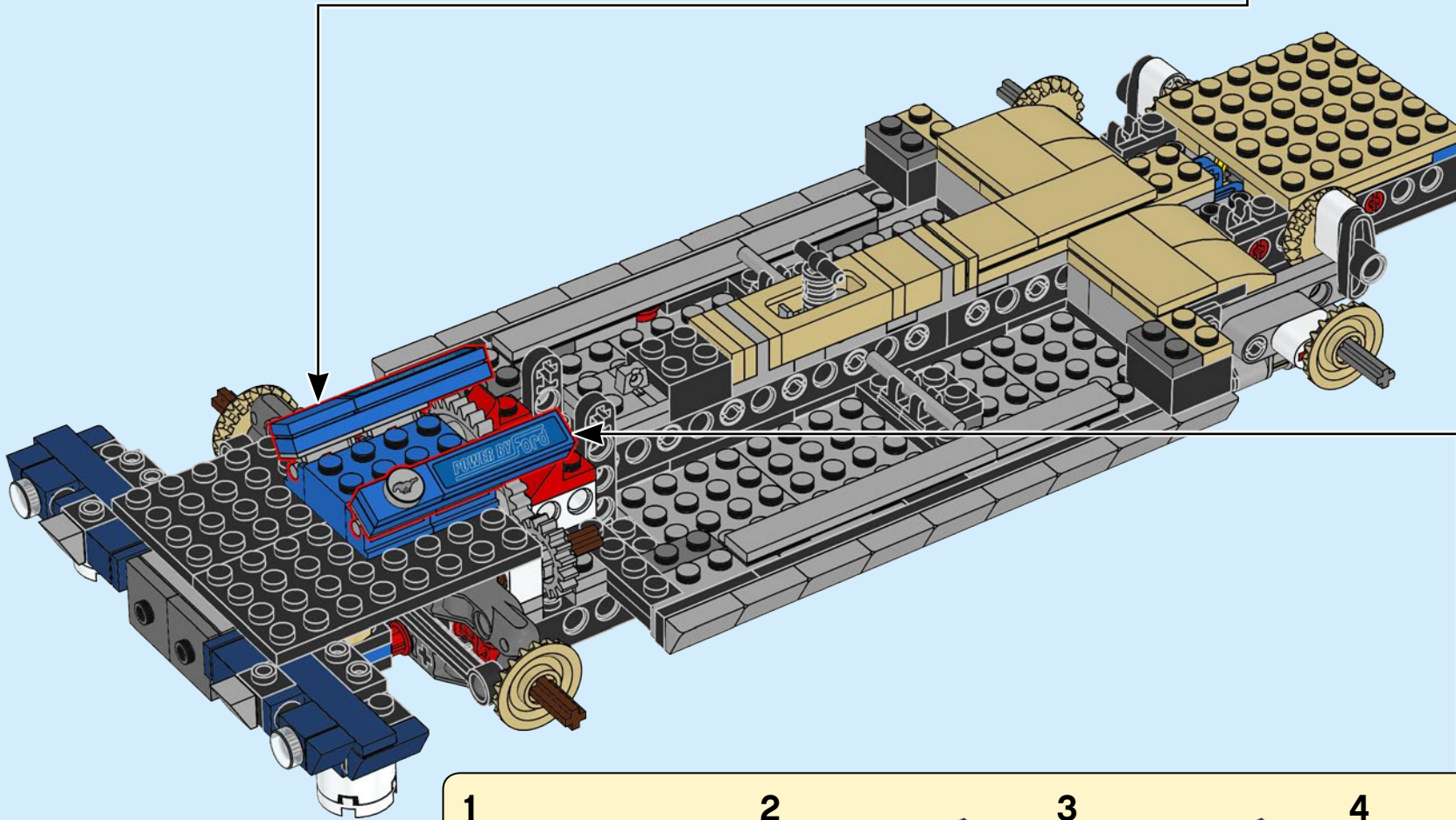
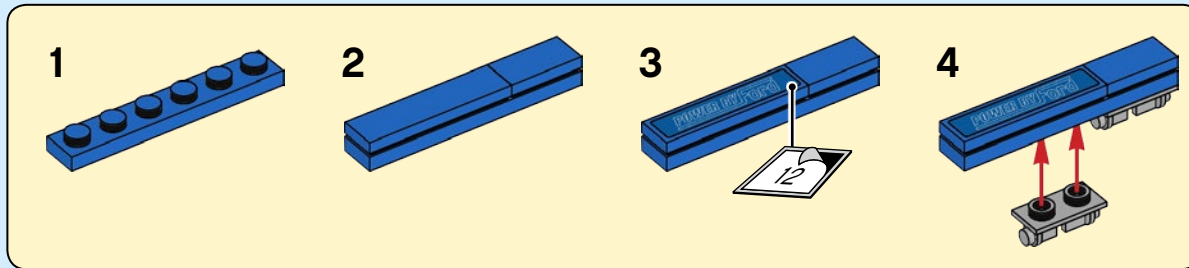



87

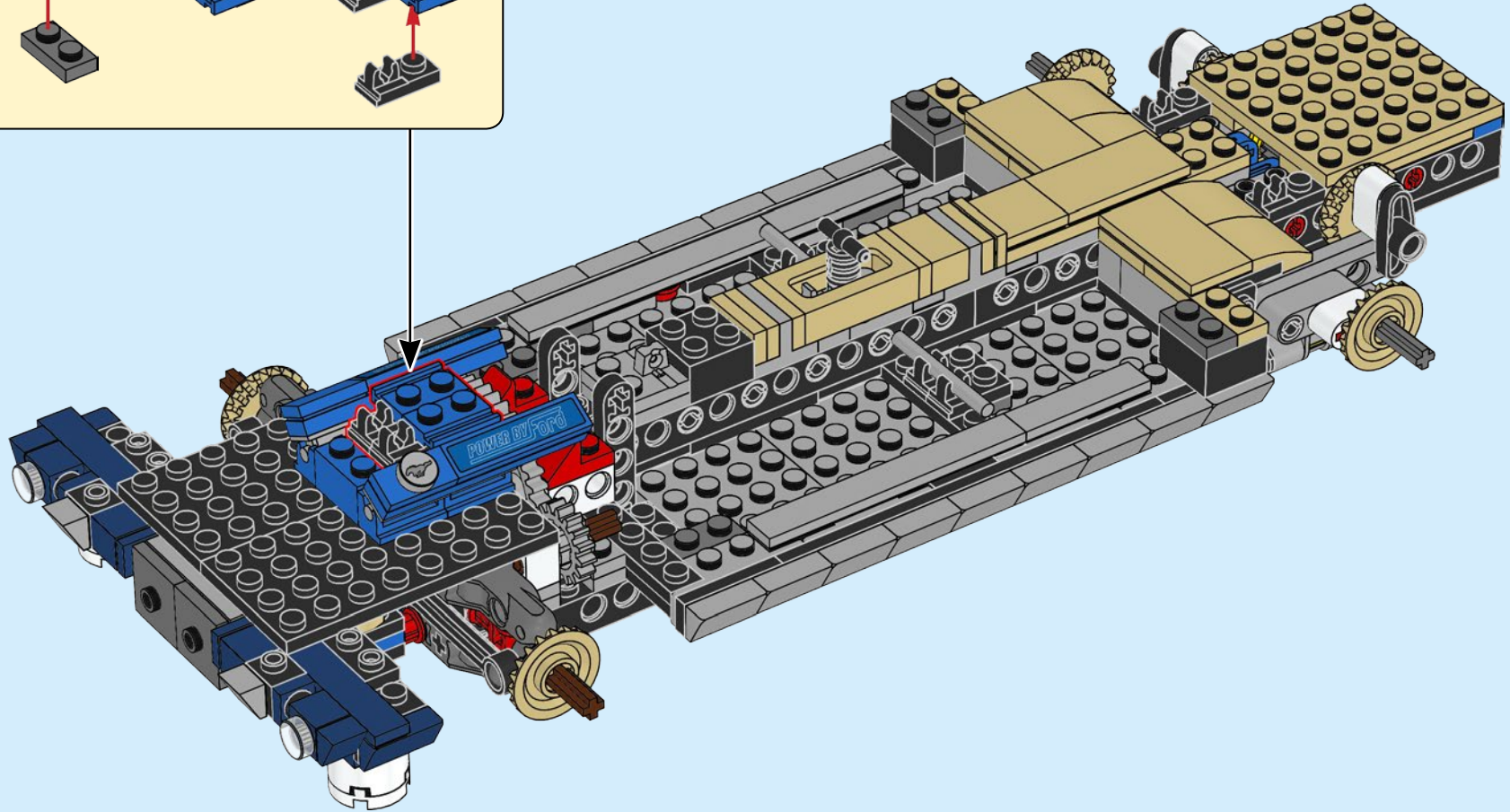
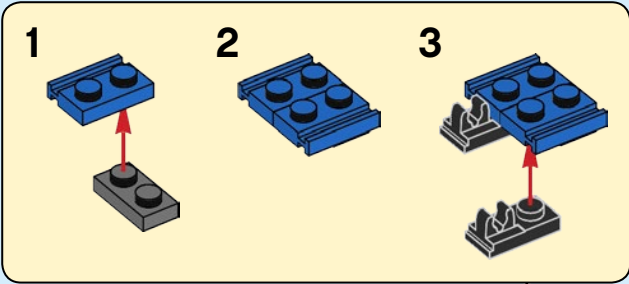

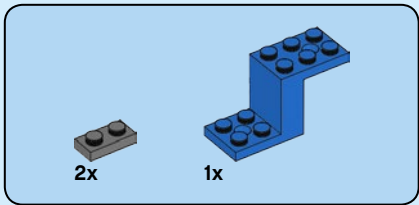

88

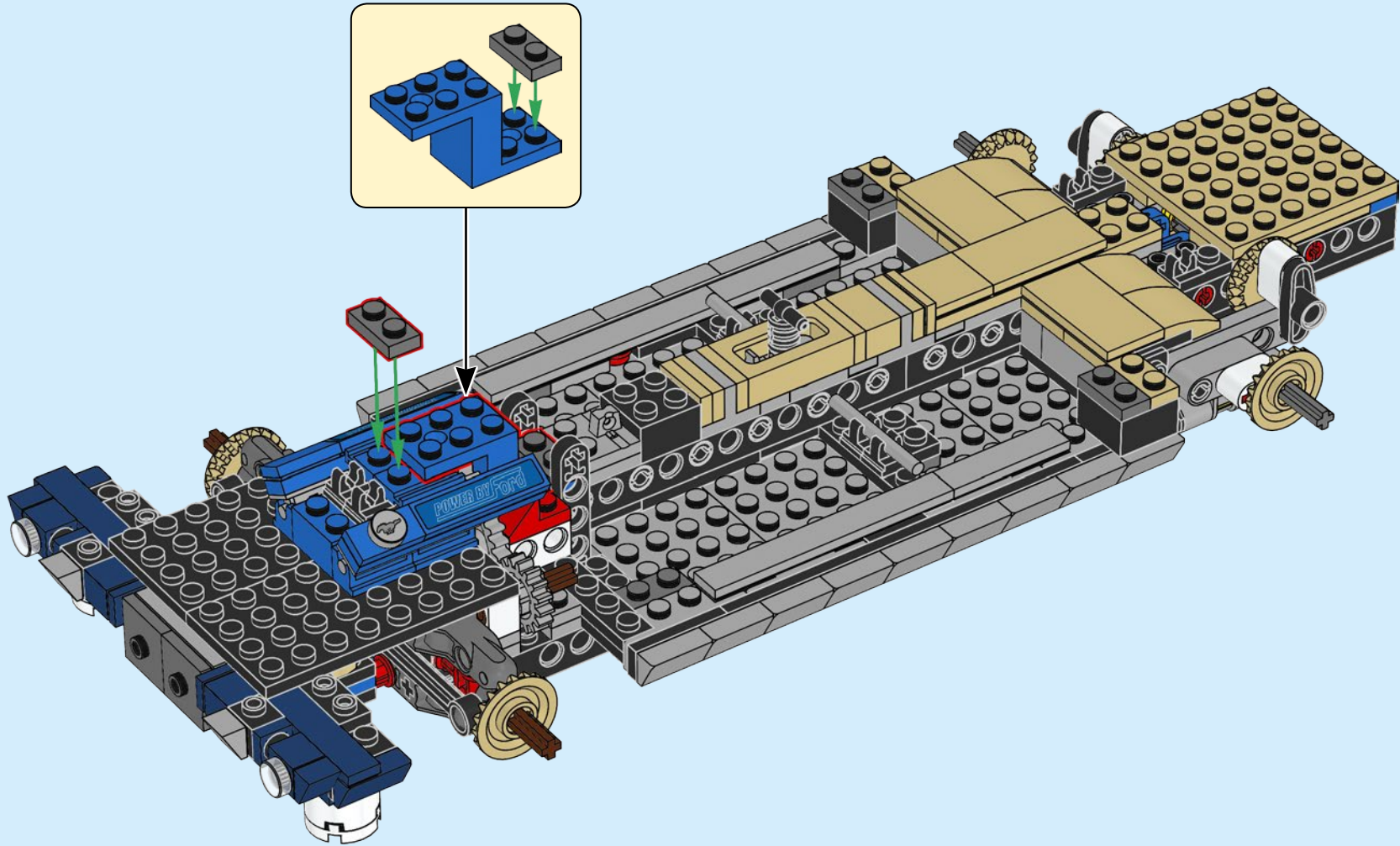

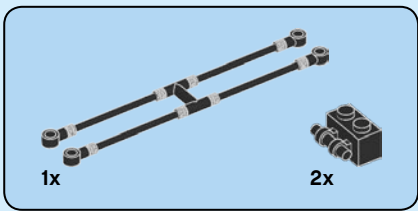

89

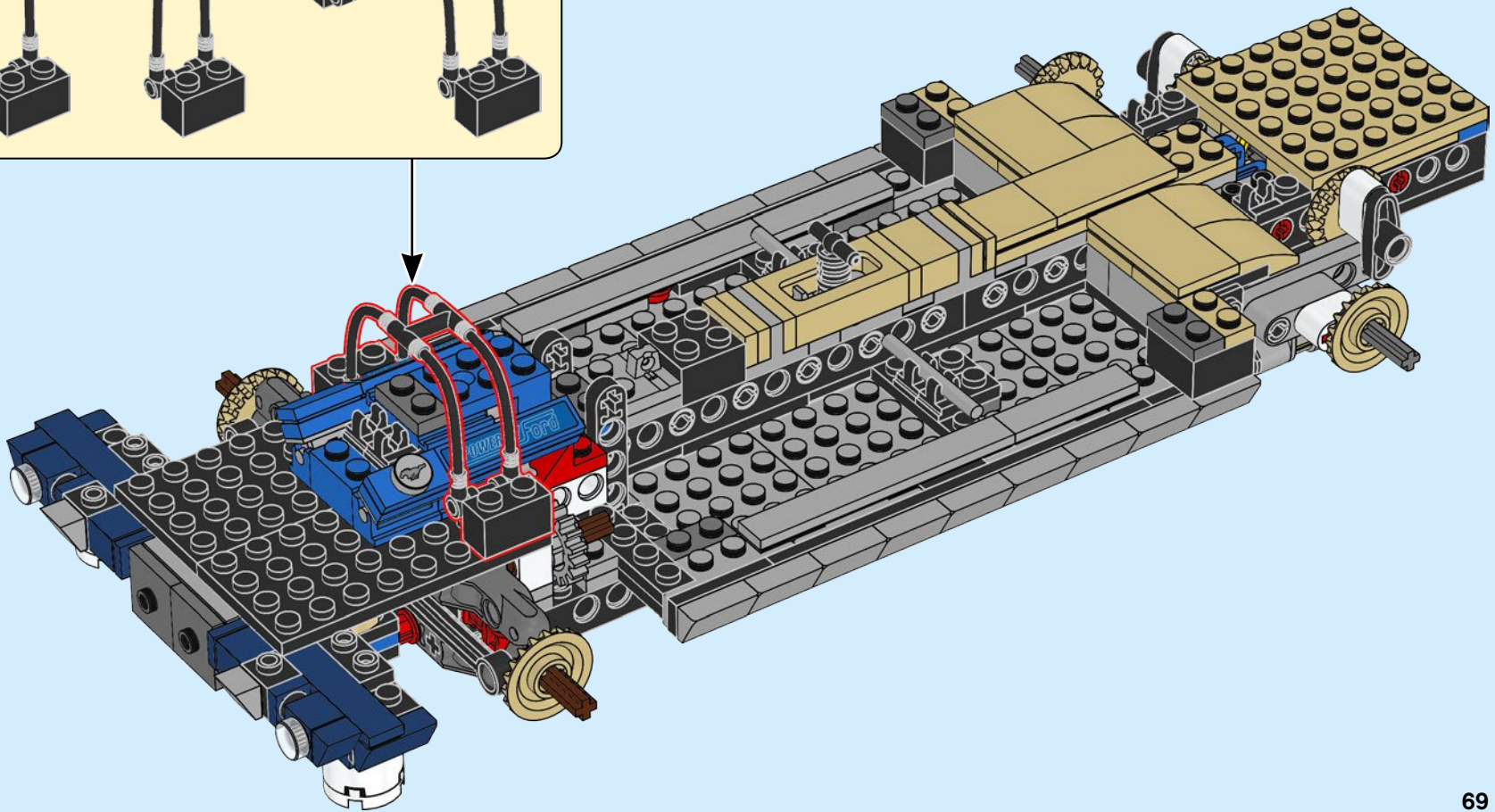
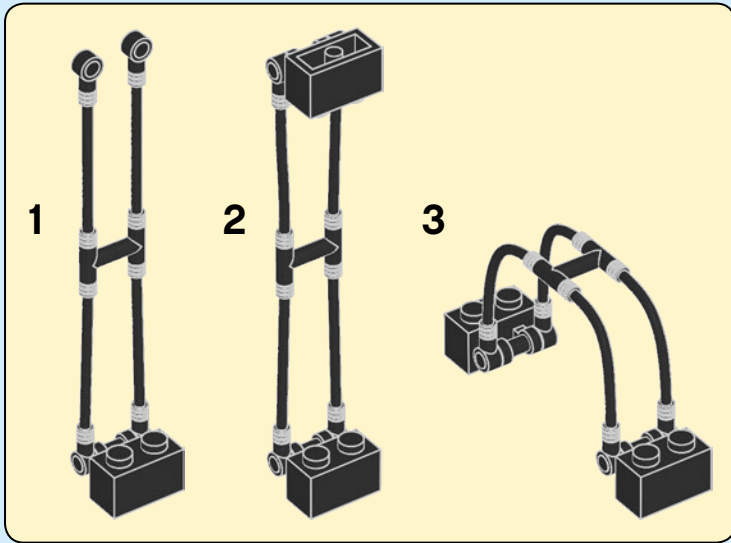



2x

90

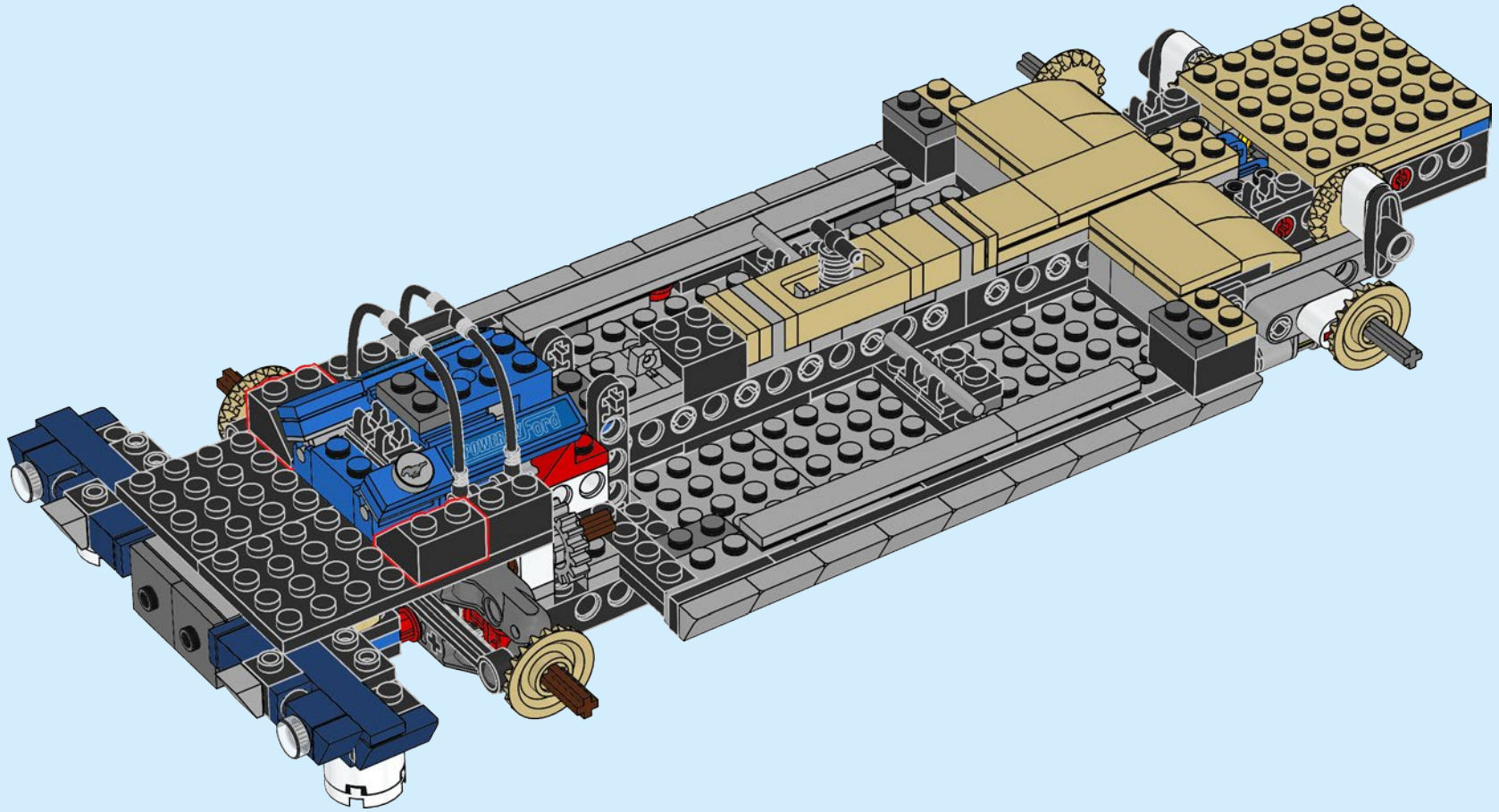

91

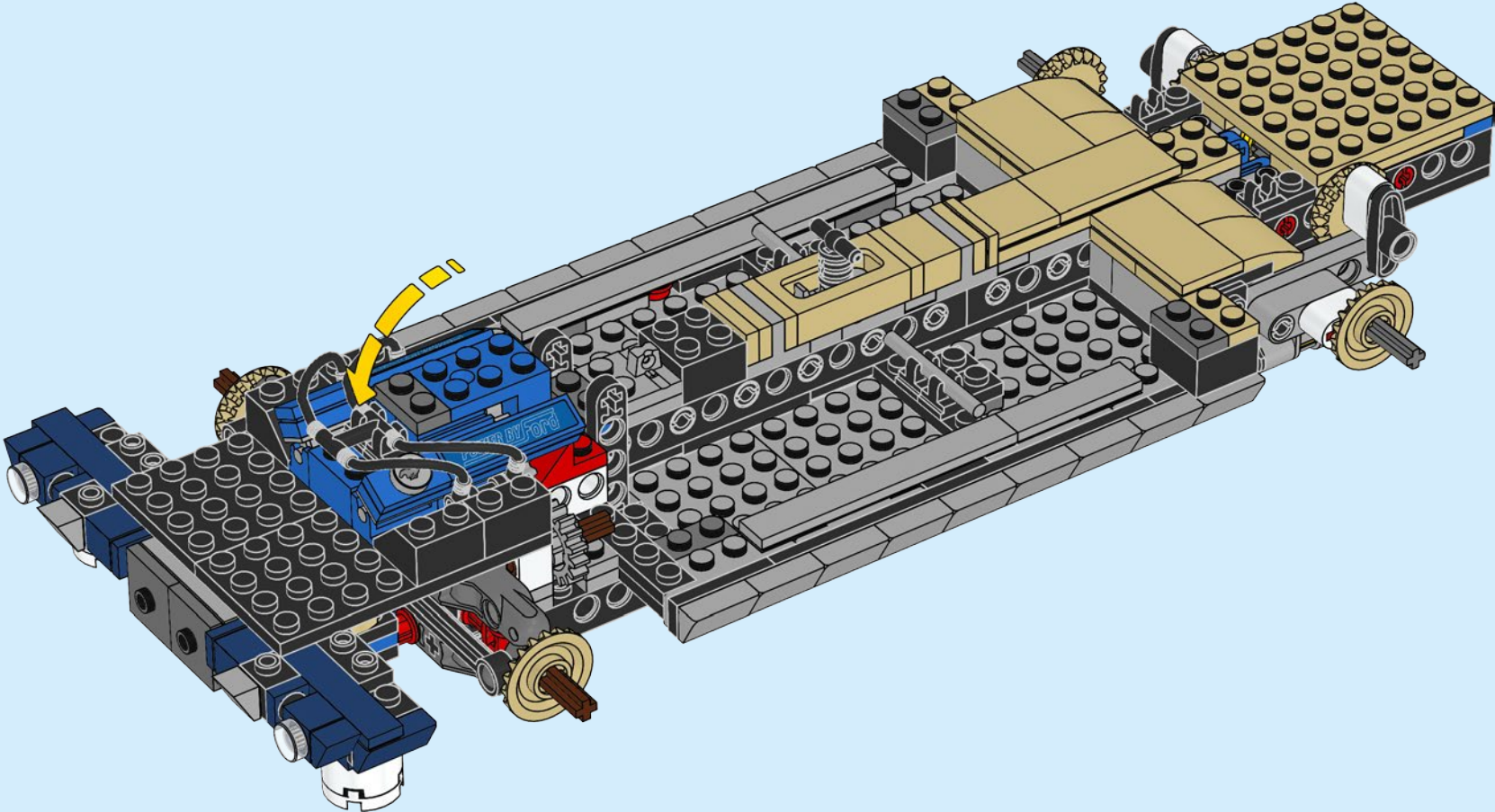

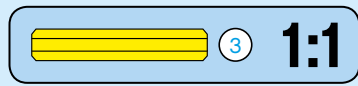
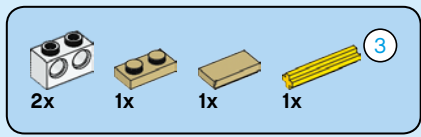

92

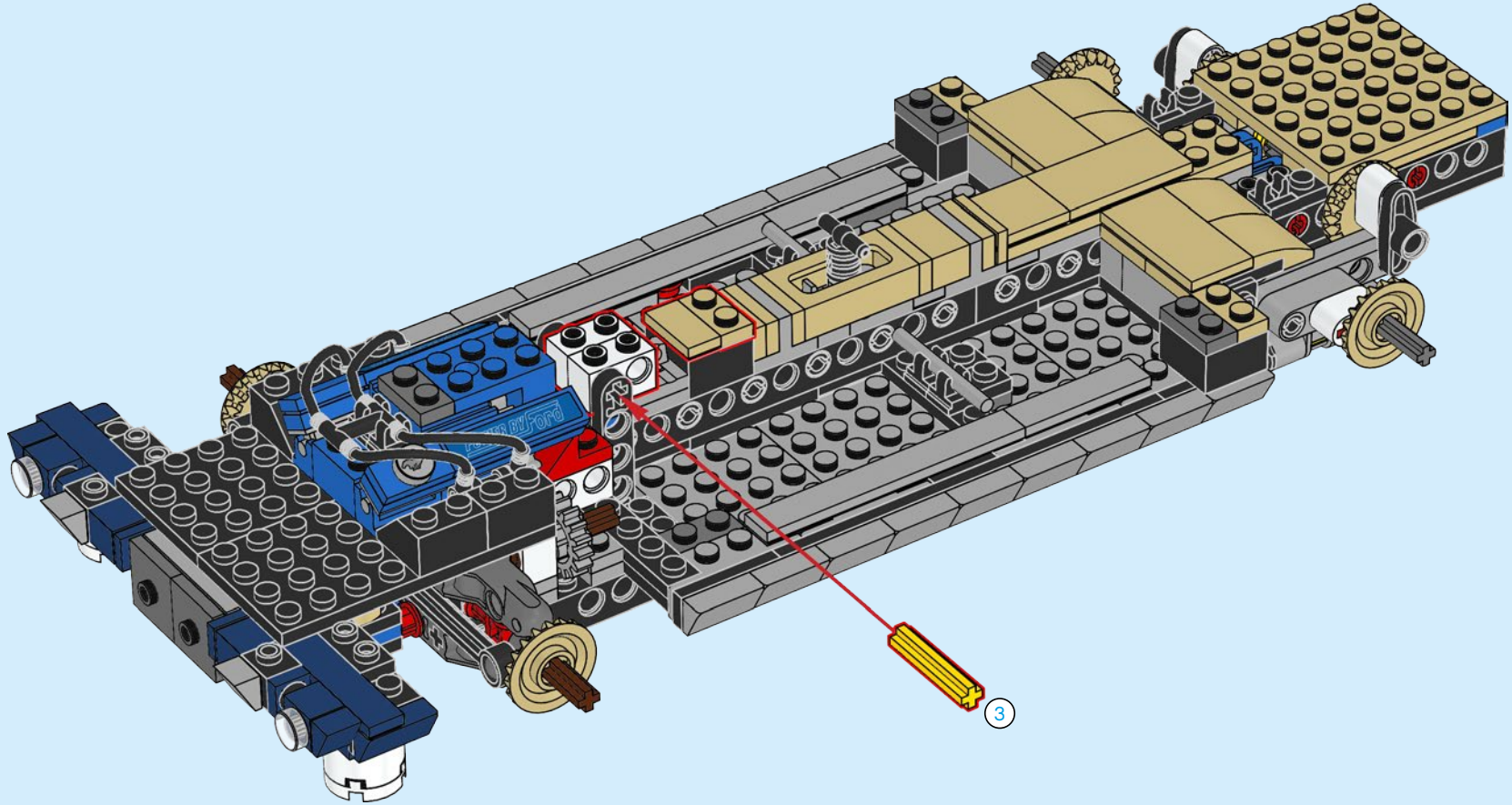

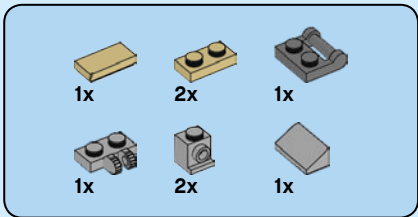

93

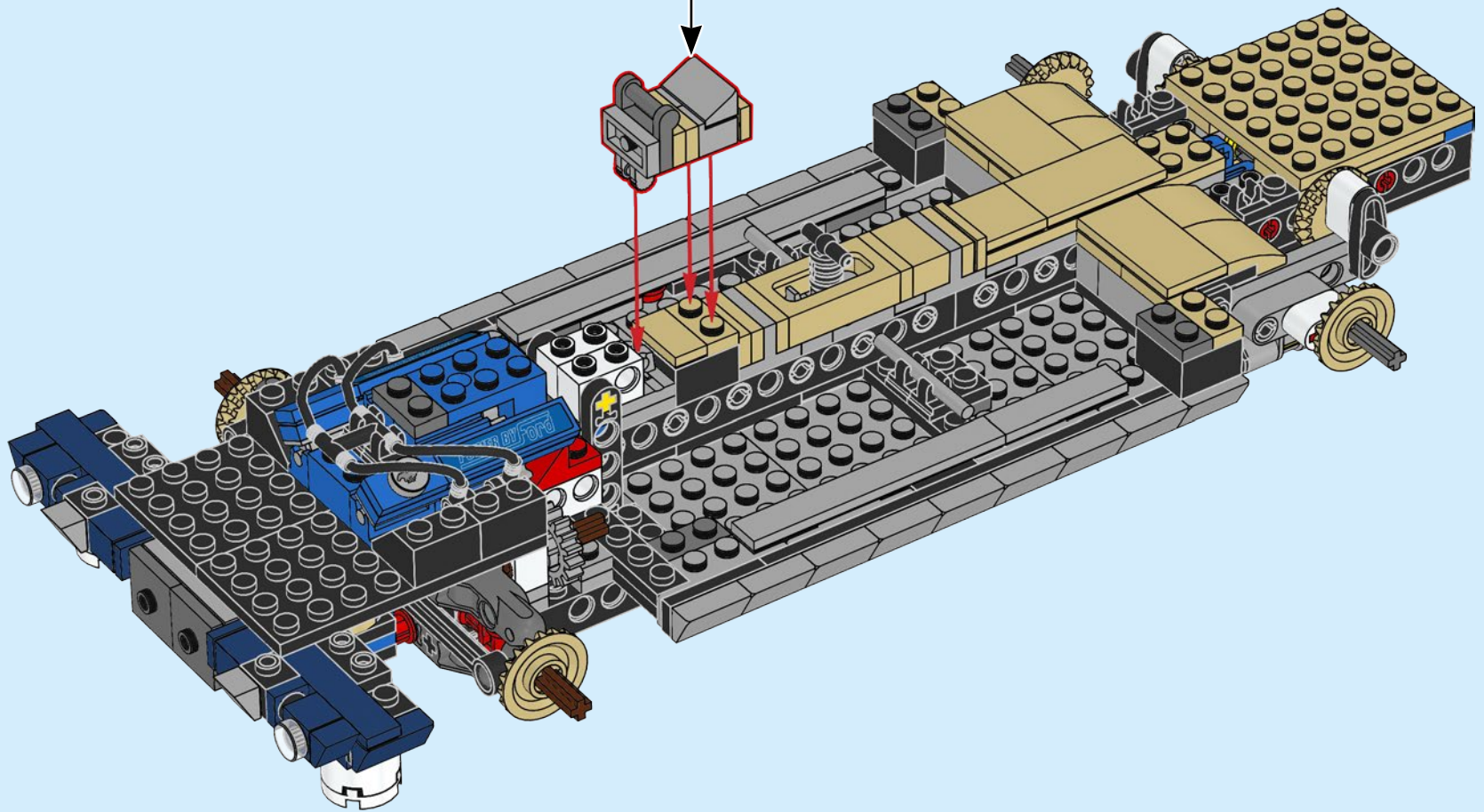
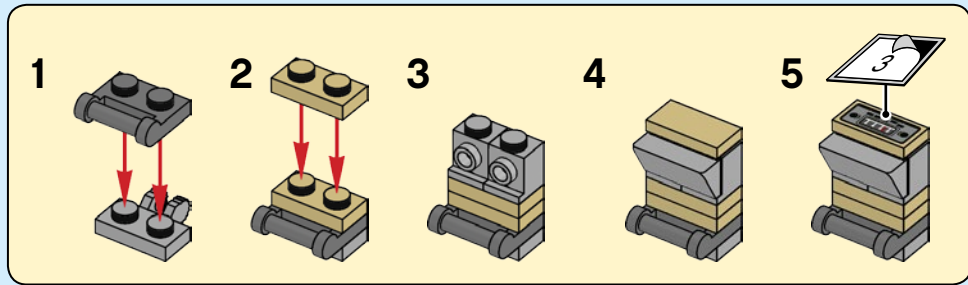

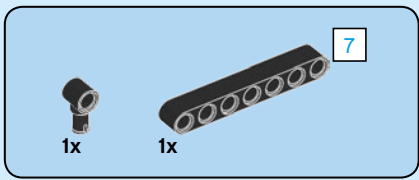

94

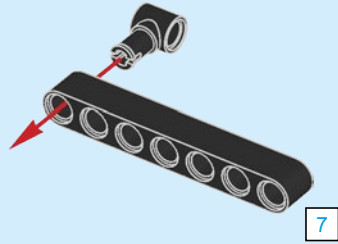

95

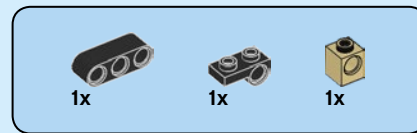
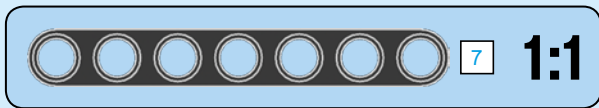
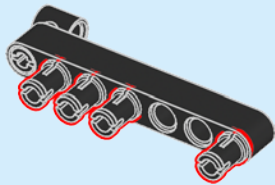

96

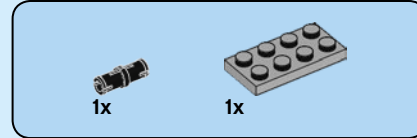
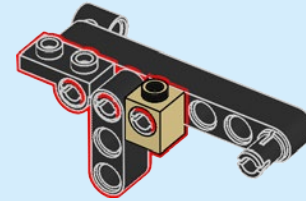

97

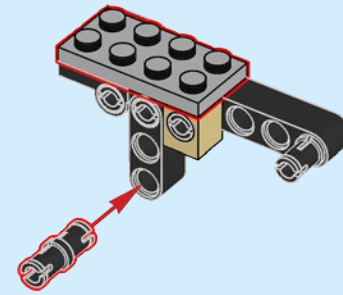

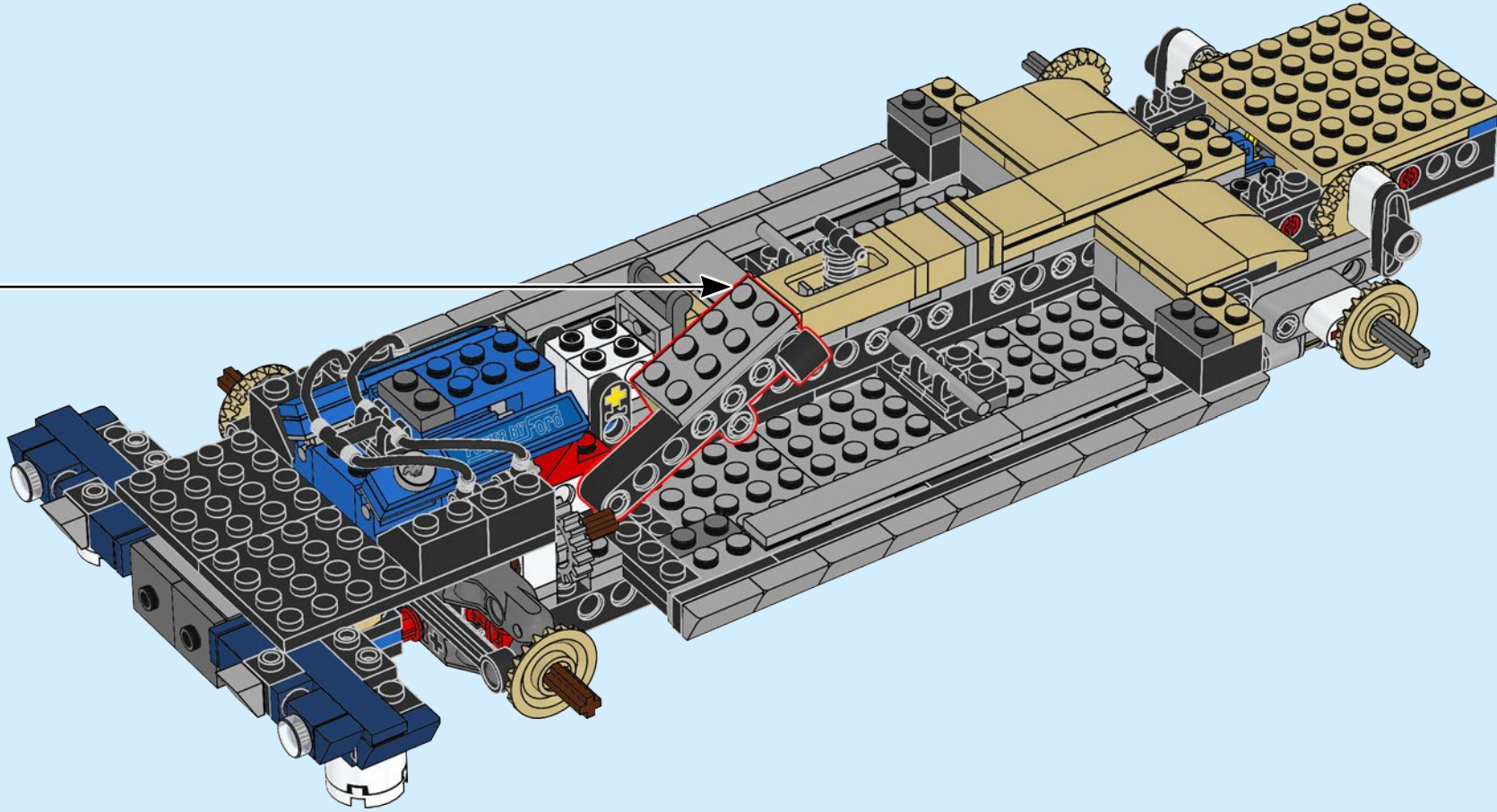

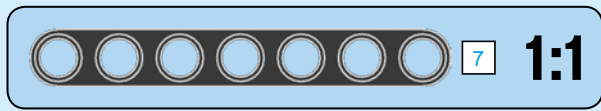
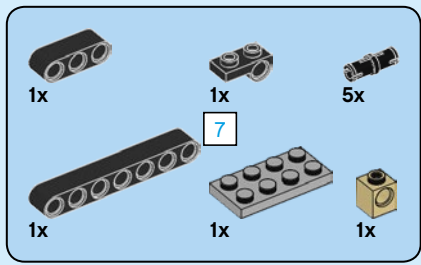

99

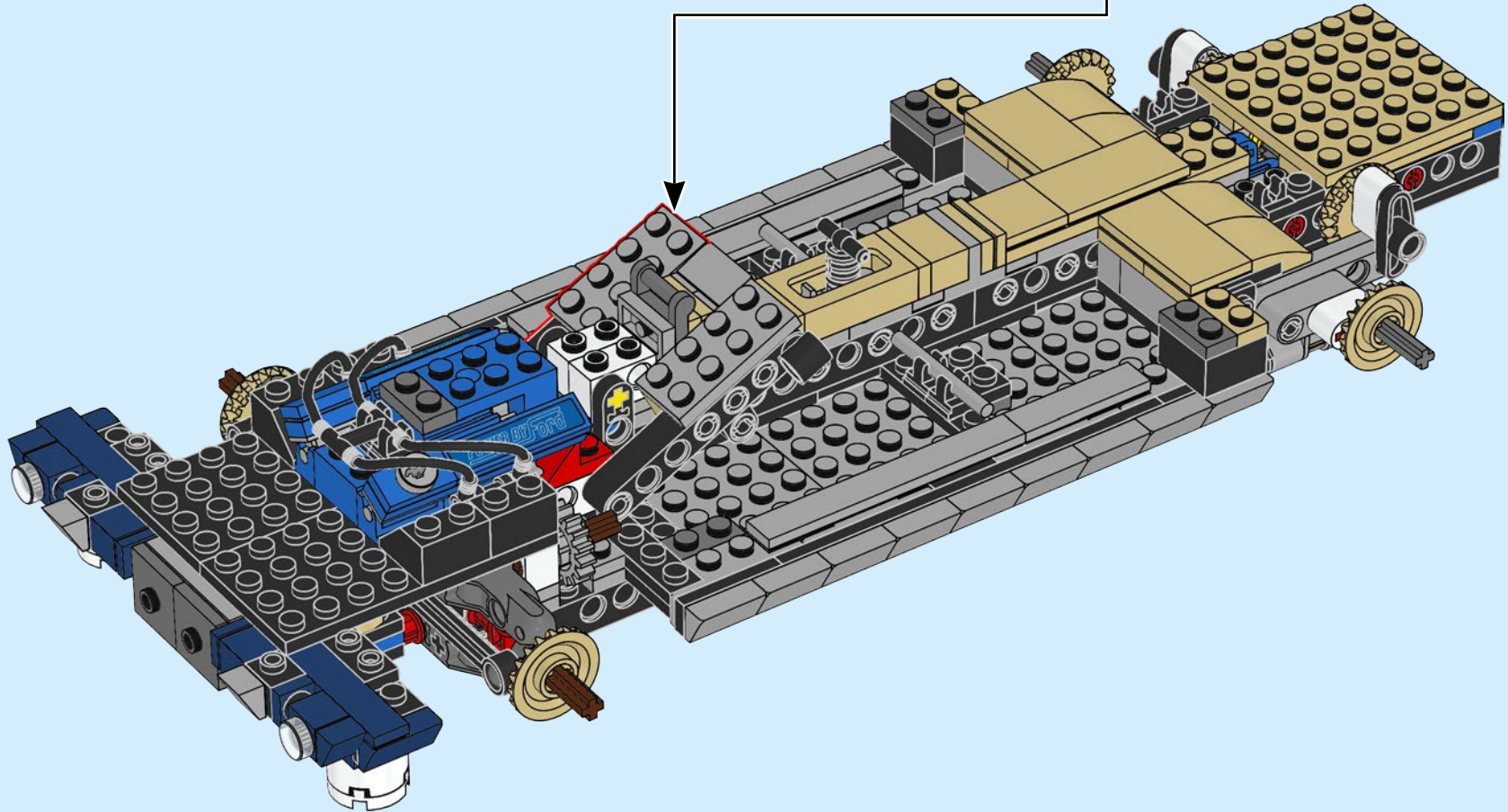
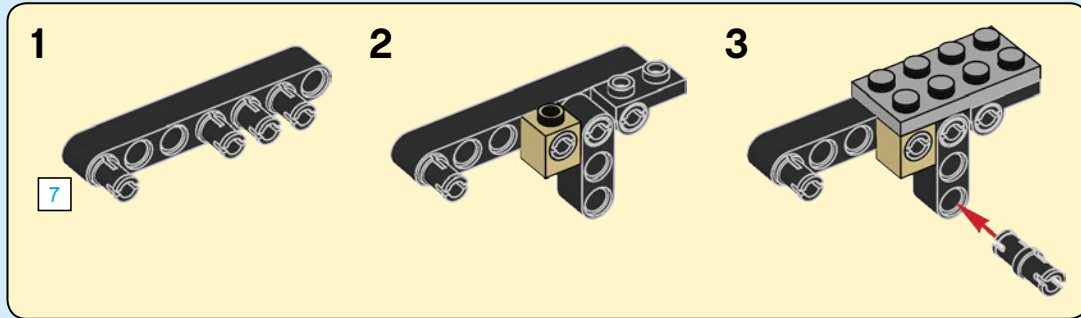

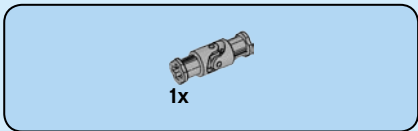

100

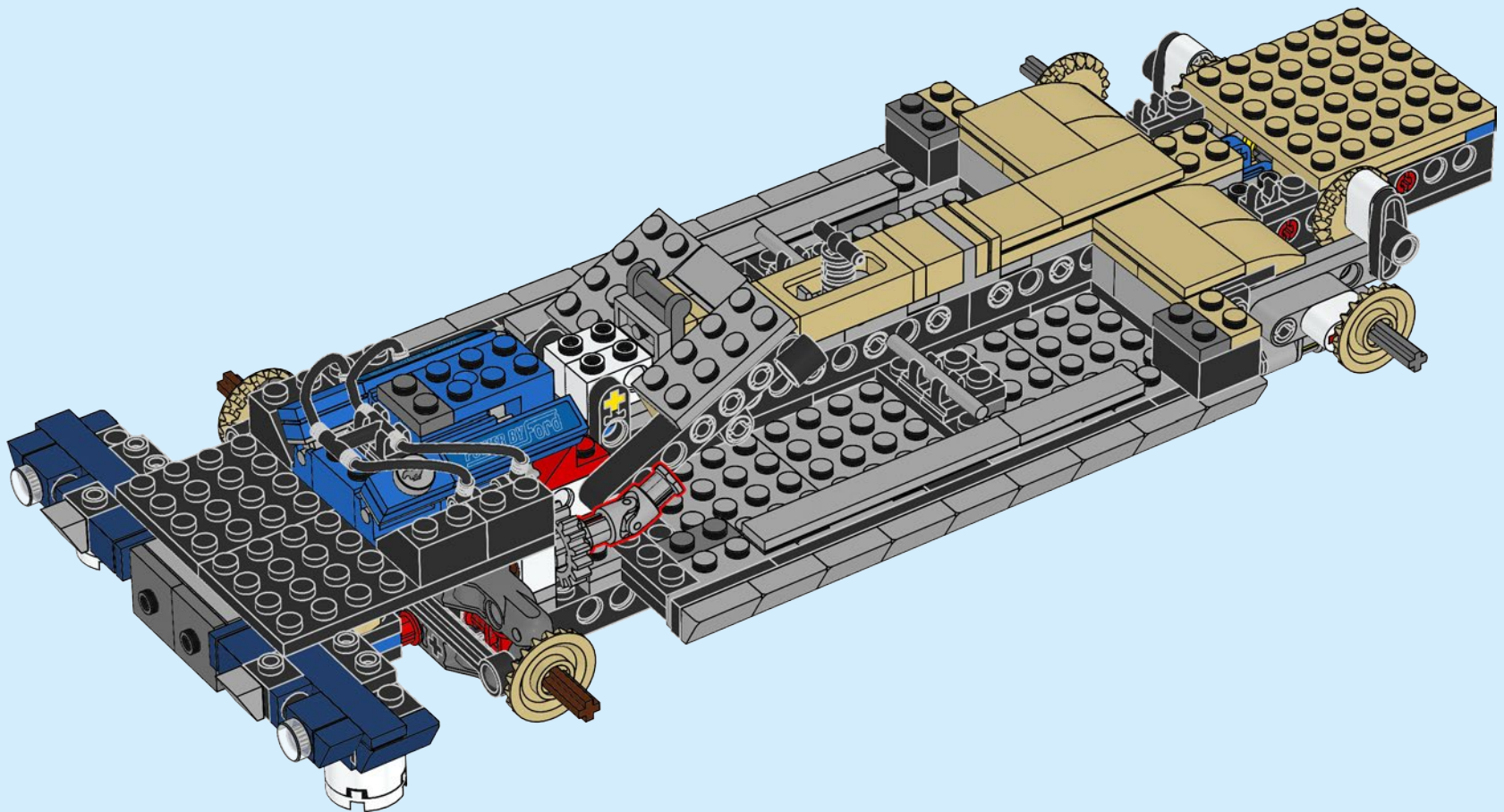

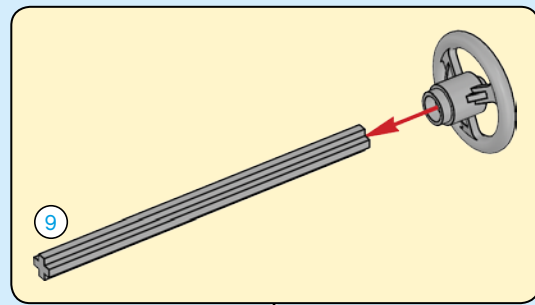
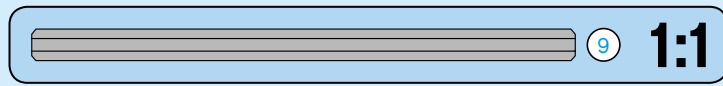
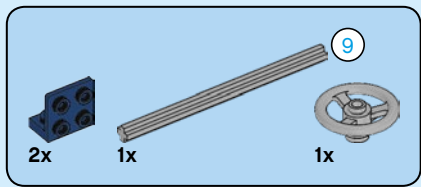

101

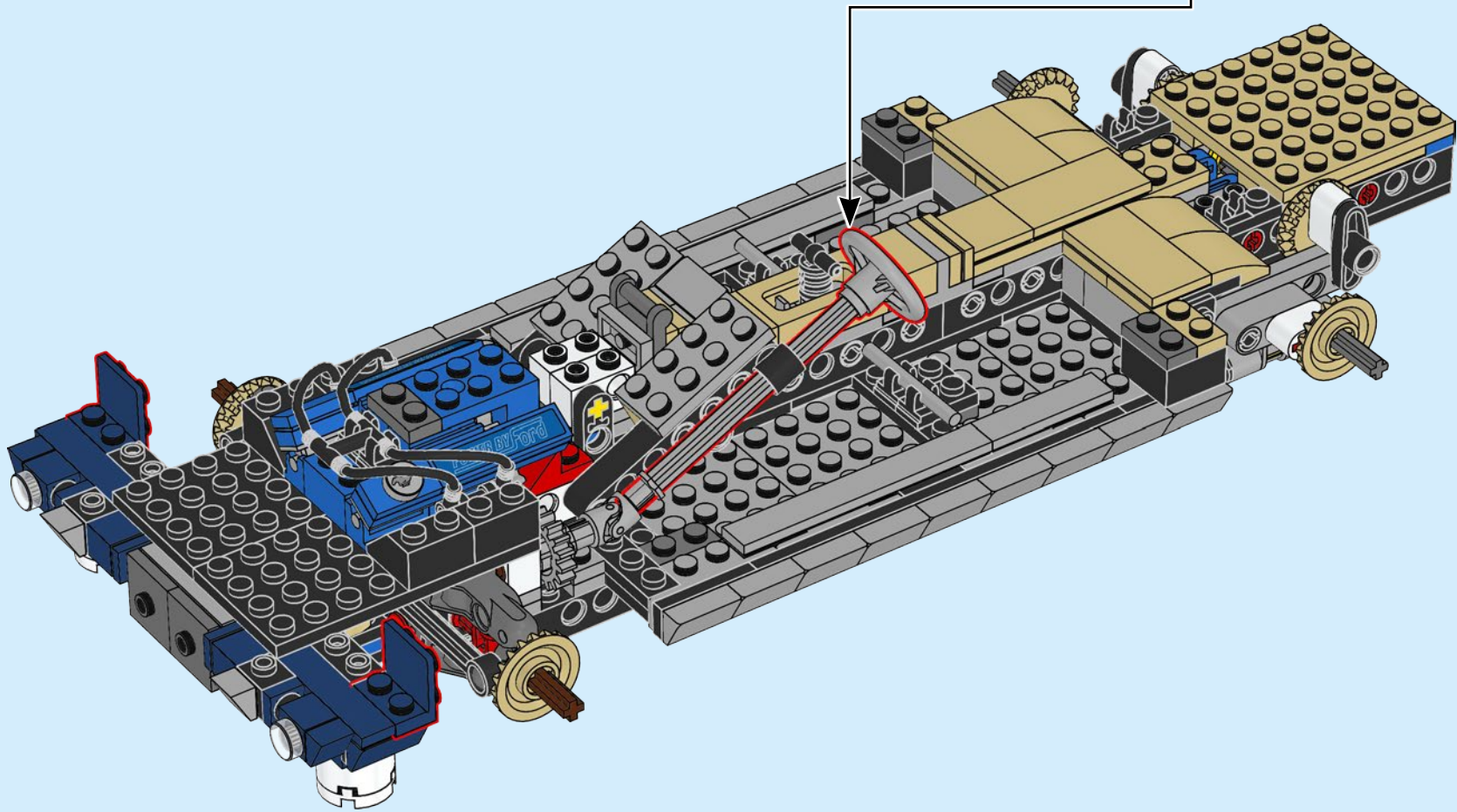

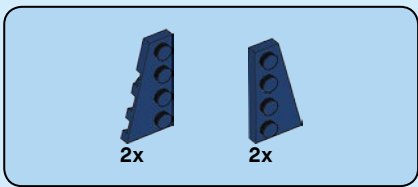

102

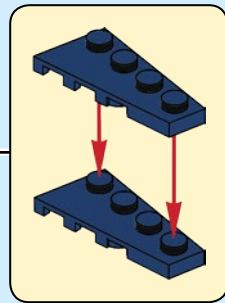
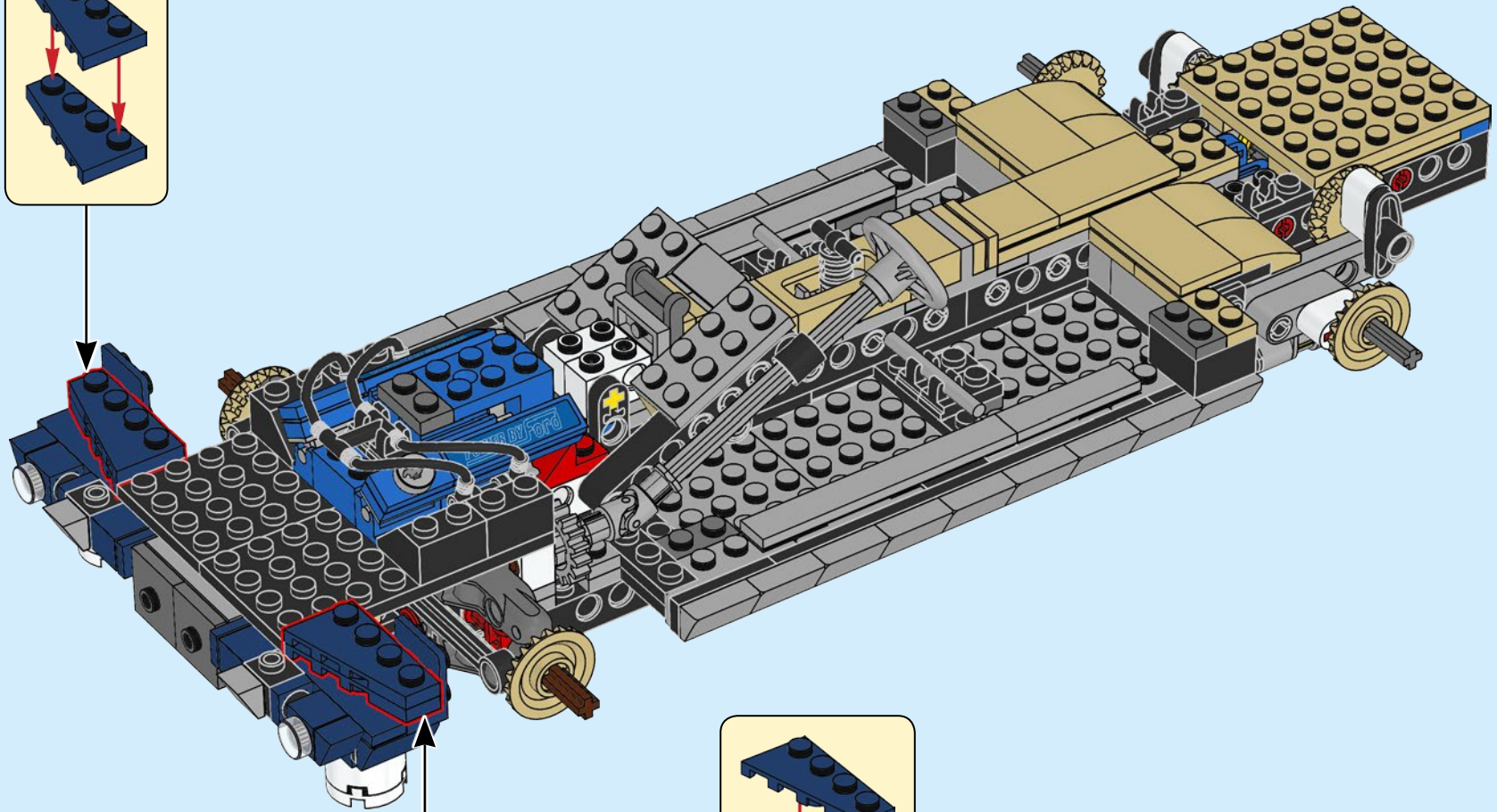
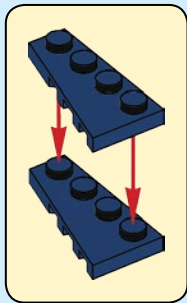

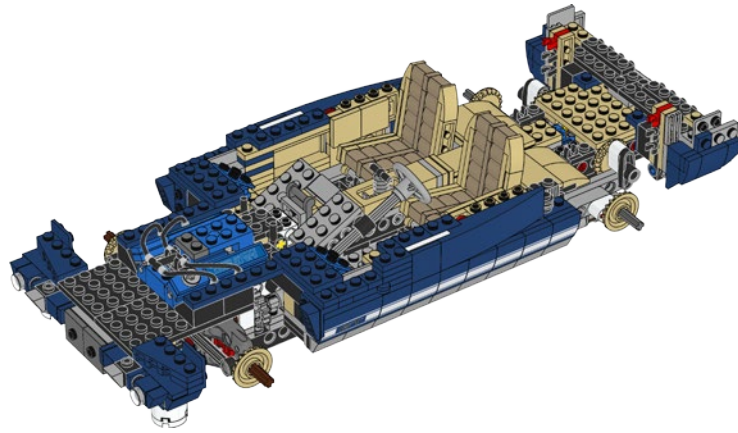
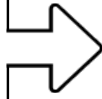
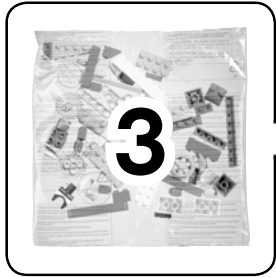

1x



2x

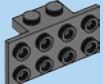

2x

103

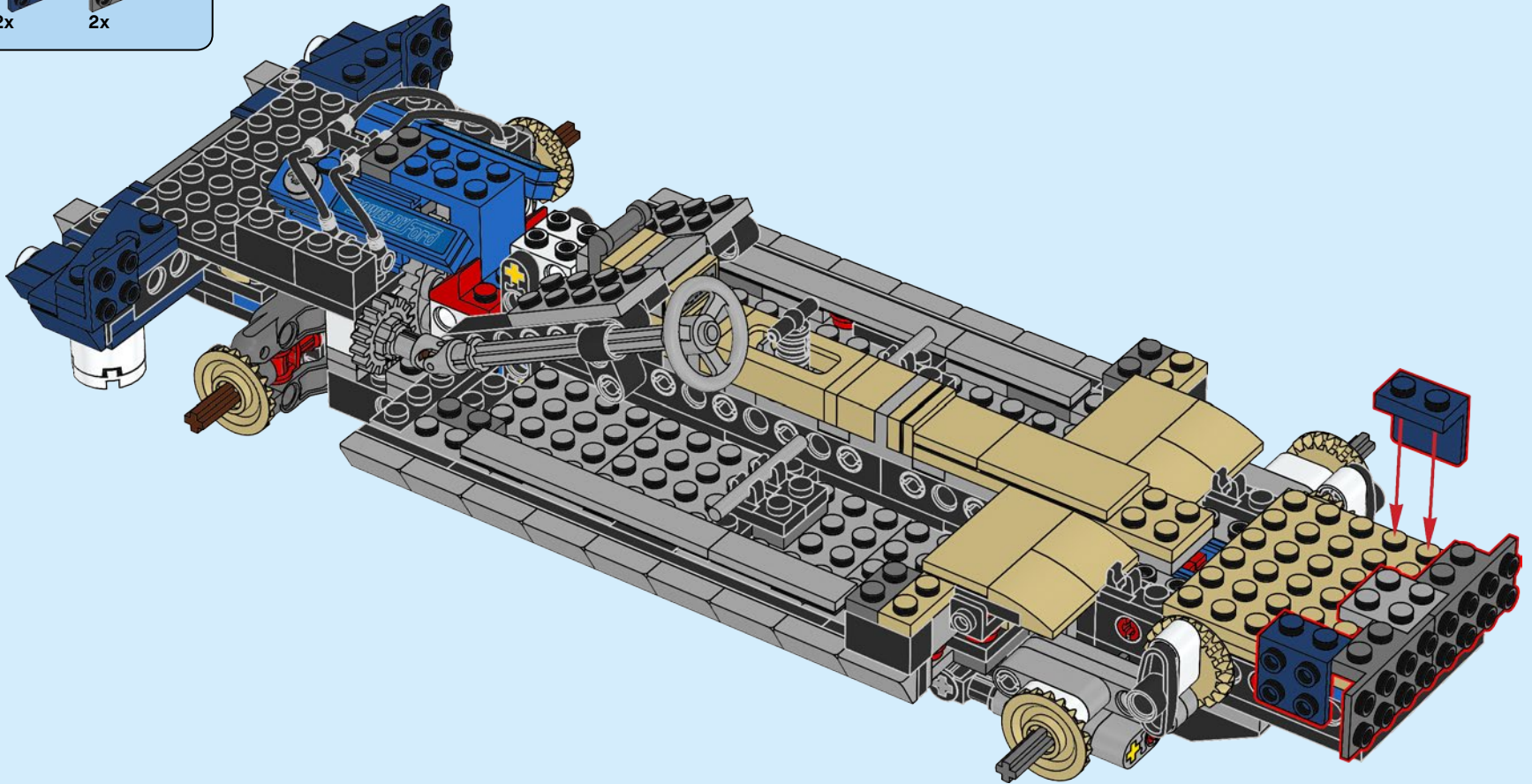

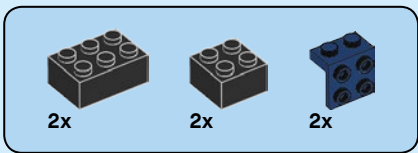

104

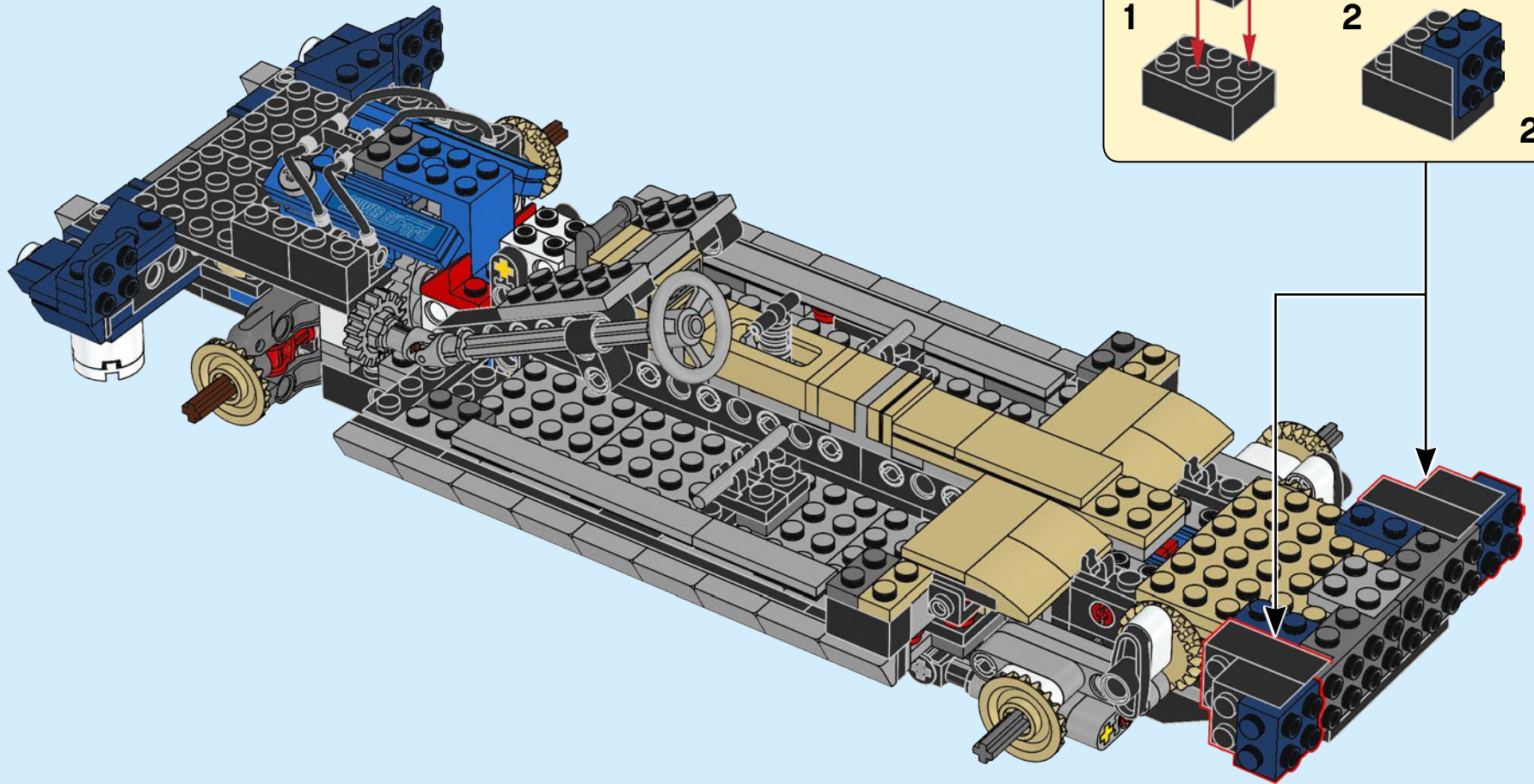
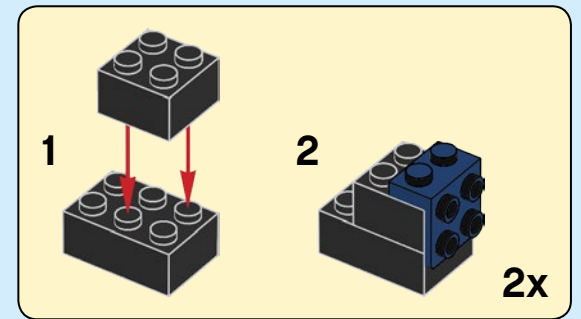

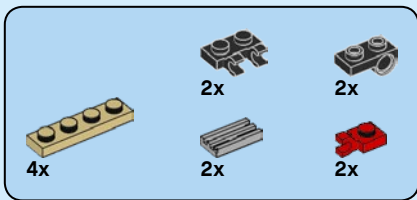

105

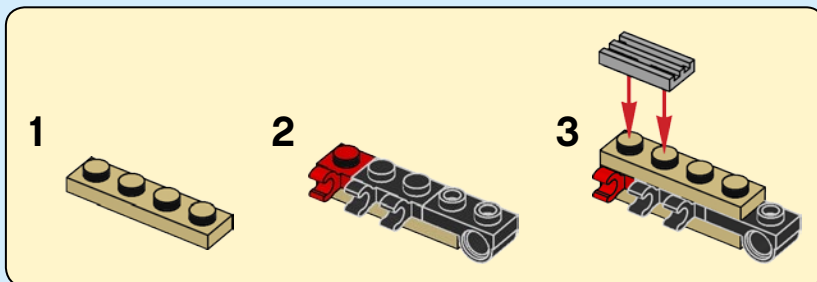
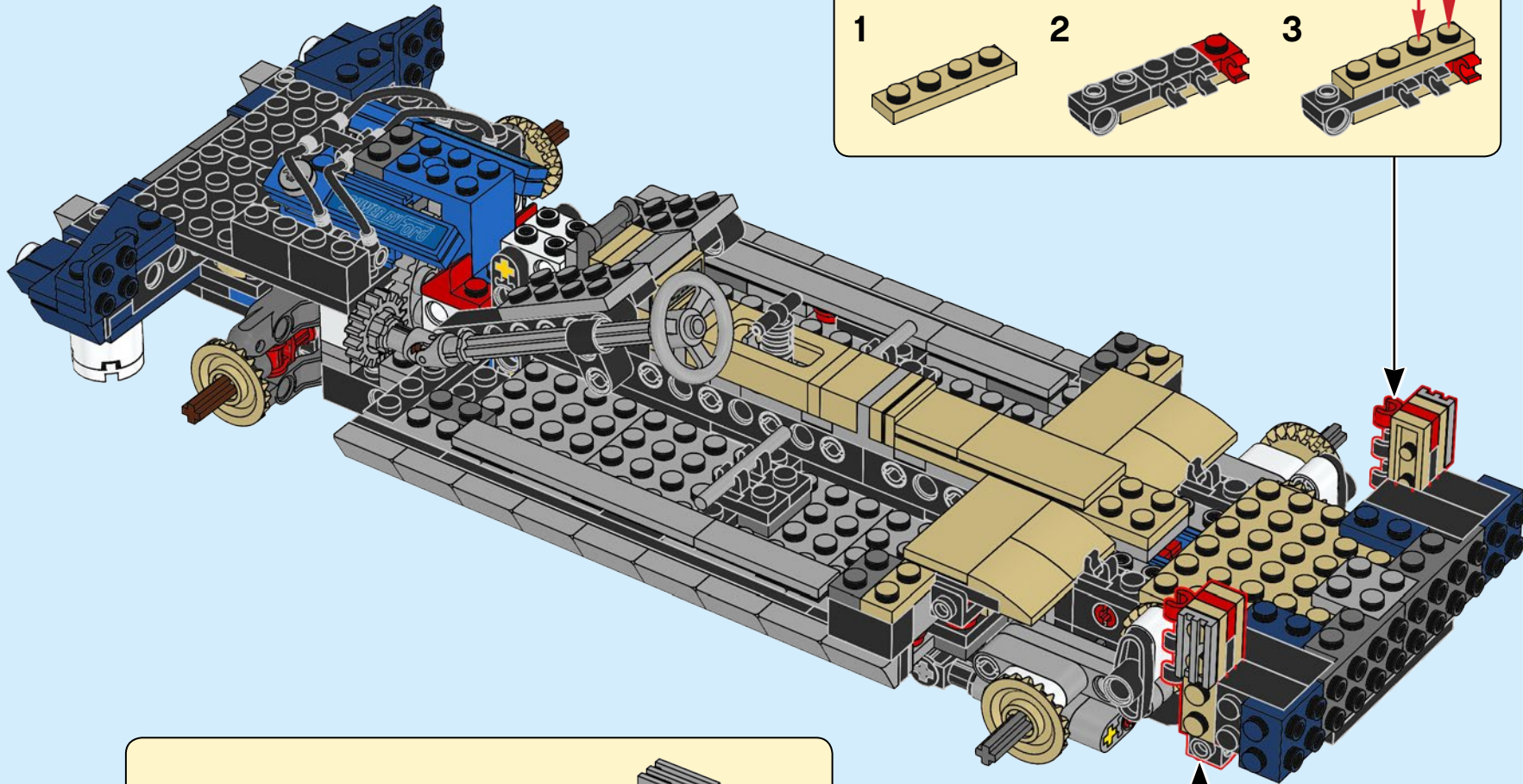
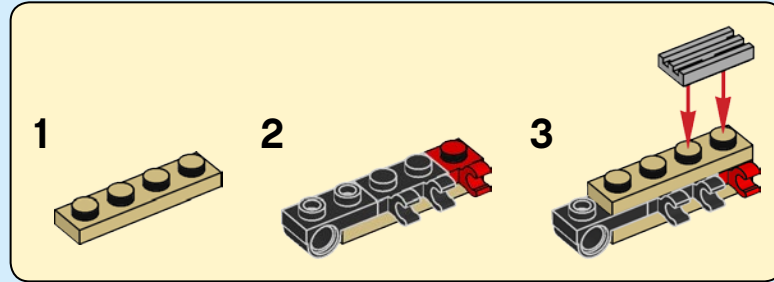

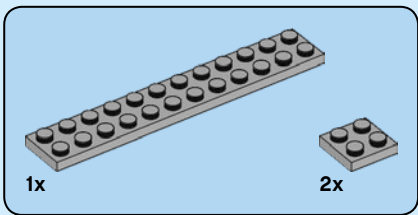

106

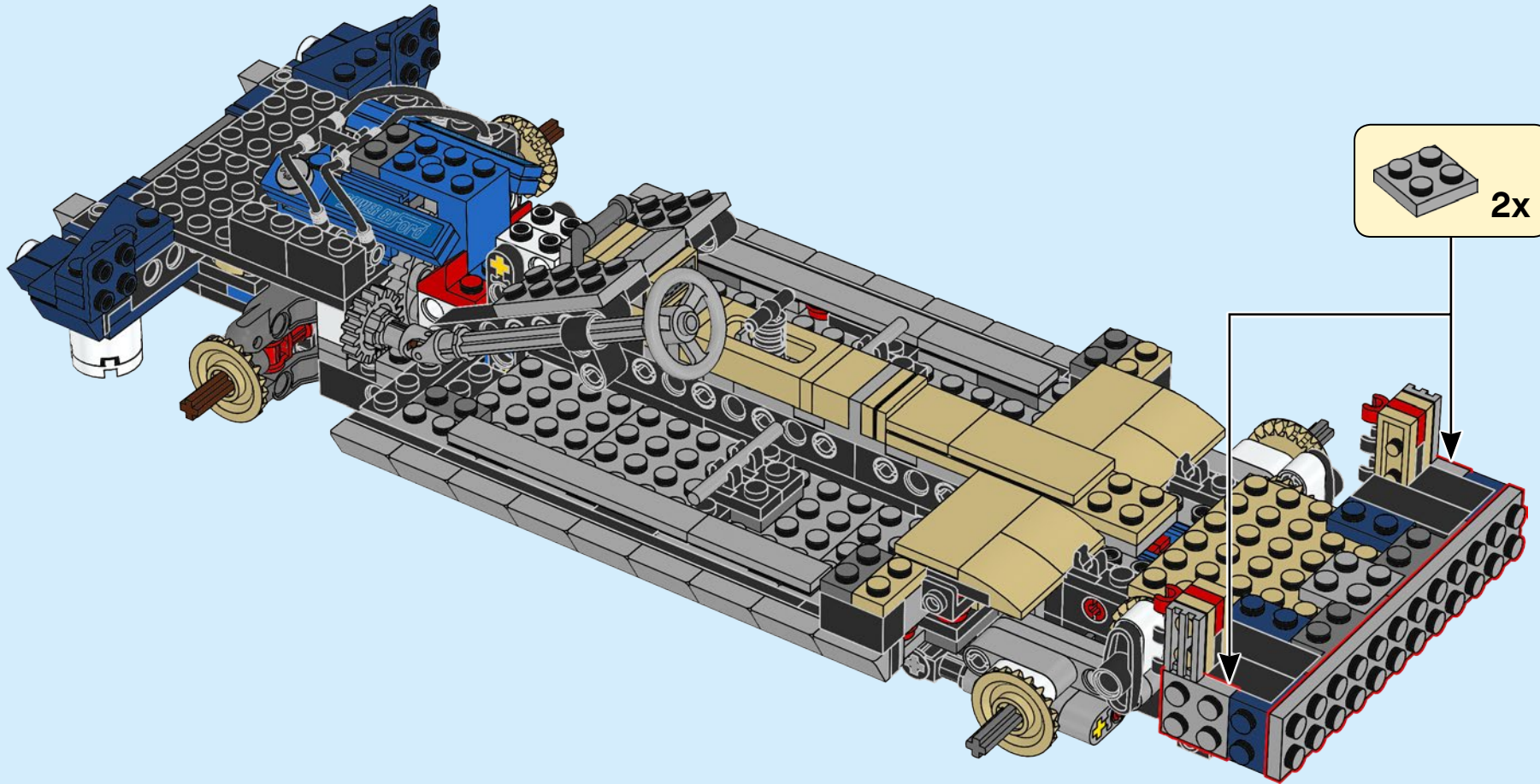

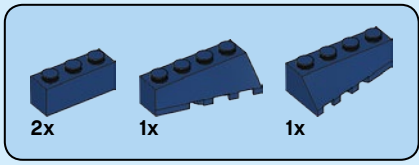

107

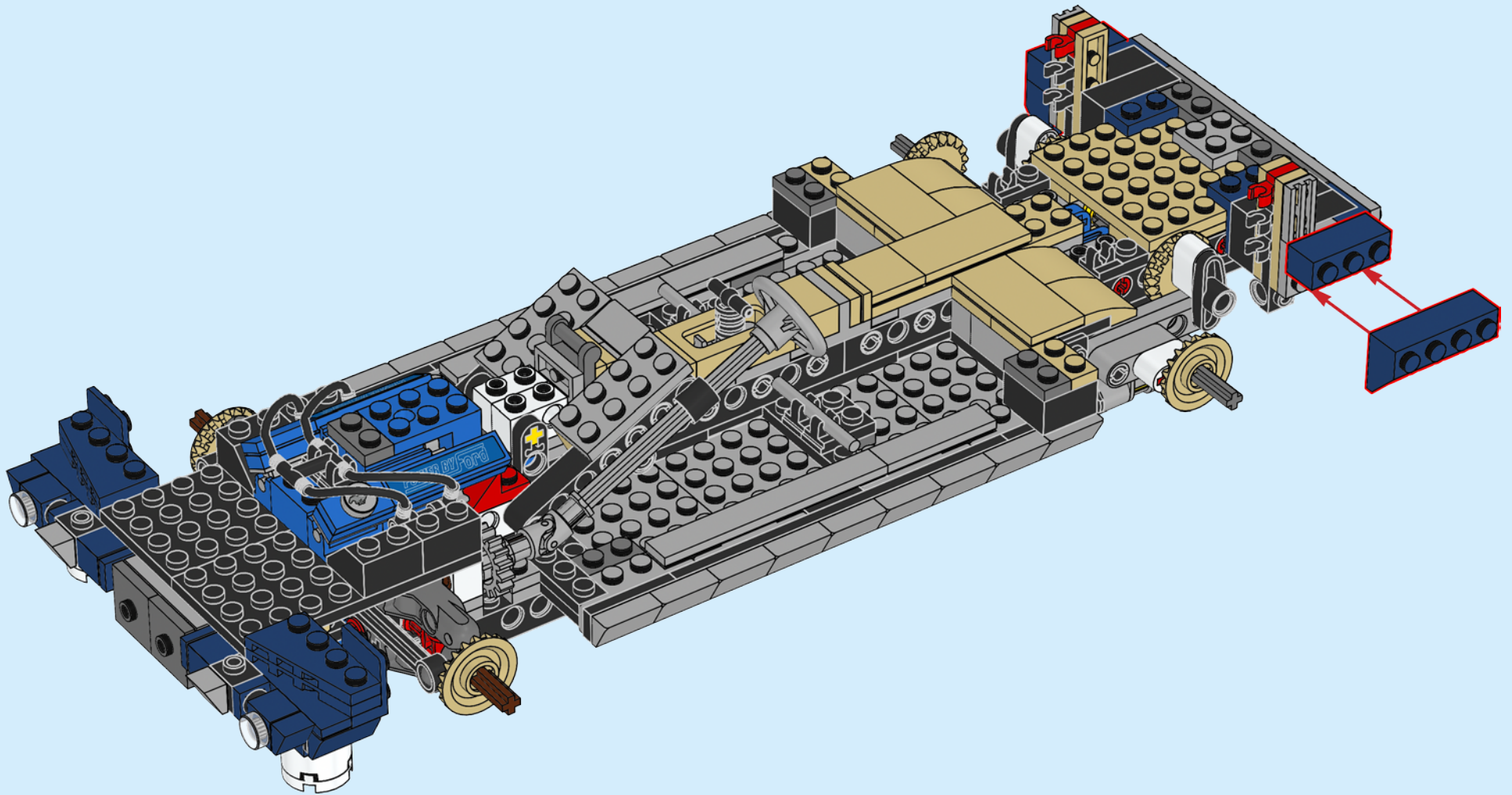

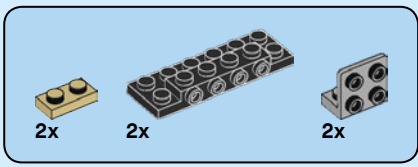

108

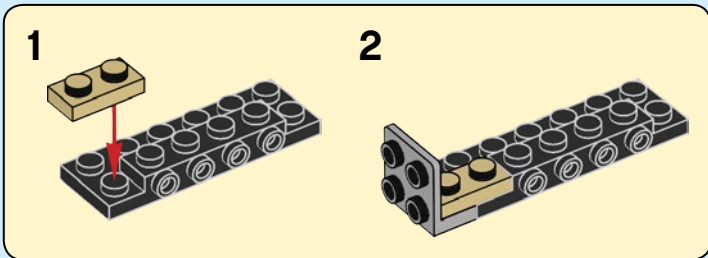
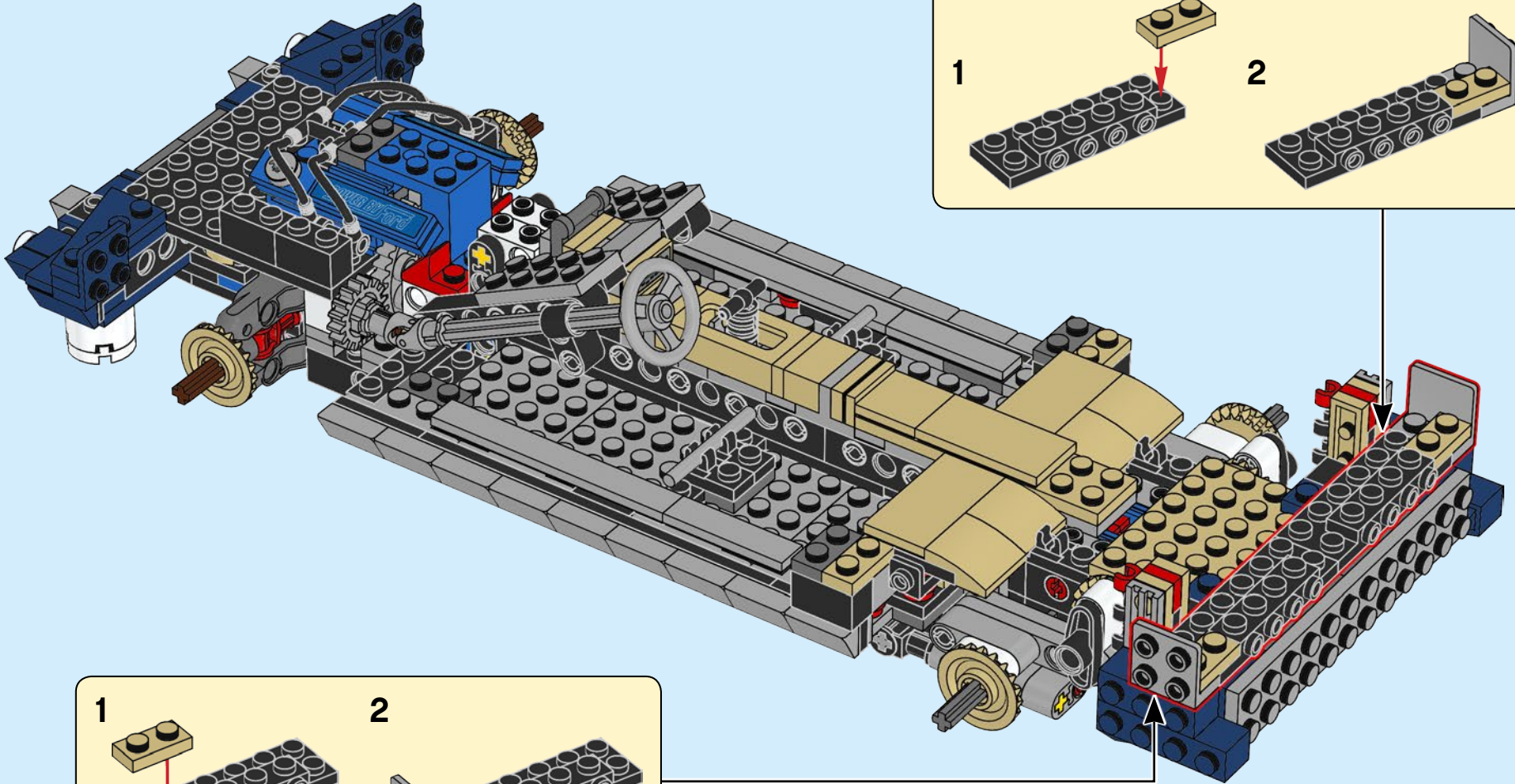
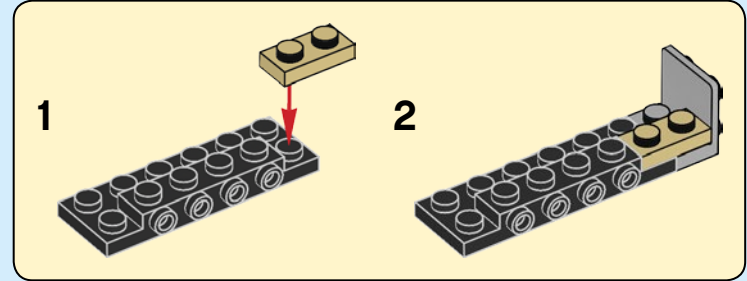

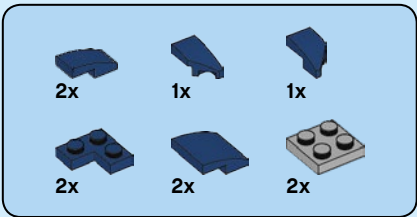

109

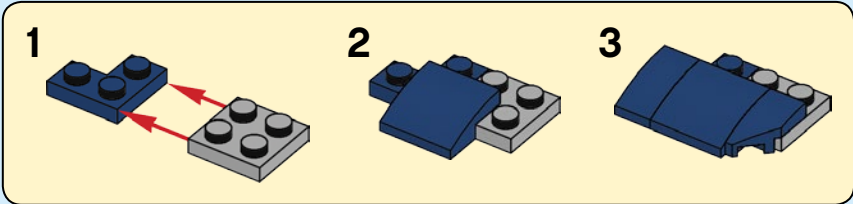
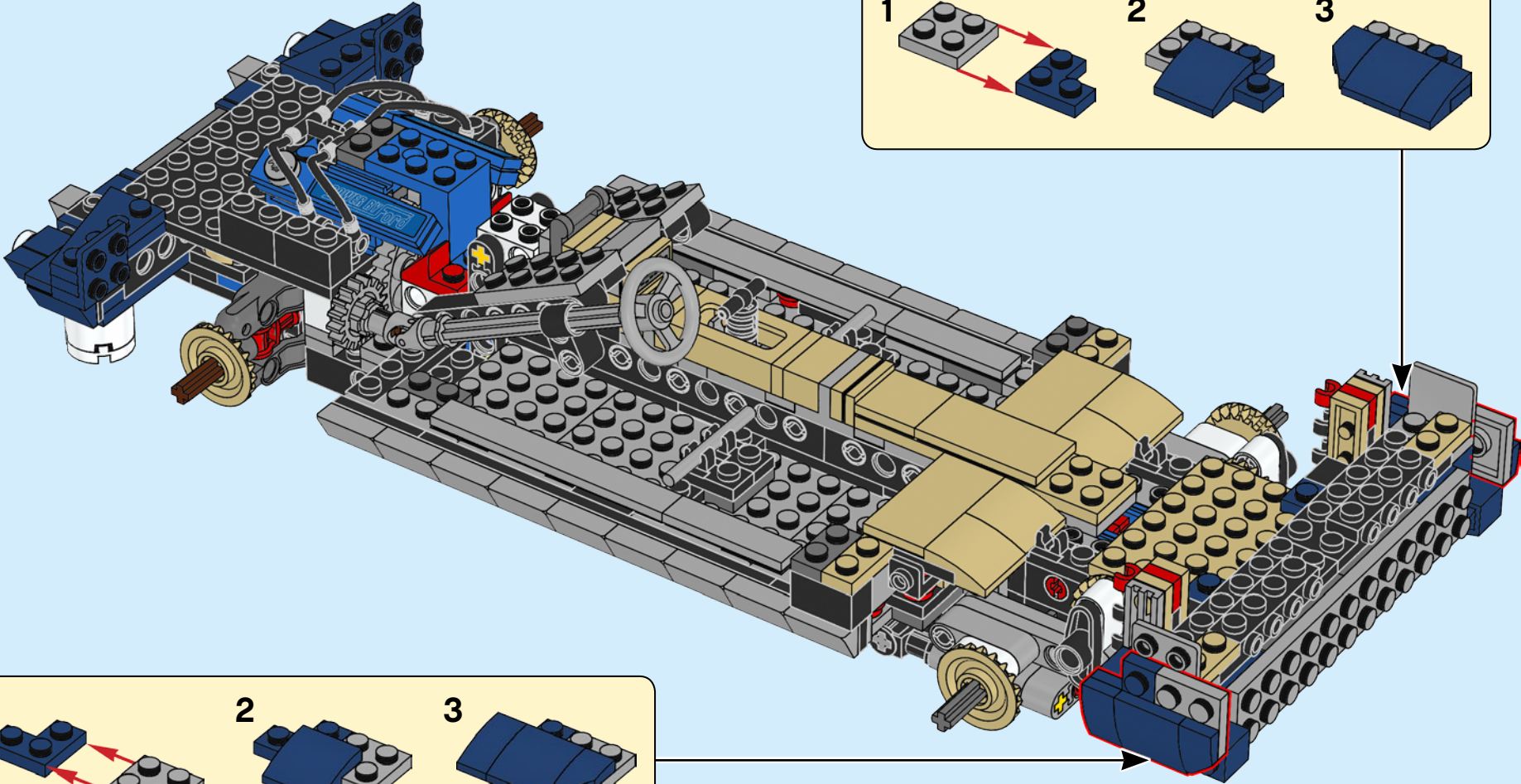
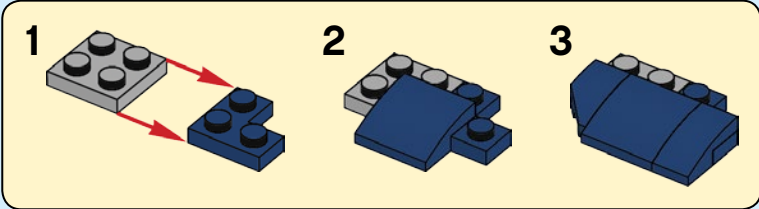

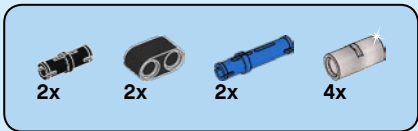

110

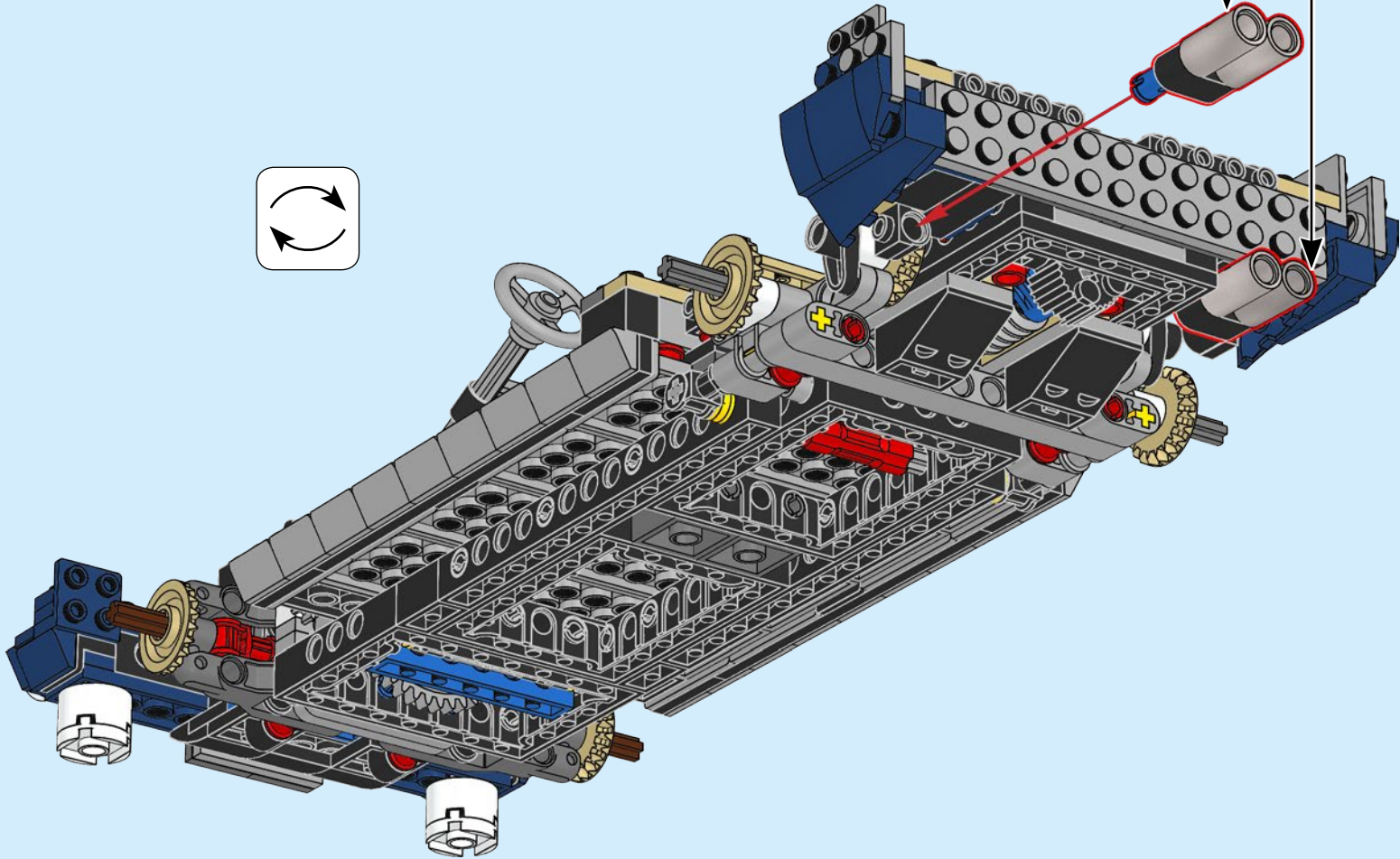
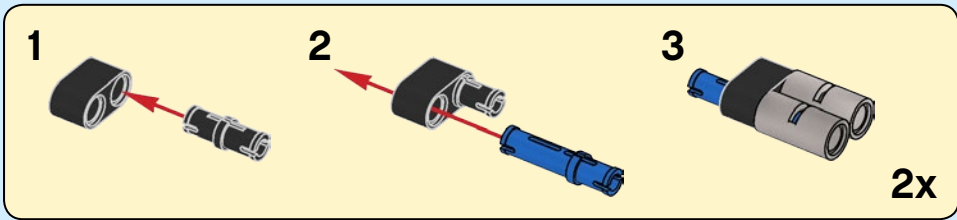

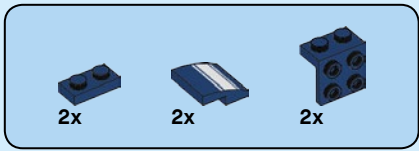

111

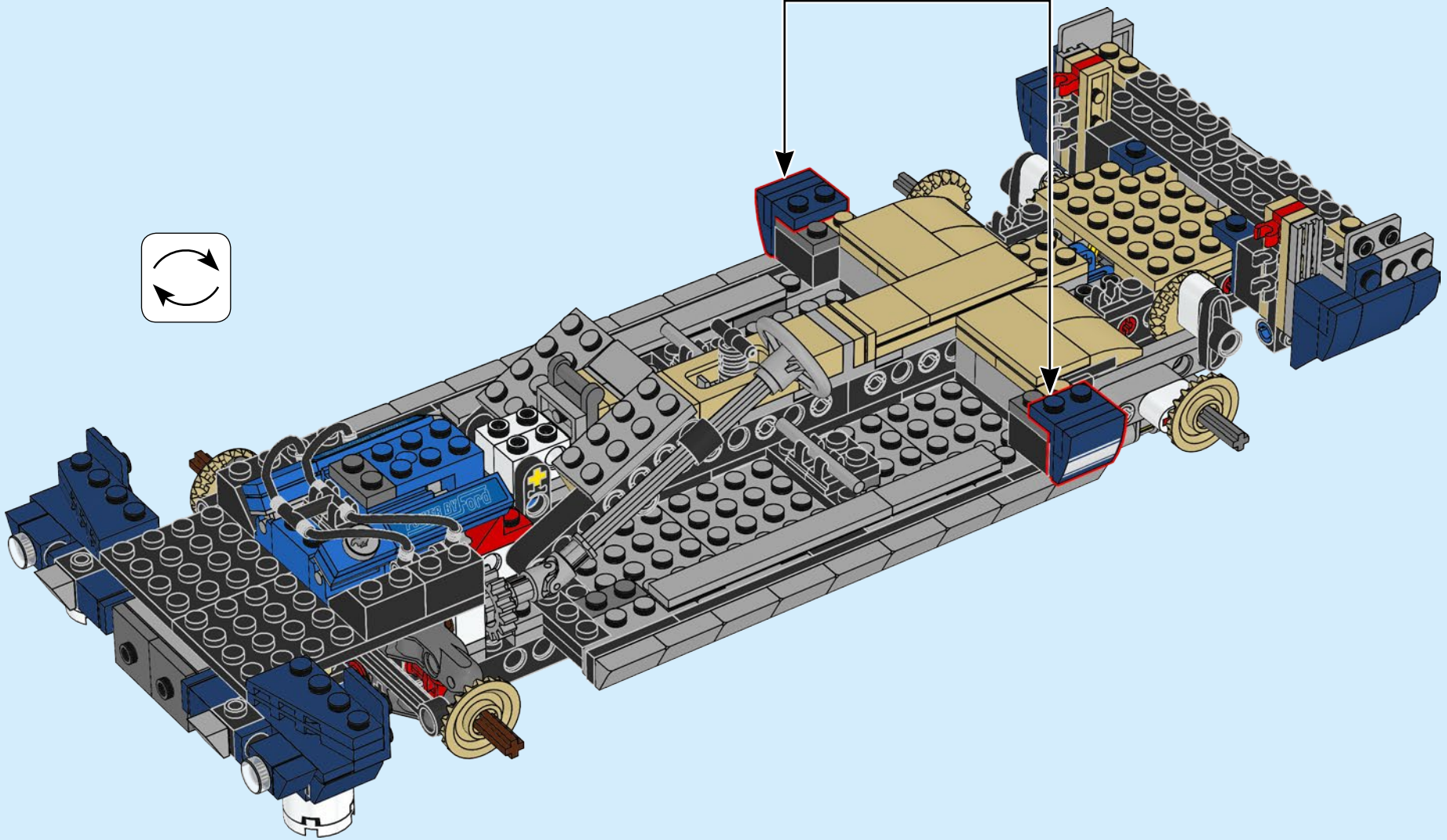
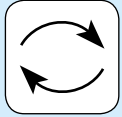
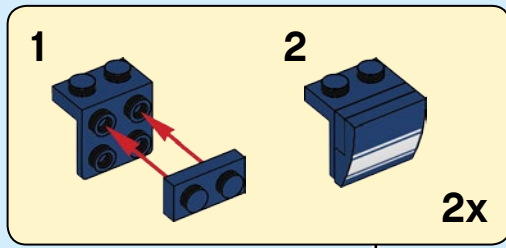

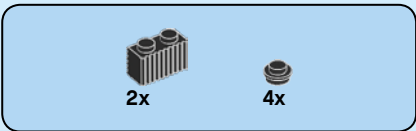

112

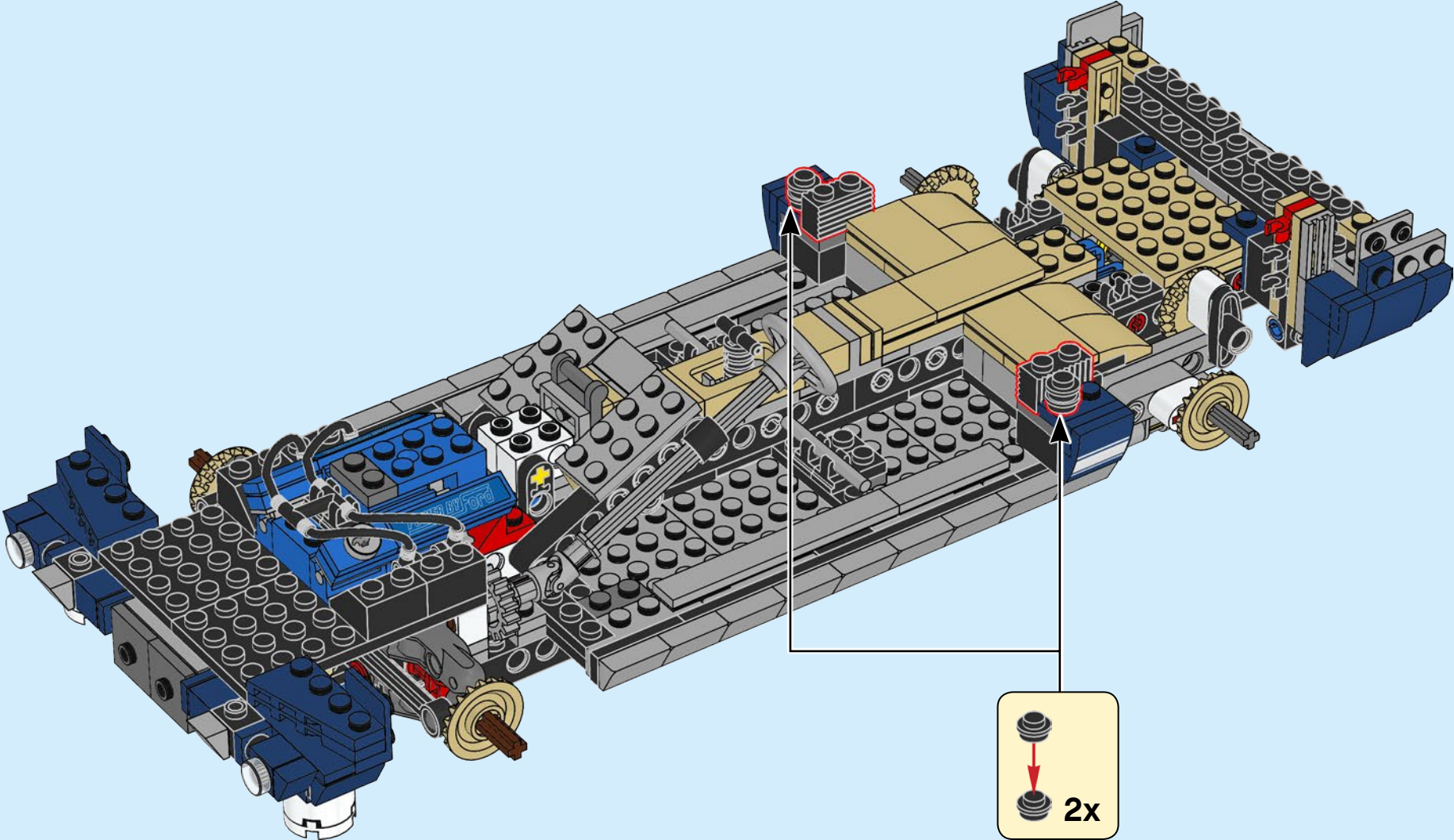

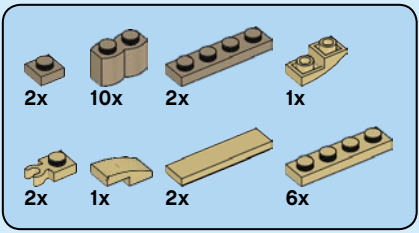

113

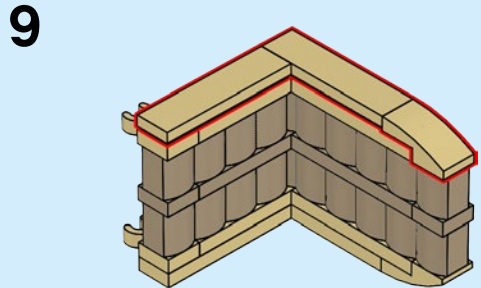
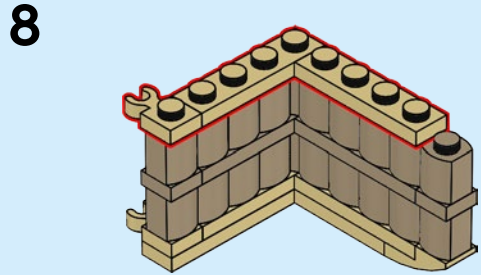
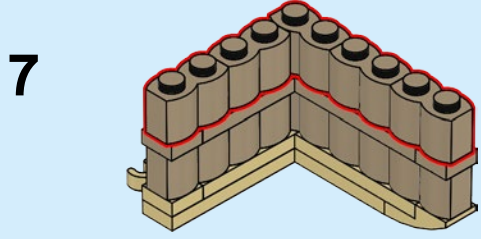
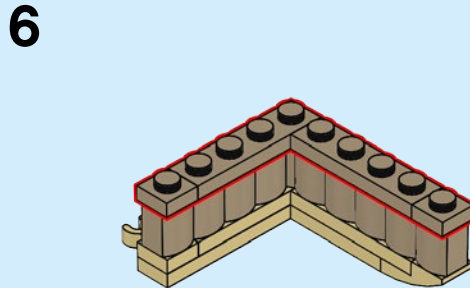
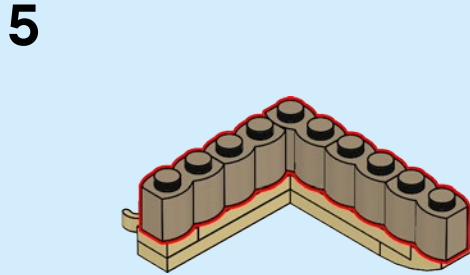
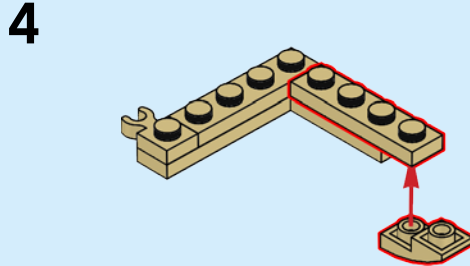
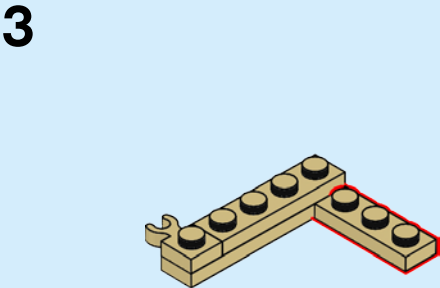
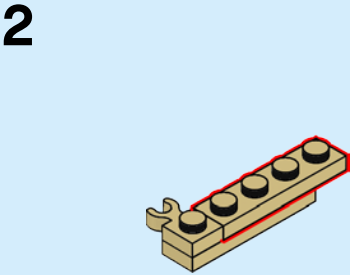
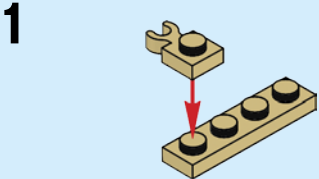

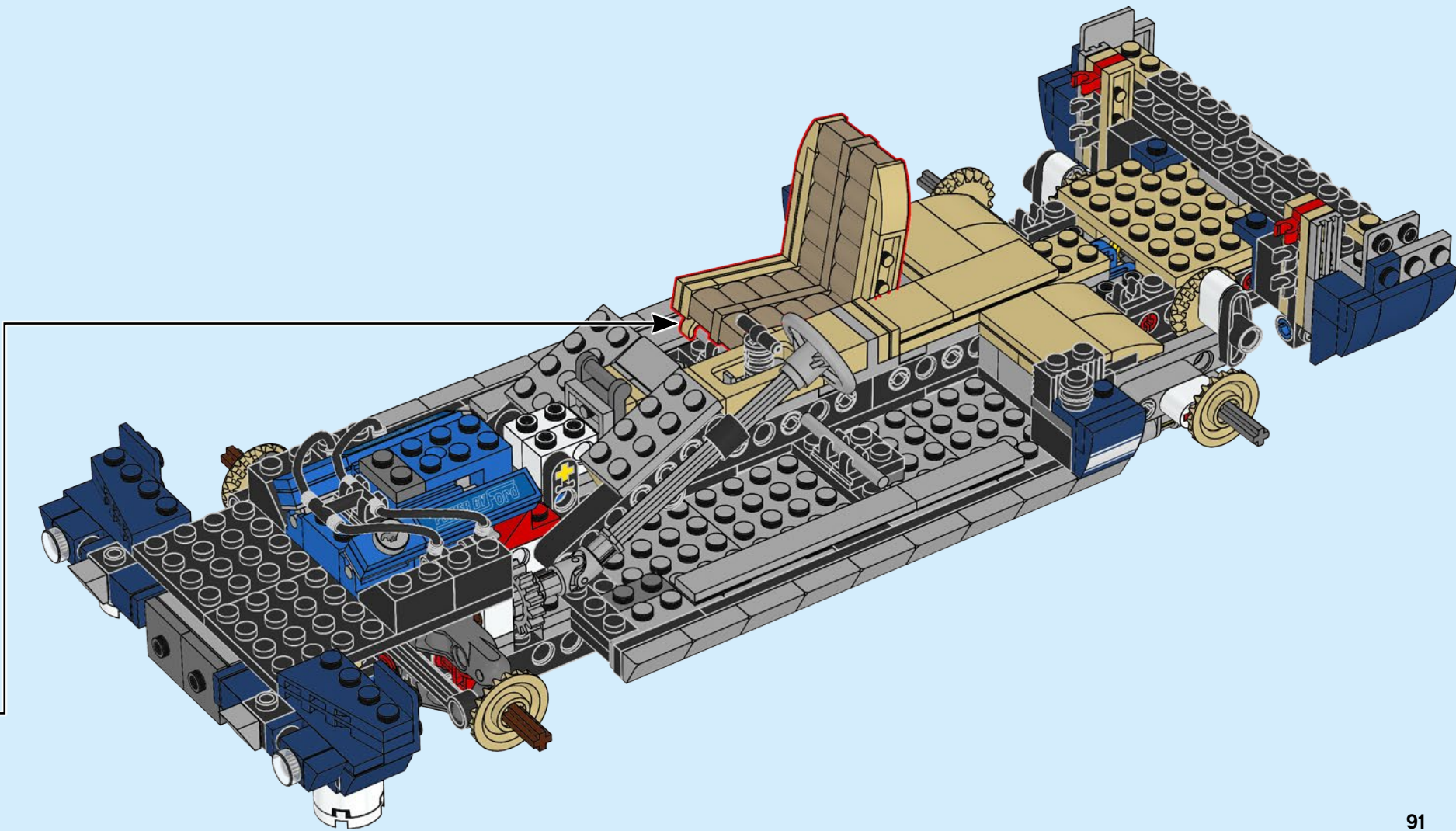

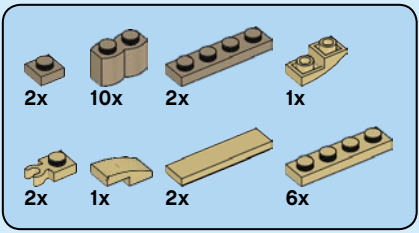

114

1

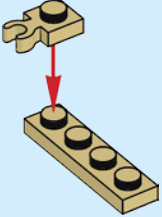

2

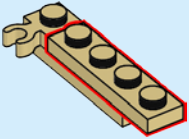

3

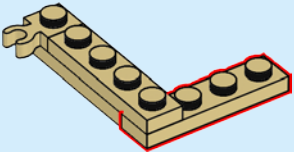

4

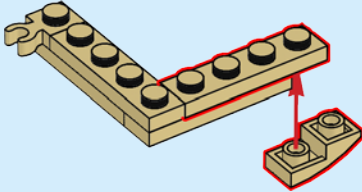

5

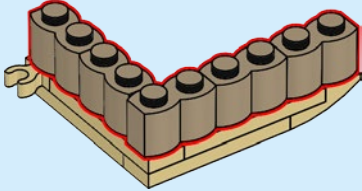

6

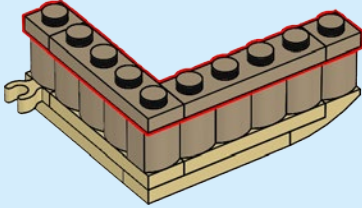

7

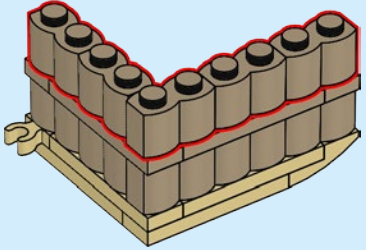

8

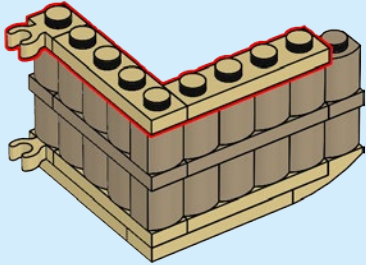

9

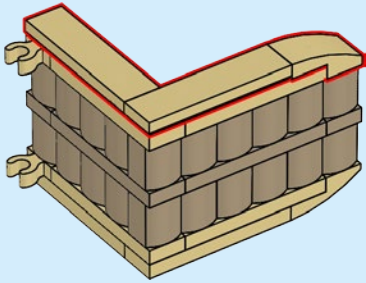

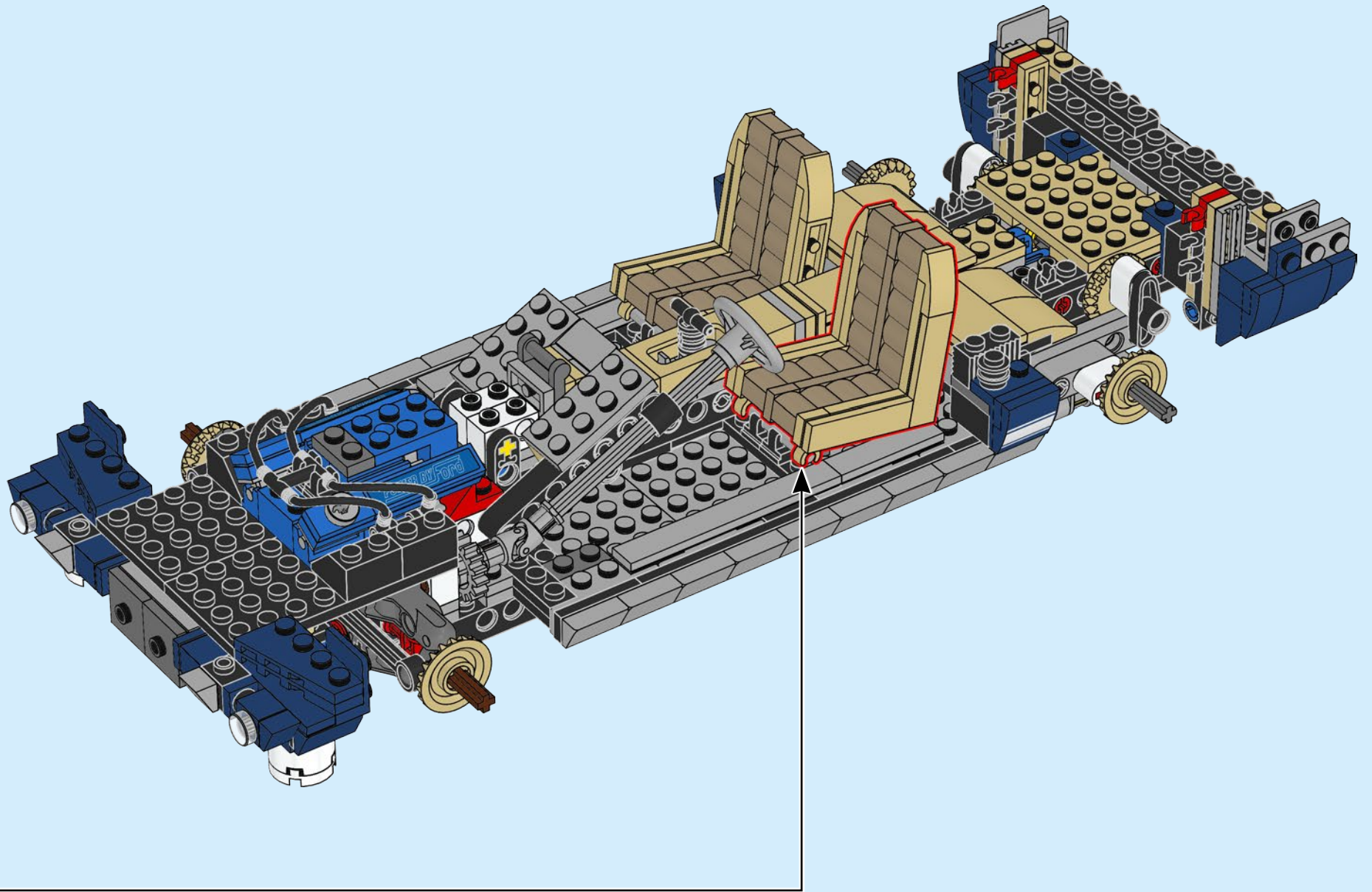

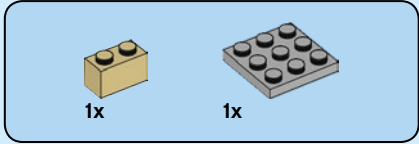
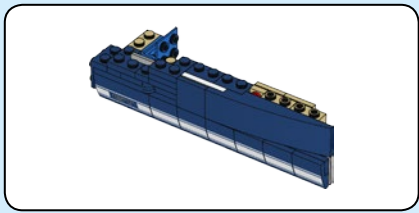

115

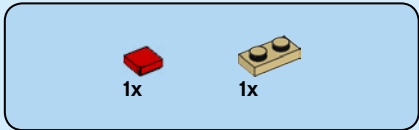
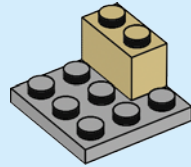

116

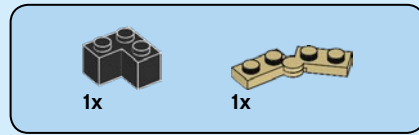
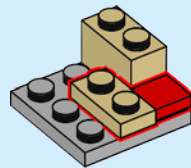

117

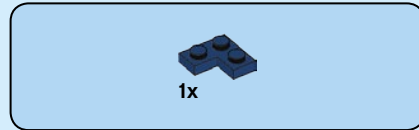
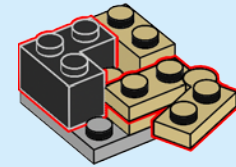

118

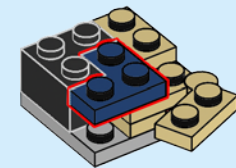

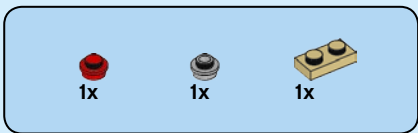

119

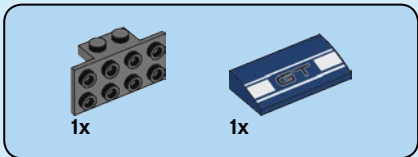
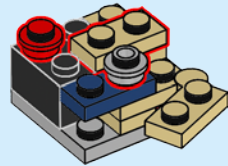

120

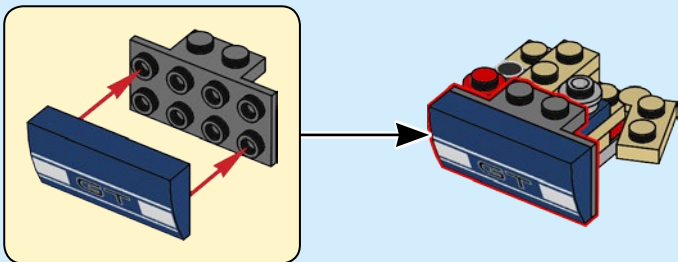

121

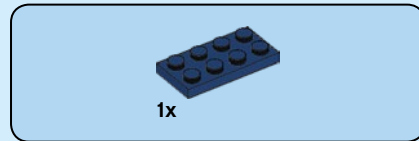
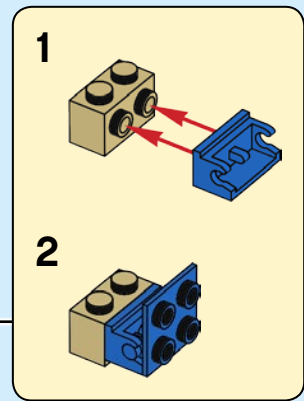
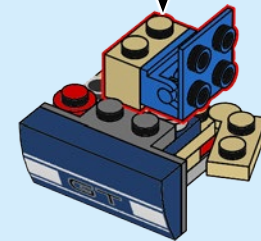

122

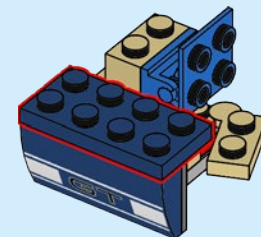

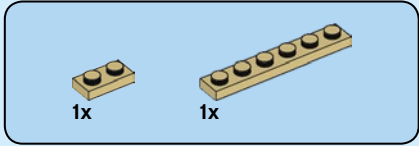
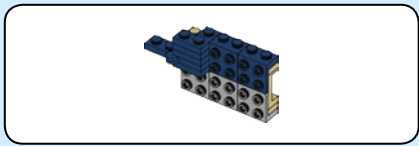

123

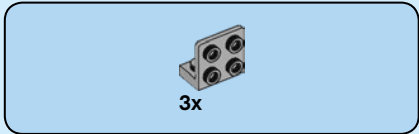
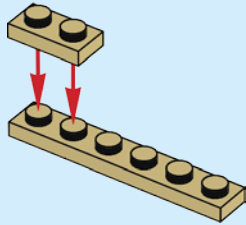

124

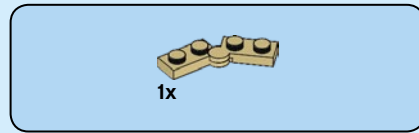
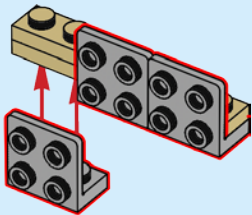

125

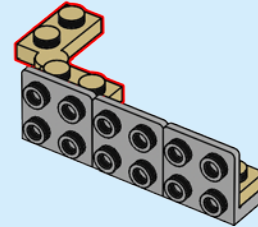

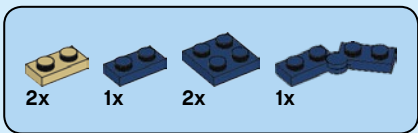

126

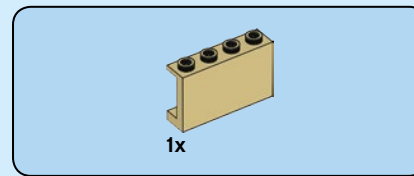
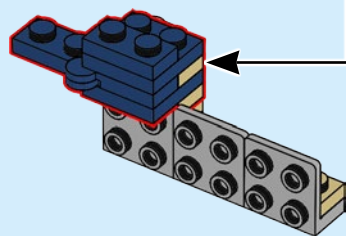
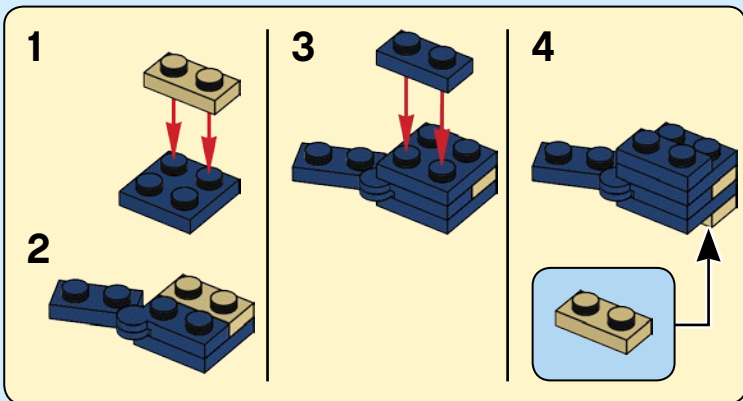

127

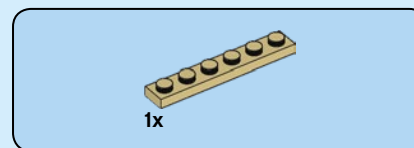
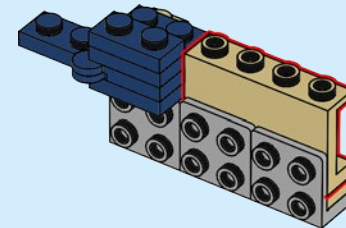

128

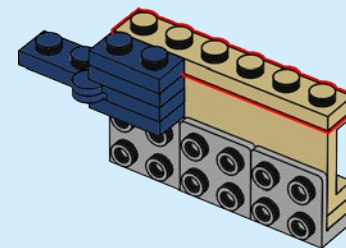

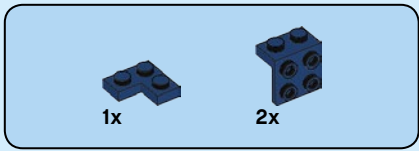

129

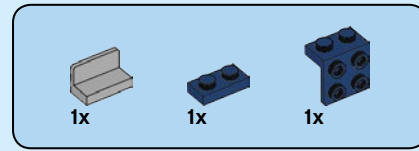
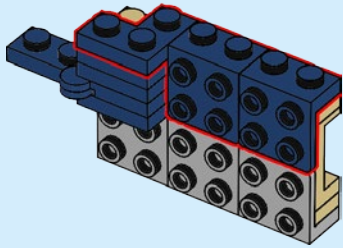

131

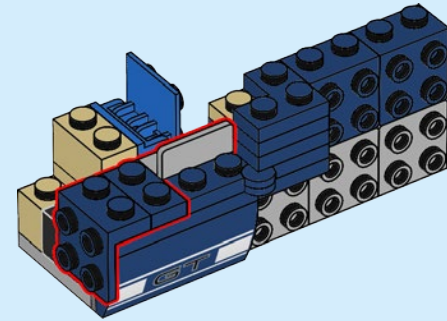

130

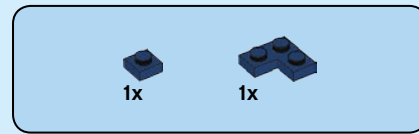
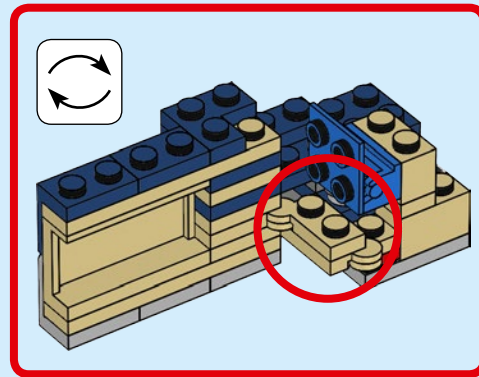
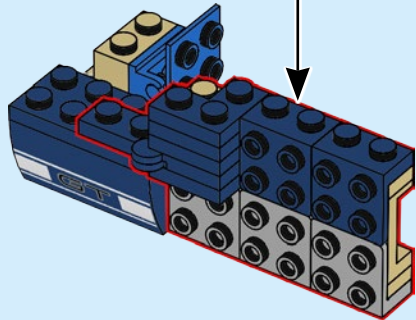

132

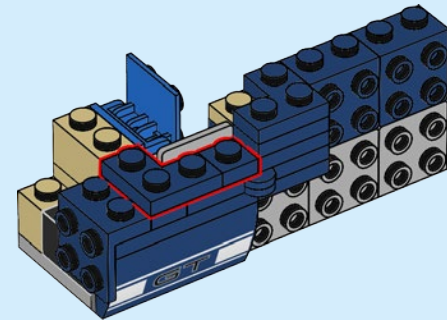

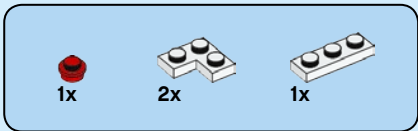

133

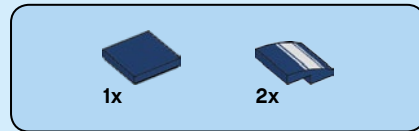
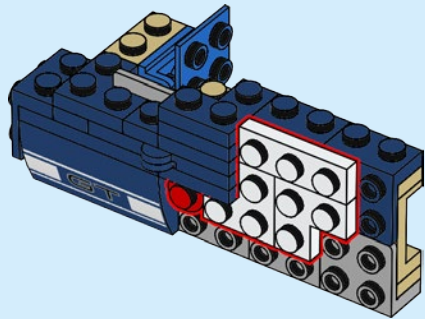

134

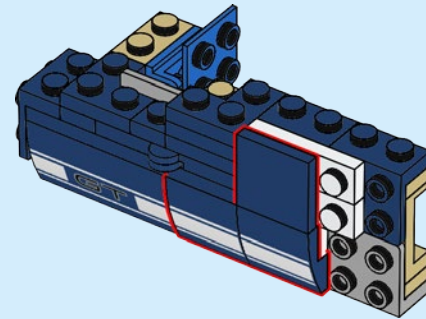

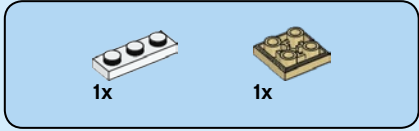
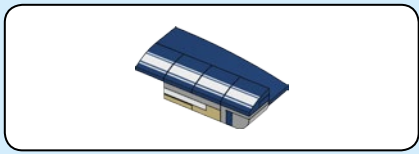

135

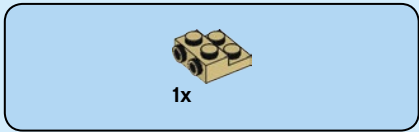
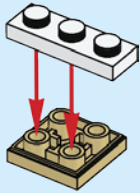

136

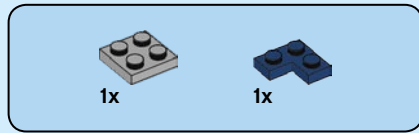
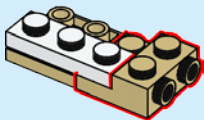

137

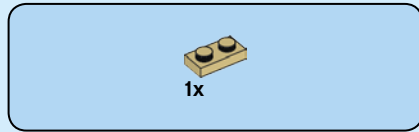
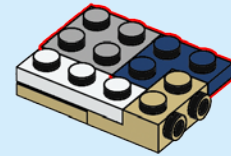

138

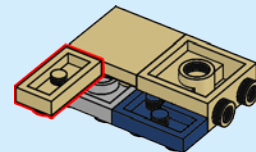
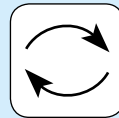

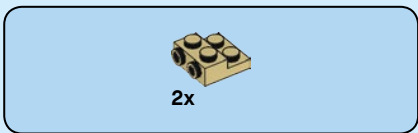

139

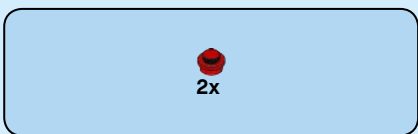
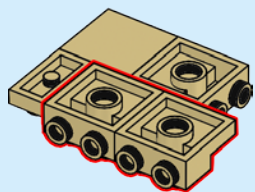

140

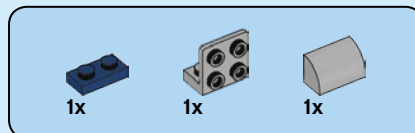
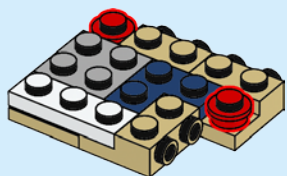
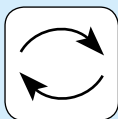

141

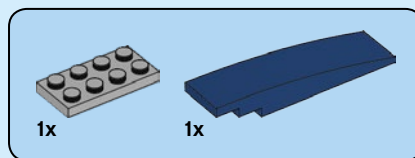
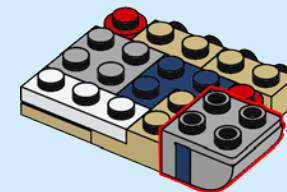
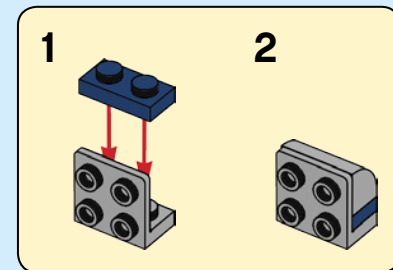

142

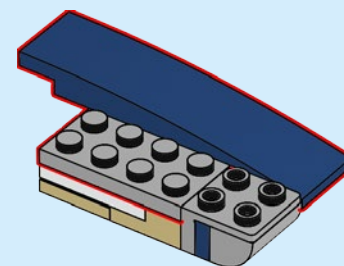

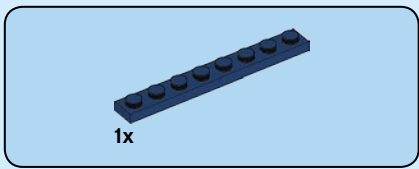

143

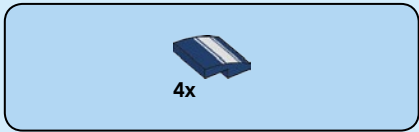
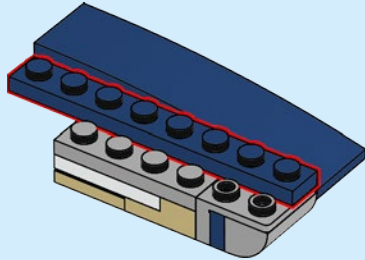

144

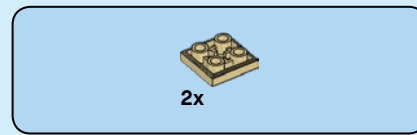
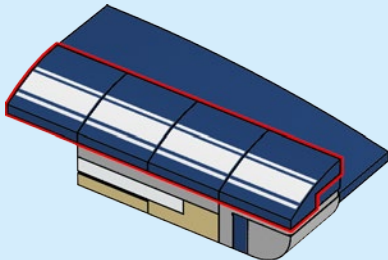

145

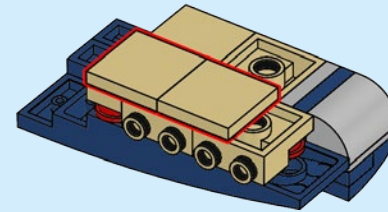
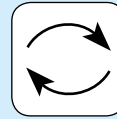

146

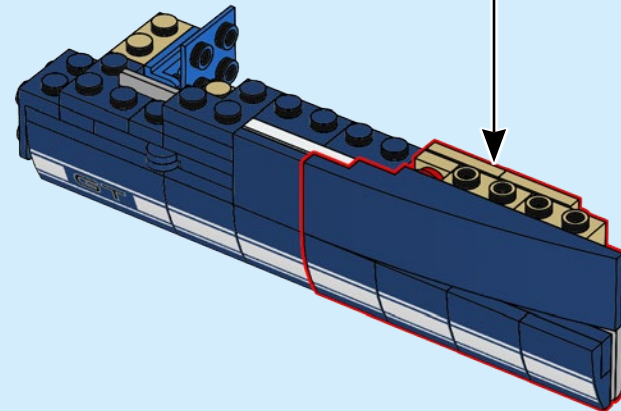

147

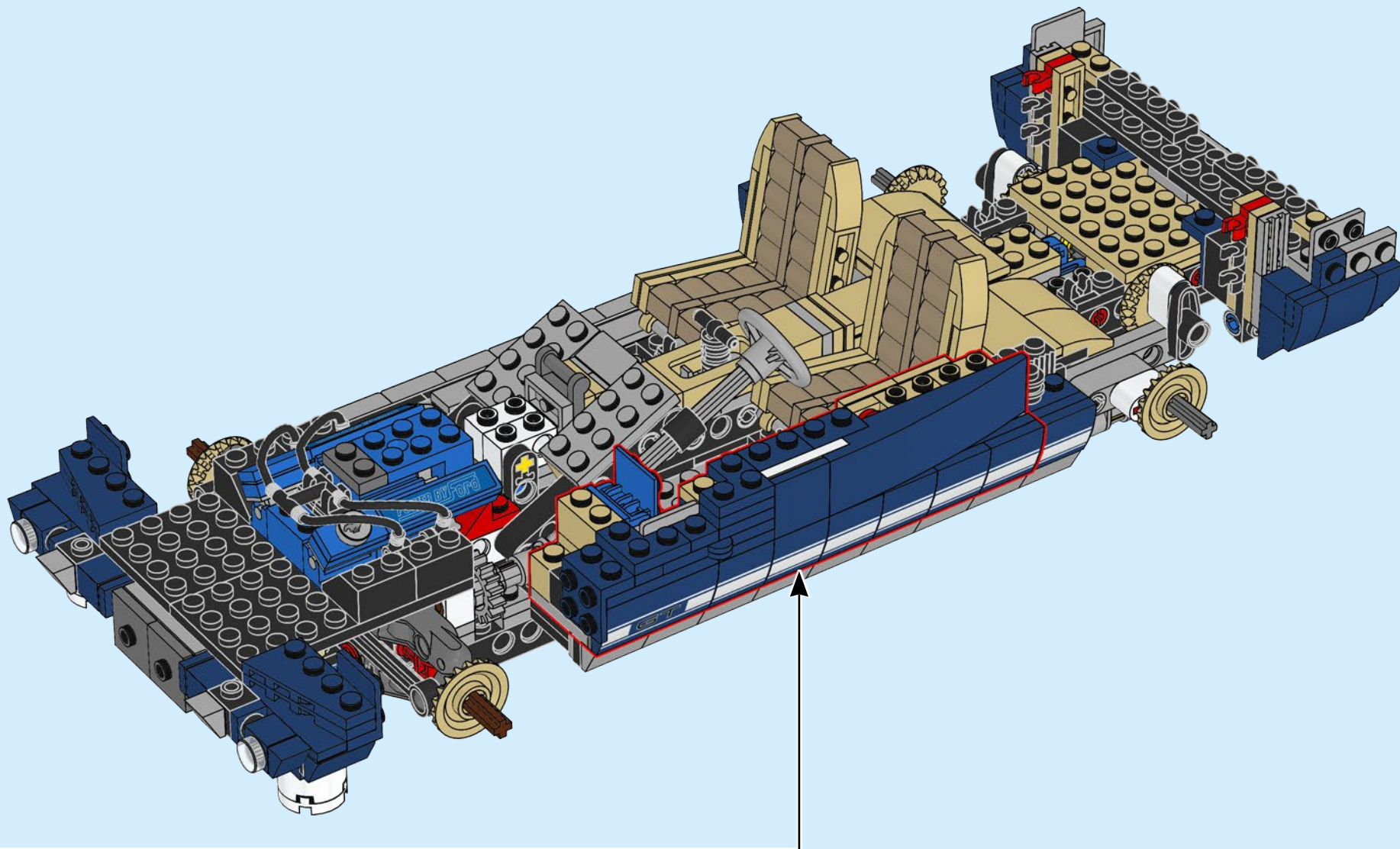

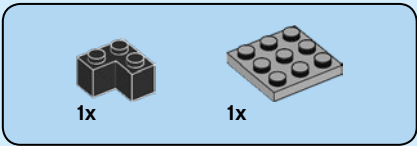
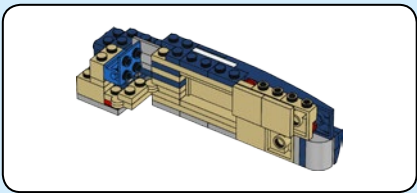

148

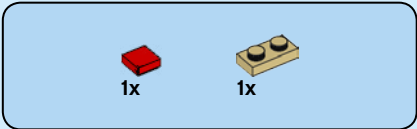
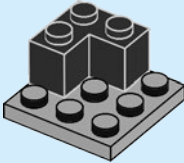

149

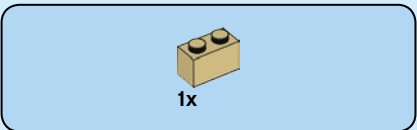
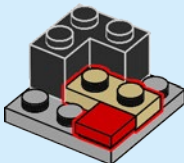

150

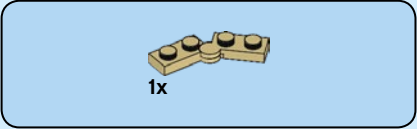
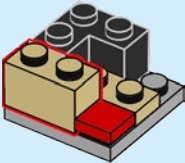

151

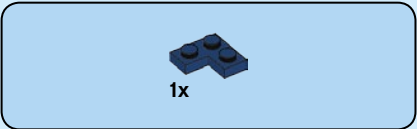
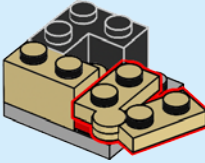

152

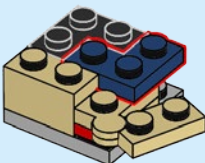

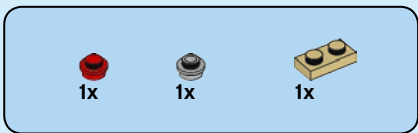

153

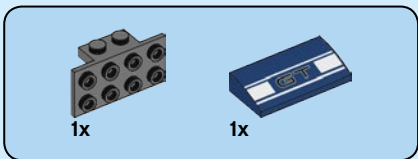
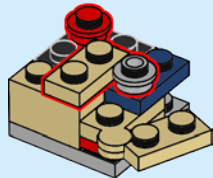

154

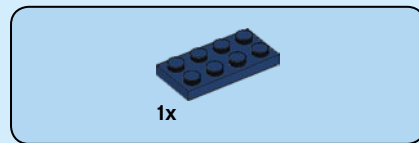
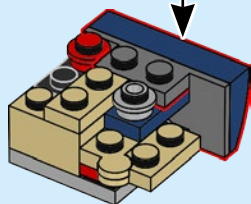
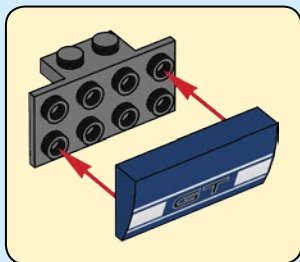

155

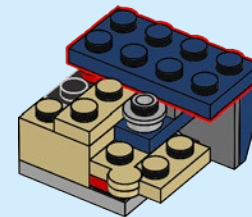

156

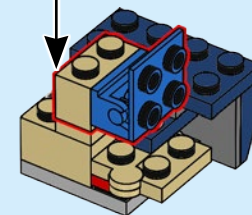
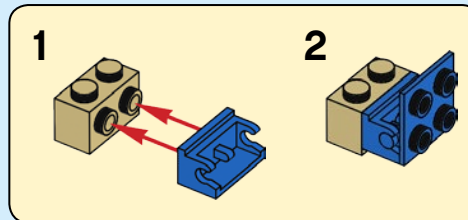

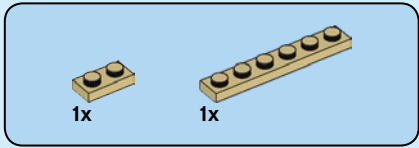
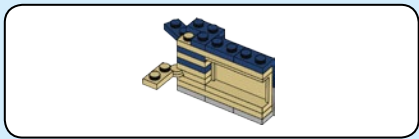

157

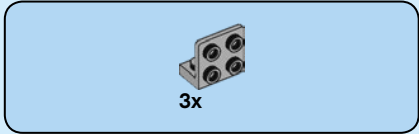
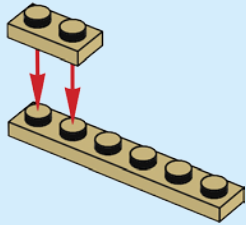

158

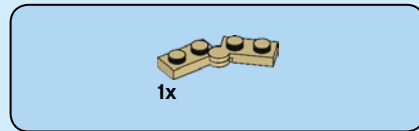
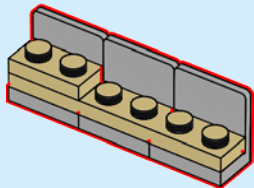

159

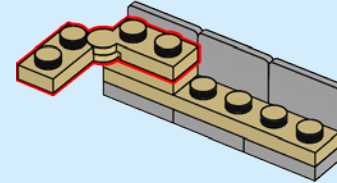

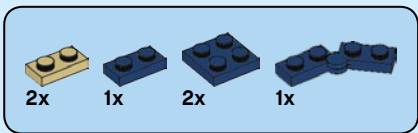

160

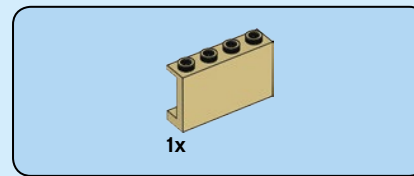
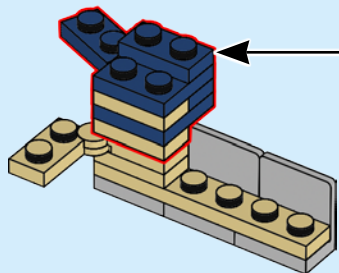
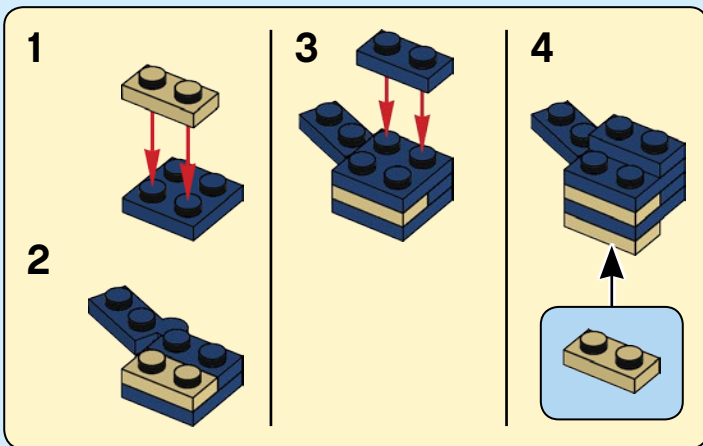

161

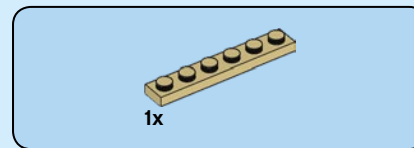
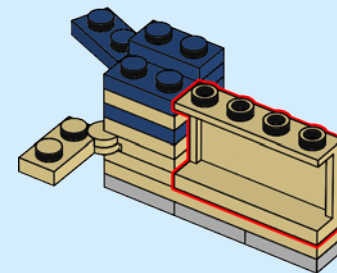

162

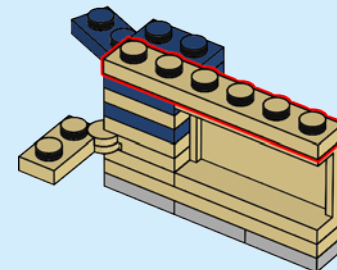

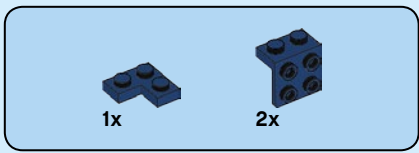

163

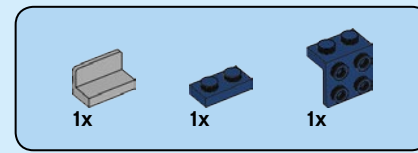
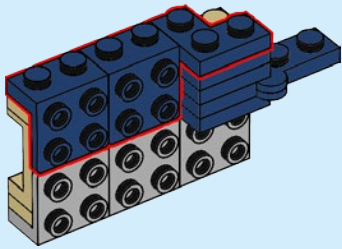
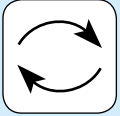

165

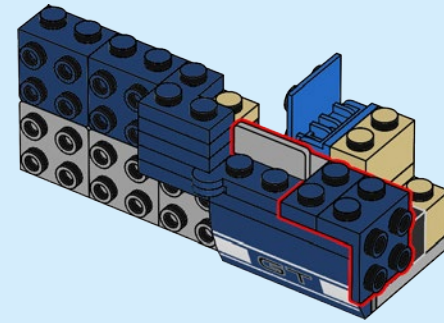

164

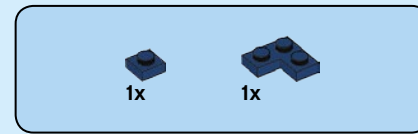
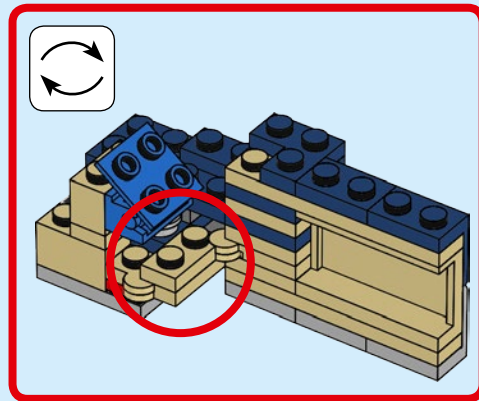
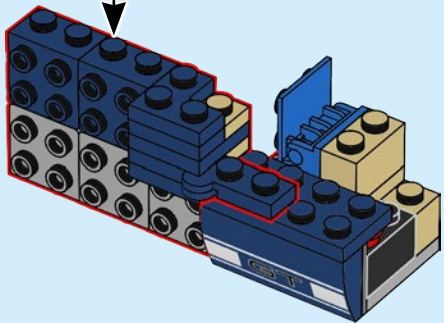

166

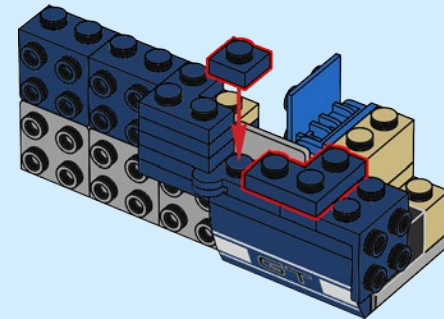

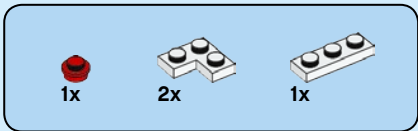

167

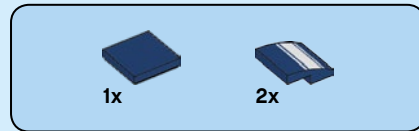
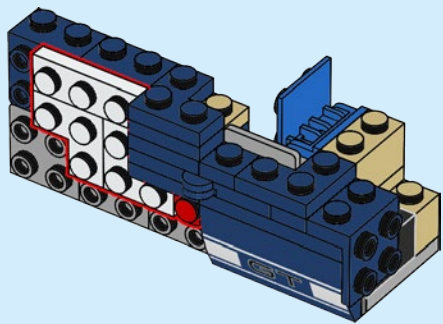

168

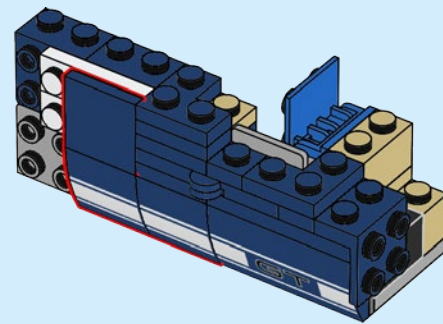

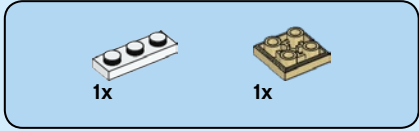
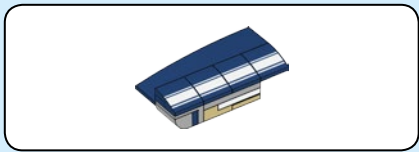

169

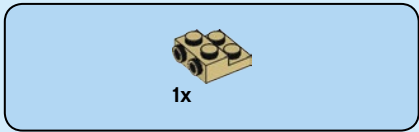
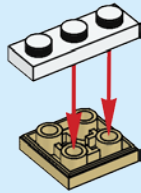

170

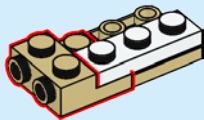

171

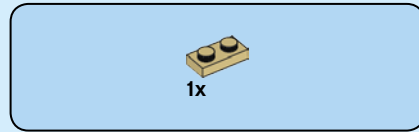
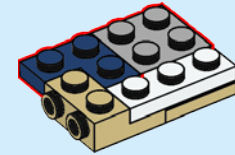

172

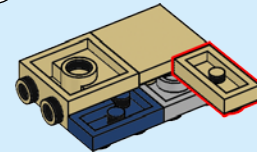
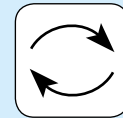



173

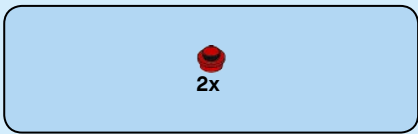
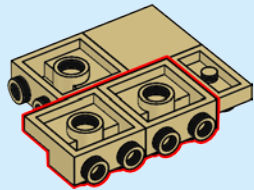

174

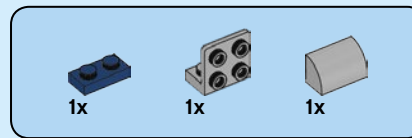
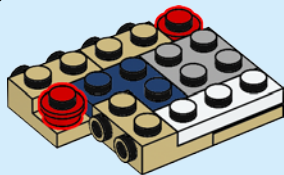
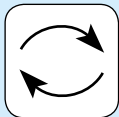

175

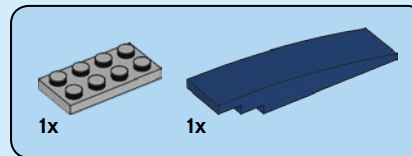
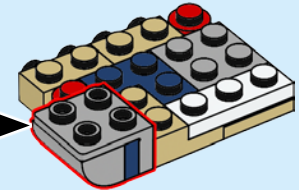
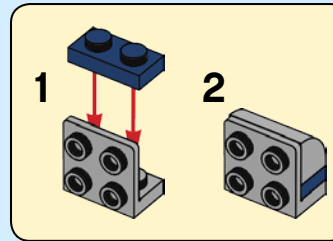

176

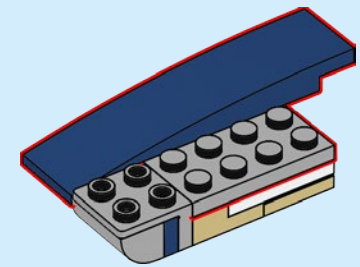

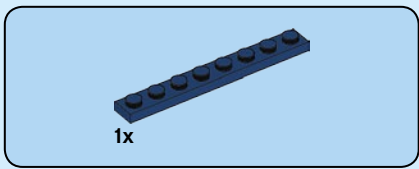

177

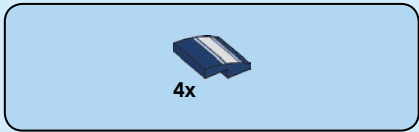
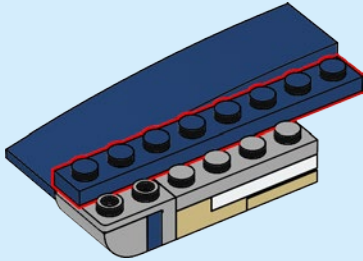

178

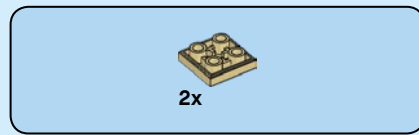
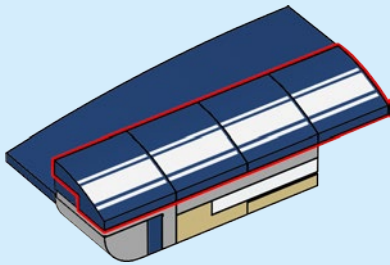

179

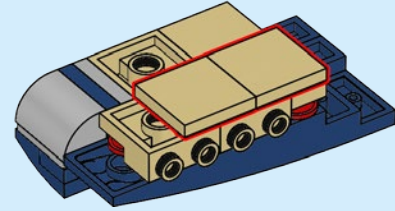
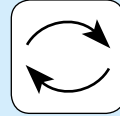

180

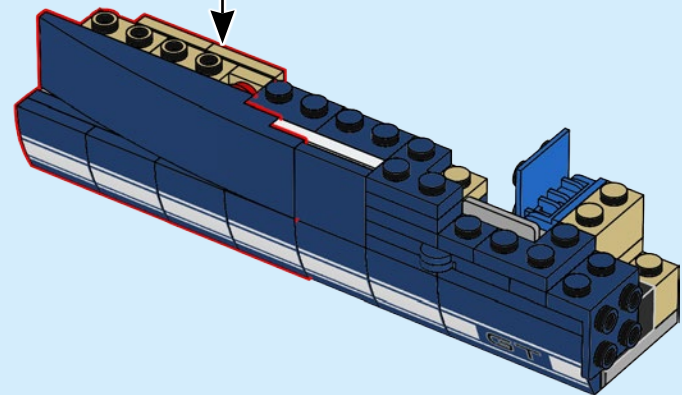

181

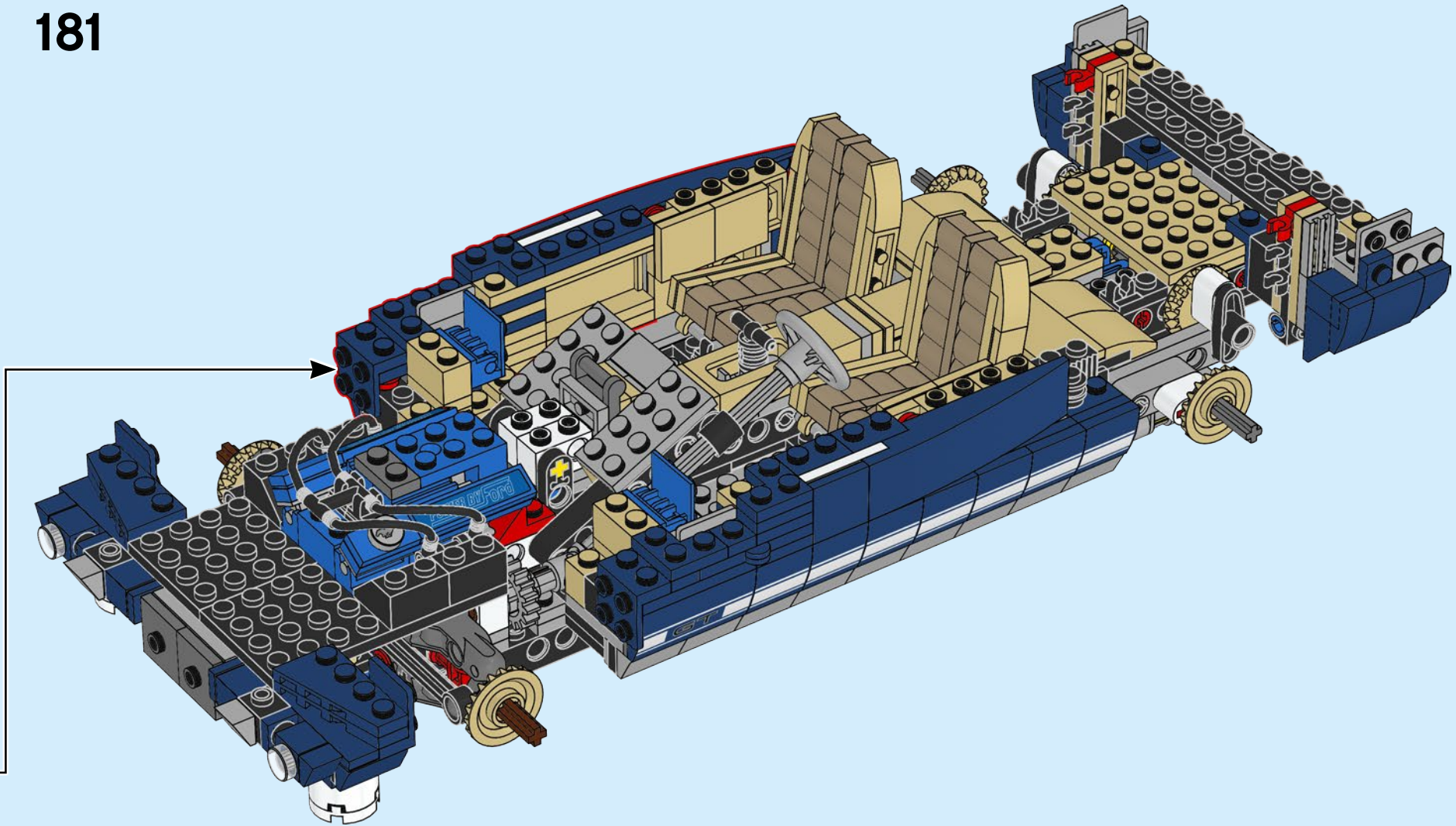

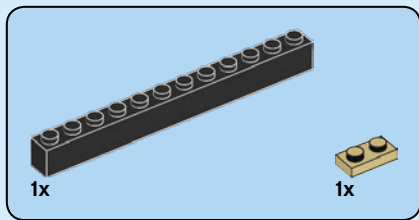

182

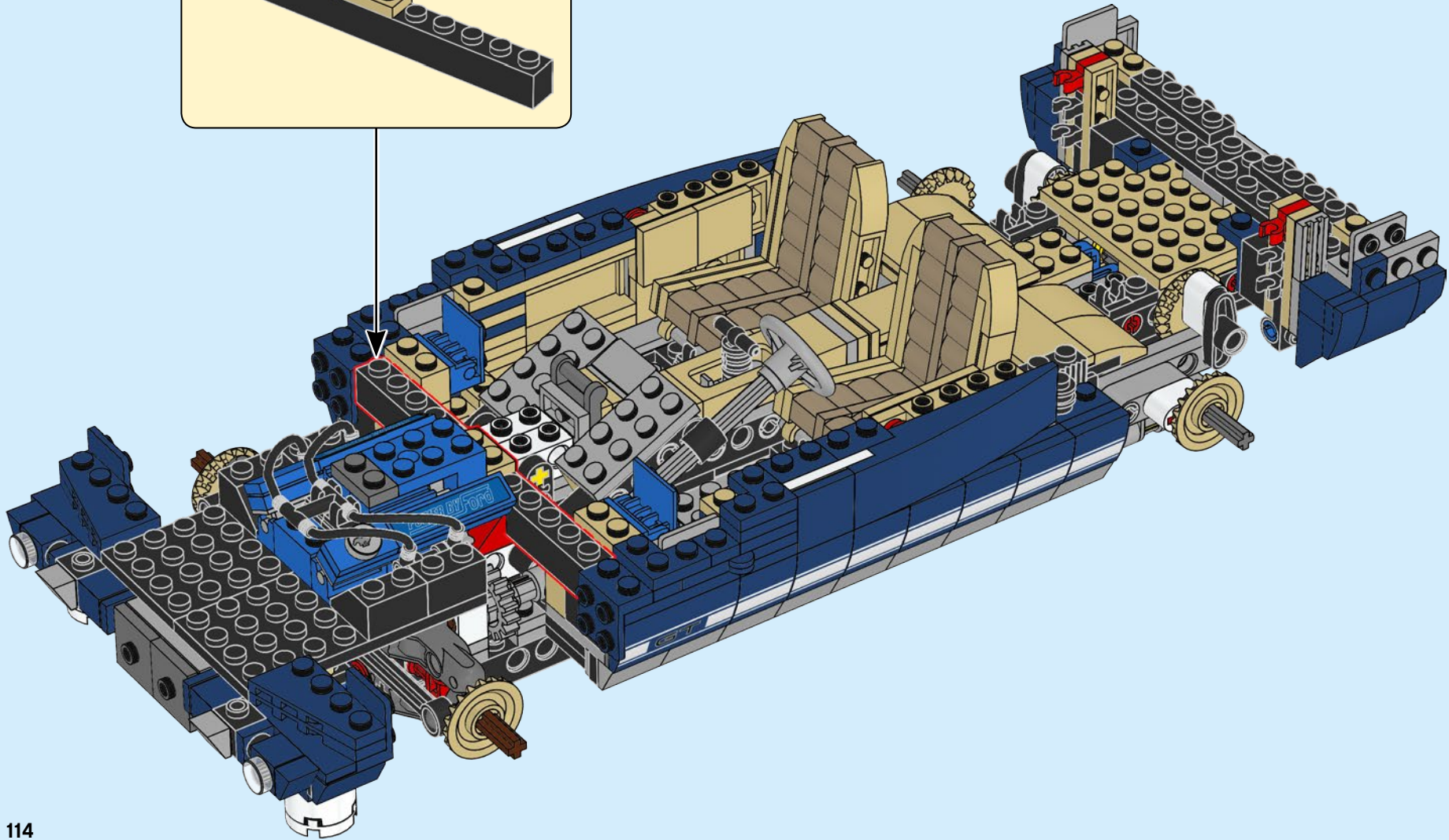
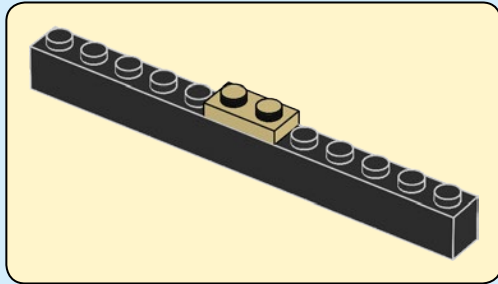

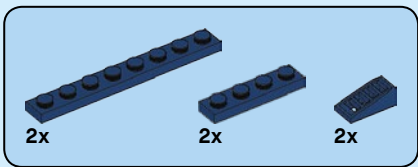

183

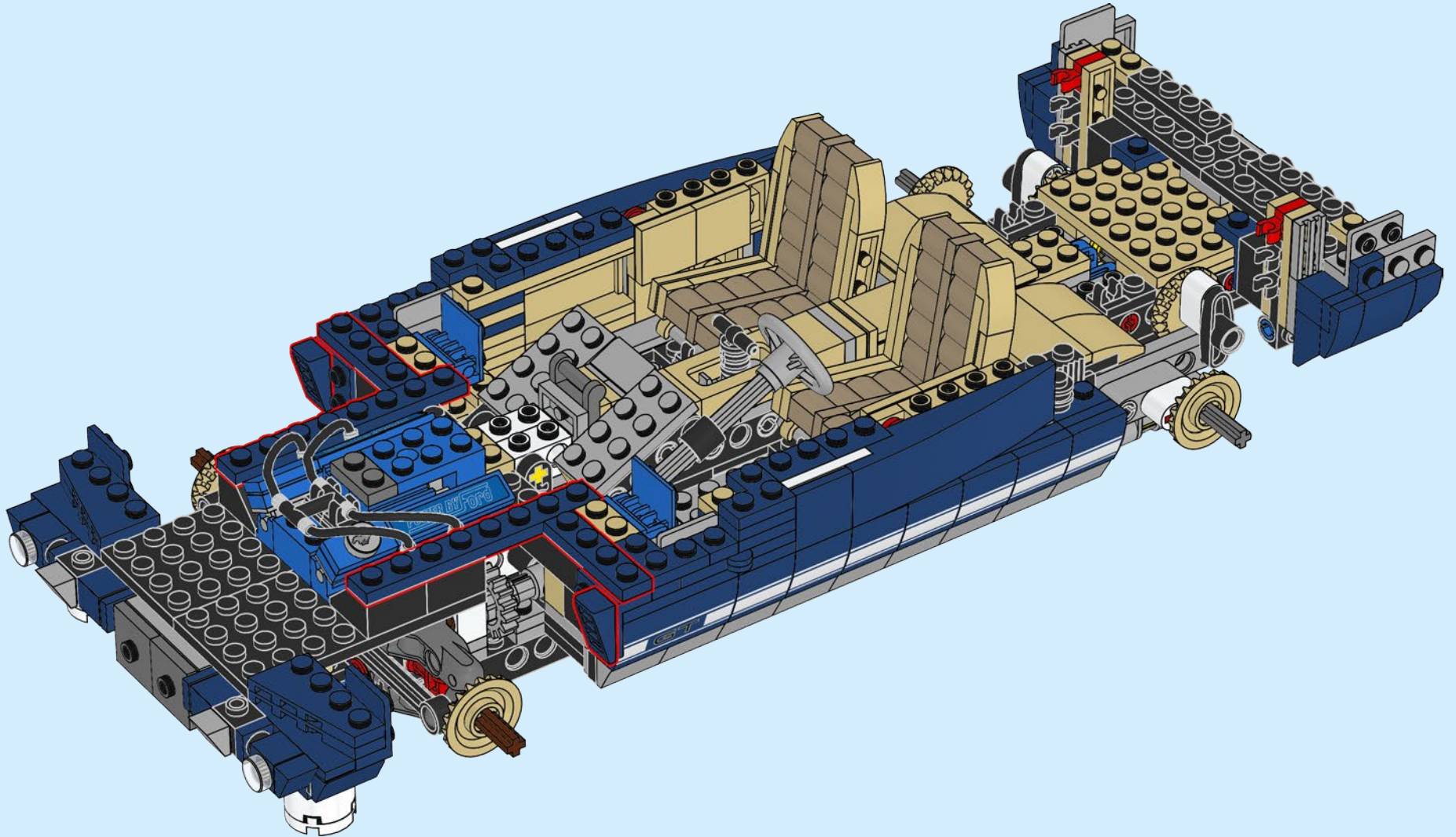

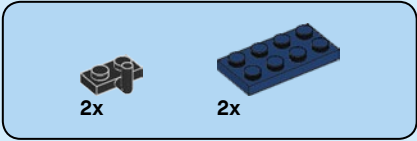

184

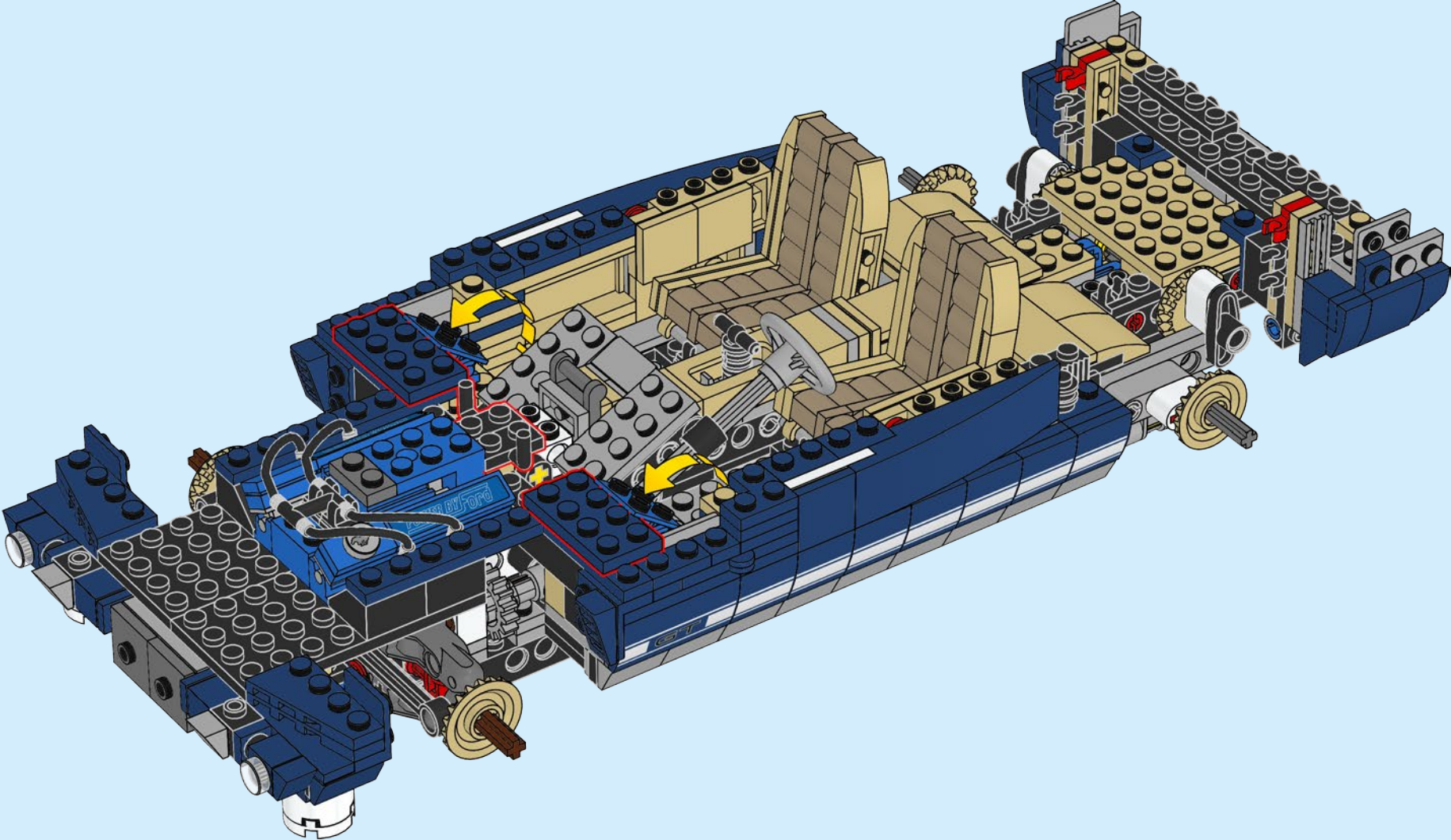

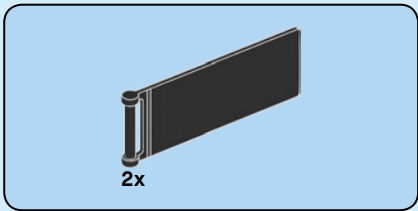
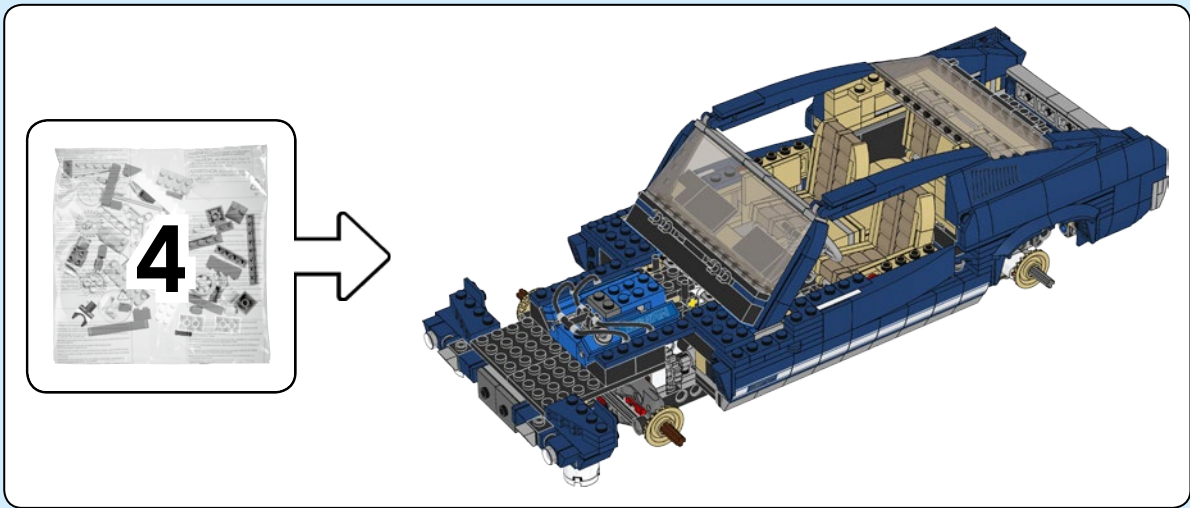

185

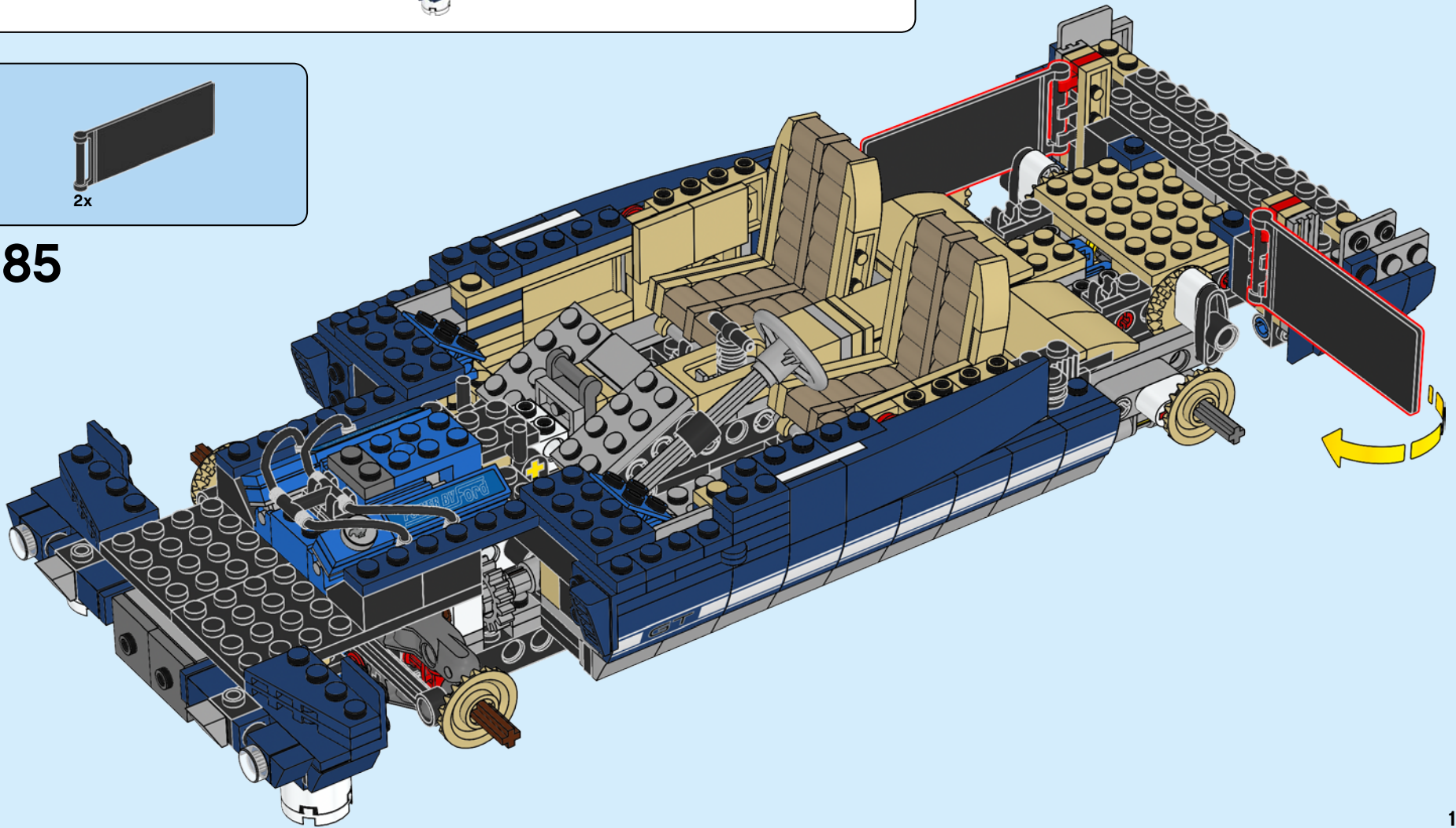



2x

186

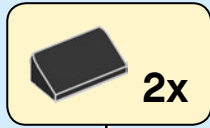

2x

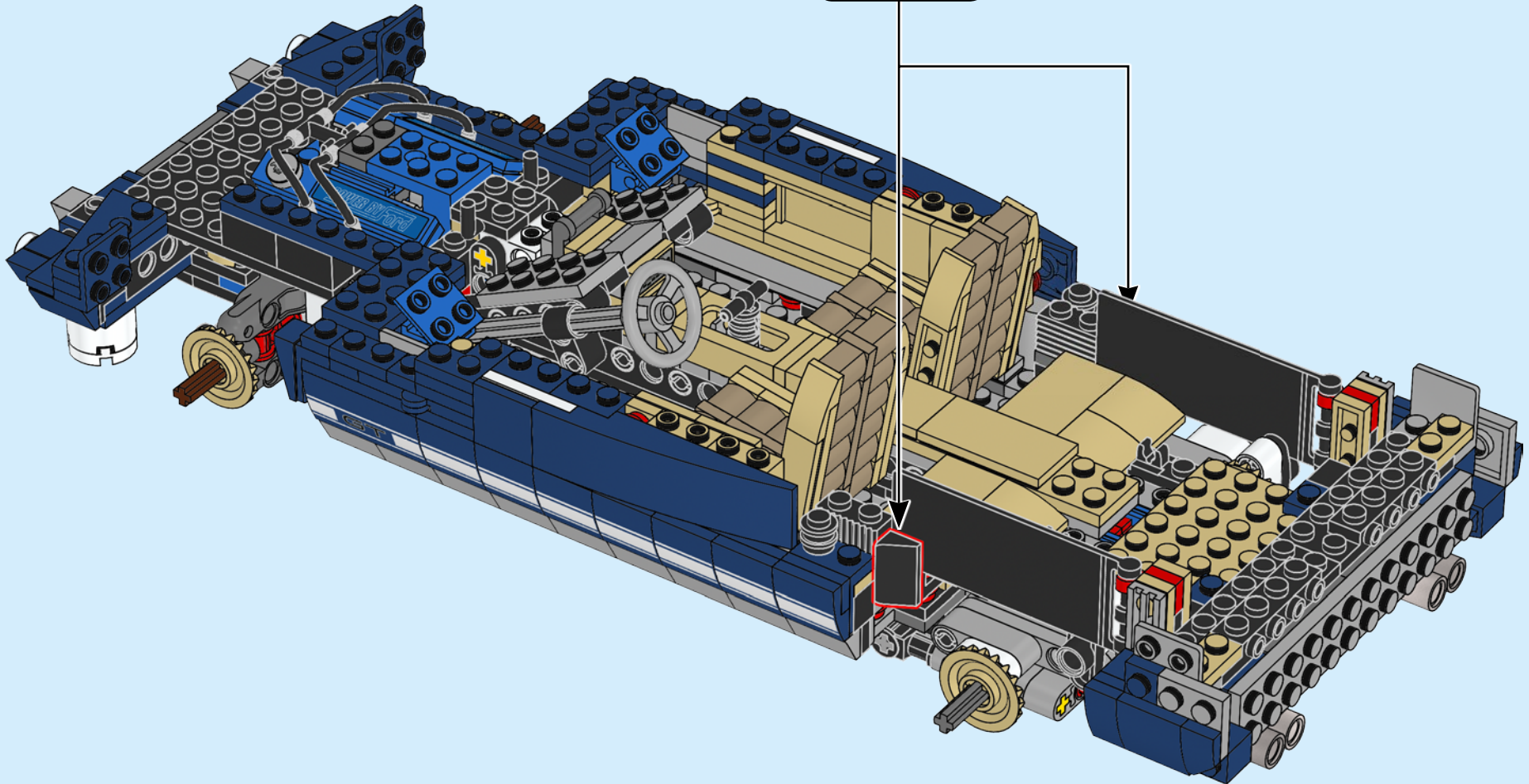

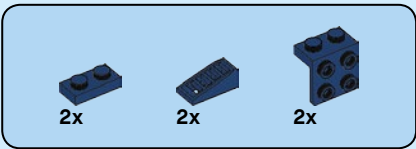

187

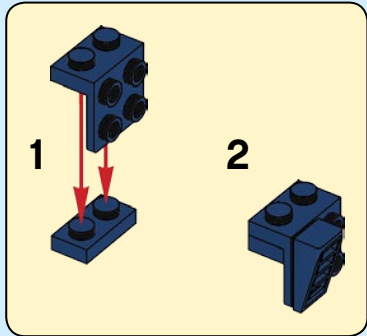
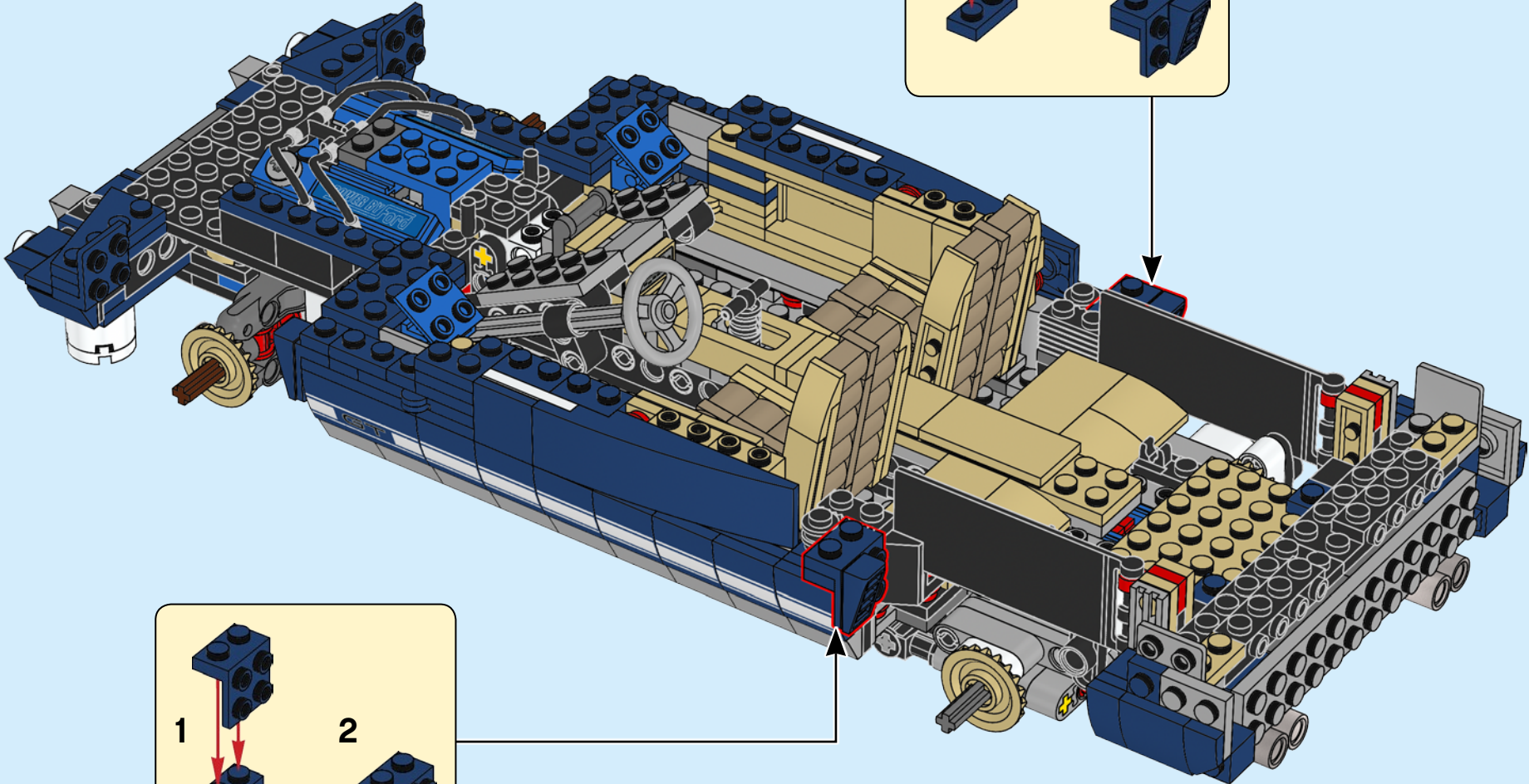
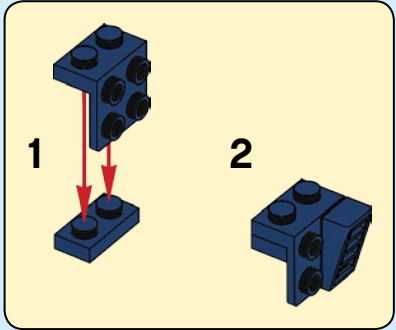

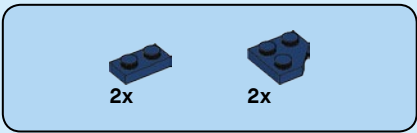

188

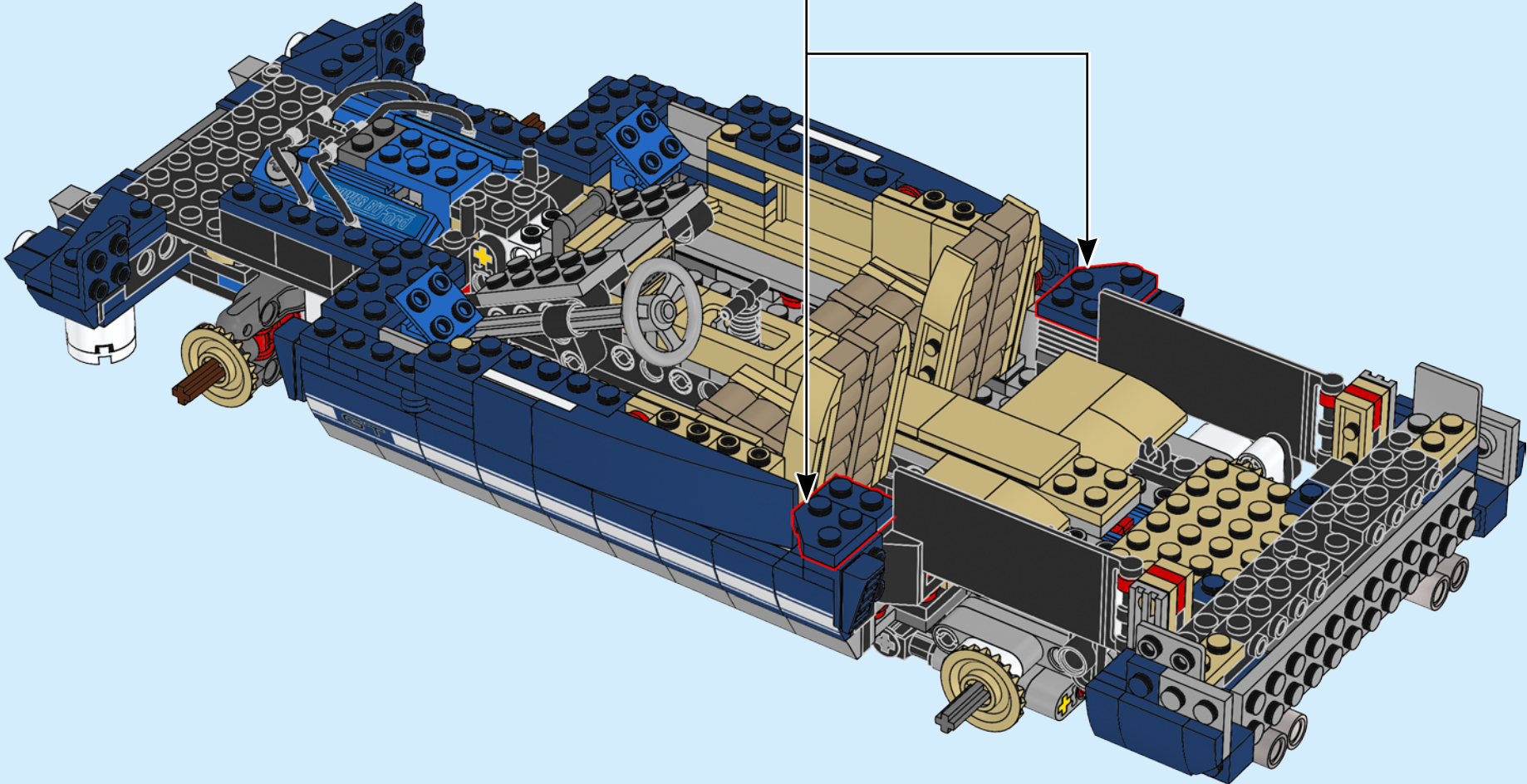
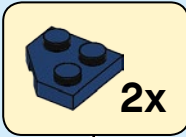

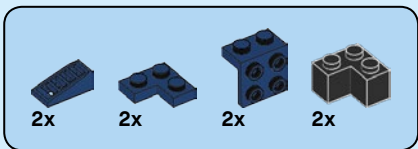

189

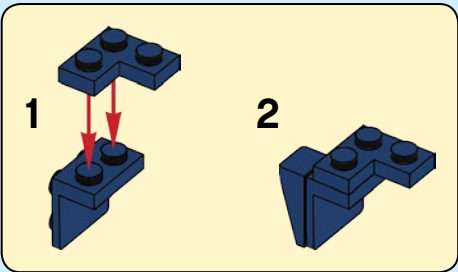
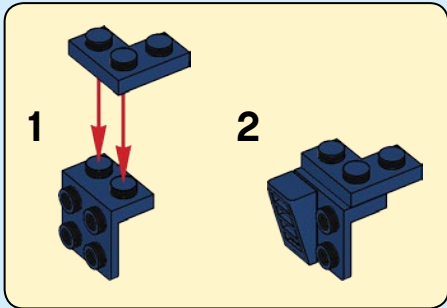
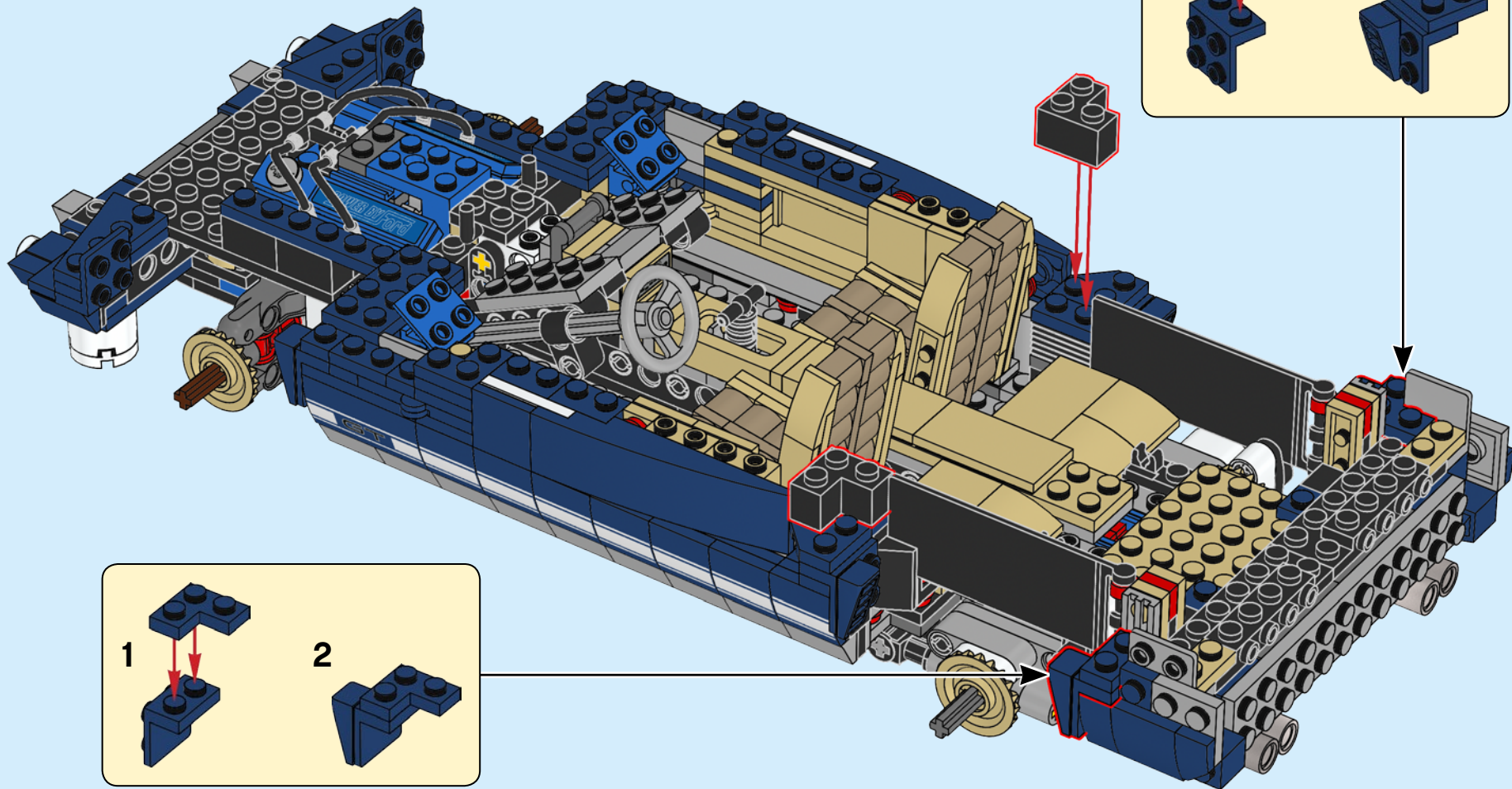

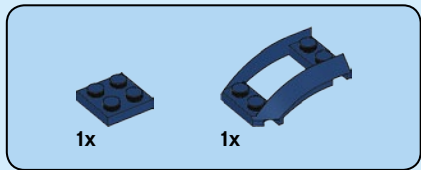

190

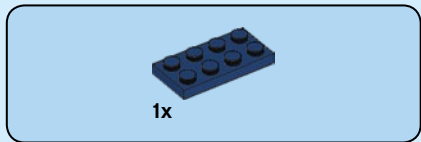
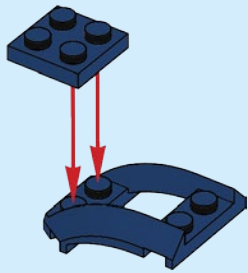

191

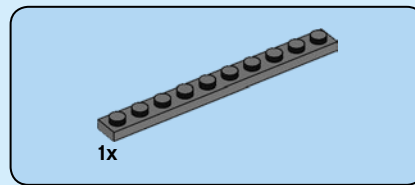
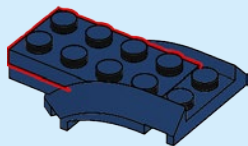

192

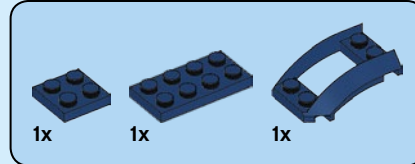
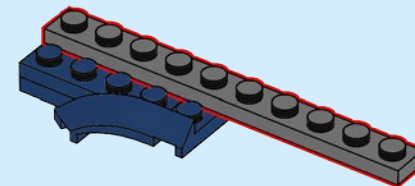

193

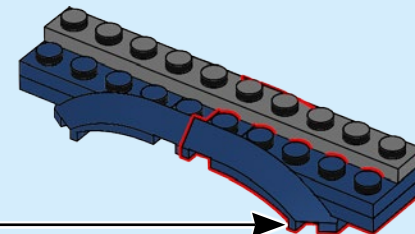
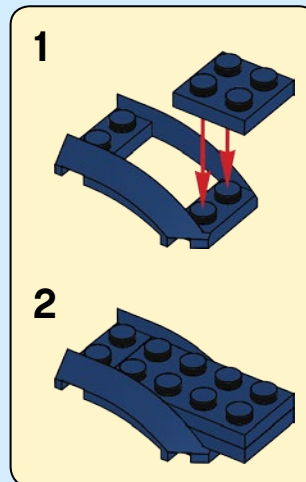

2x

194

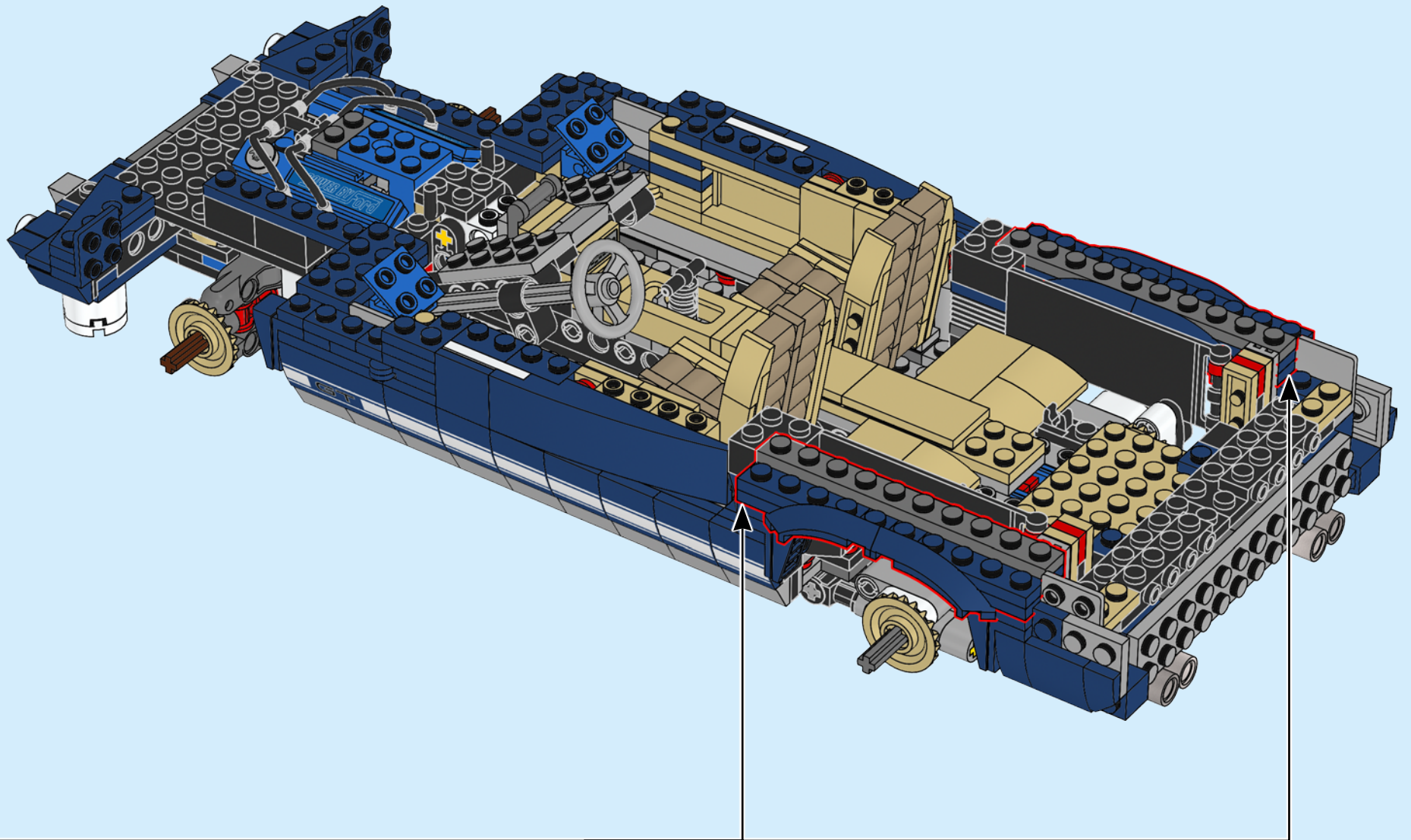

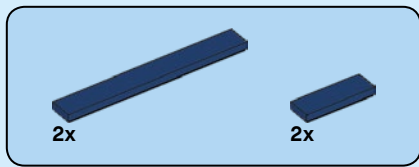

195

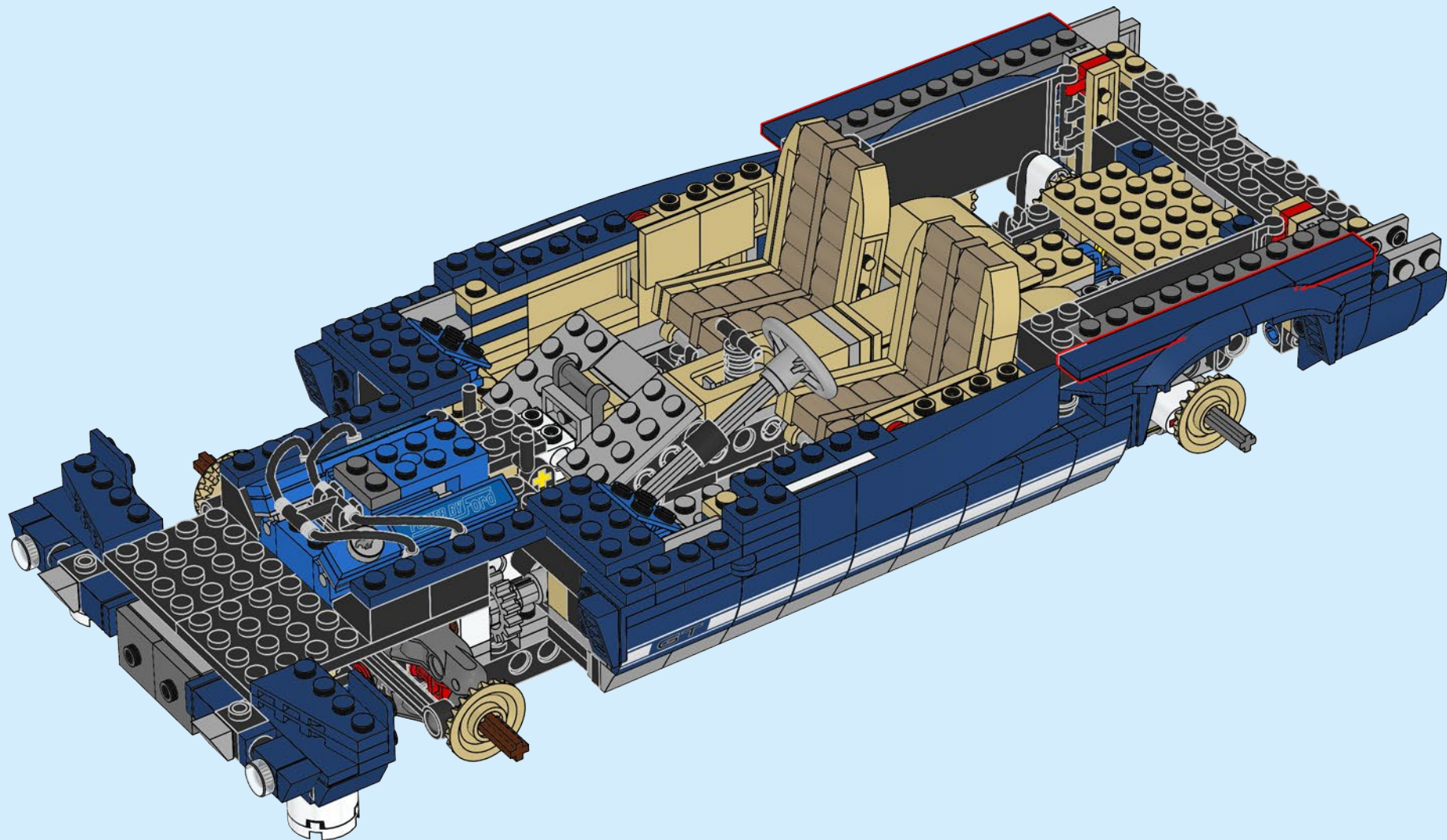

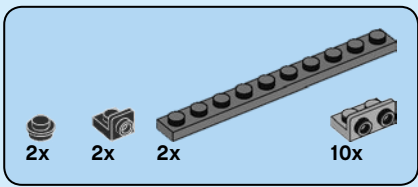

196

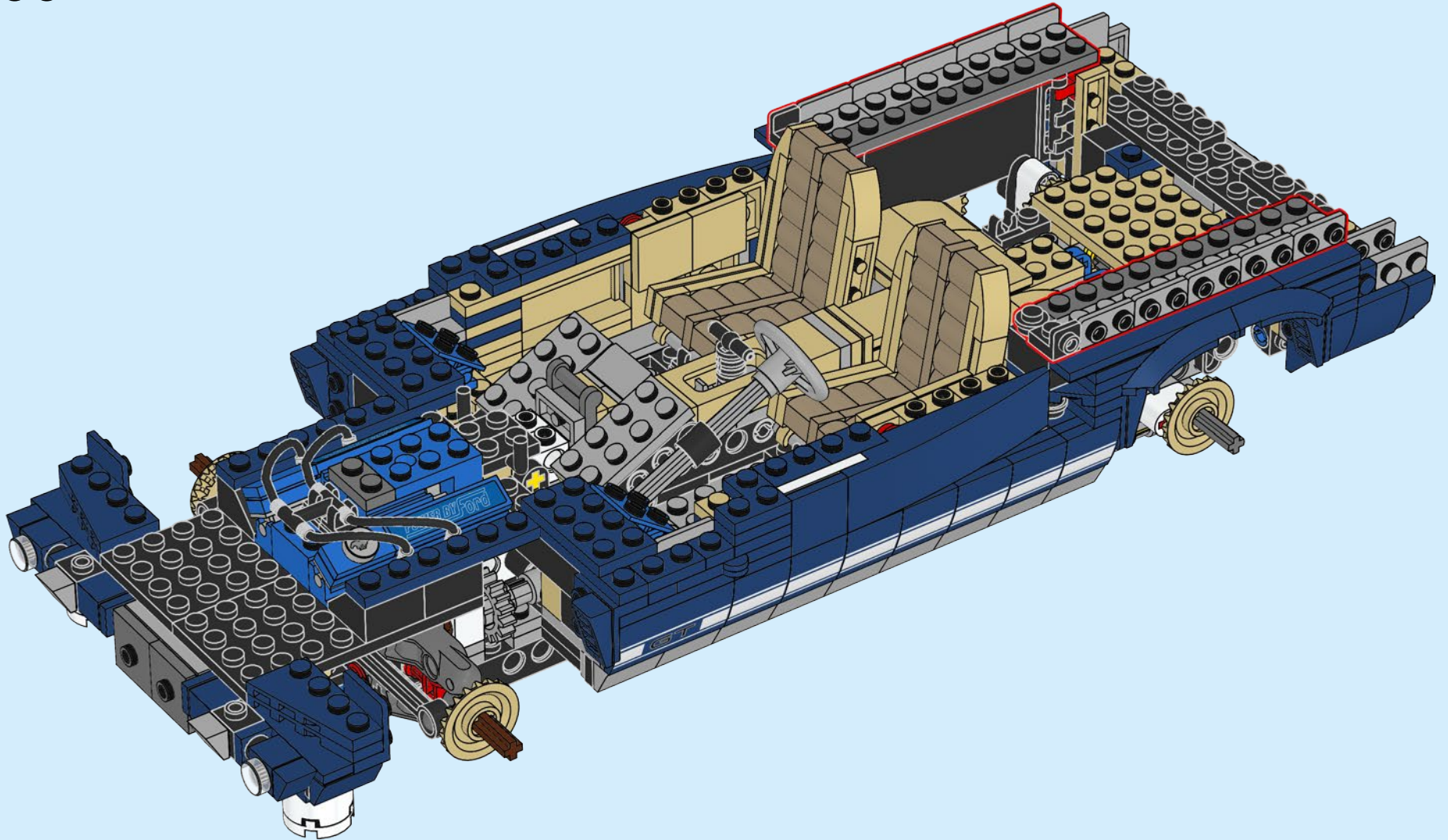

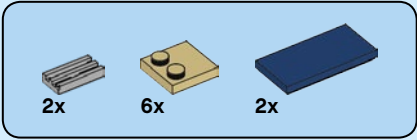

197

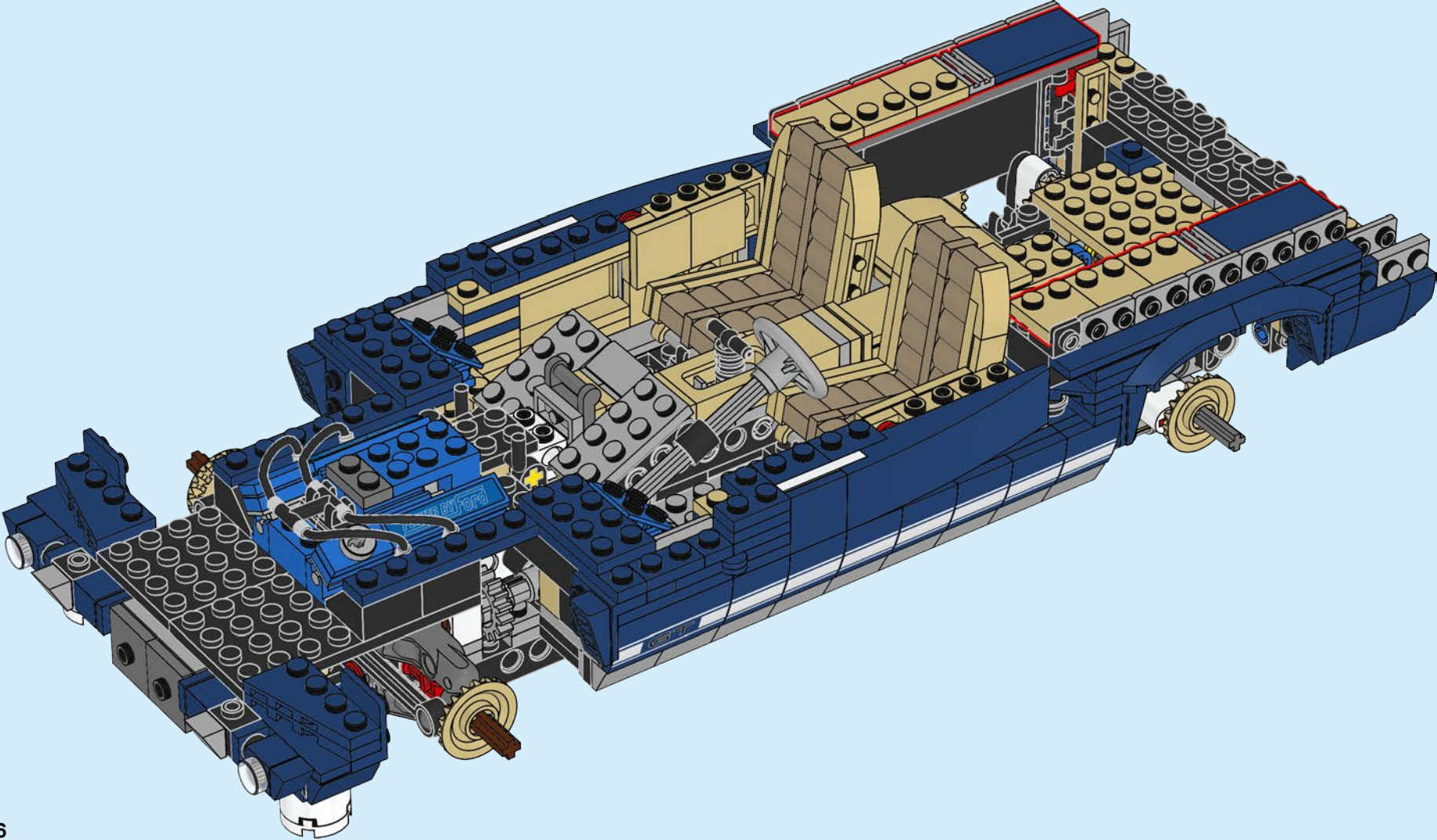

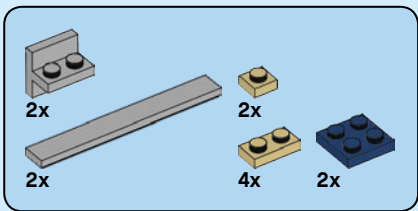

198

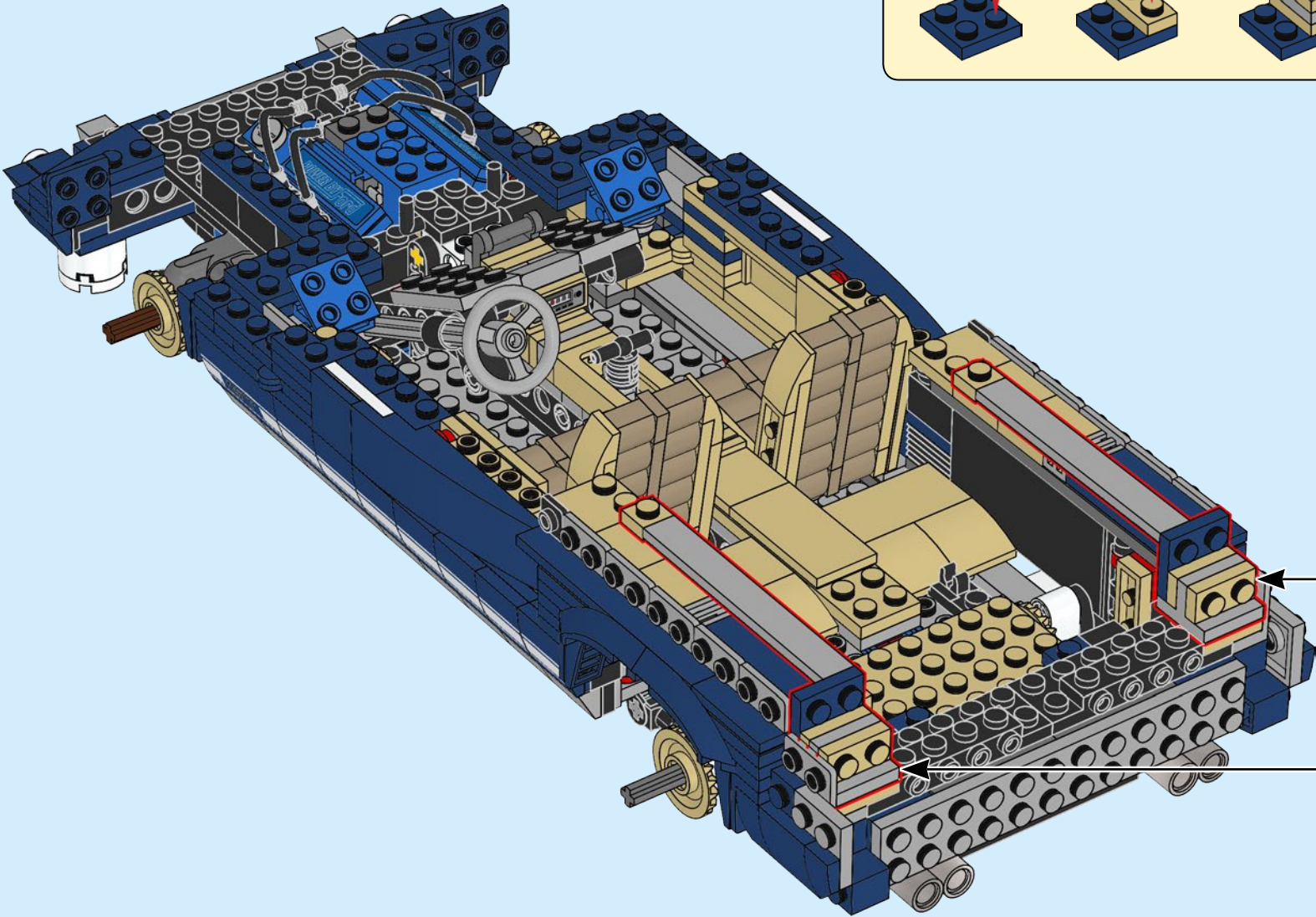
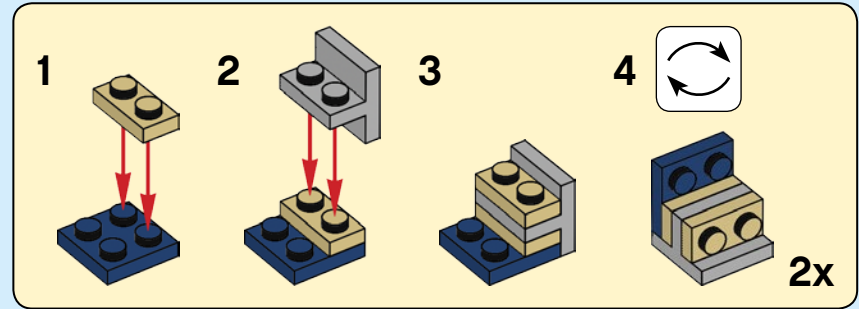

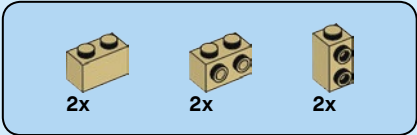

199

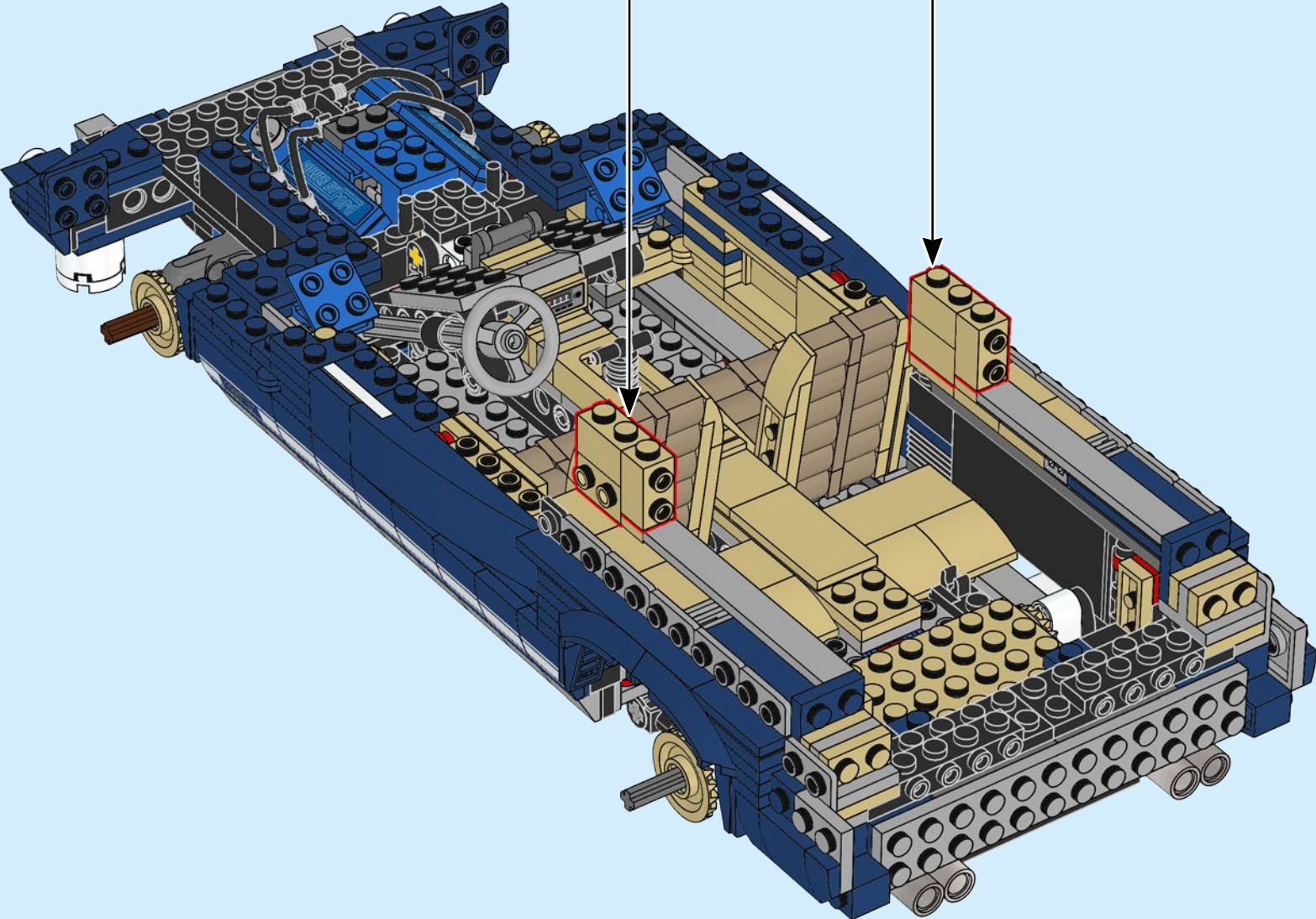
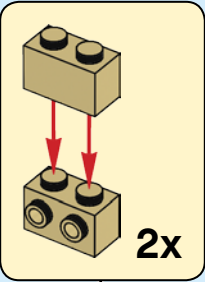

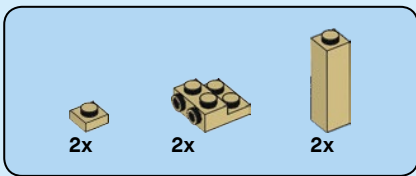

200

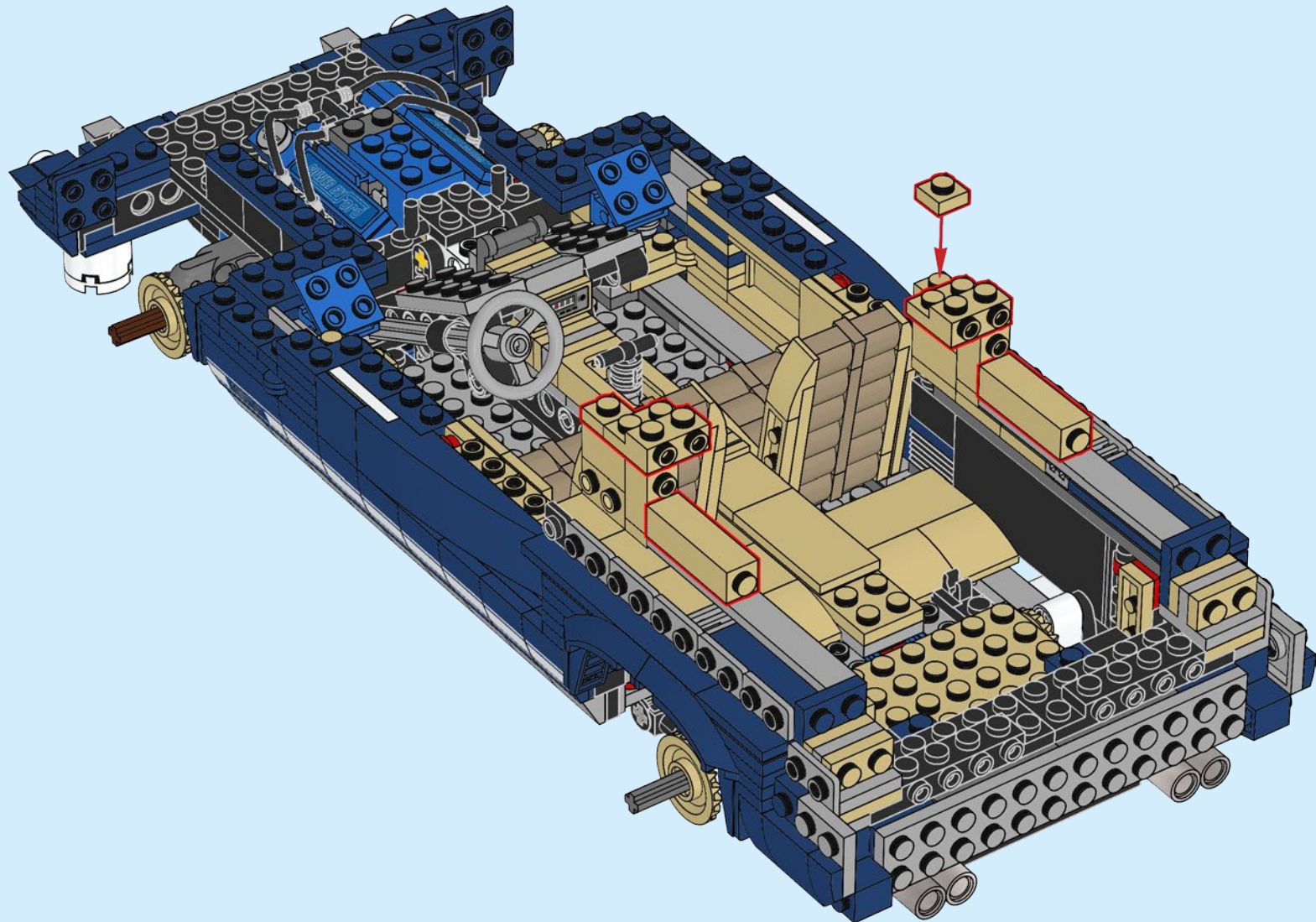

Ford's 300 millionth car was a special edition Mustang - a GT convertible.

La 300 millionième voiture de Ford était une Mustang édition spéciale - une GT décapotable.

El auto número 300 millones de Ford fue una edición especial del Mustang: un GT convertible.

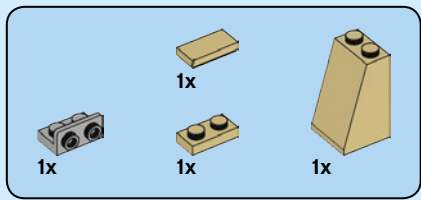

201

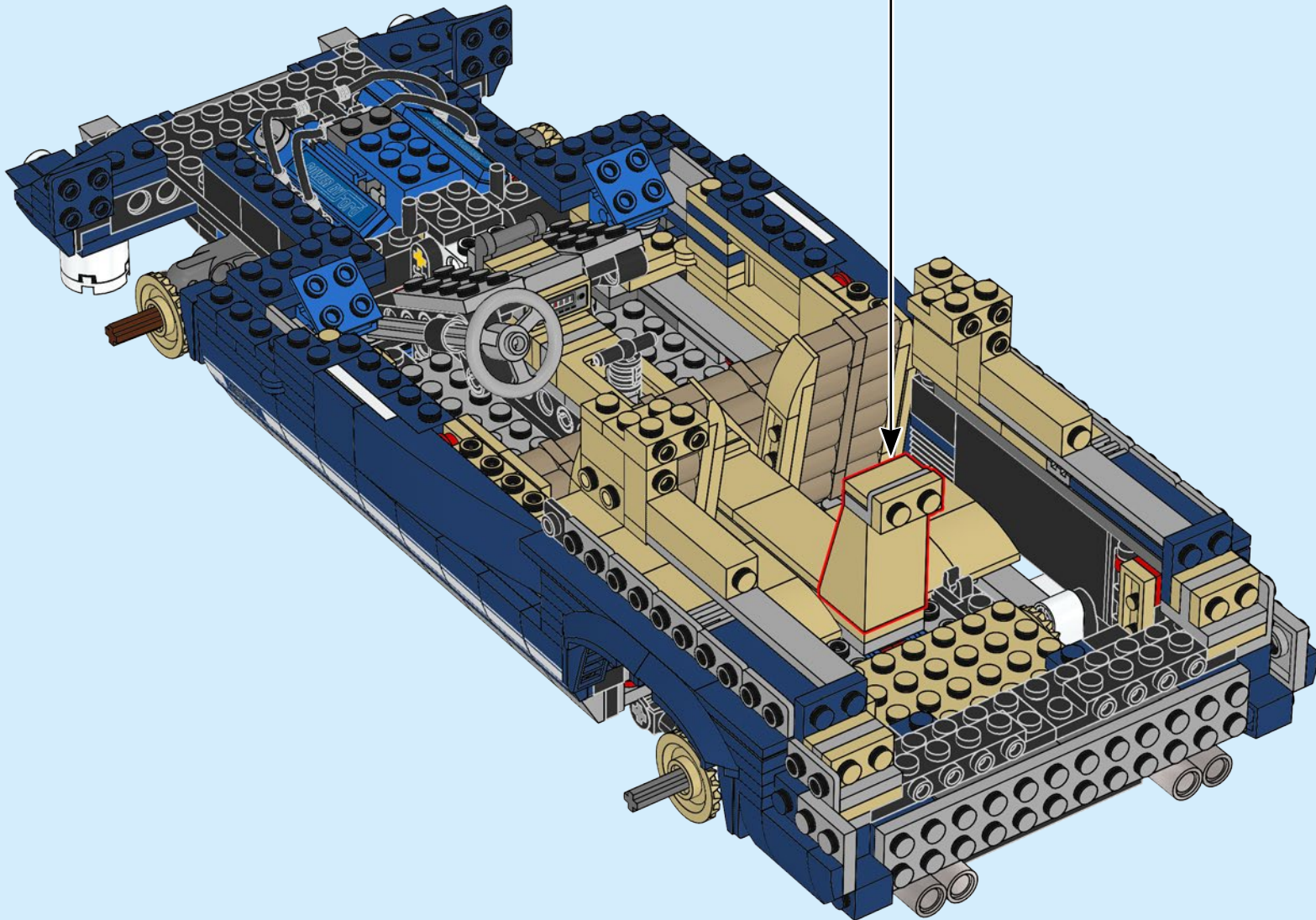
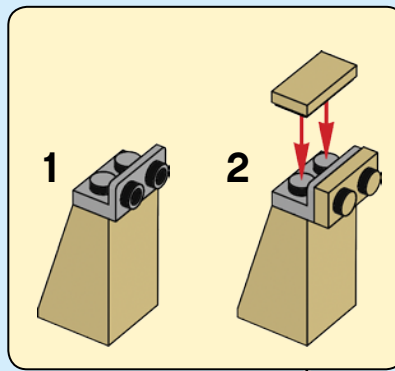

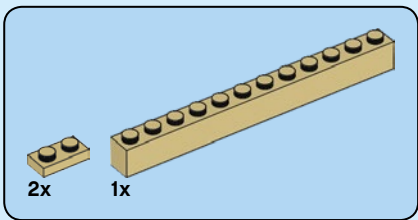

202

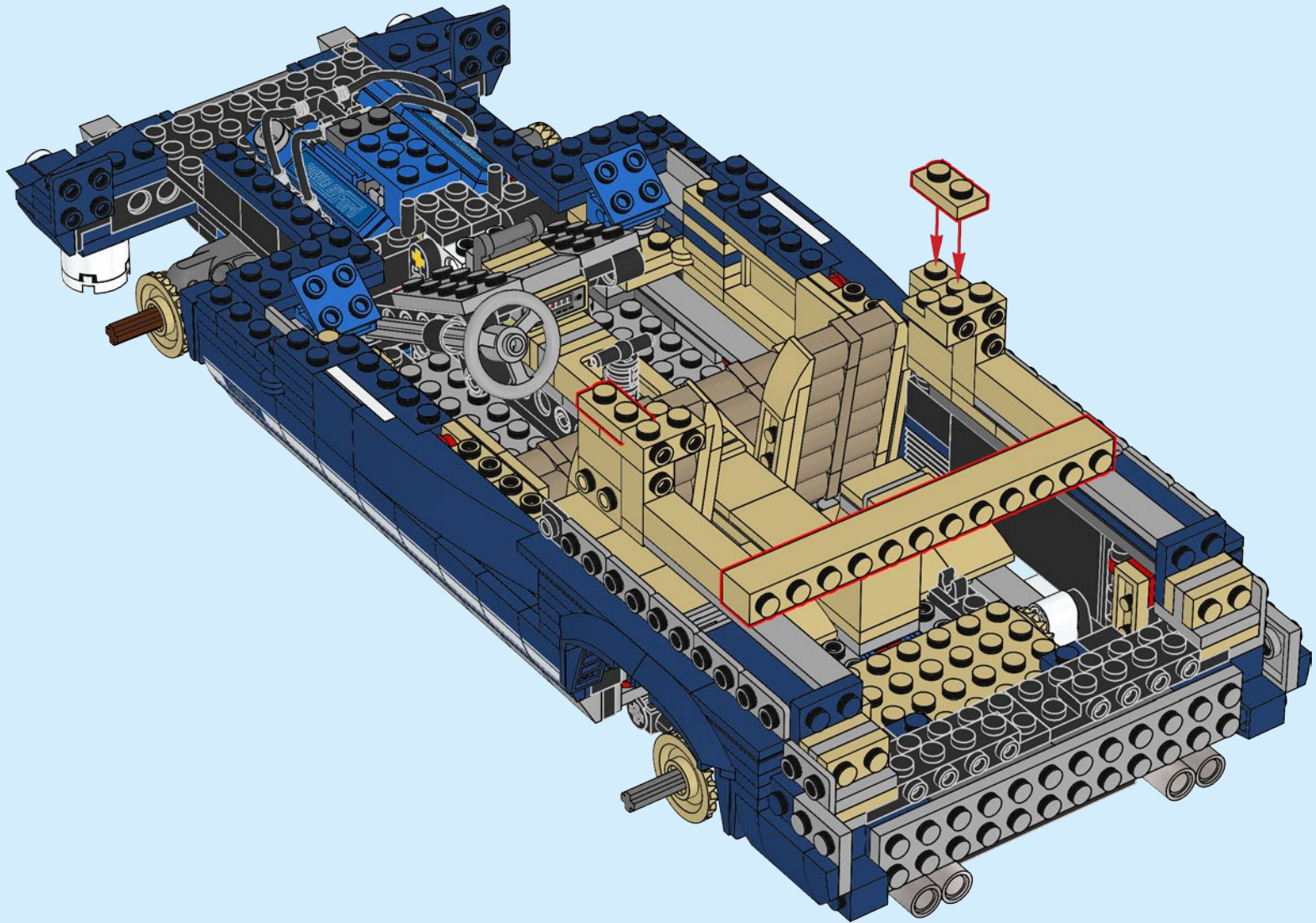

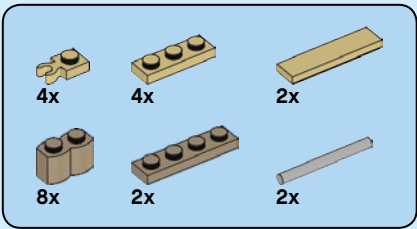

203

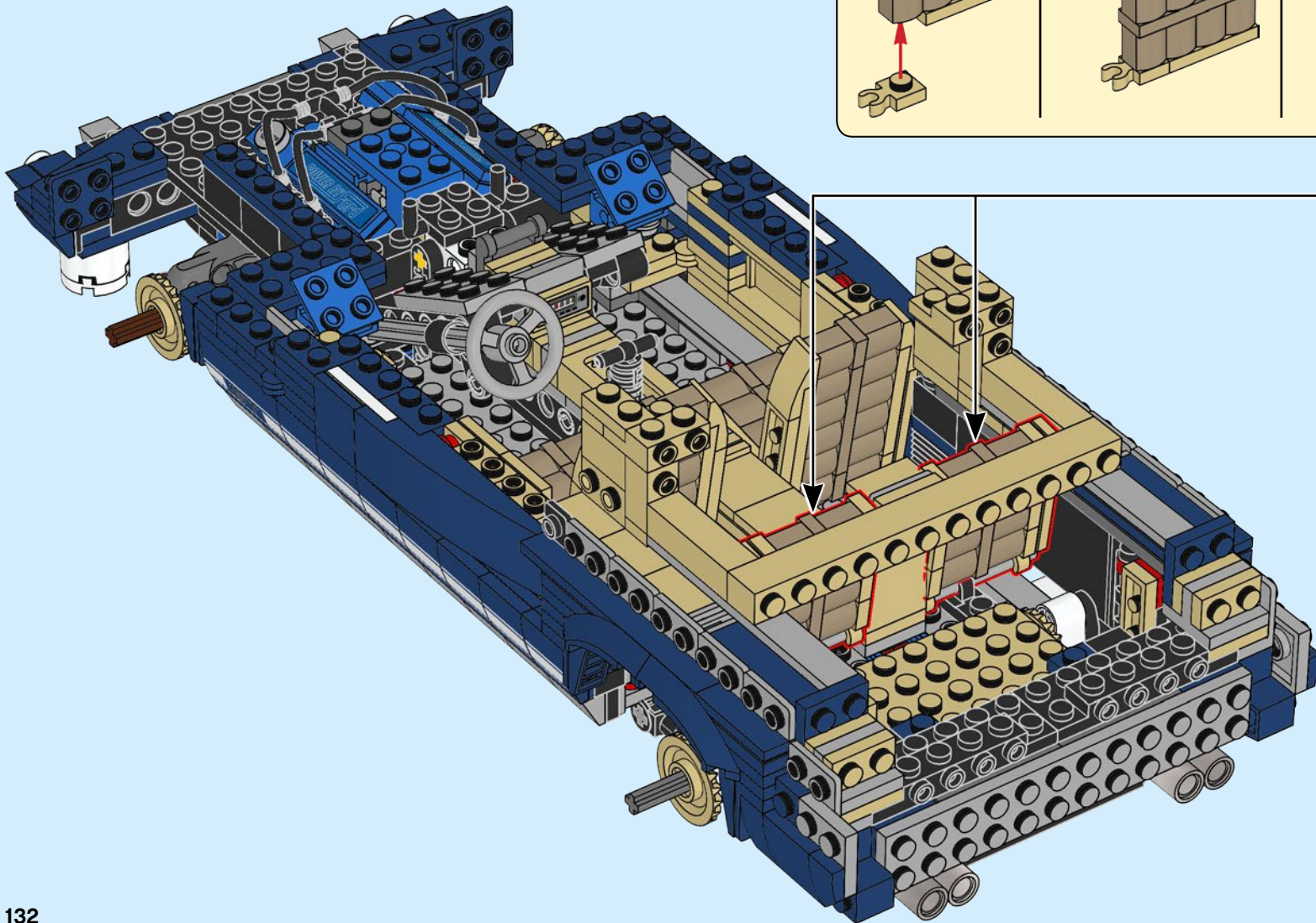
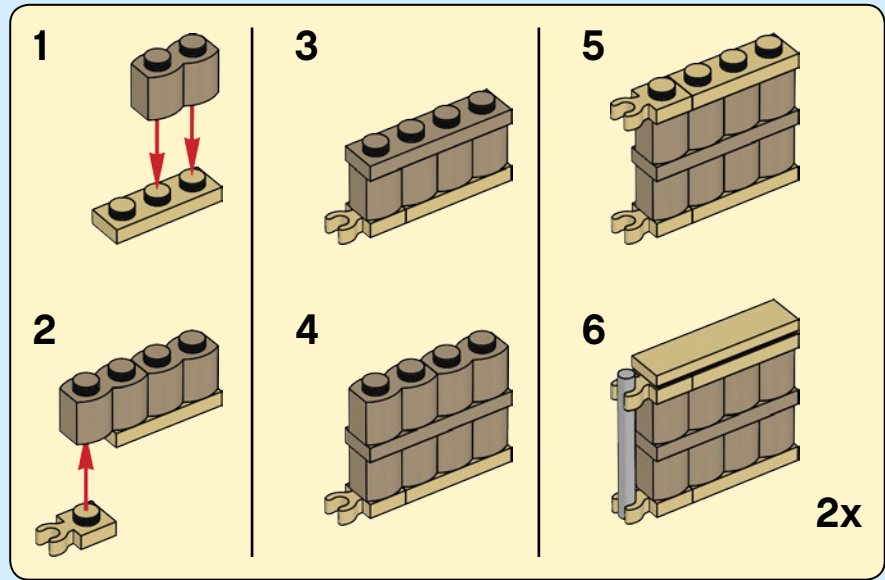

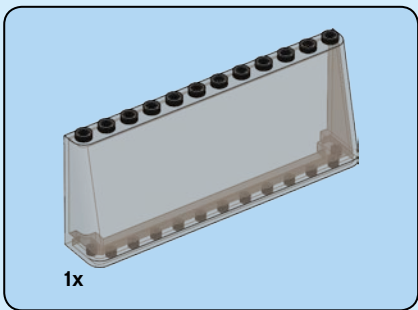

204

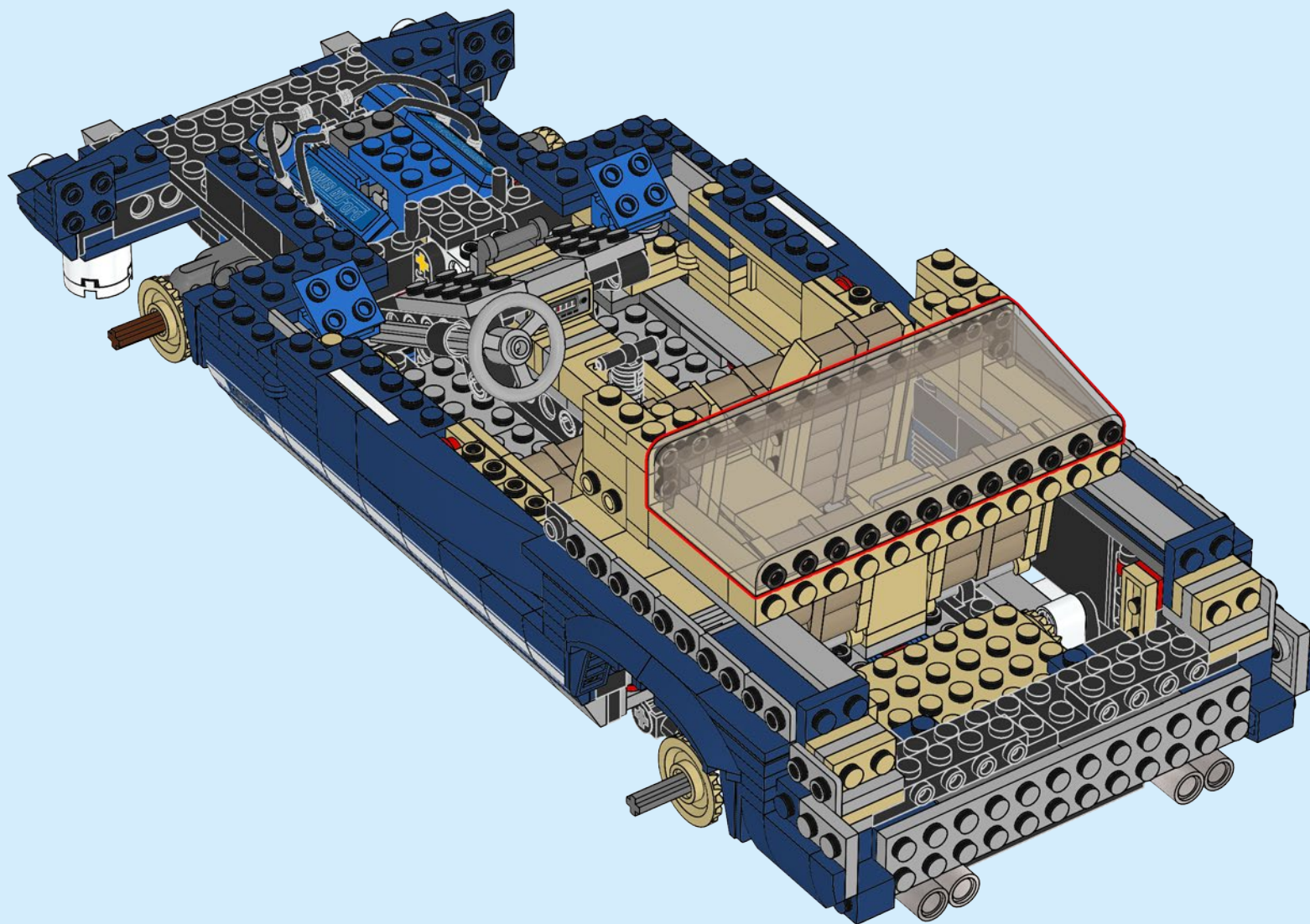



2x



4x

205

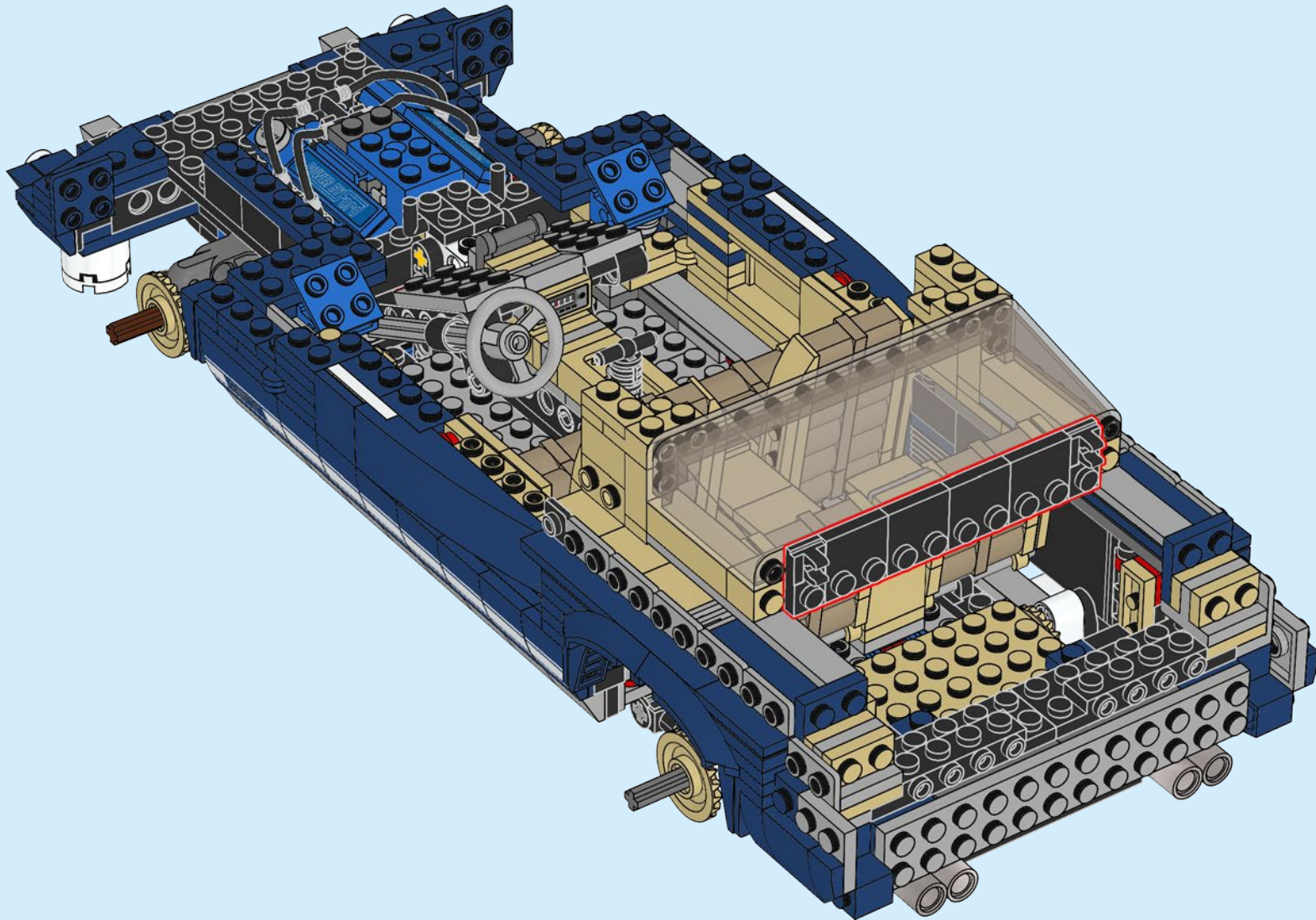

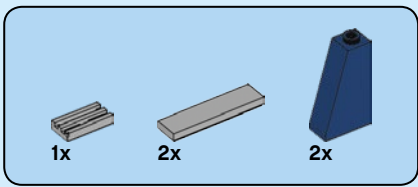

206

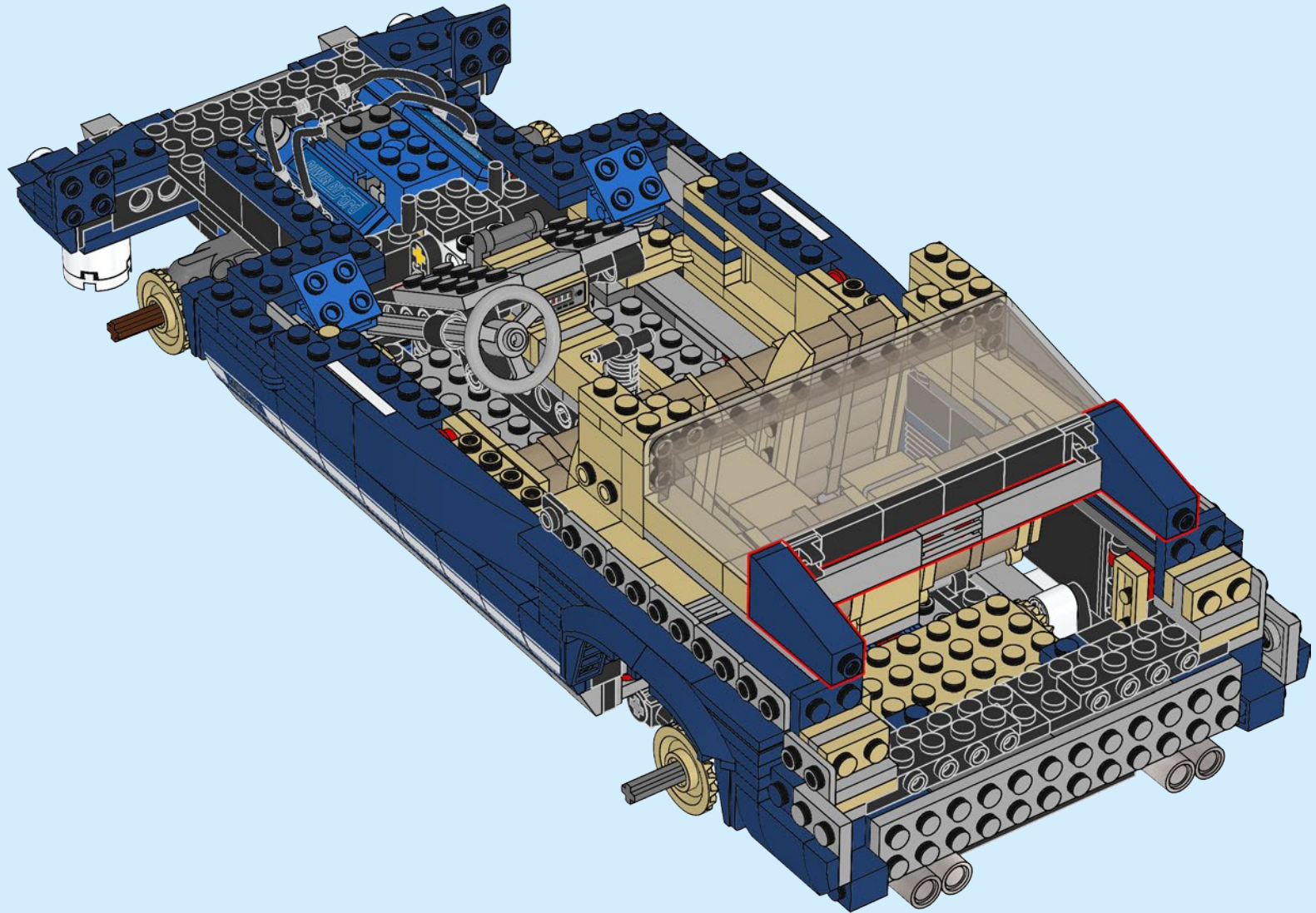

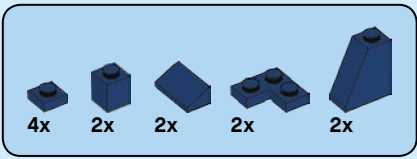

207

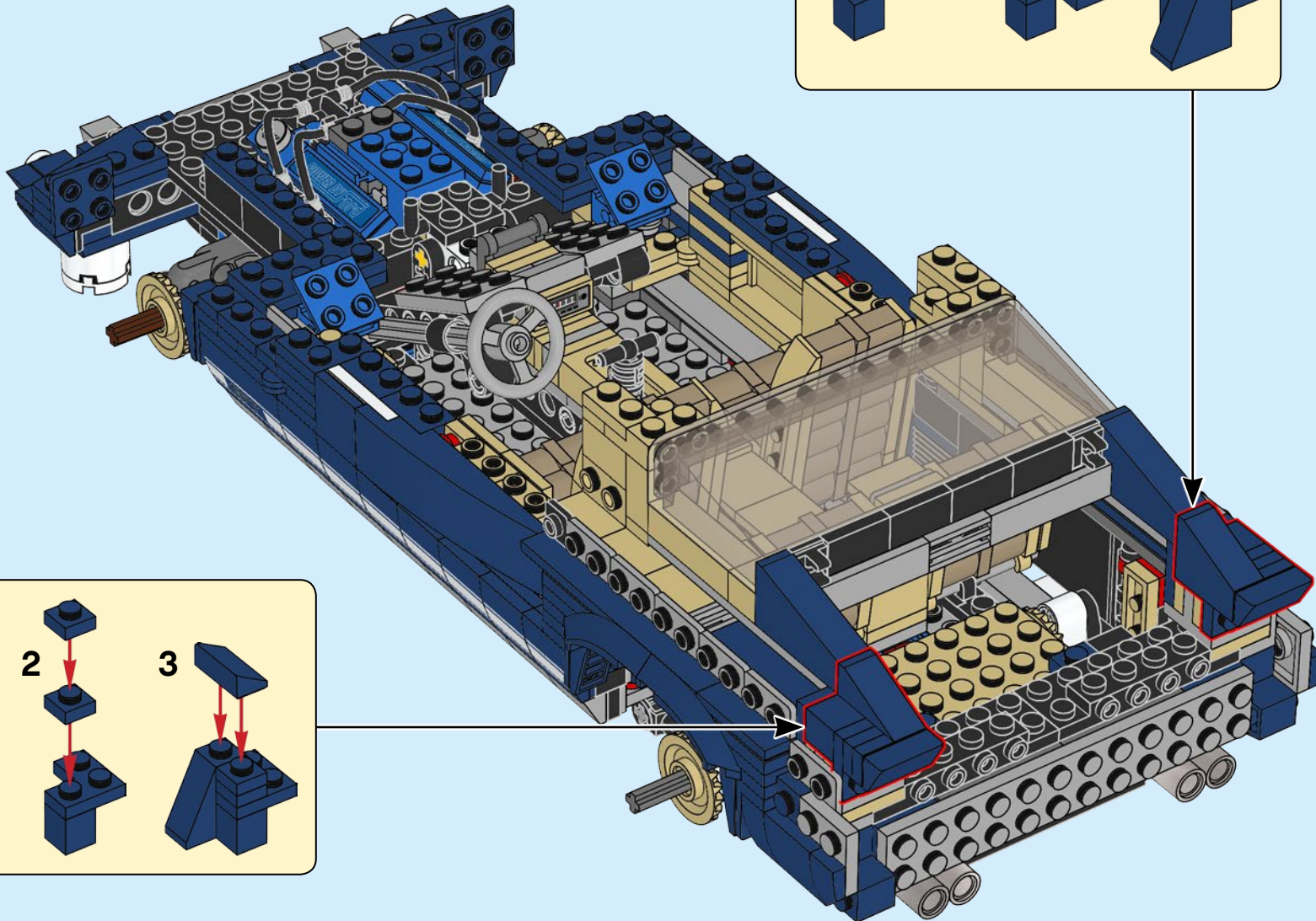
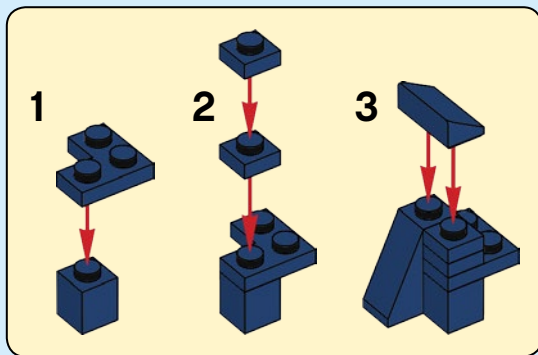
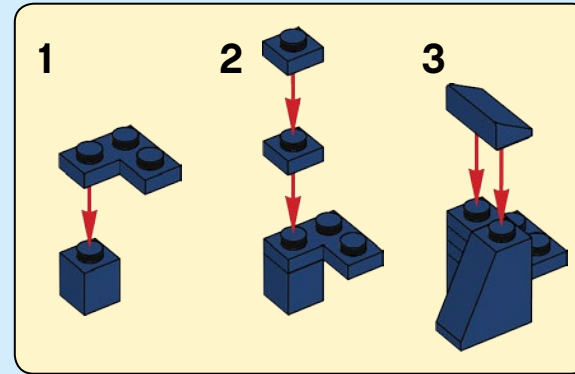

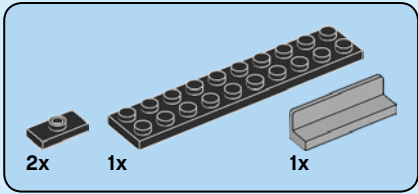
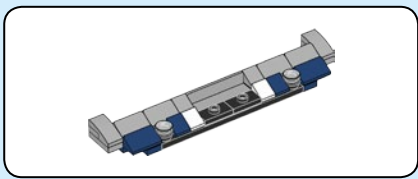

208

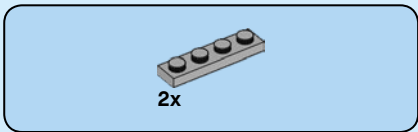
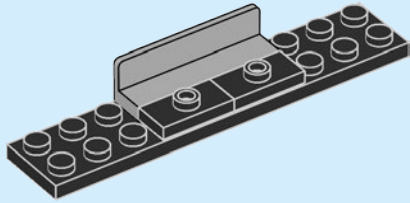

209

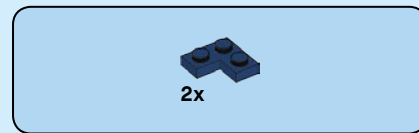
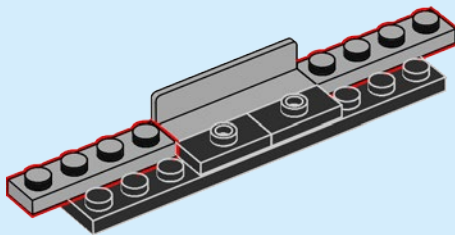

210

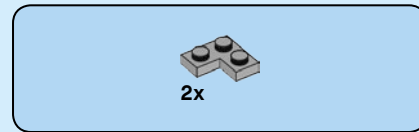
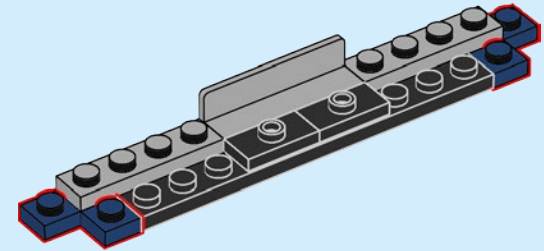

211

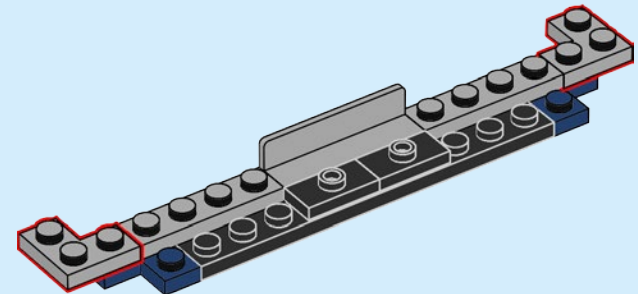

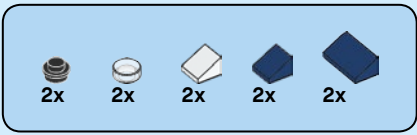

212

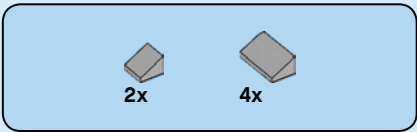
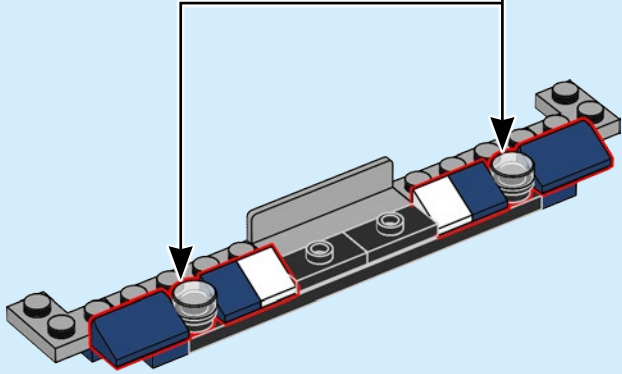
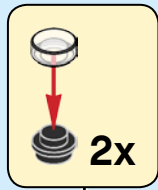

213

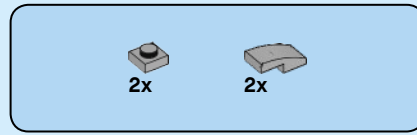
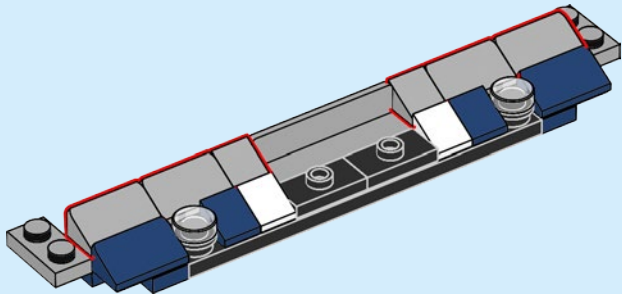

214

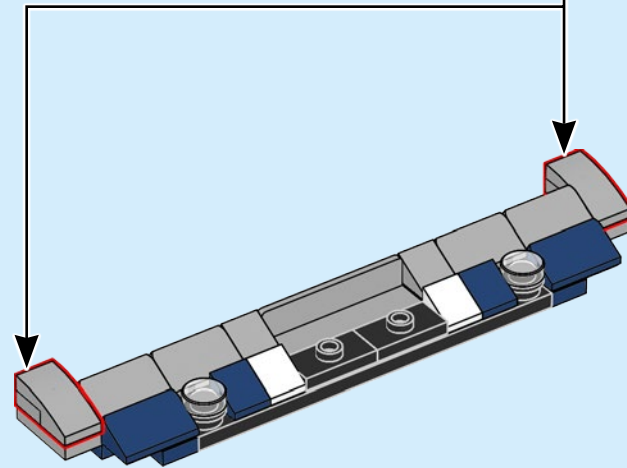
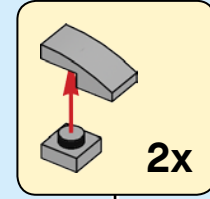

215

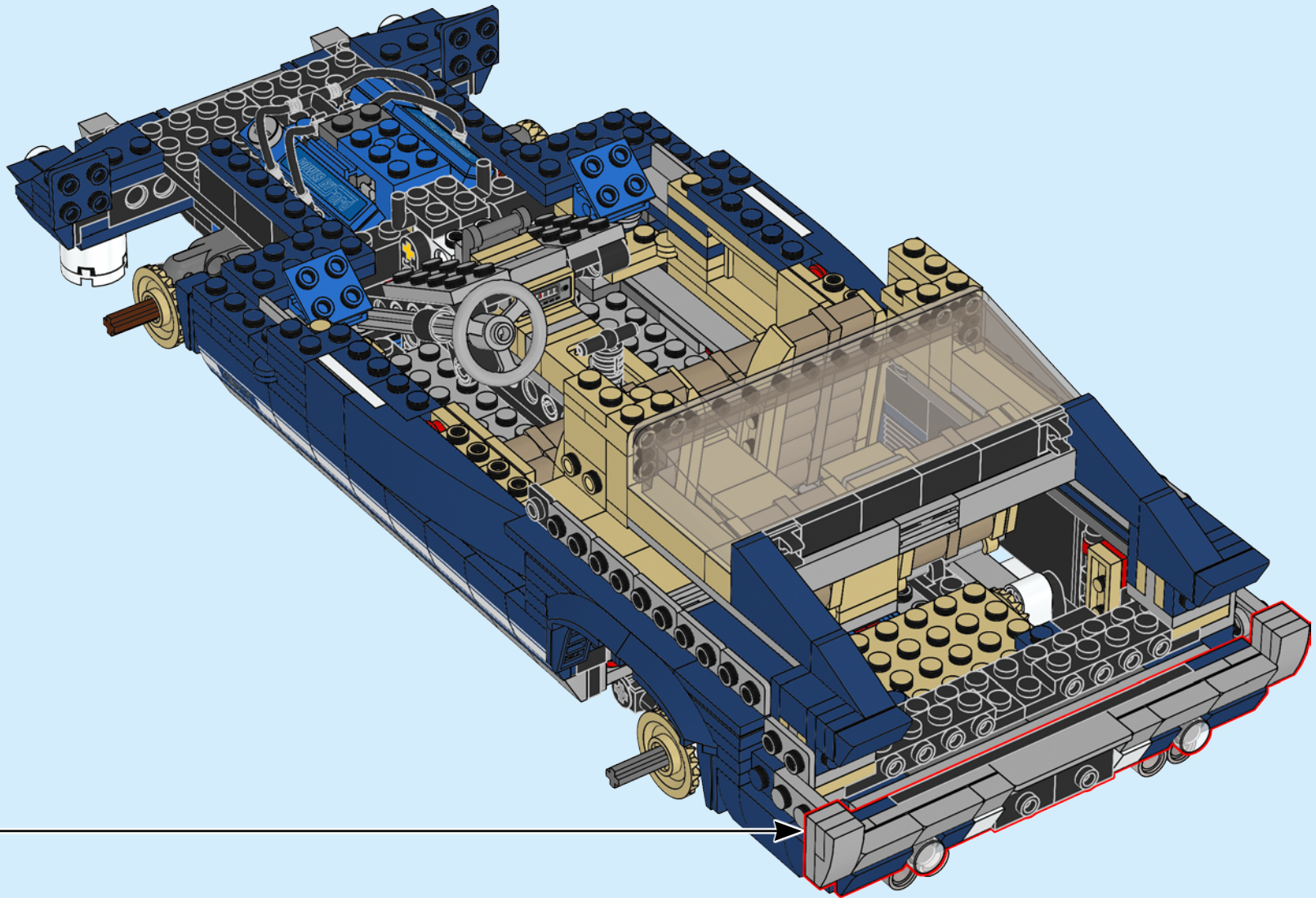

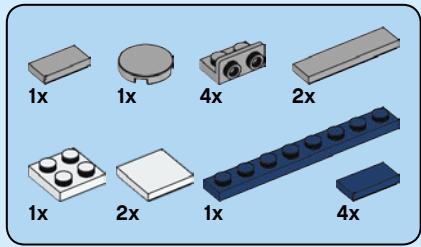

216

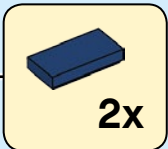
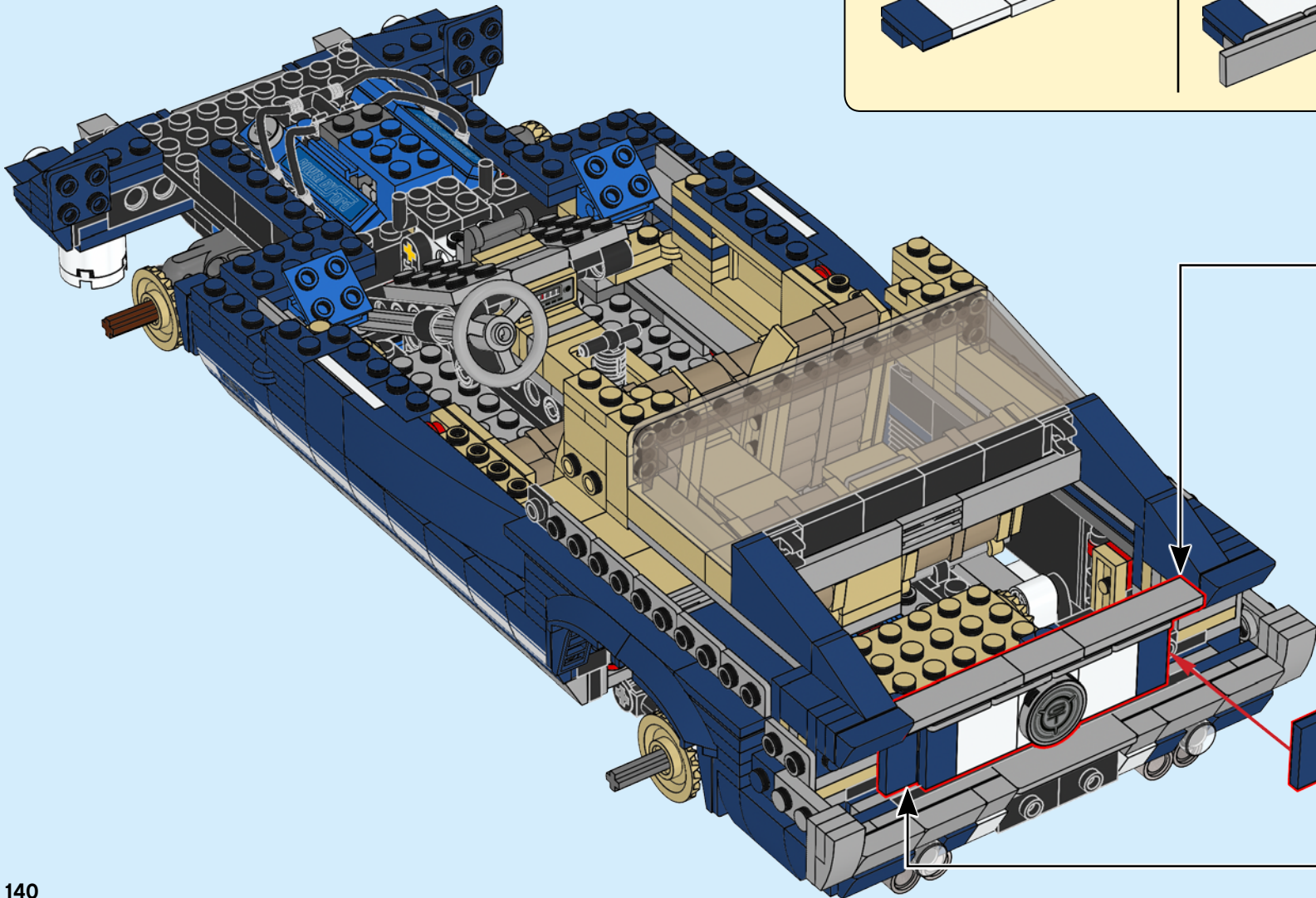
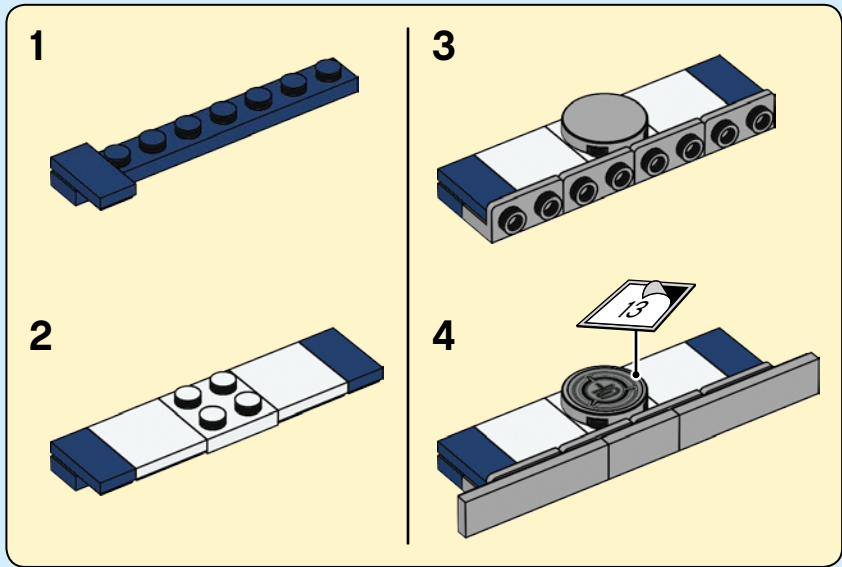

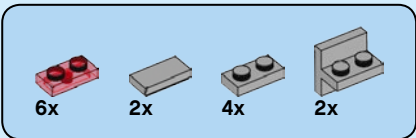

217

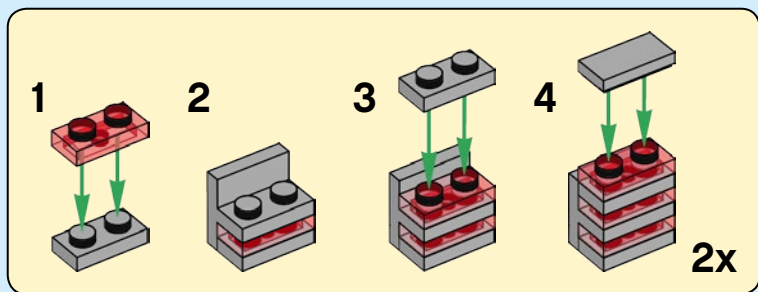
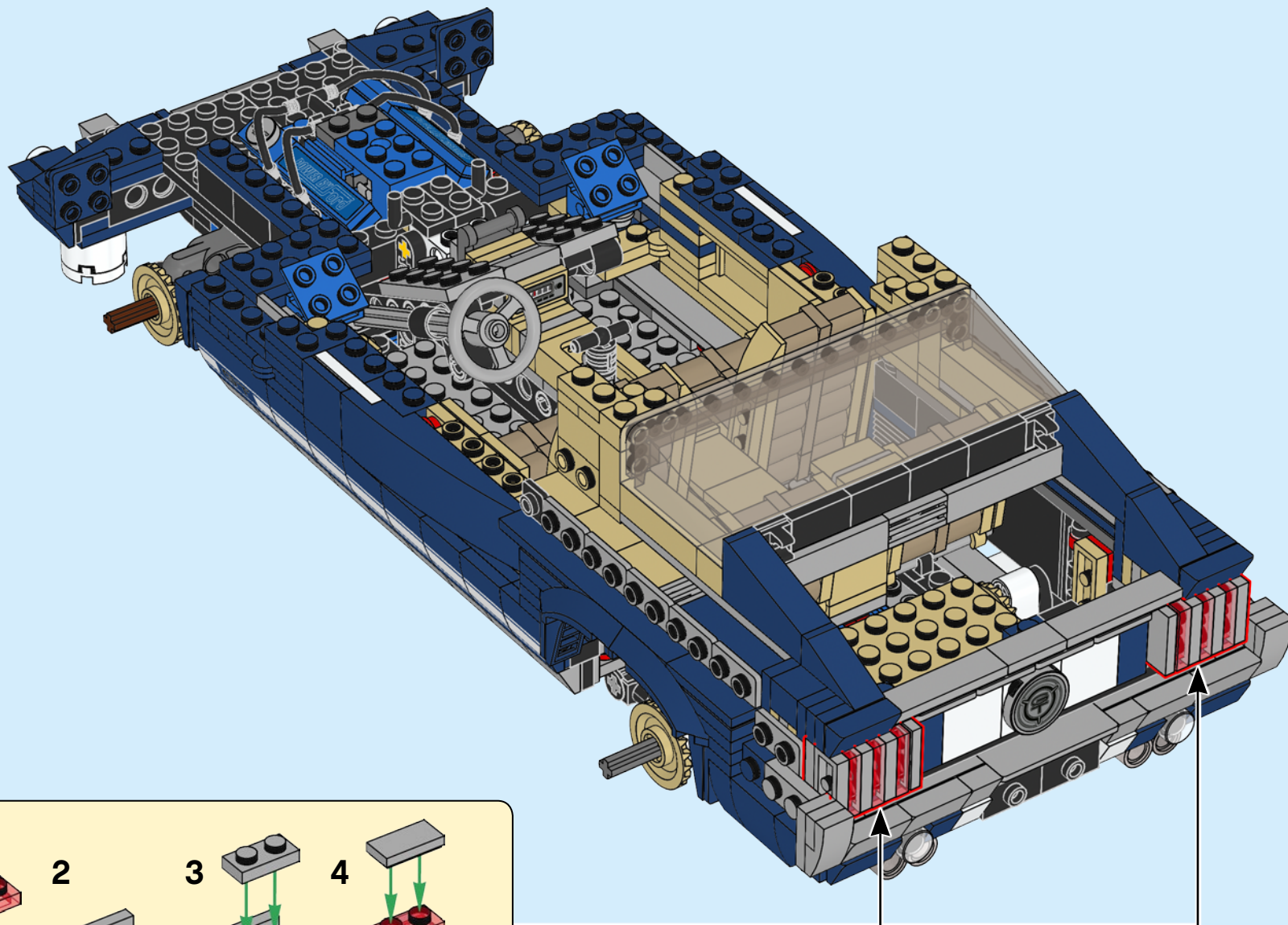

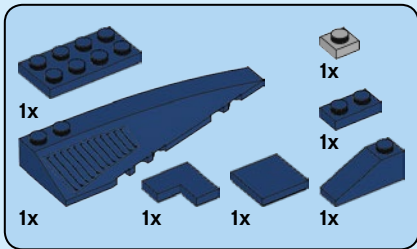

218

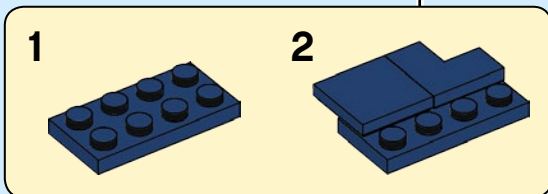
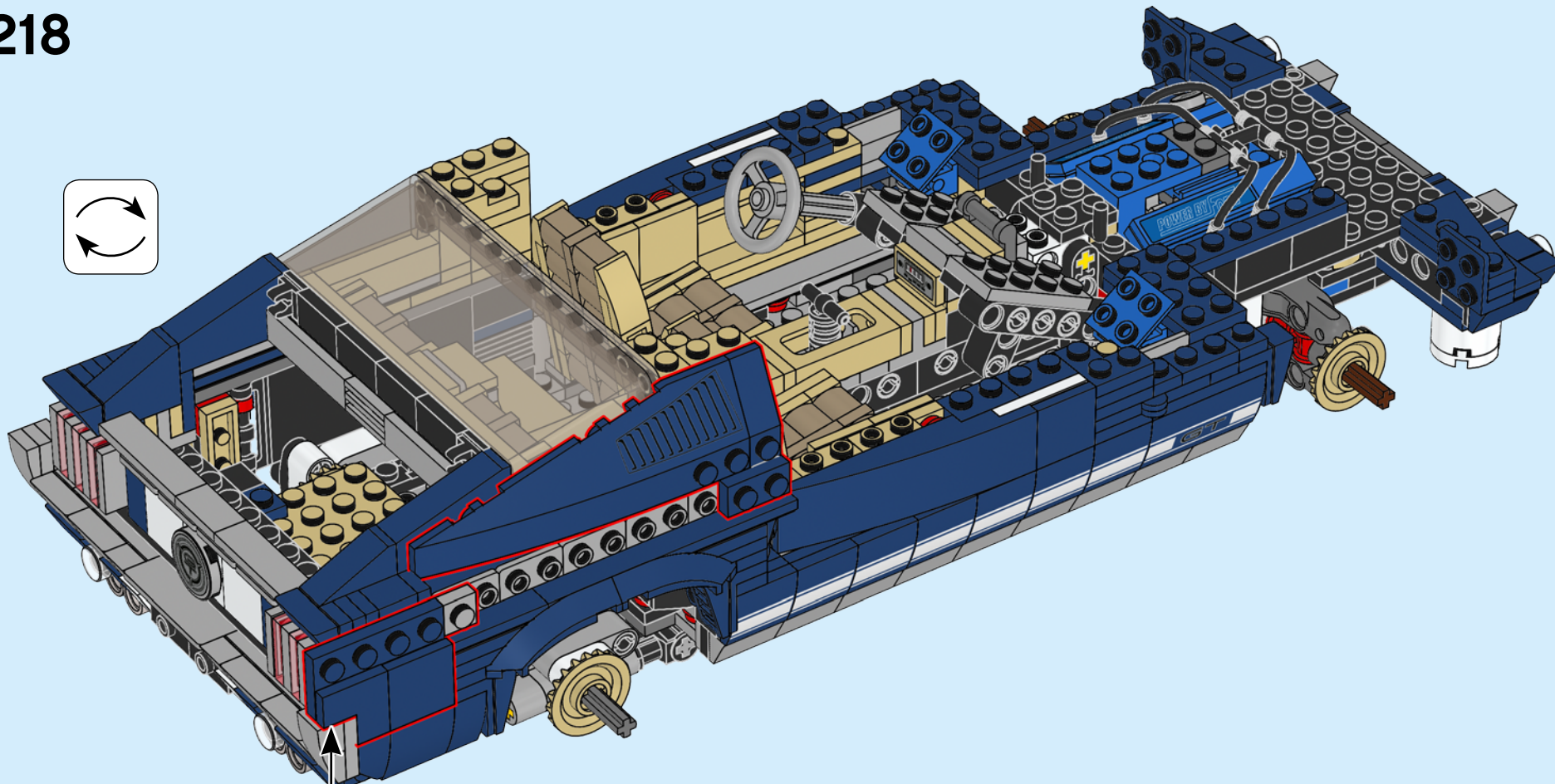
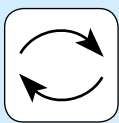

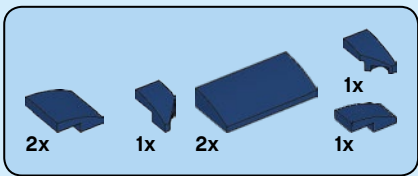

219

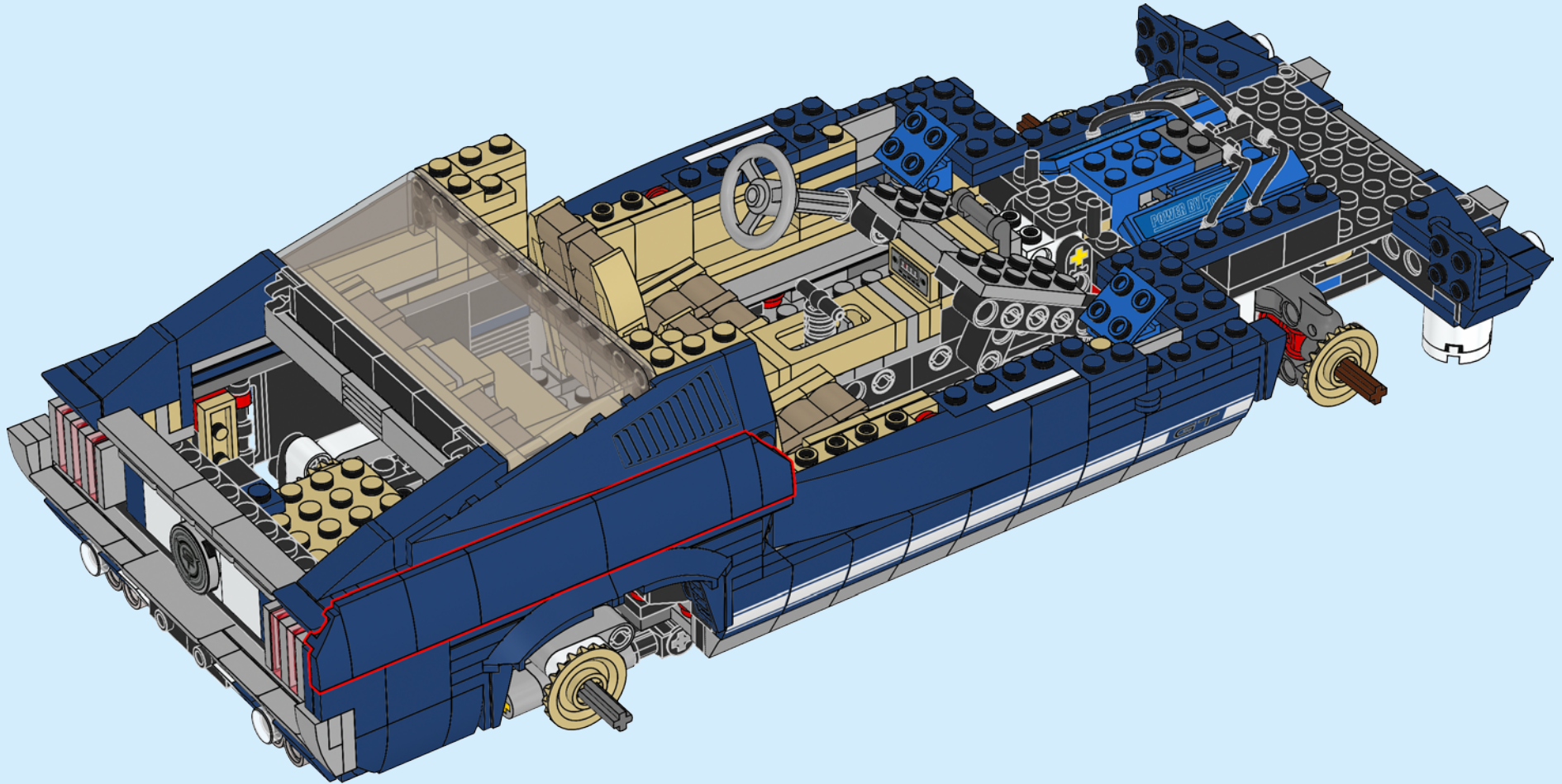

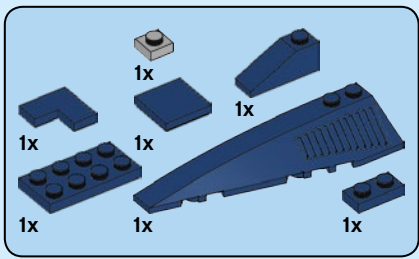

220

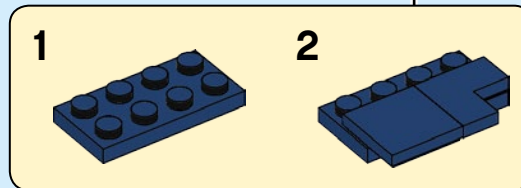
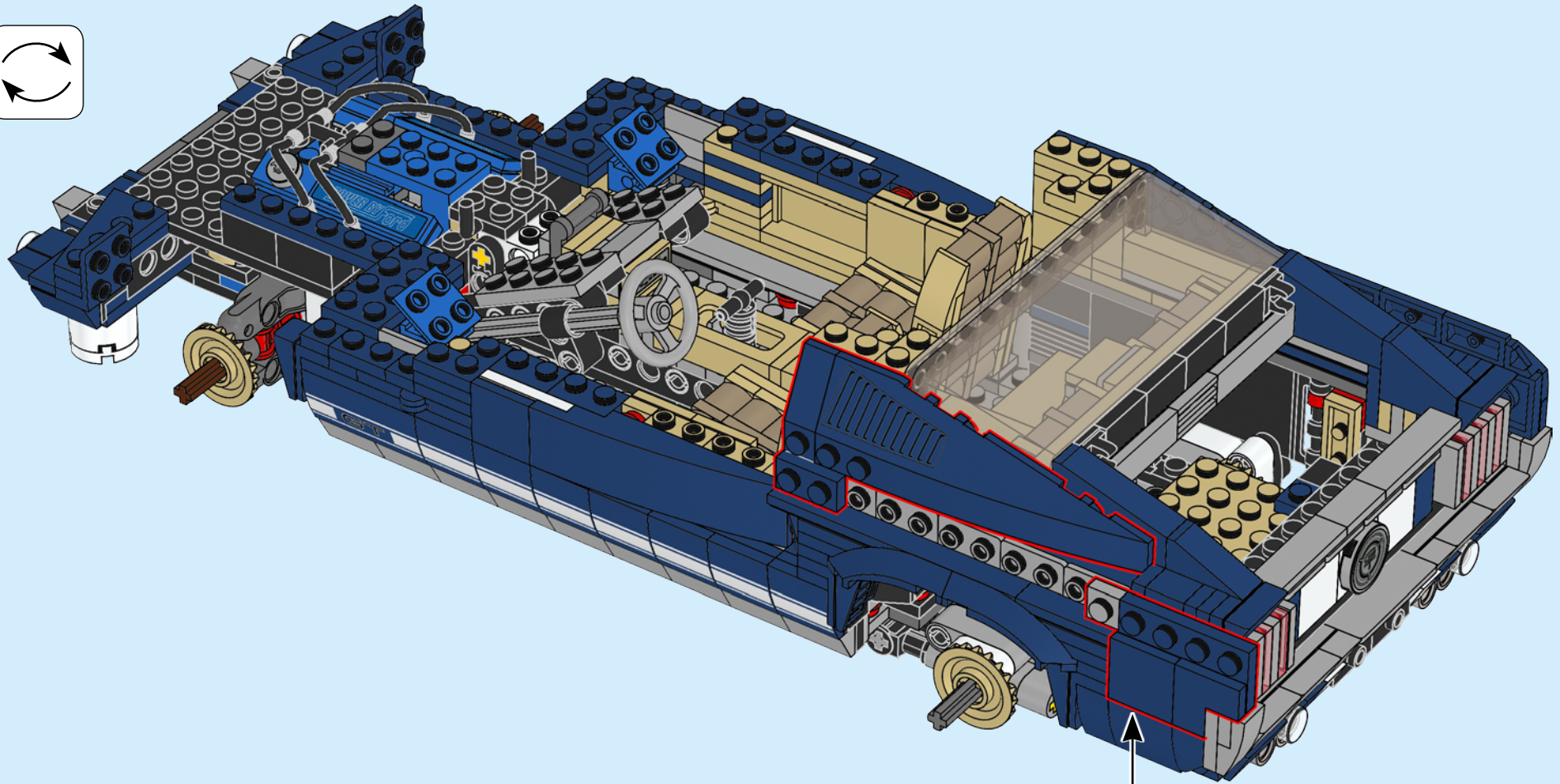
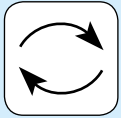

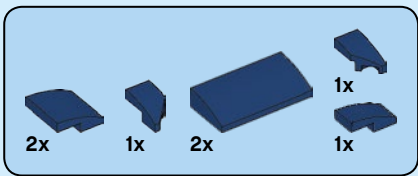

221

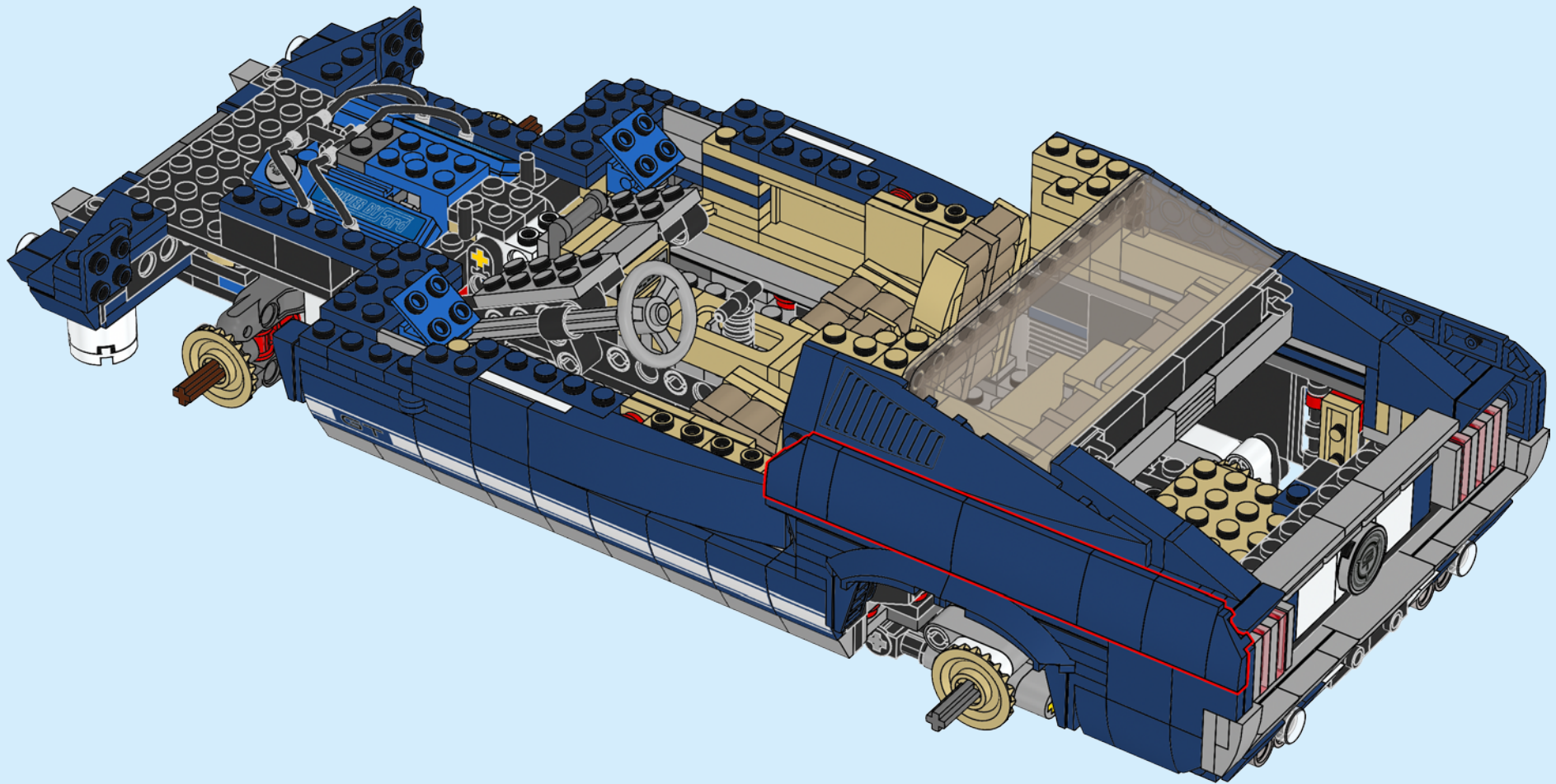

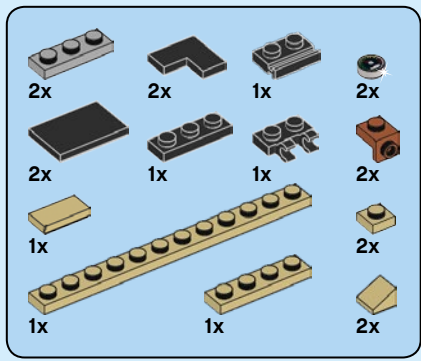

222

1

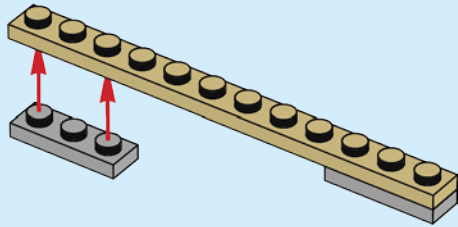

2

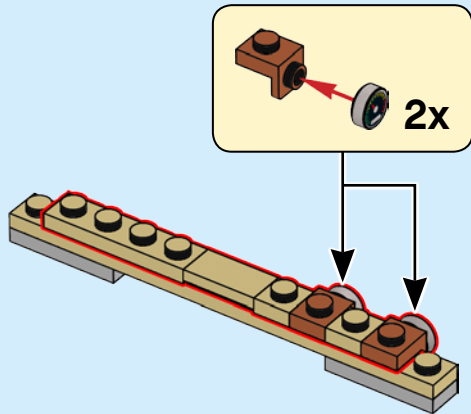

3

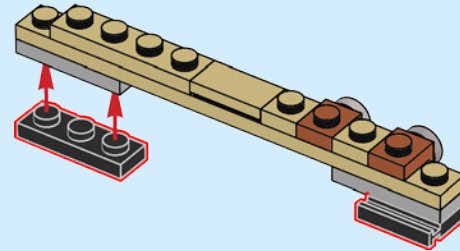

4

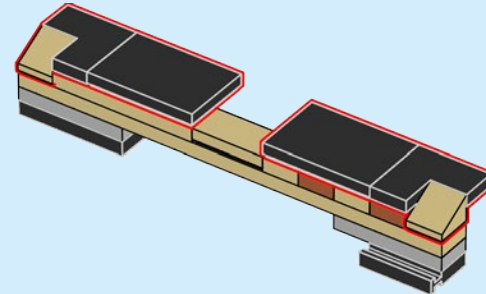

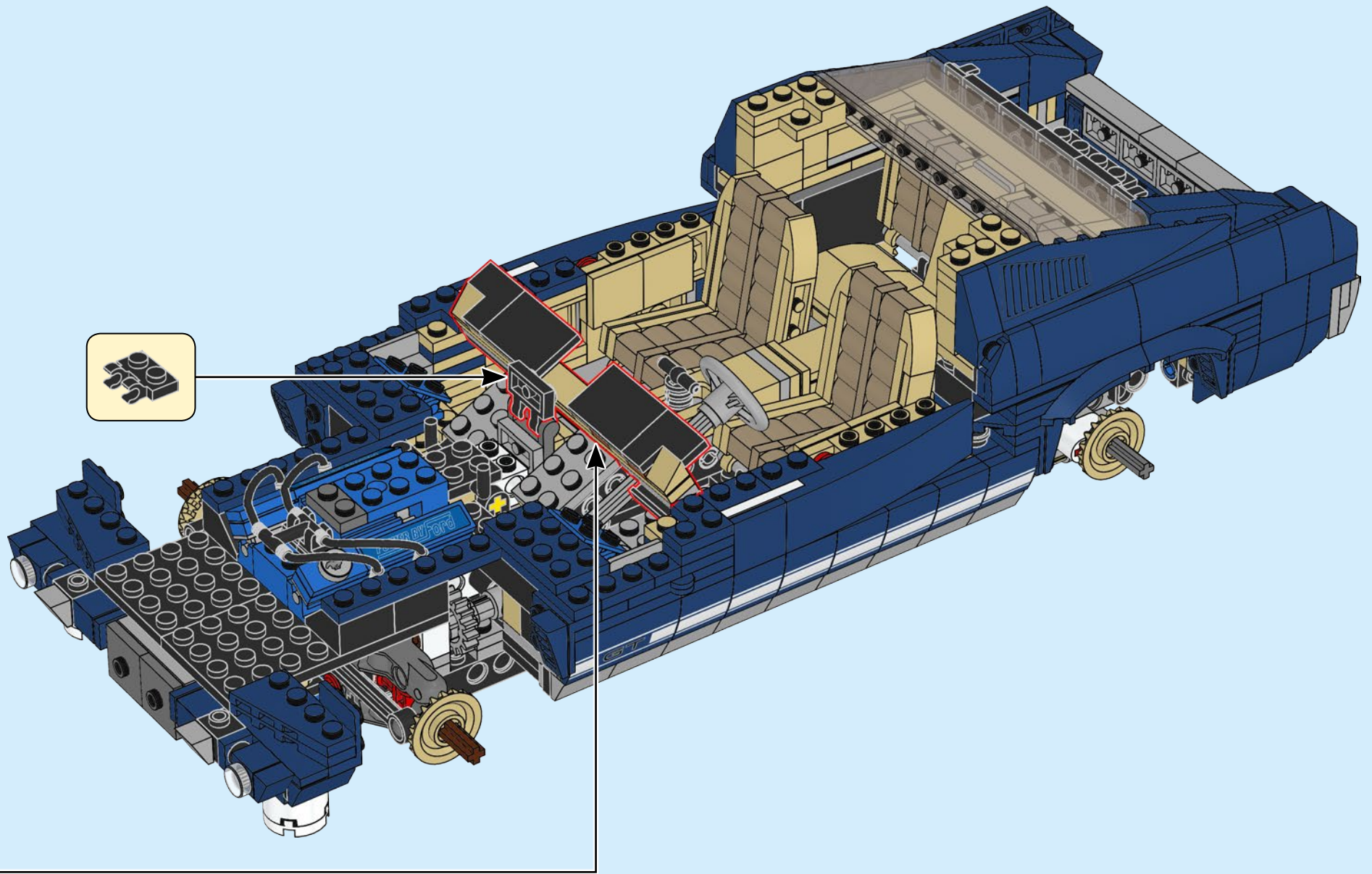

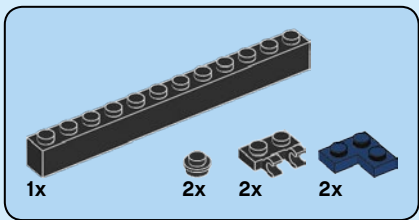

223

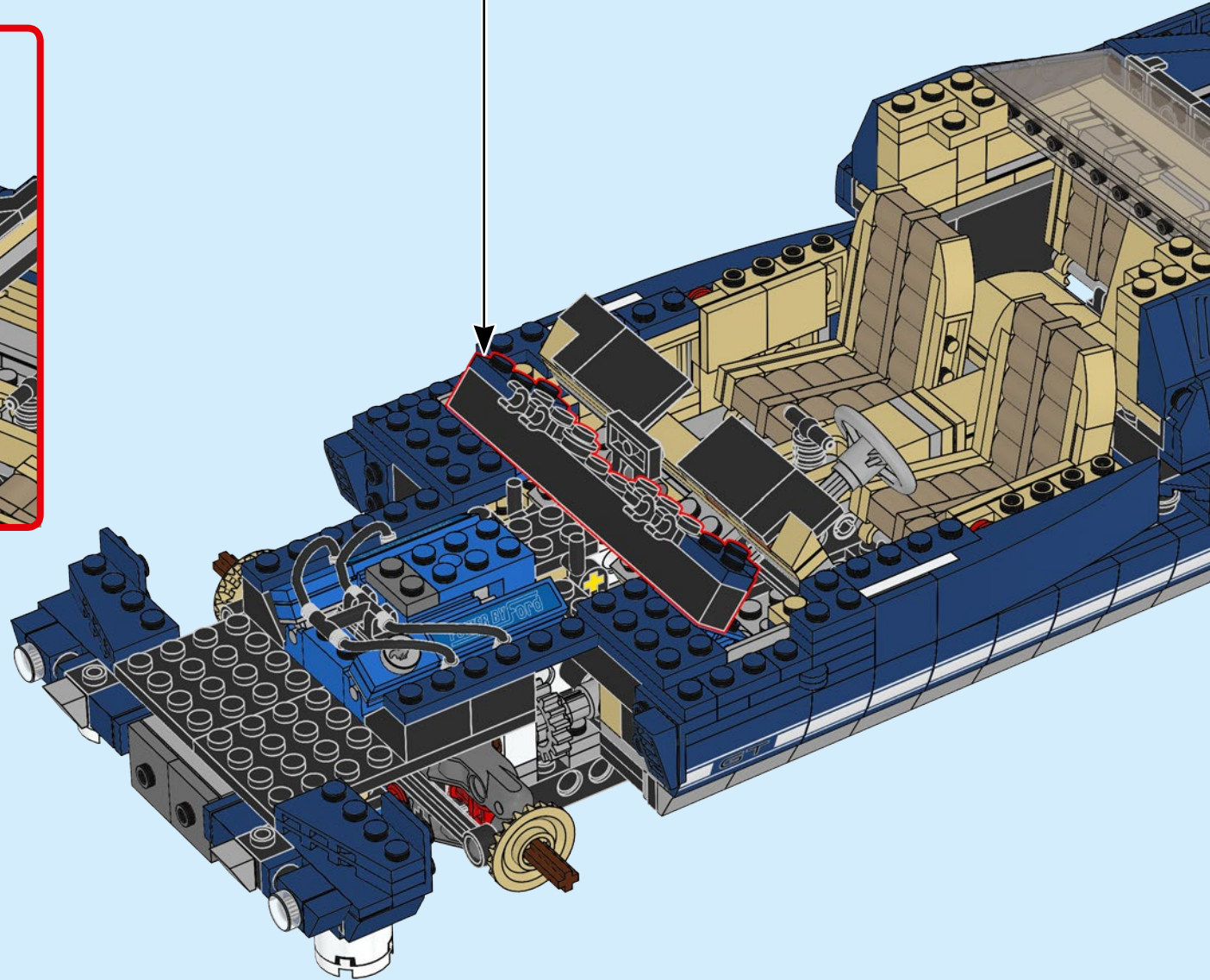
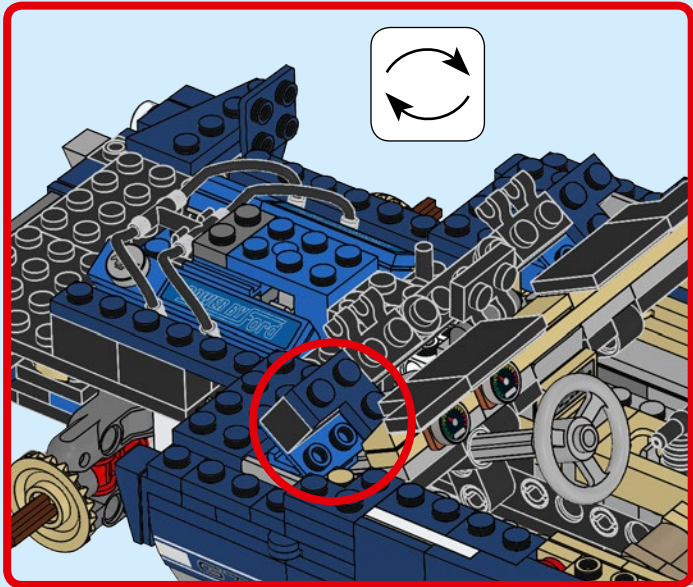
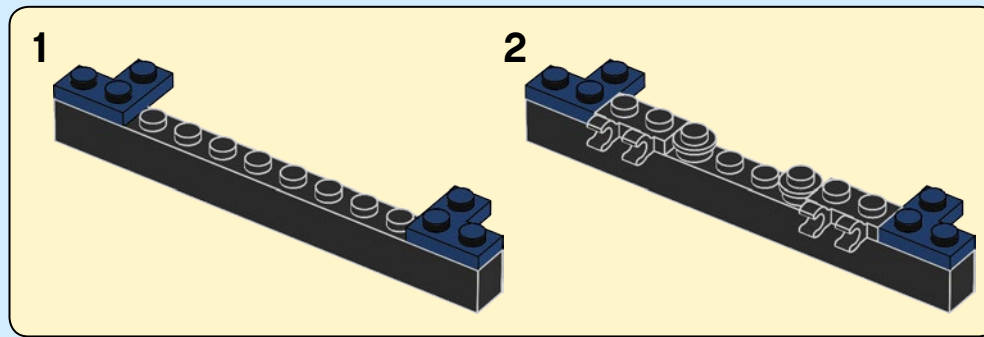

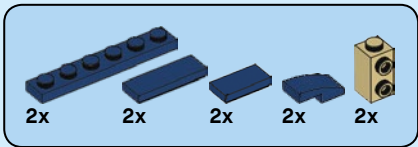

224

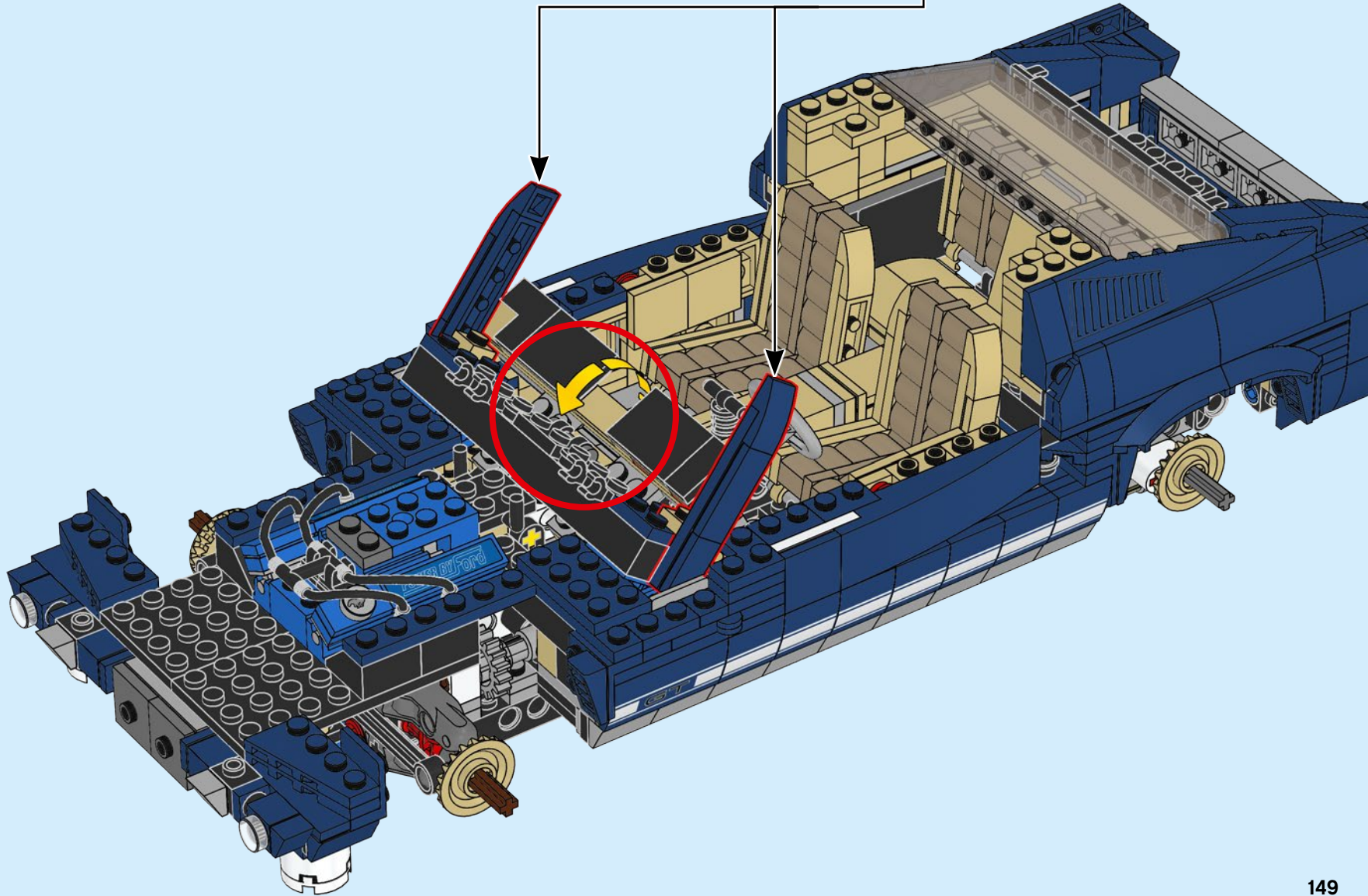
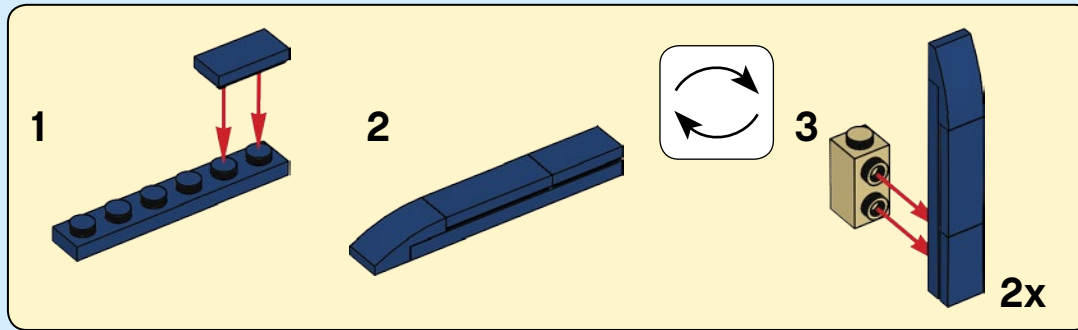

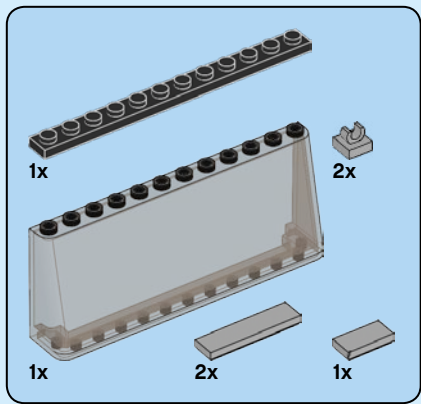

225

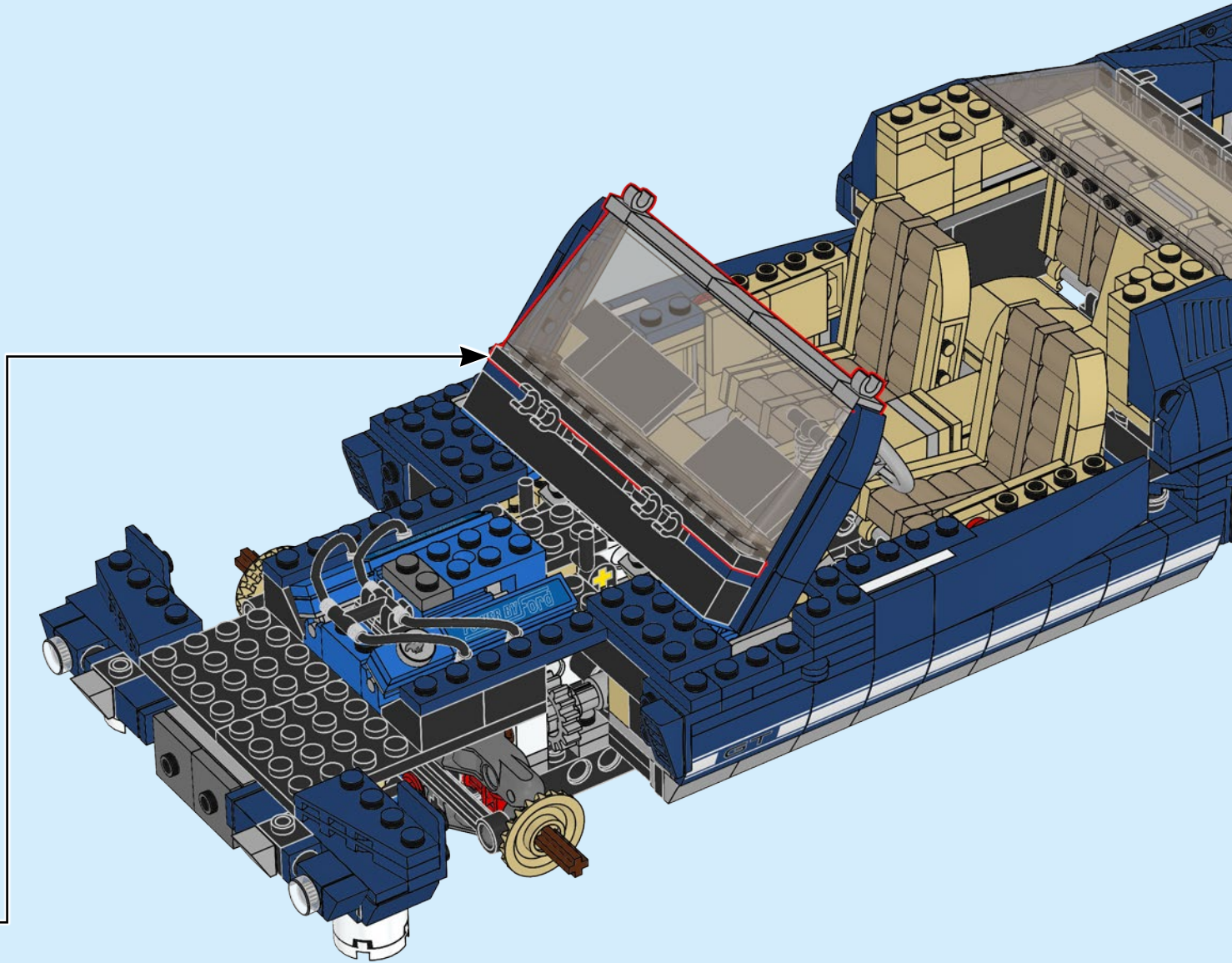
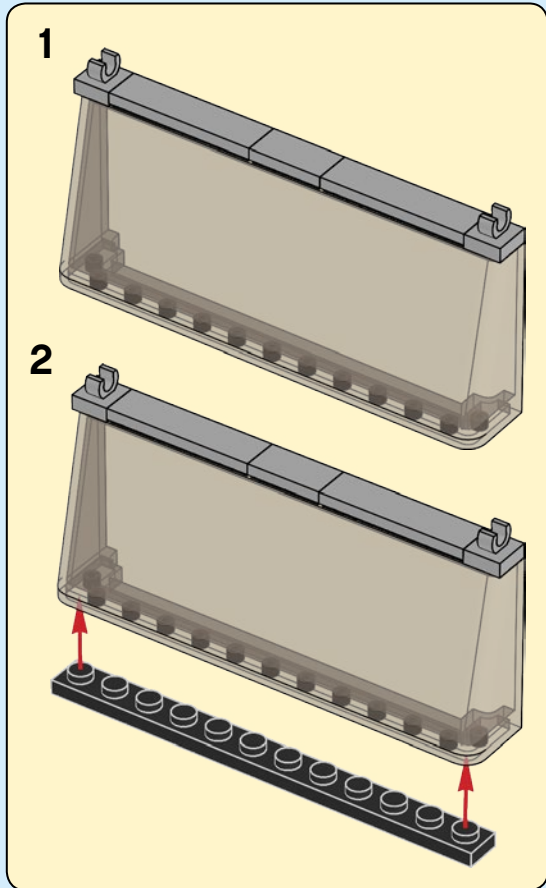

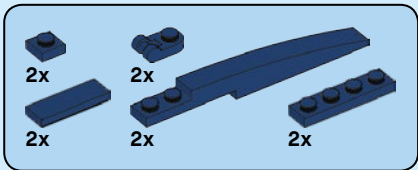

226

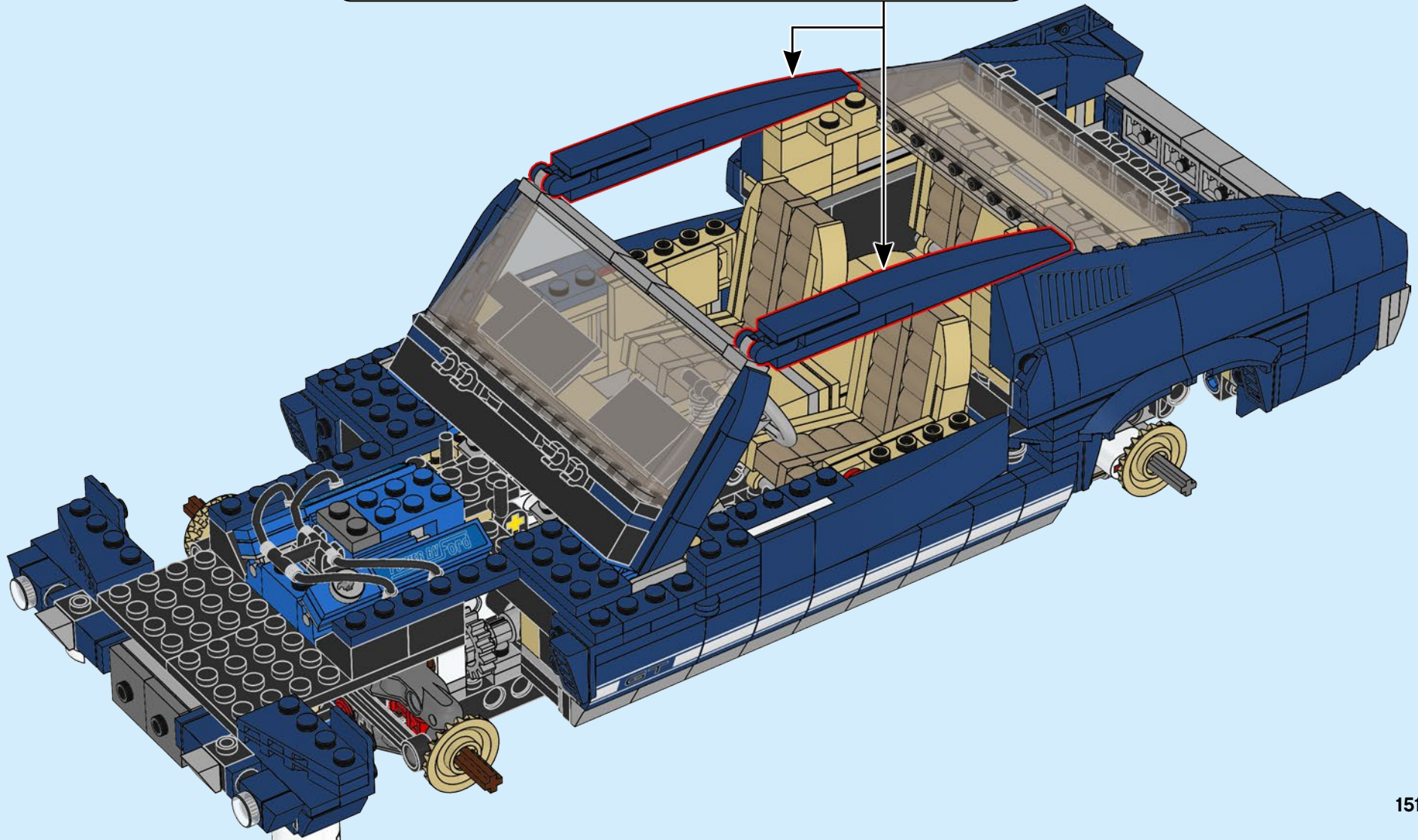
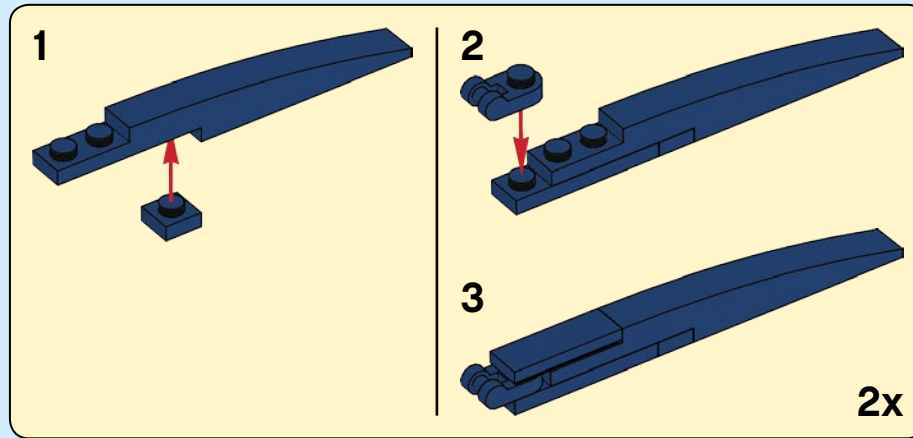

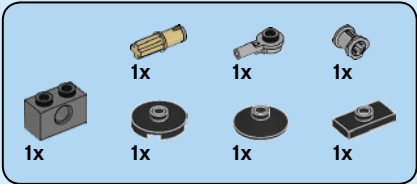
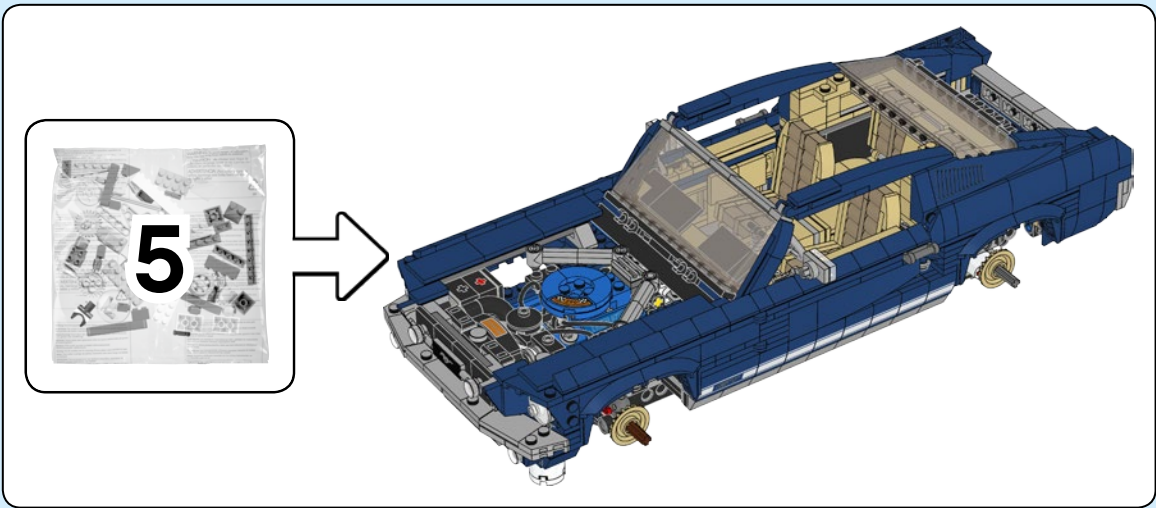

227

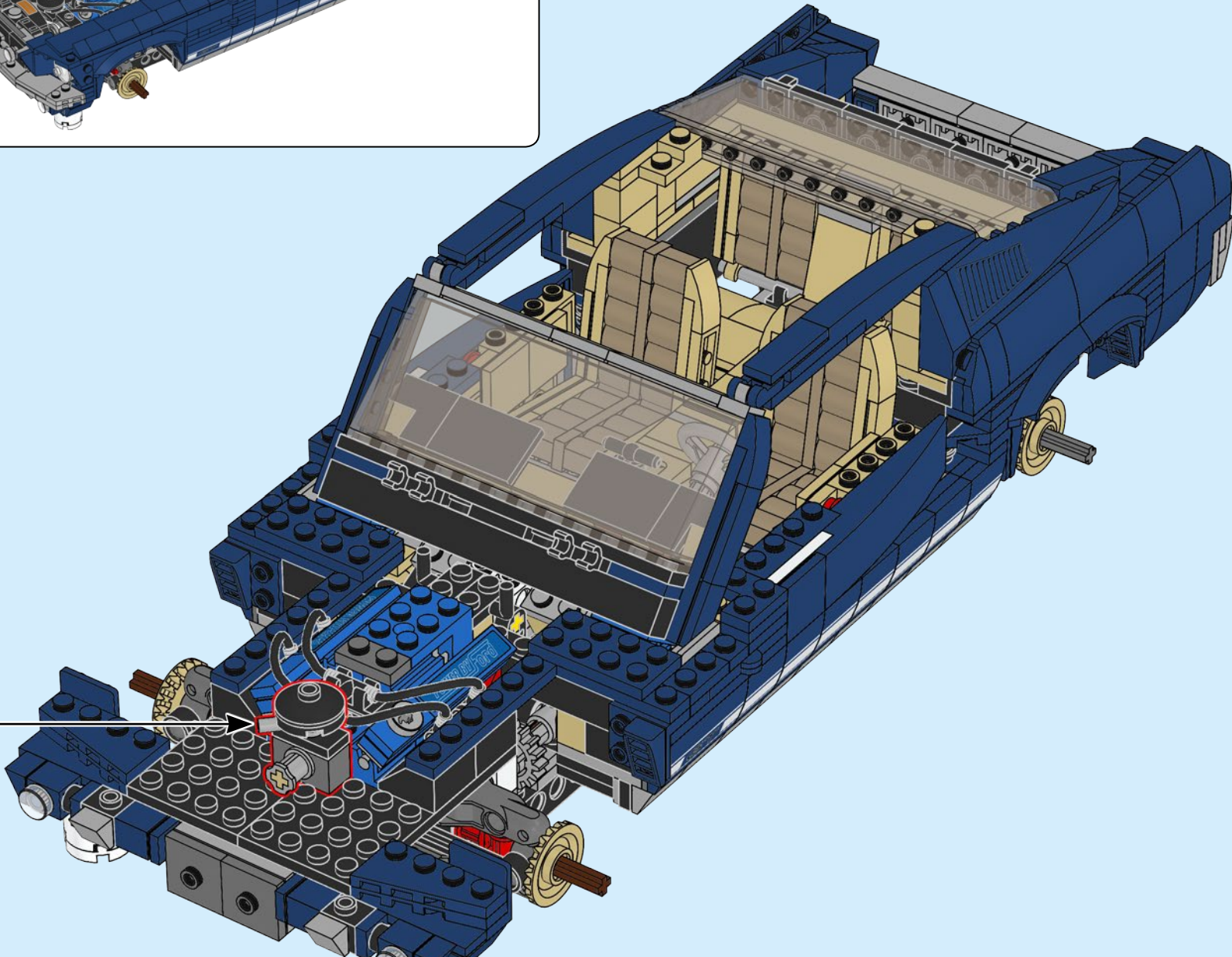
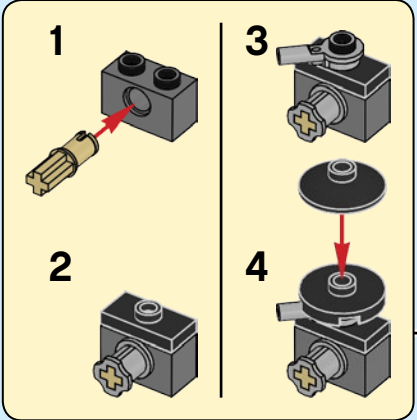

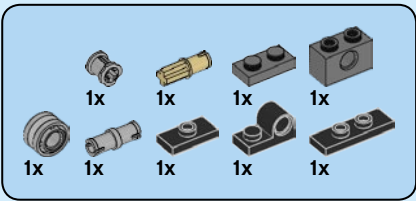

228

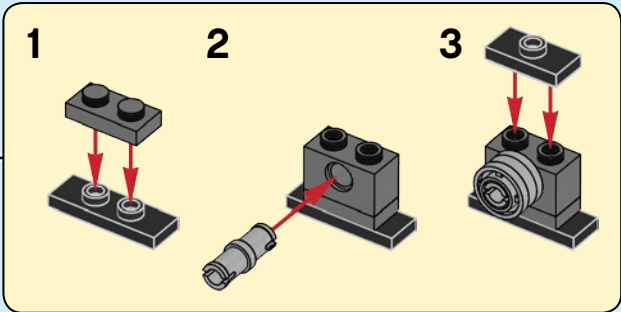
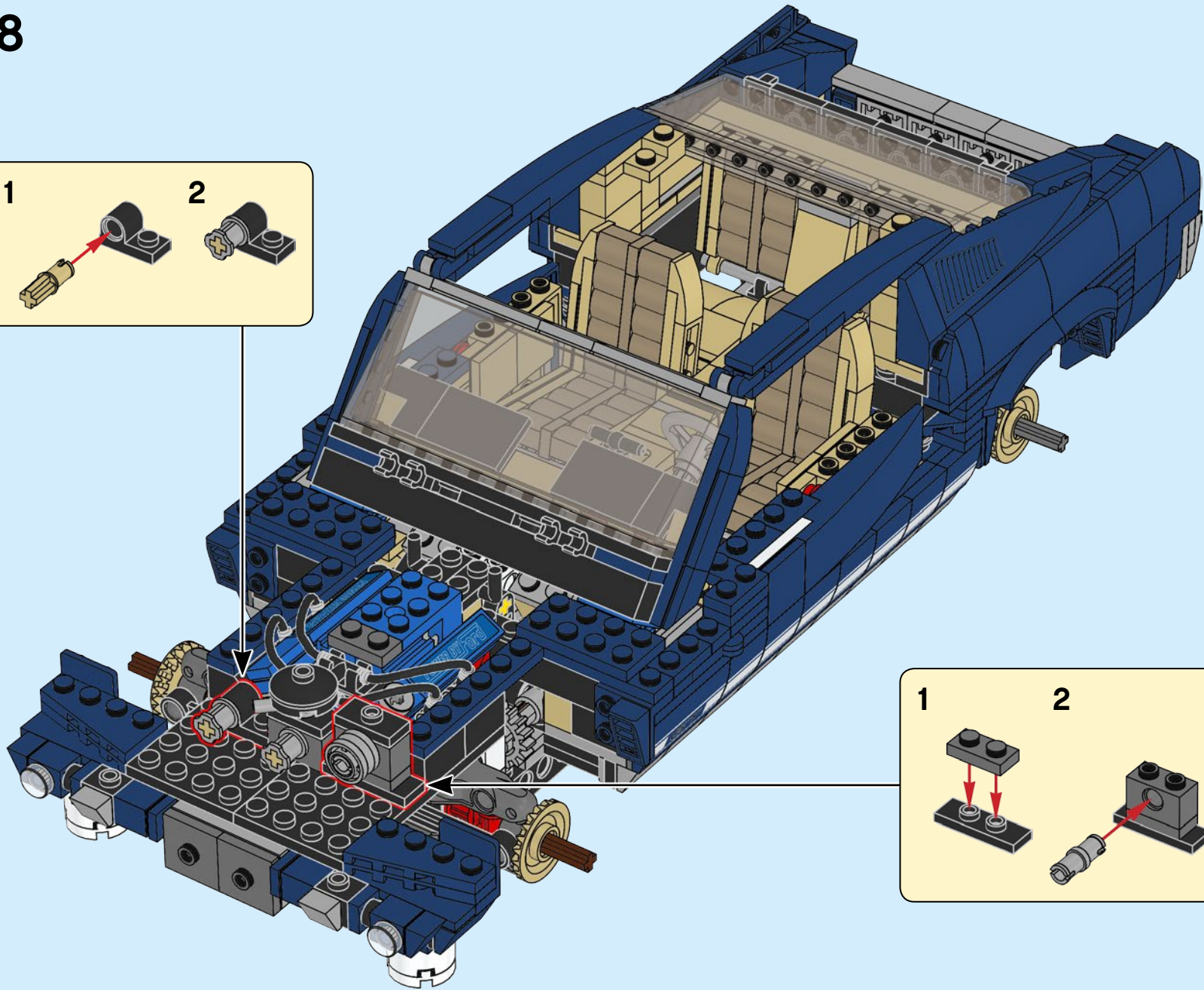
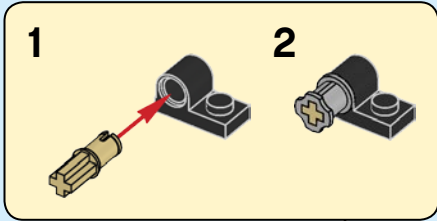



2x

229

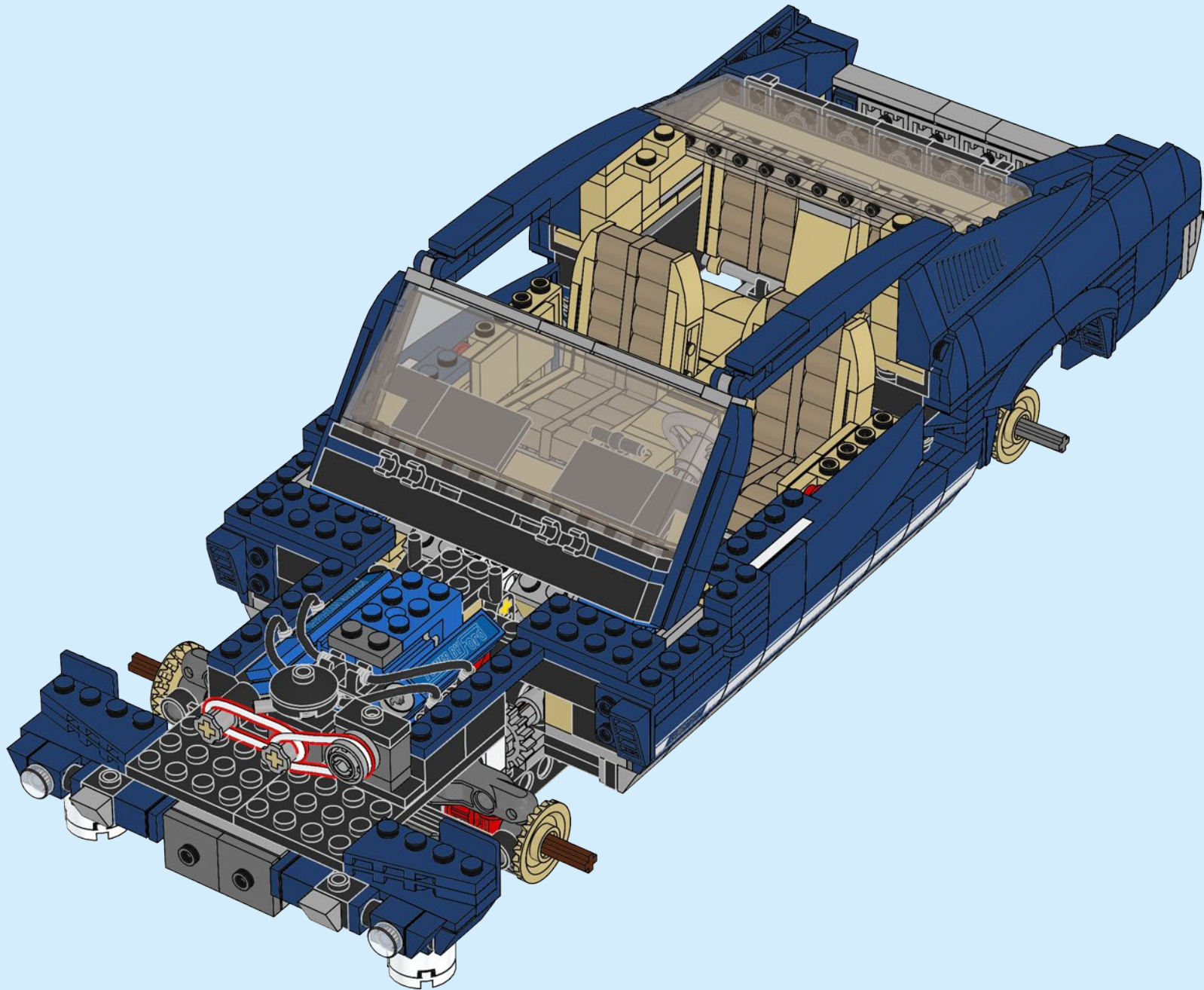

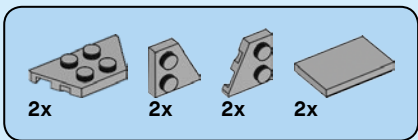

230

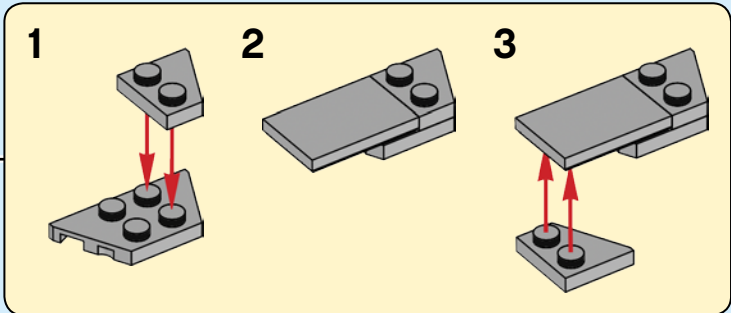
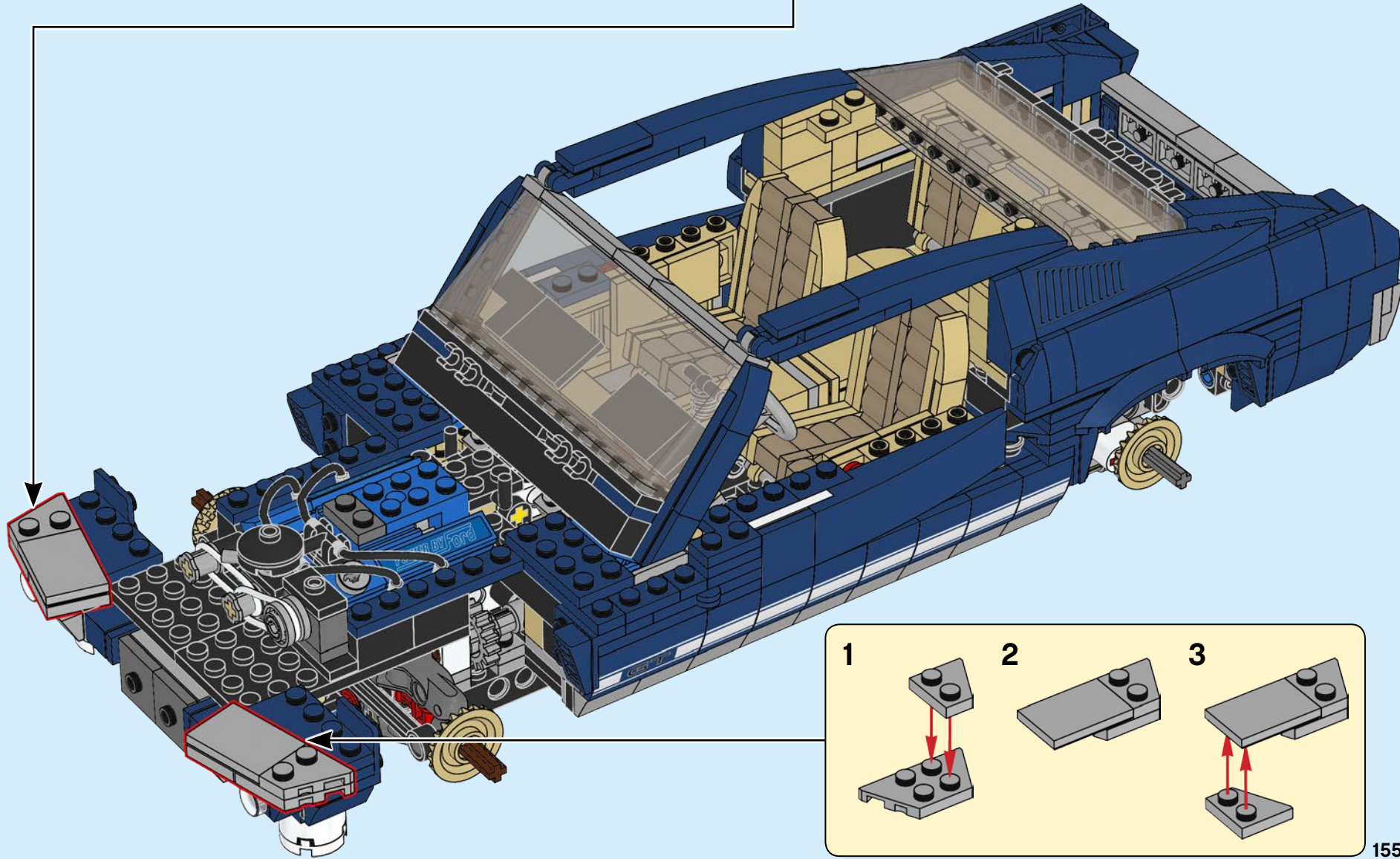
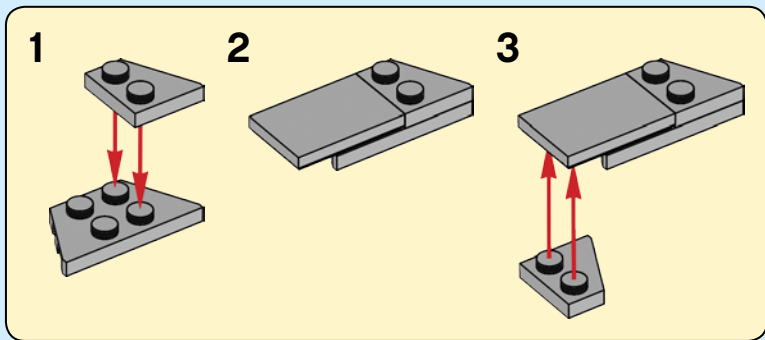

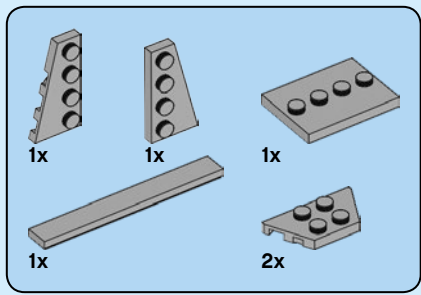

231

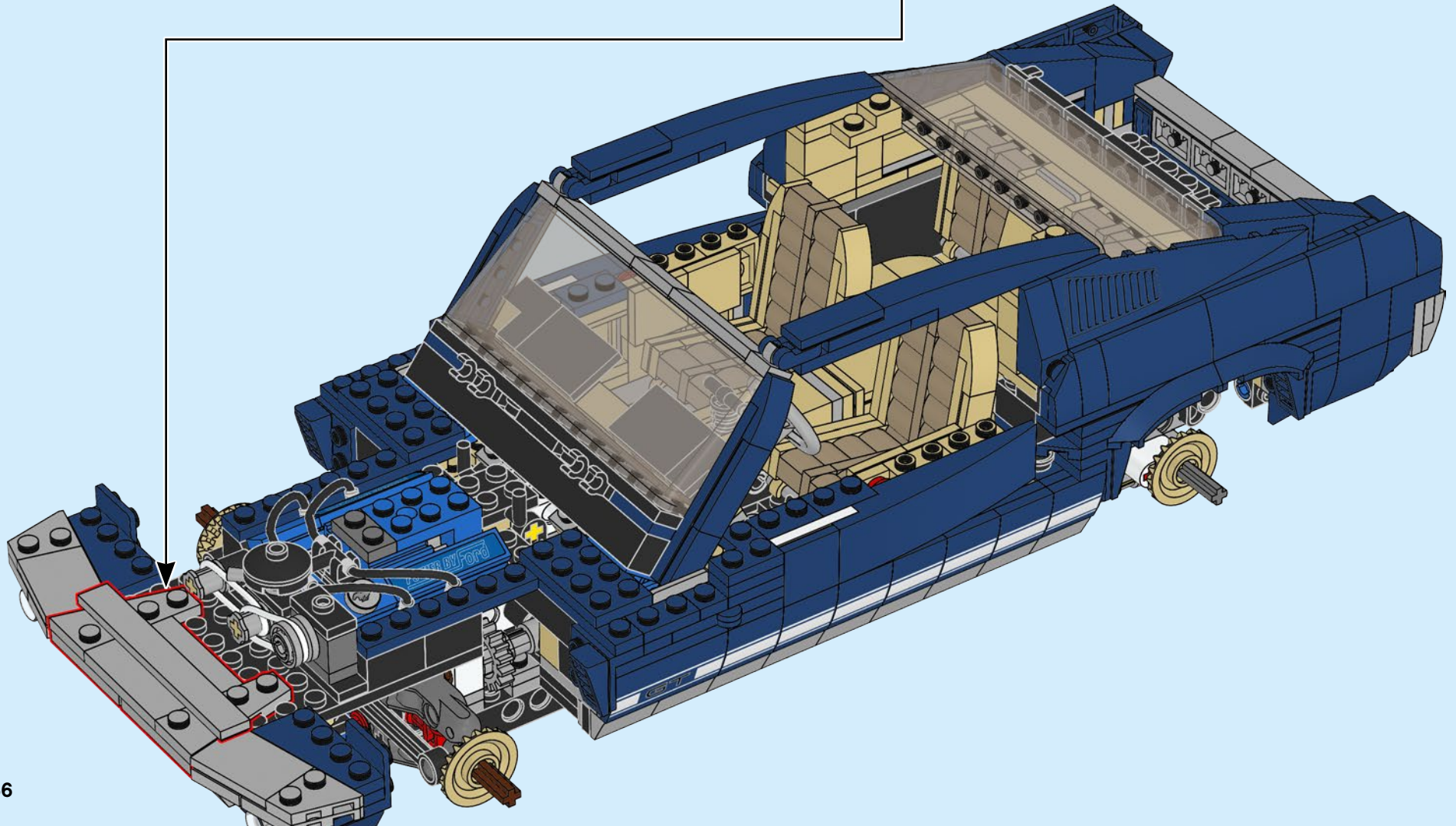
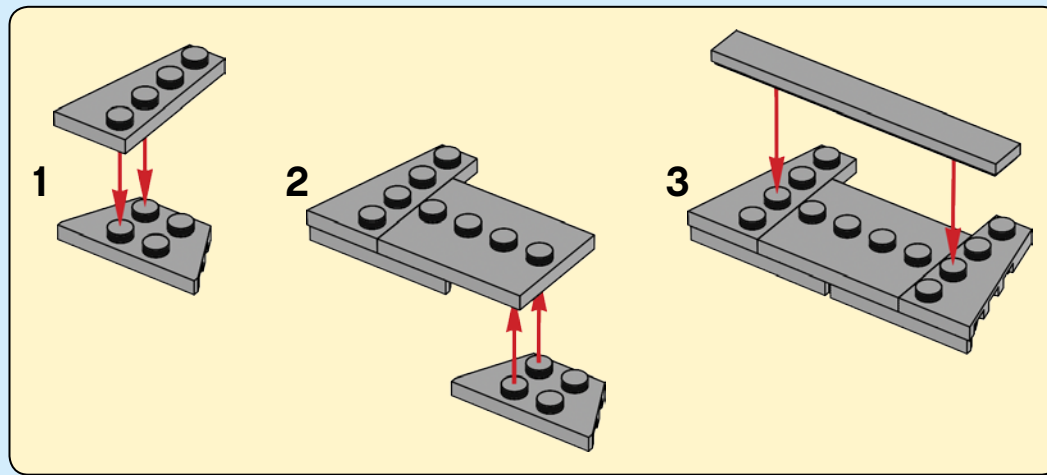

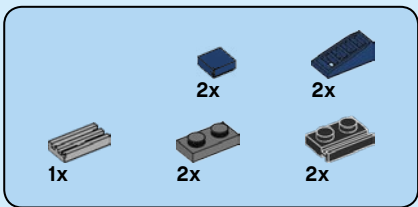

232

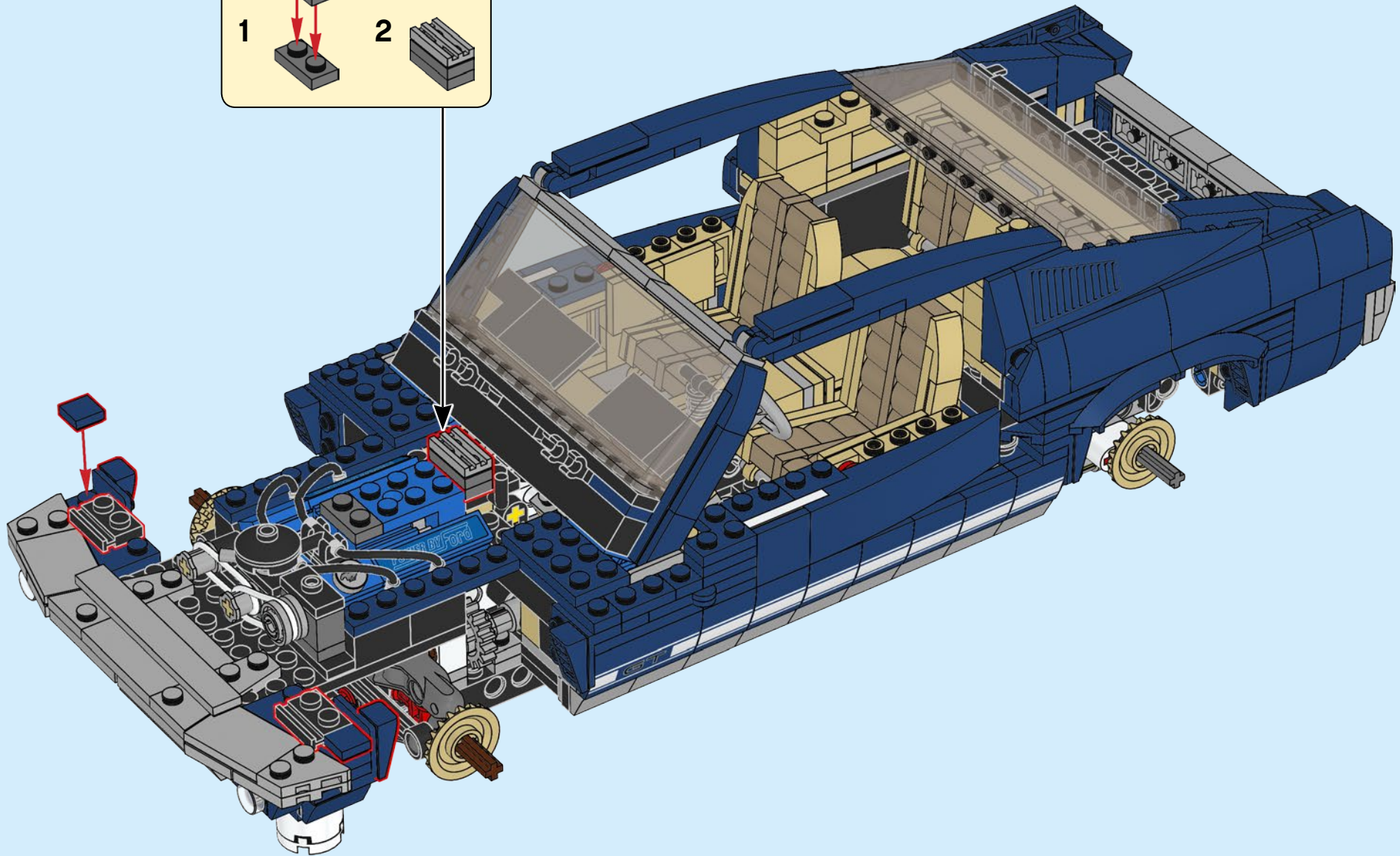
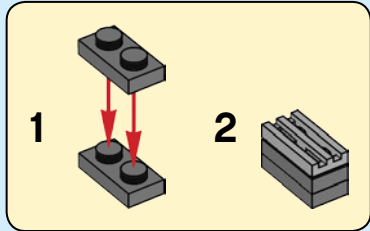

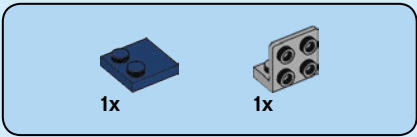

233

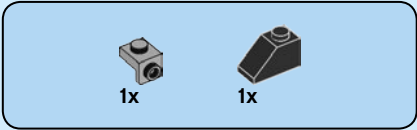
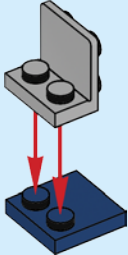

234

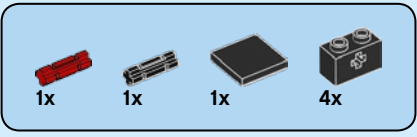
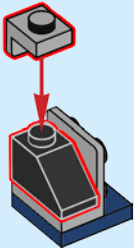

235

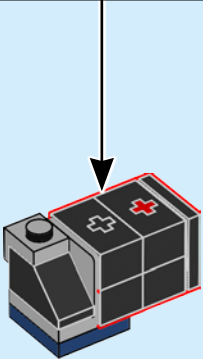
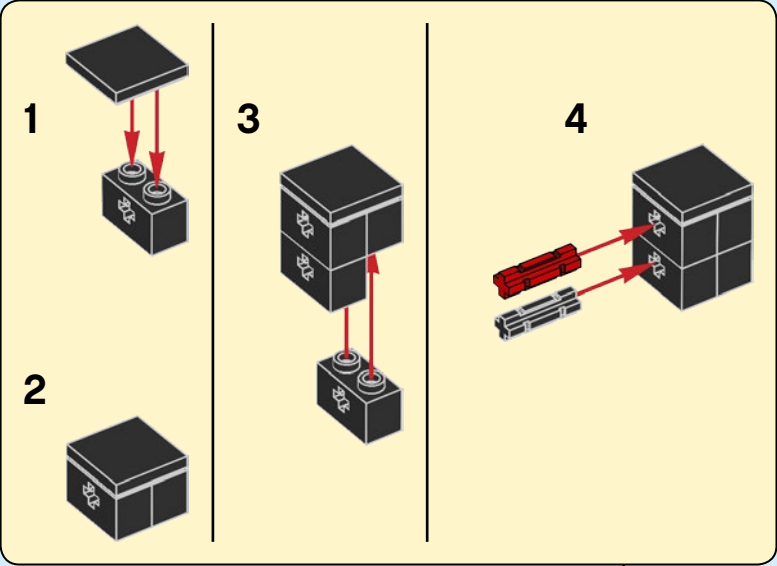

236

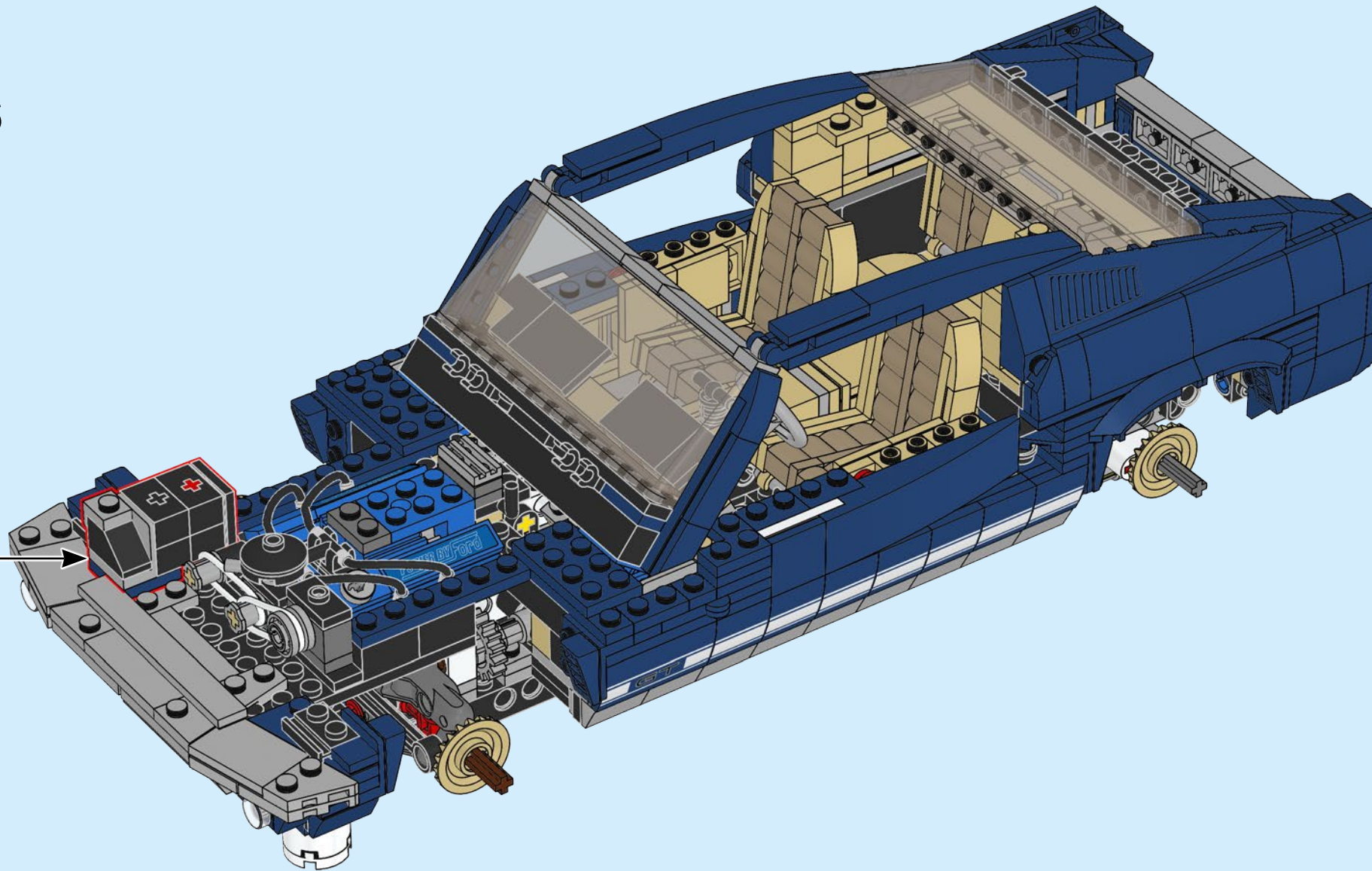

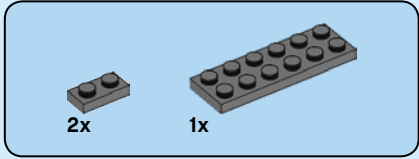
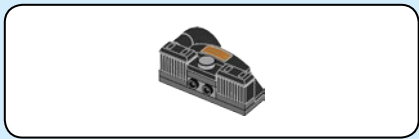

237

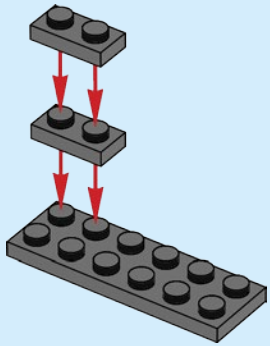

238

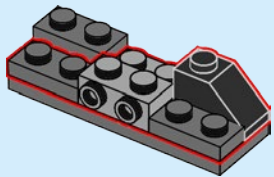

239

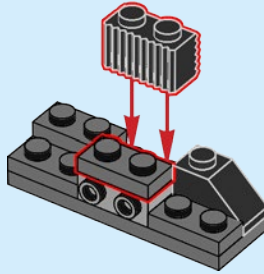

240

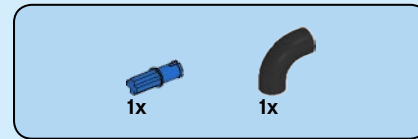
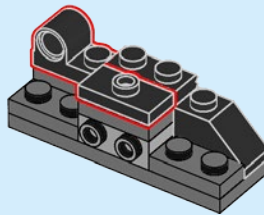

241

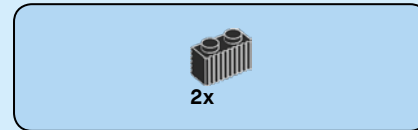
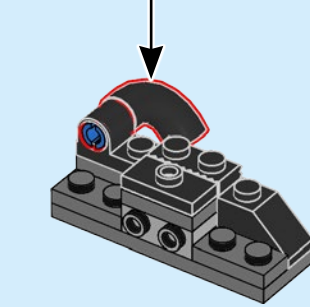
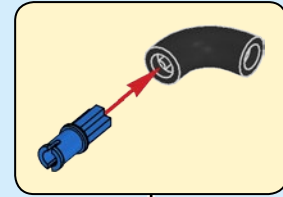

242

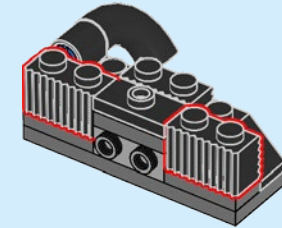

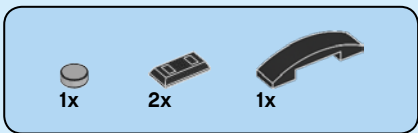

243

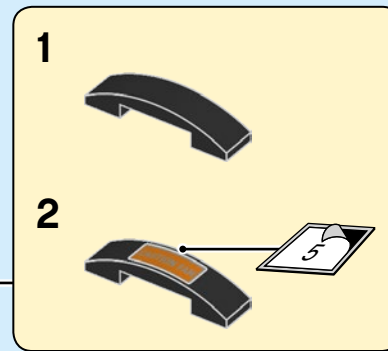
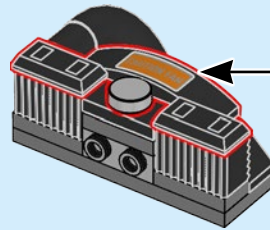

244

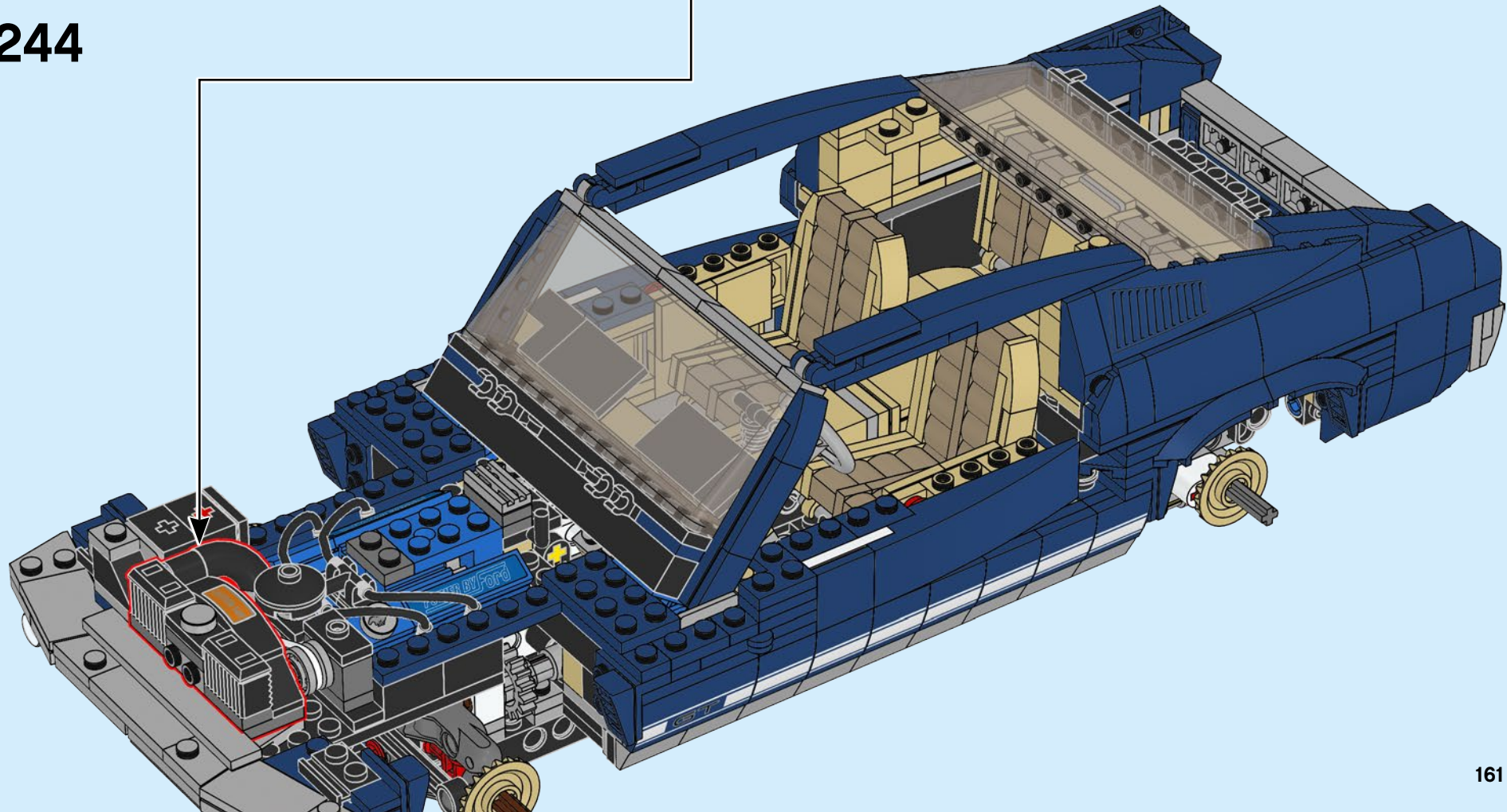

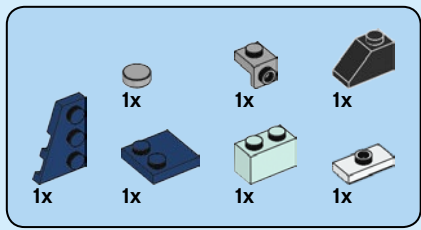

245

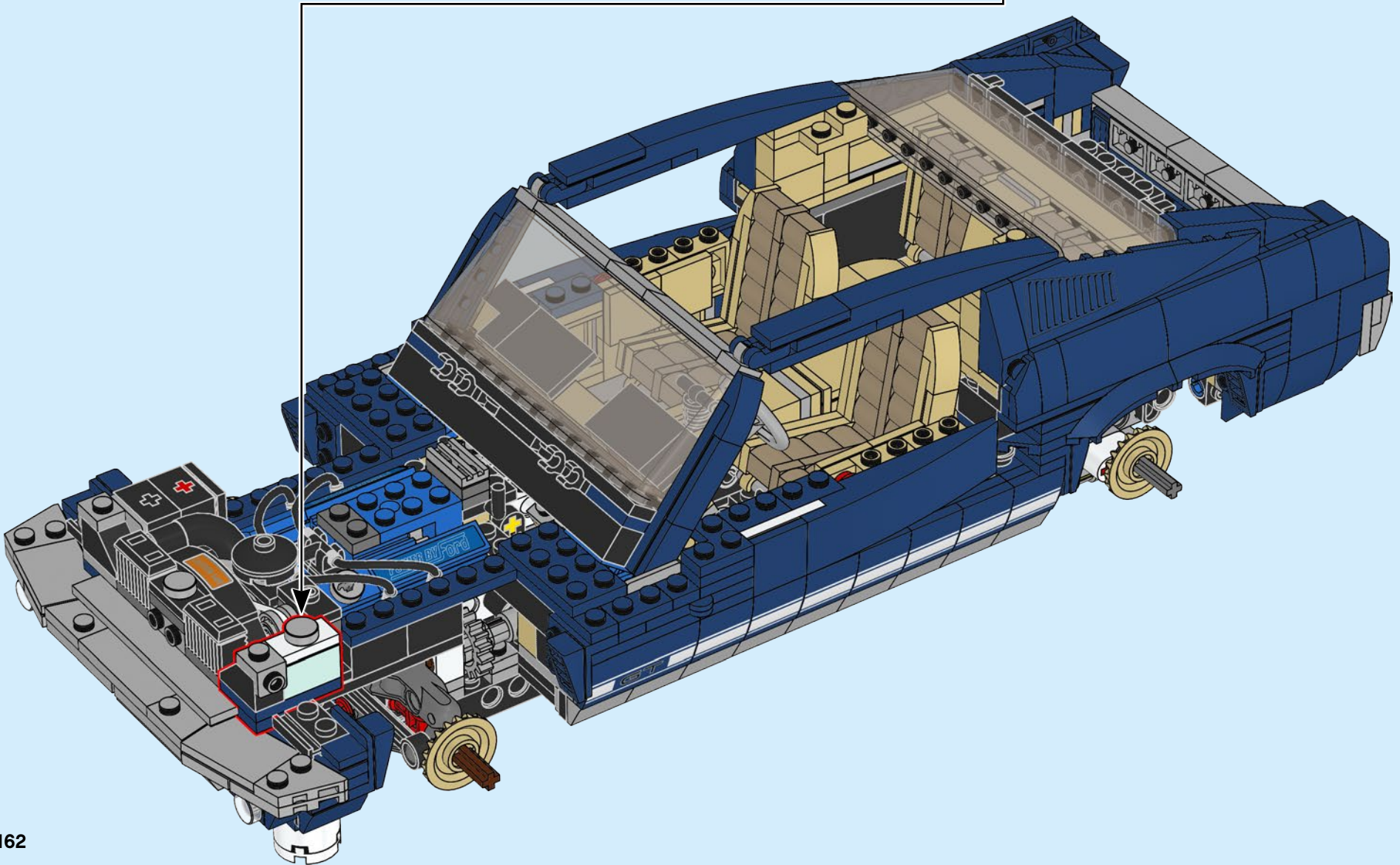
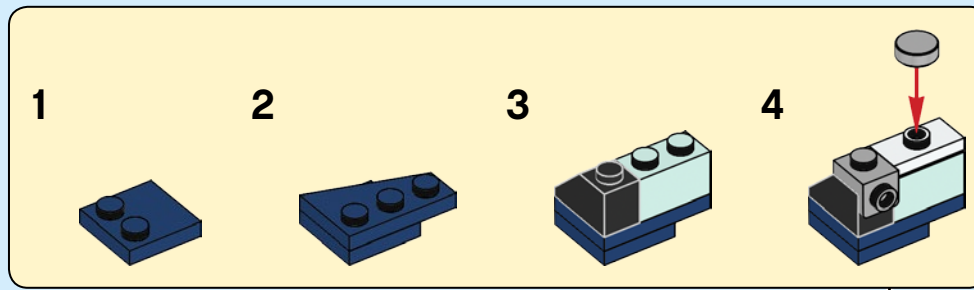

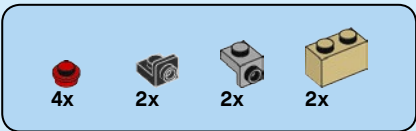

246

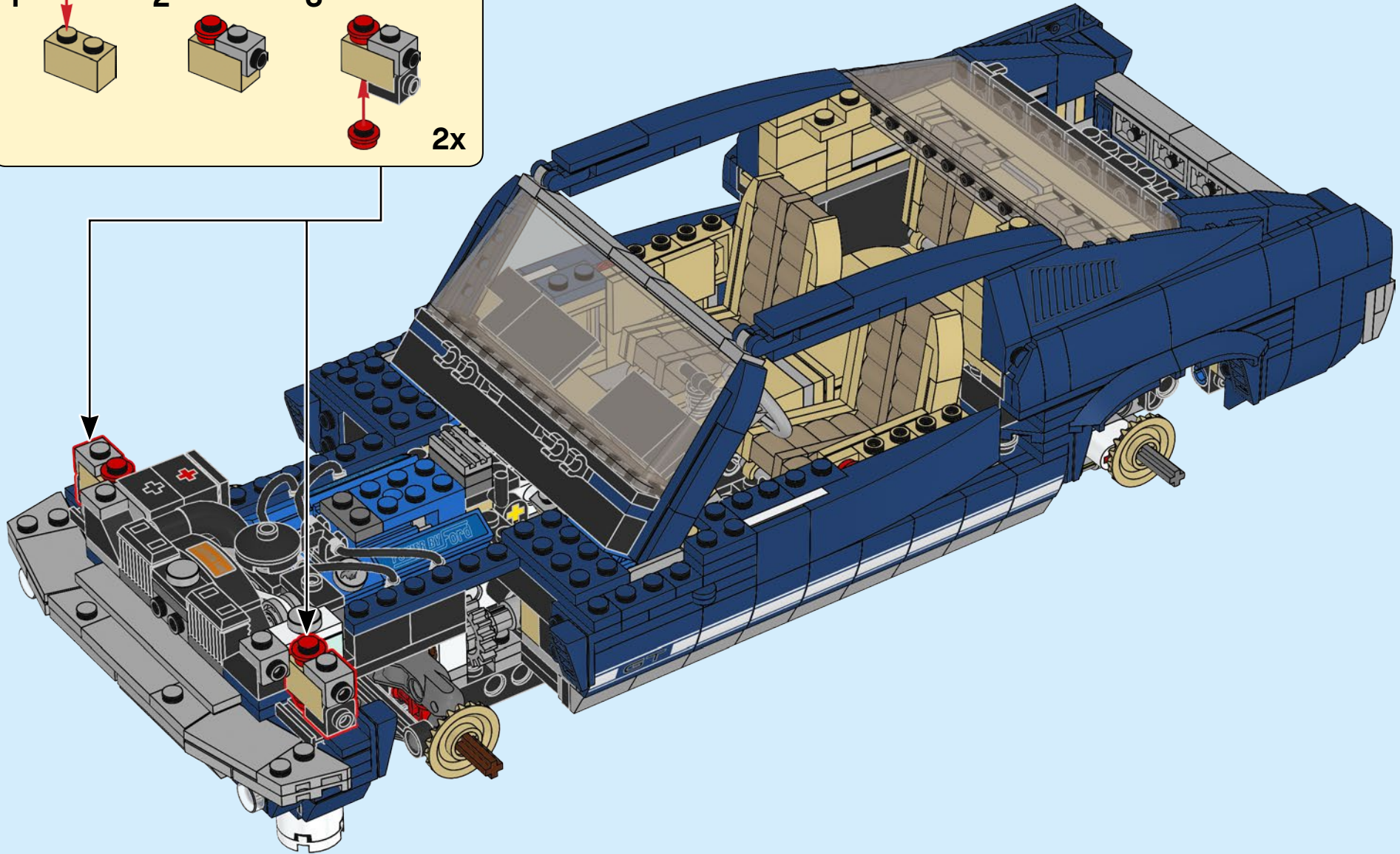
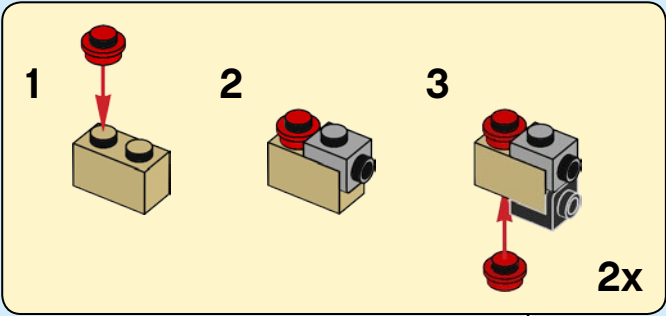

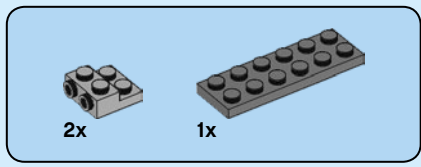

247

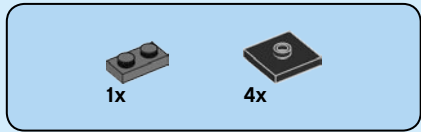
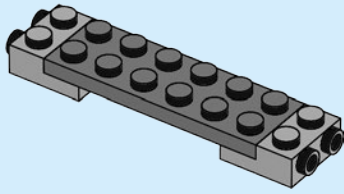

248

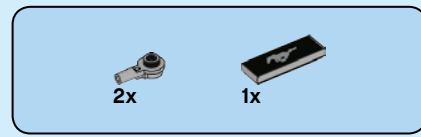
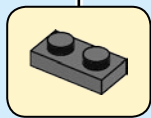
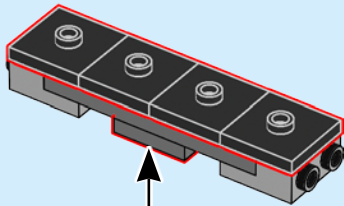

249

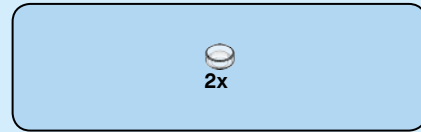
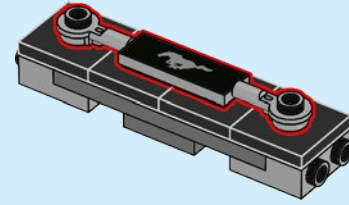

250

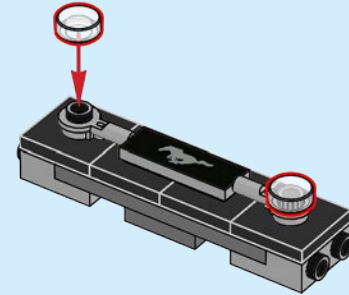

251

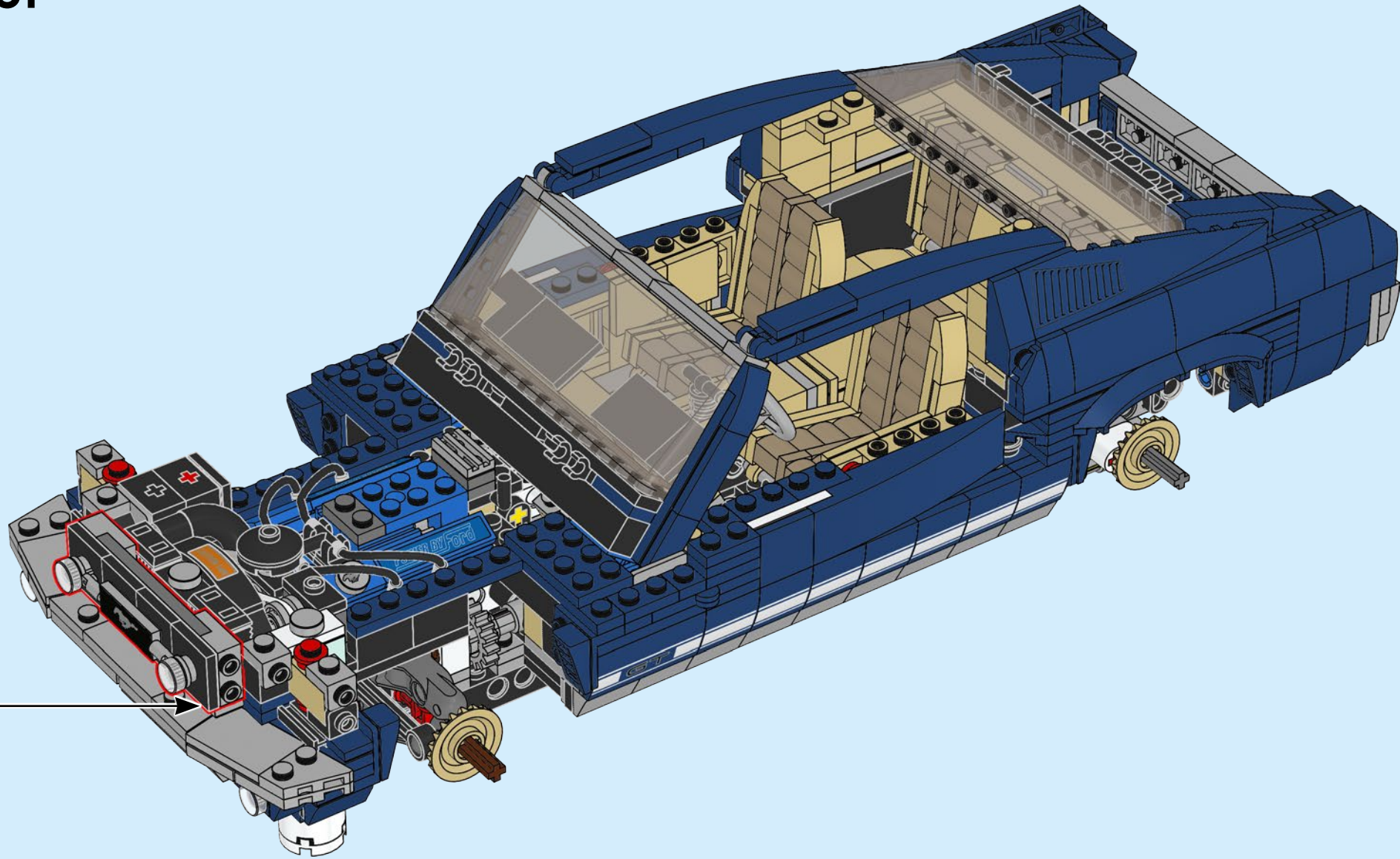

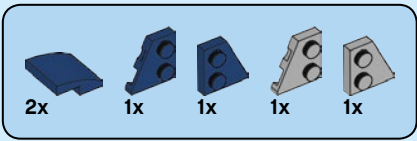

252

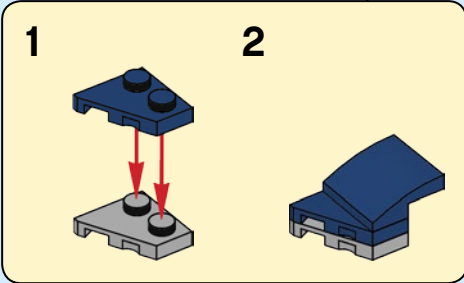
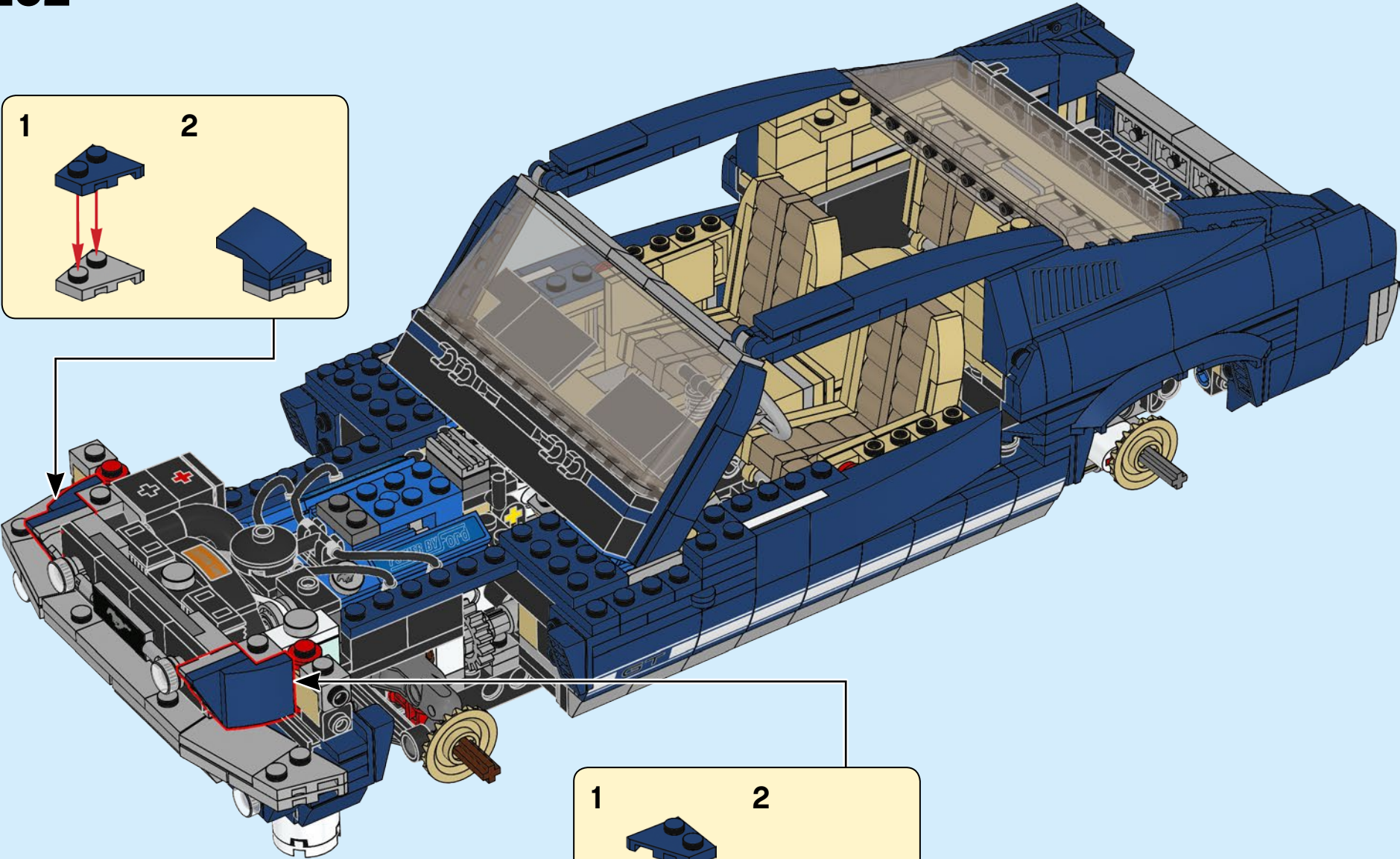
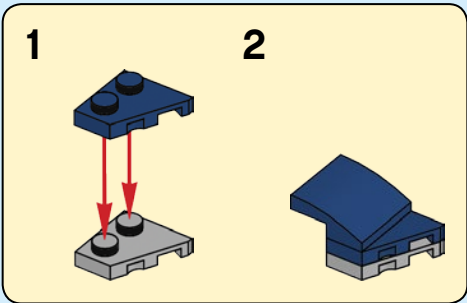

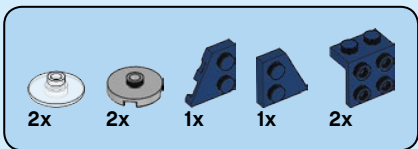

253

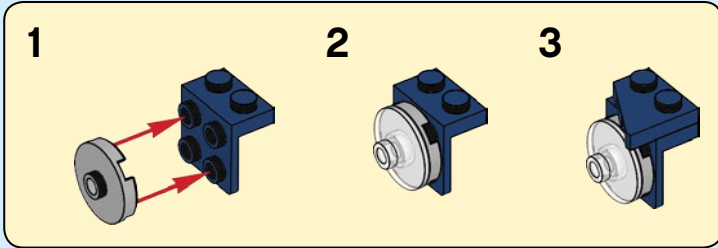

2

3

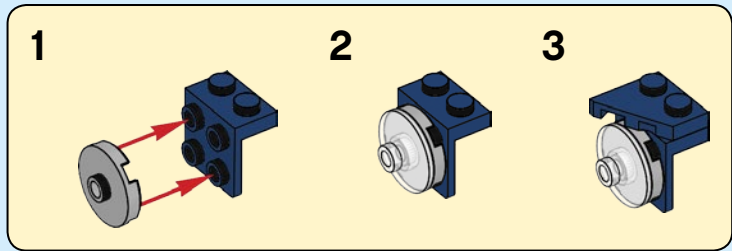
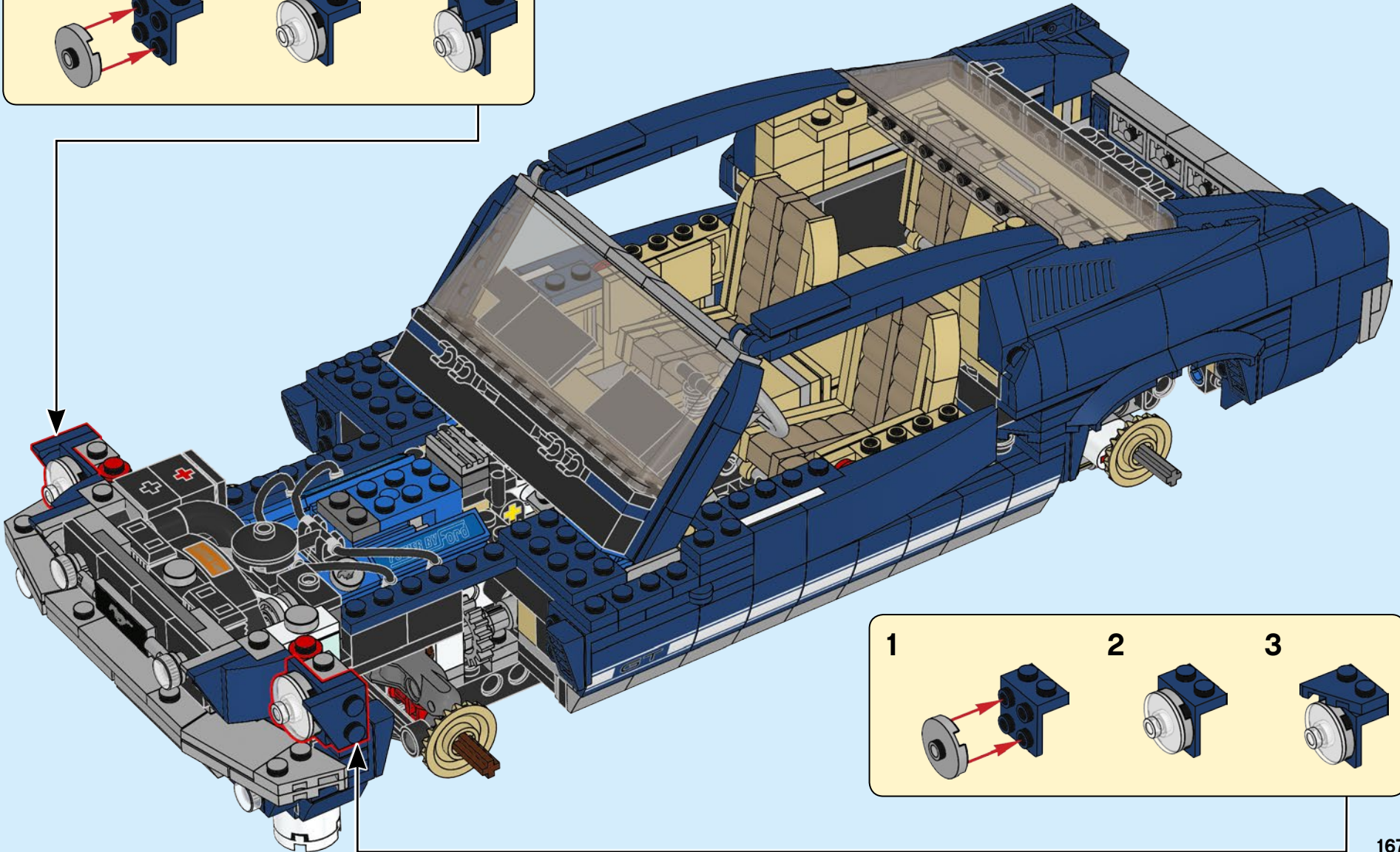

2

3

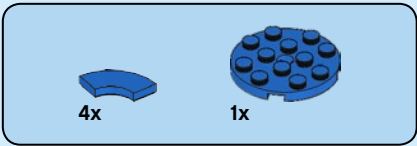

254

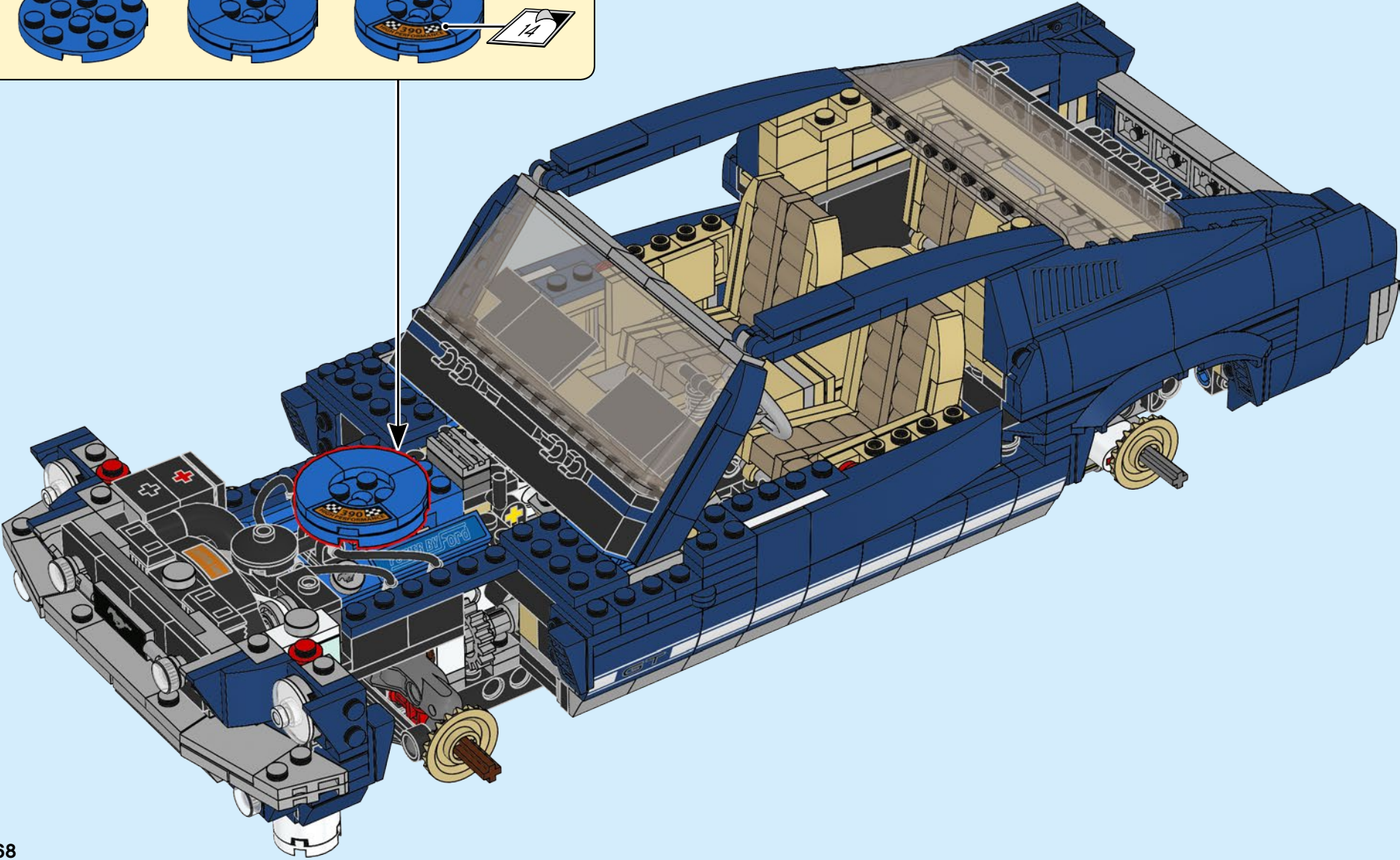
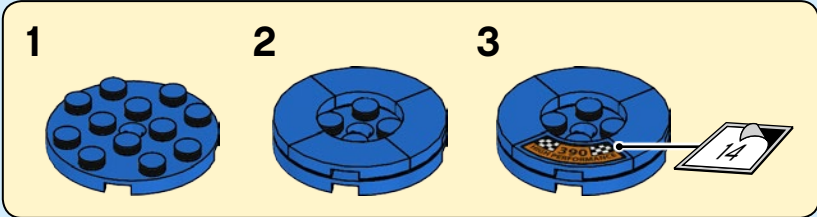

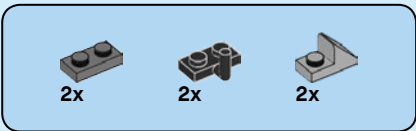

255

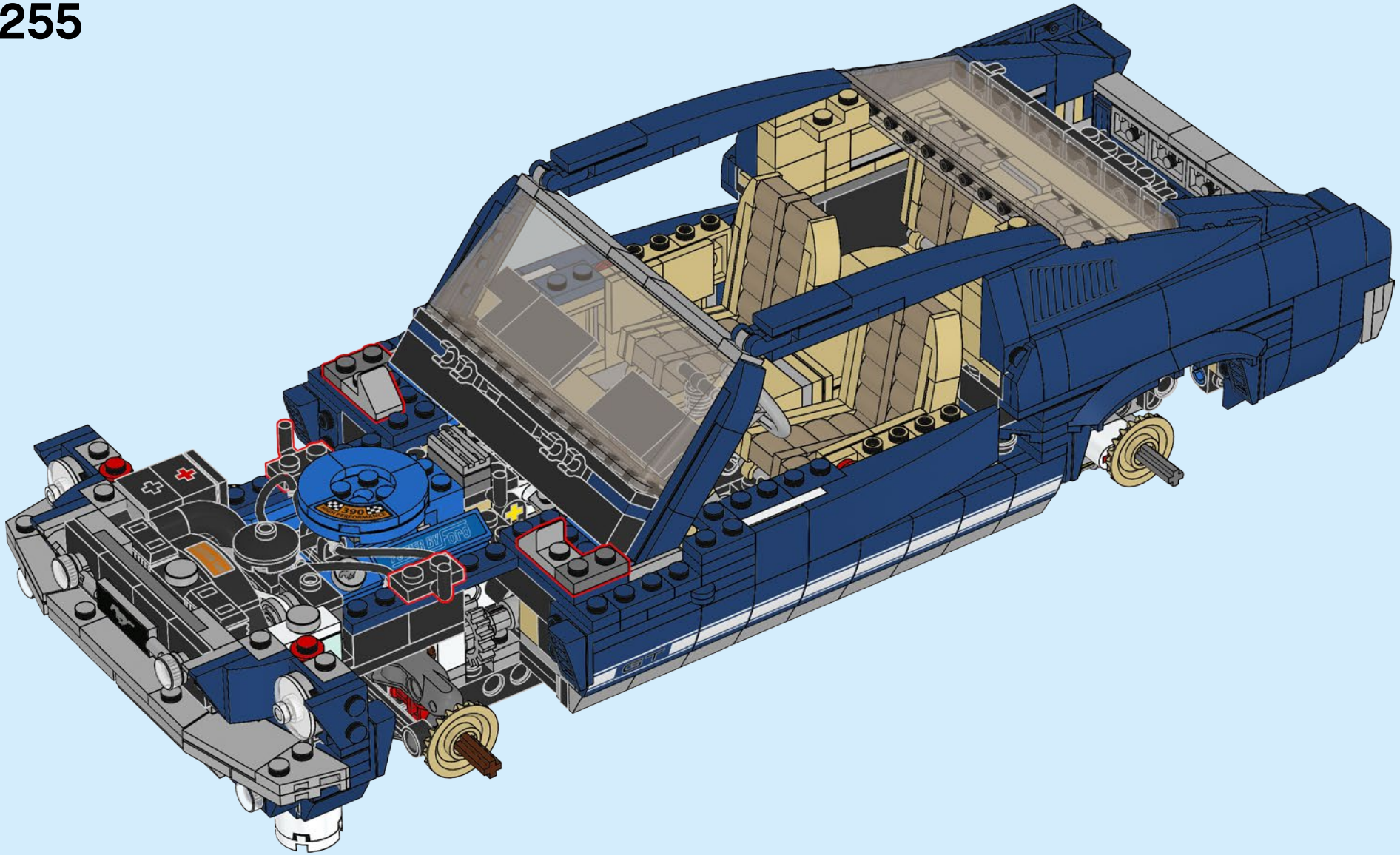

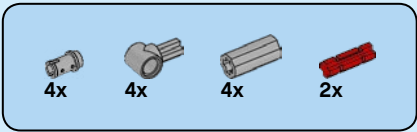

256

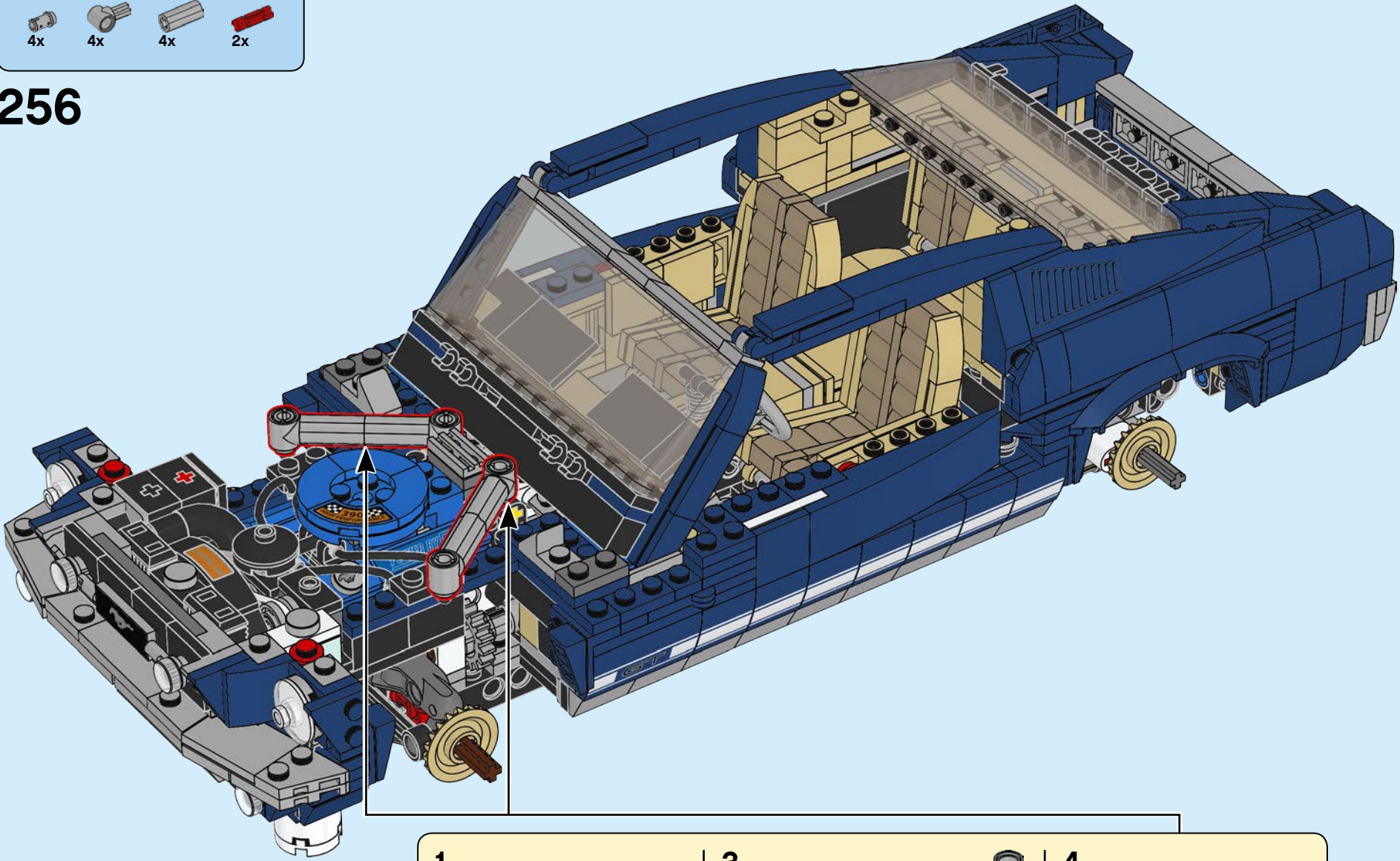

<p>1</p> <p>2</p>	<p>3</p>	<p>4</p> <p>2x</p>
-------------------	----------	--------------------

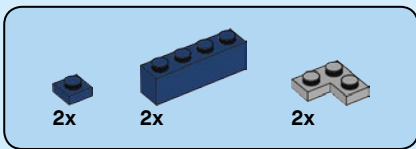

257

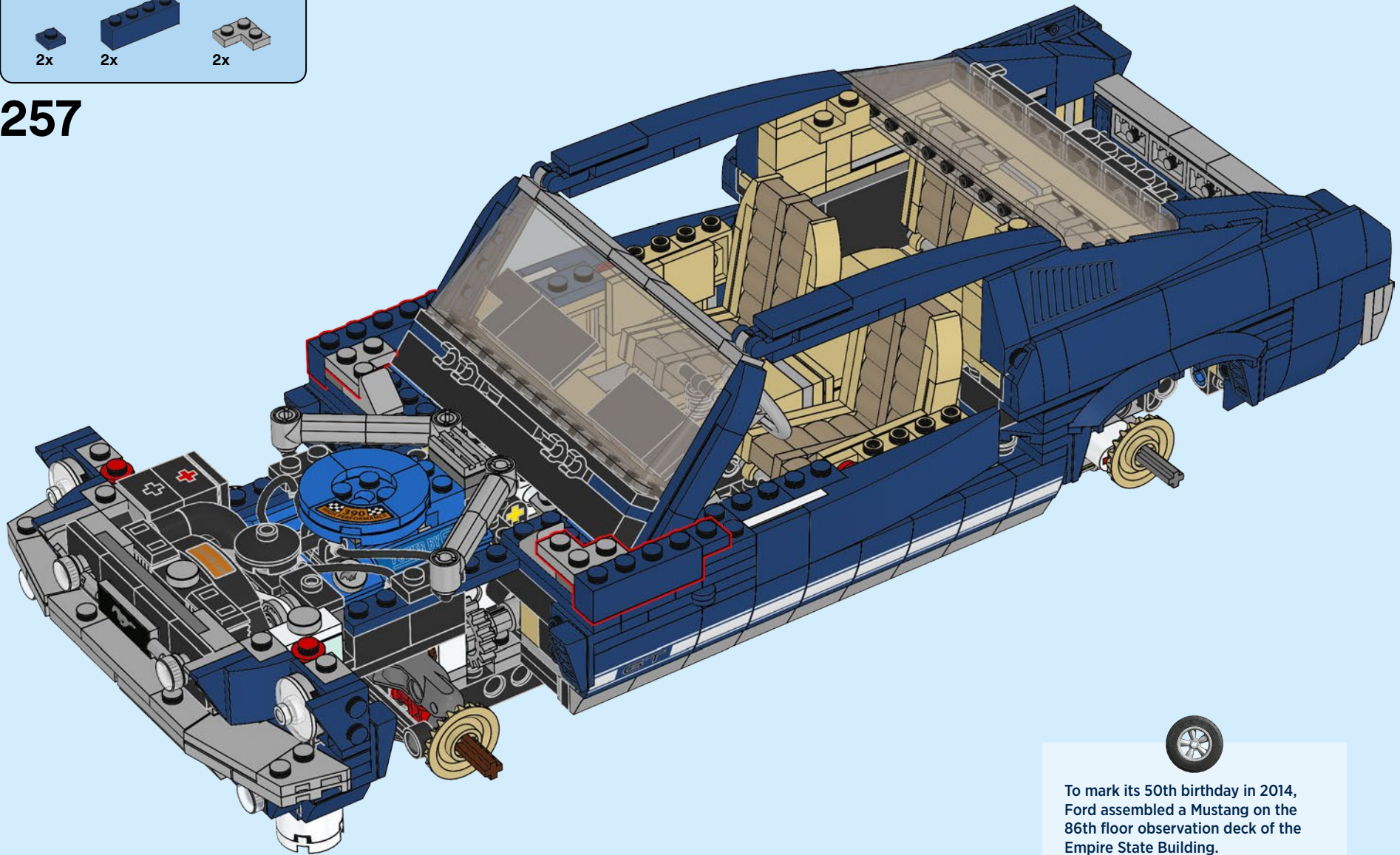

To mark its 50th birthday in 2014, Ford assembled a Mustang on the 86th floor observation deck of the Empire State Building.

À l'occasion de son 50e anniversaire, en 2014, Ford a assemblé une Mustang sur la terrasse d'observation du 86e étage de l'Empire State Building.

Para celebrar su 50 aniversario en 2014, Ford ensambló un Mustang en la plataforma de observación del piso 86 del Empire State Building.

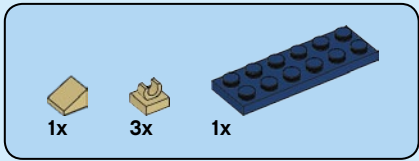
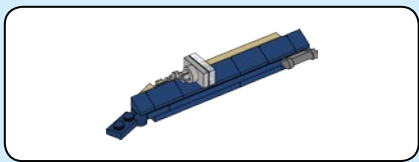

258

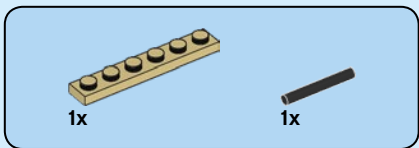
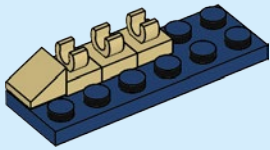

259

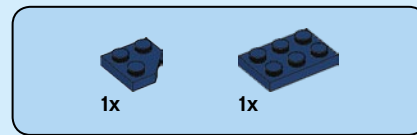
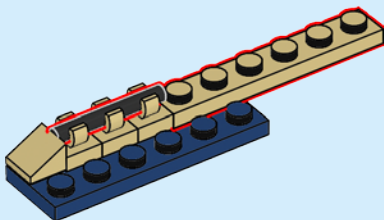

260

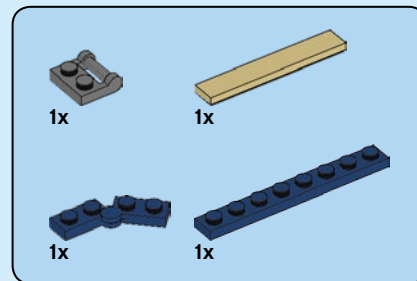
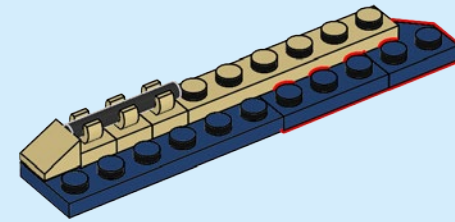

261

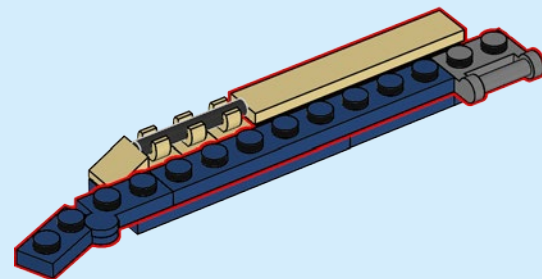

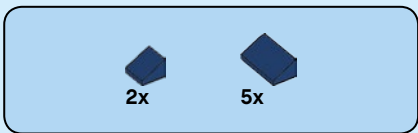

262

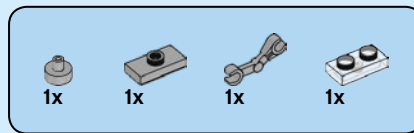
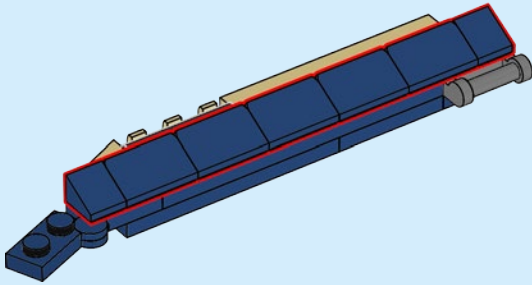

263

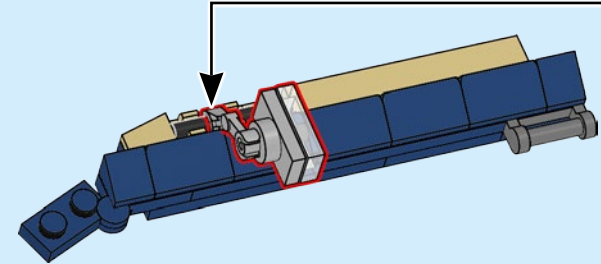
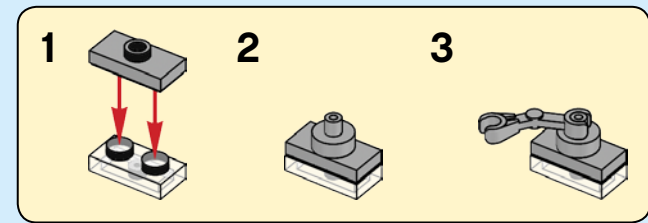

264

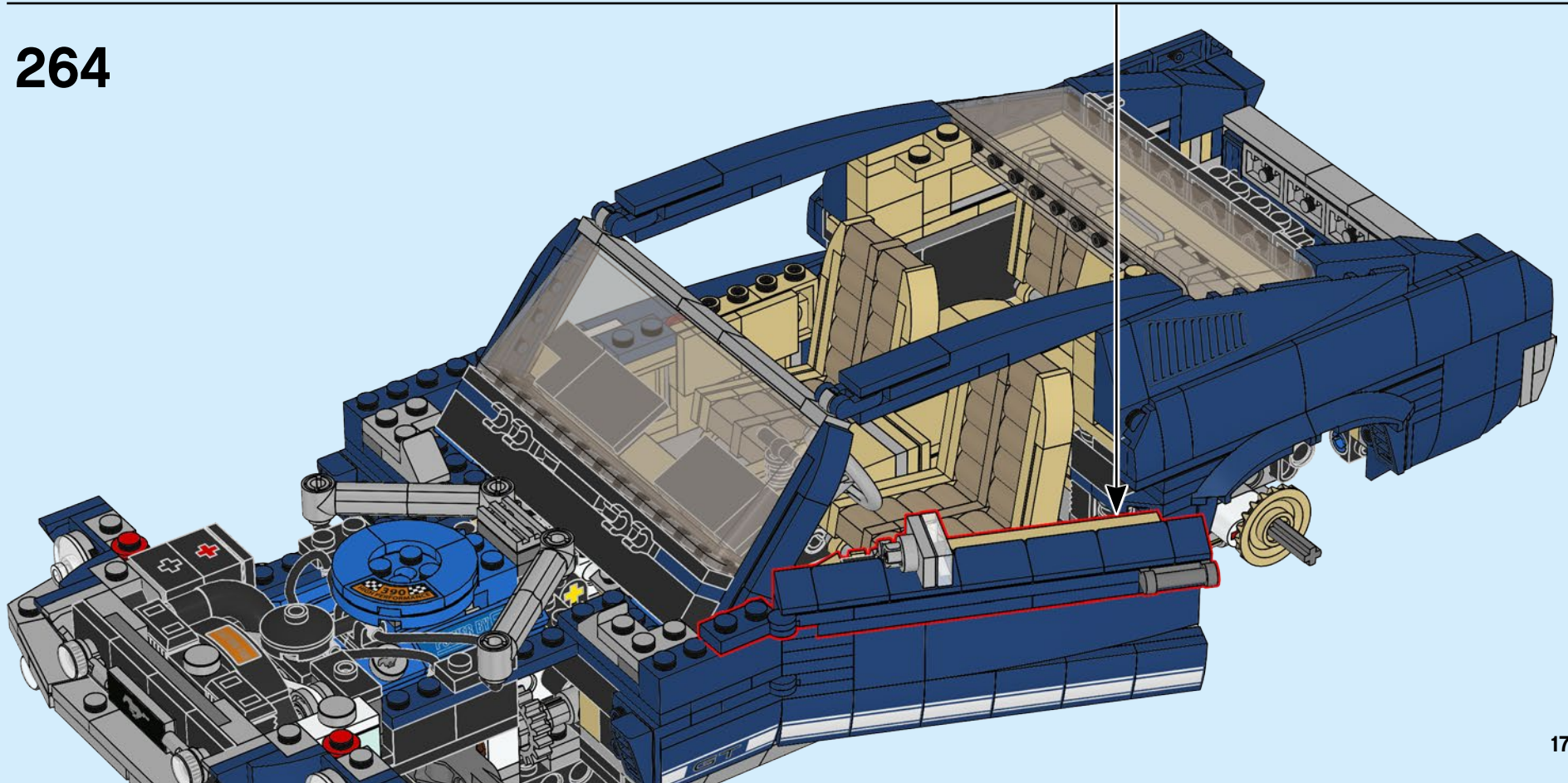

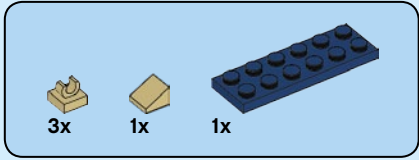
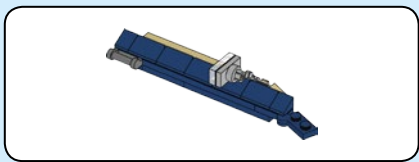

265

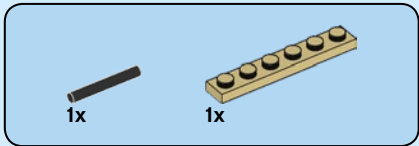
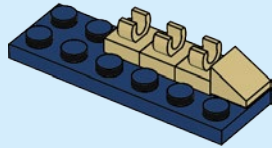

266

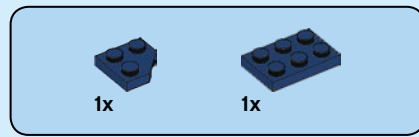
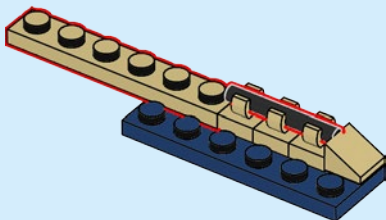

267

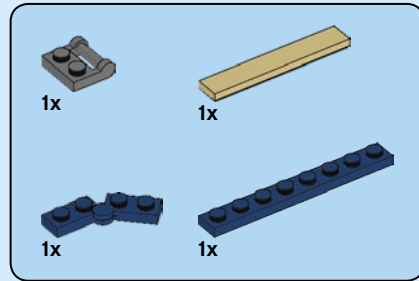
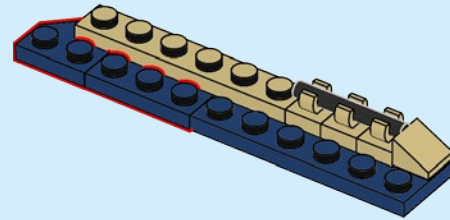

268

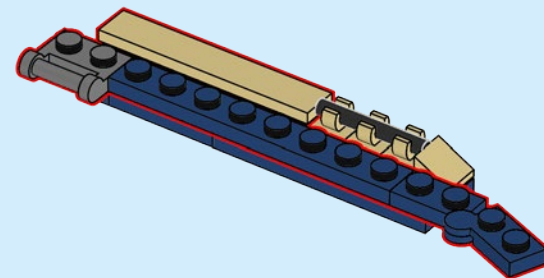

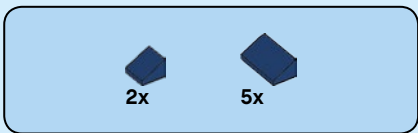

269

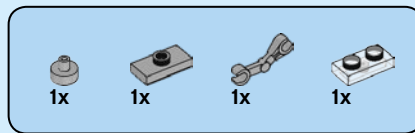
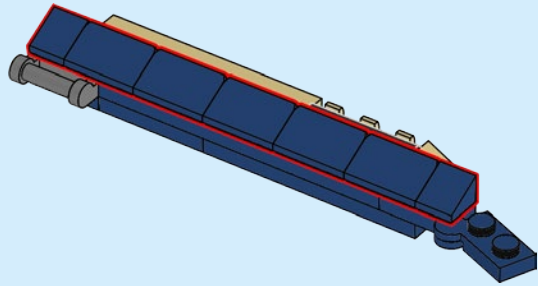

270

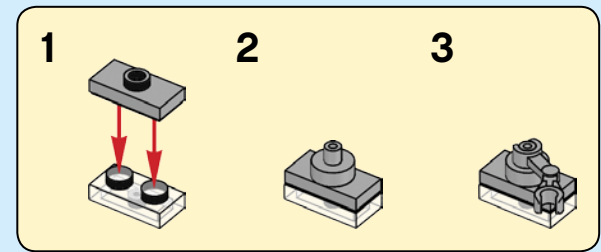
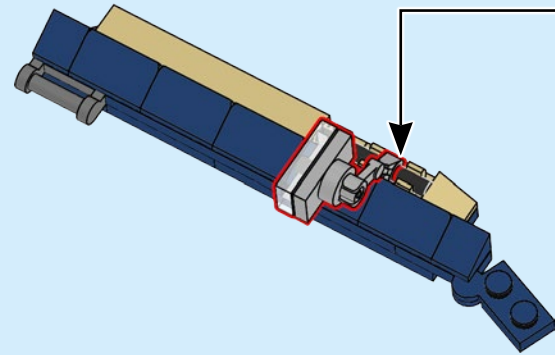

271

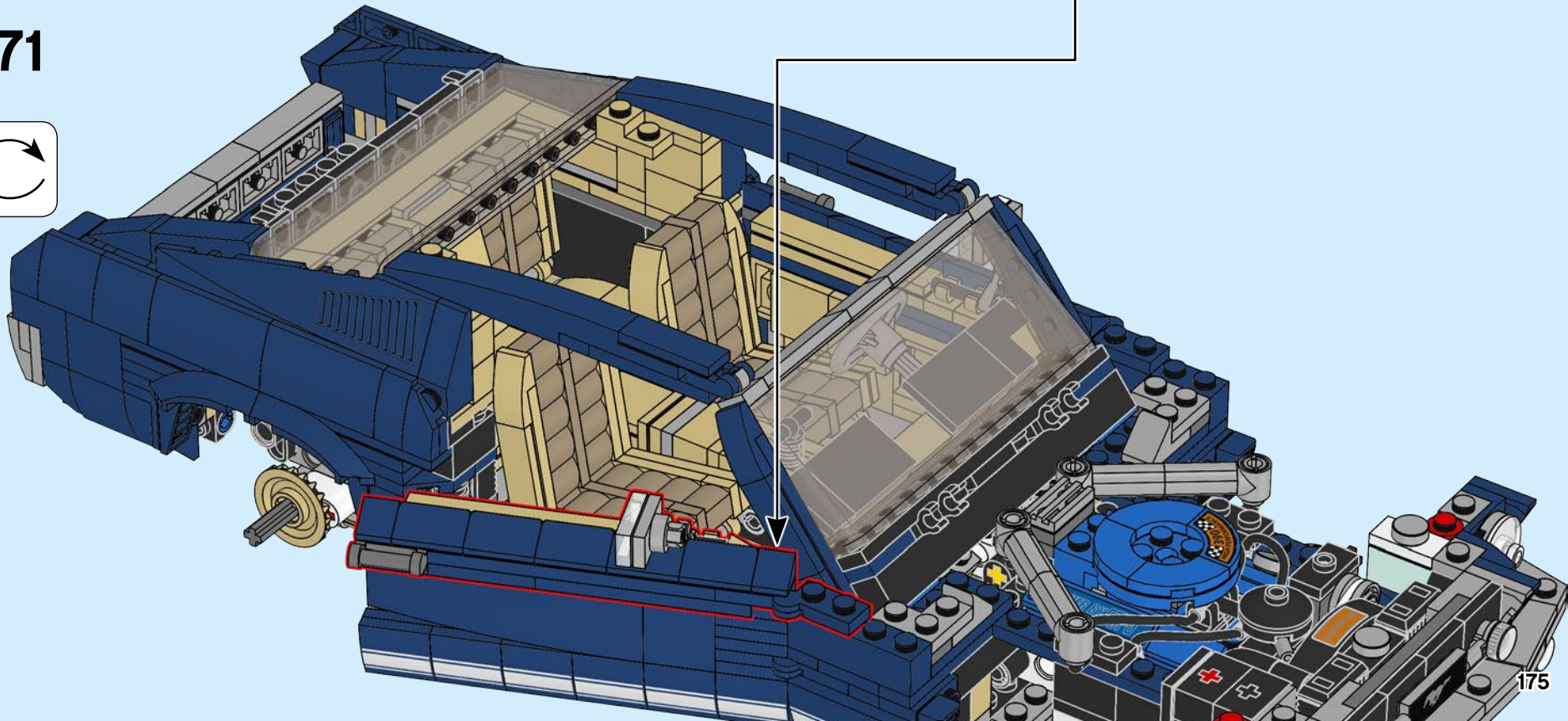
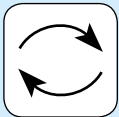

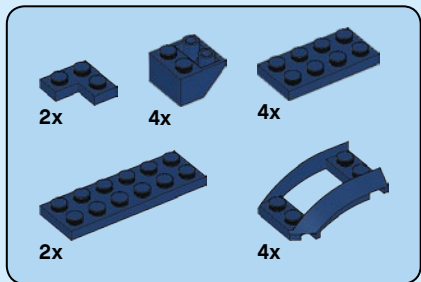
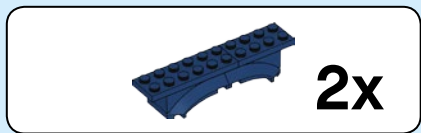

272

1

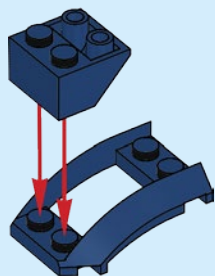

2

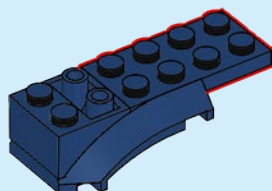

3

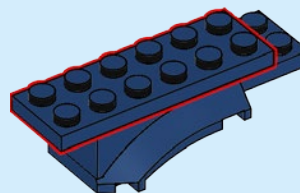

4

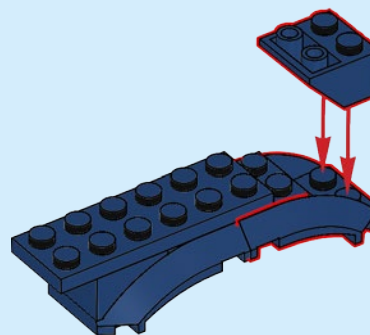

5

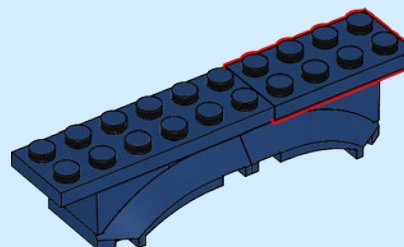

2x

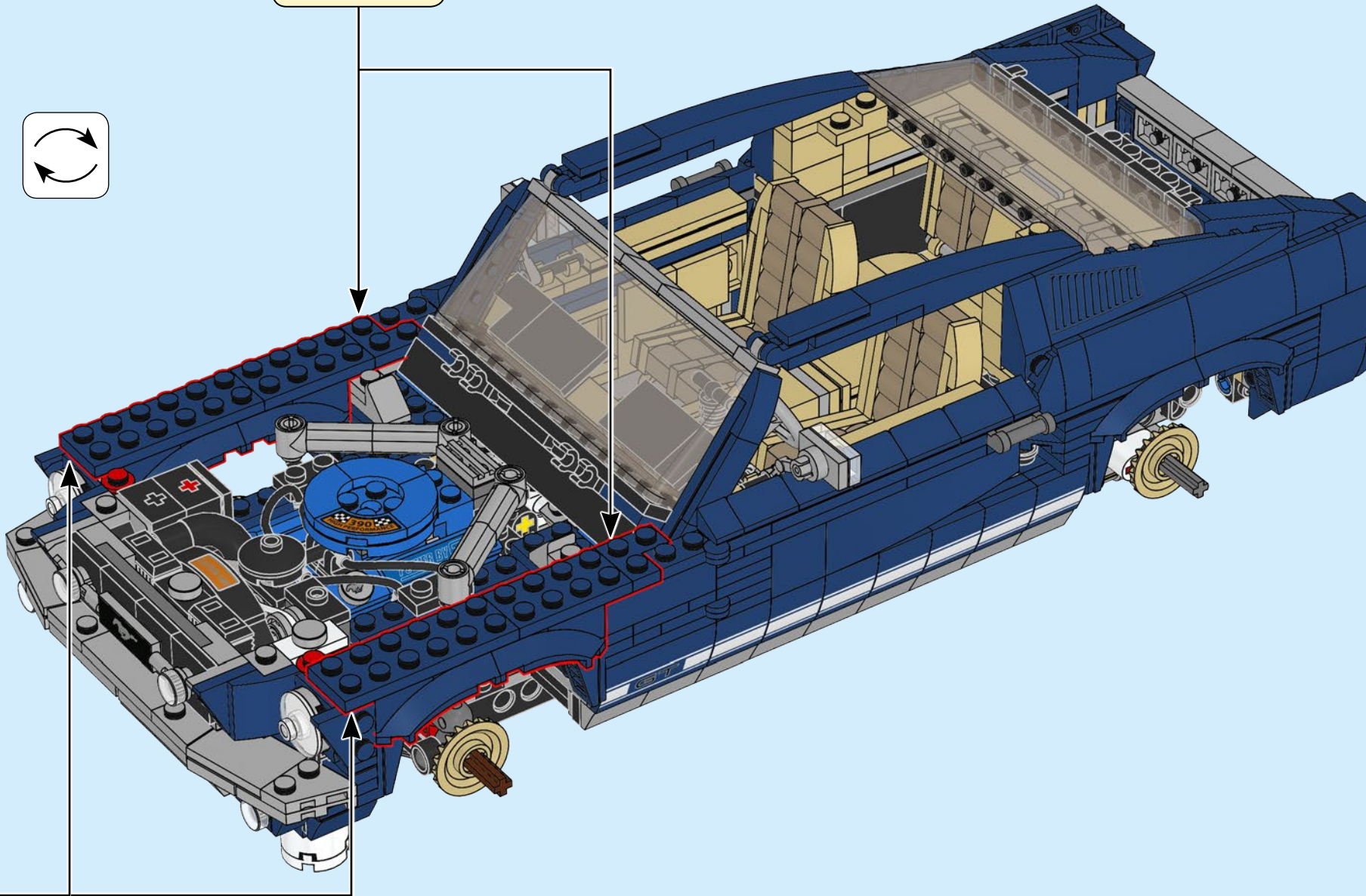
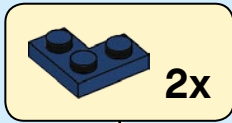
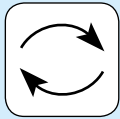

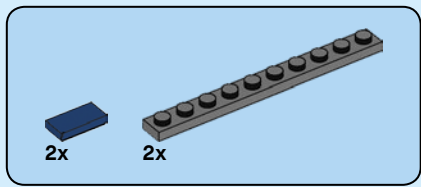

273

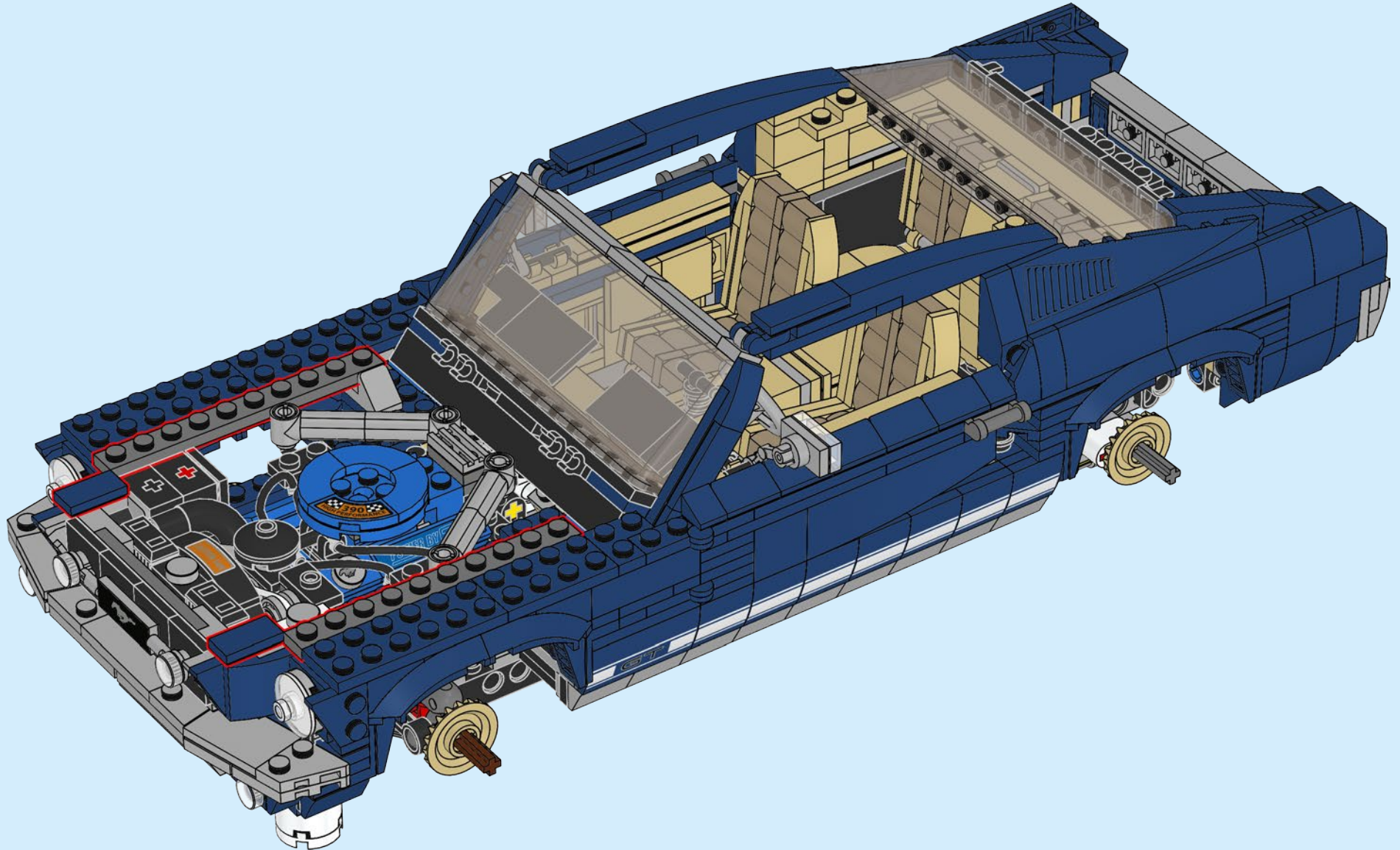

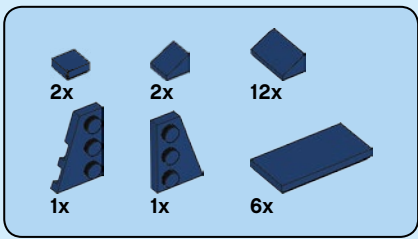

274

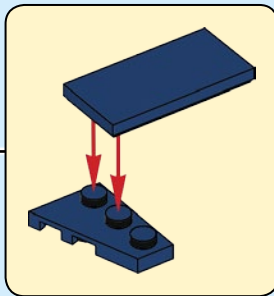
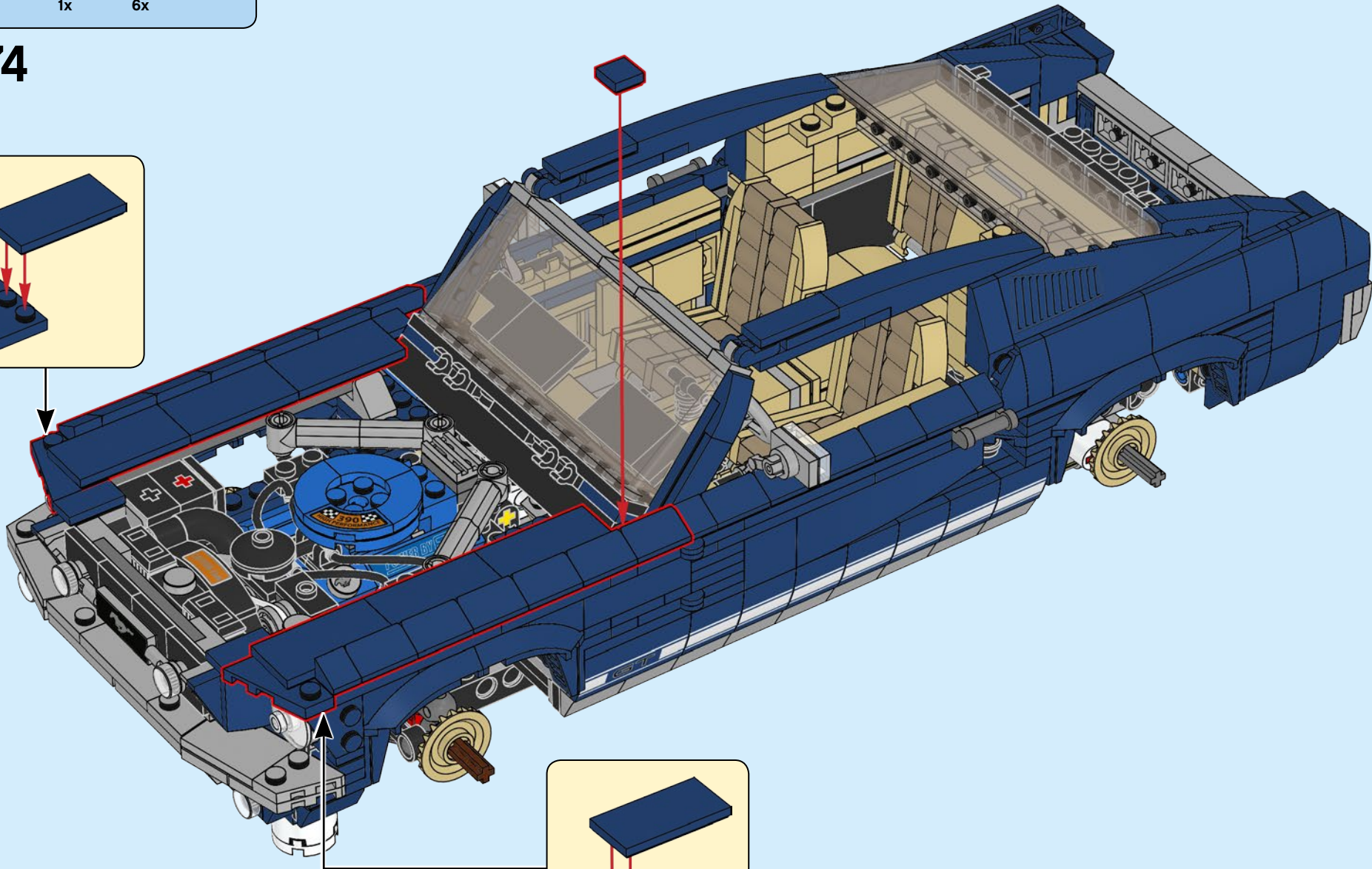
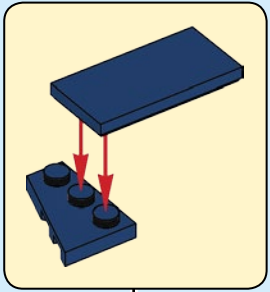

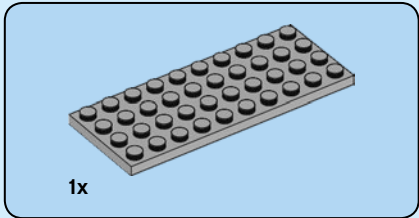
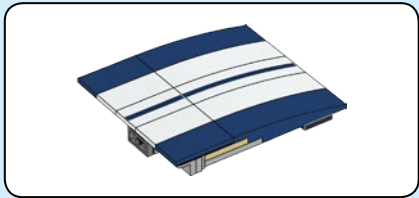
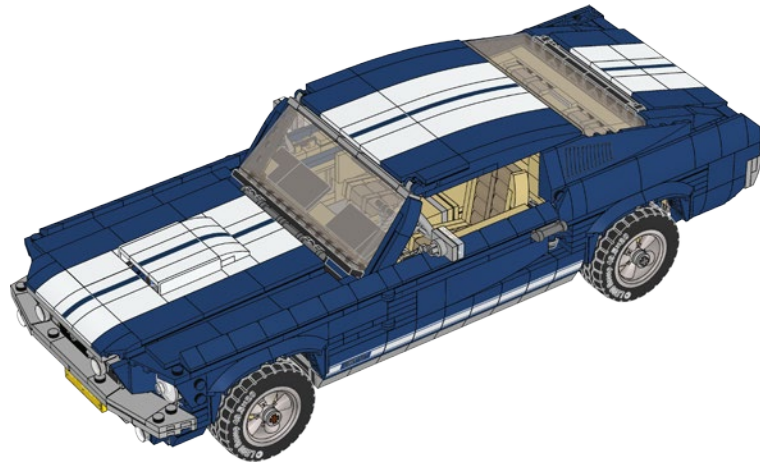
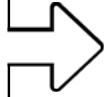
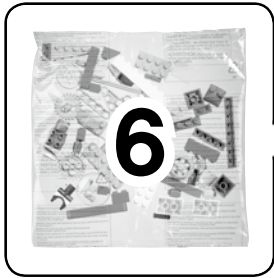

1x

275

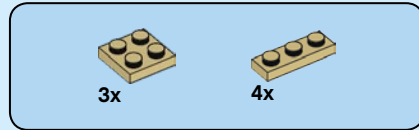
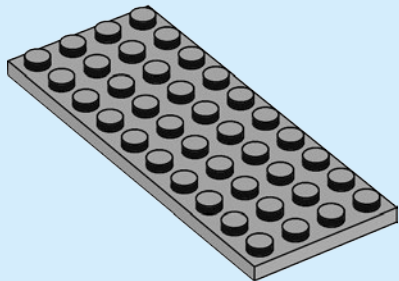

3x

4x

276

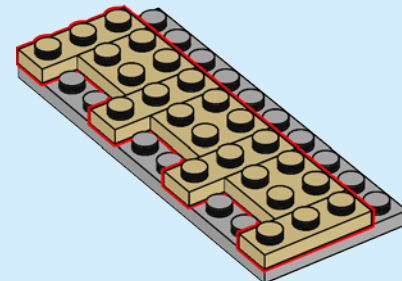

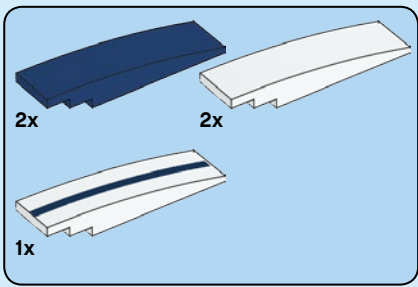

277

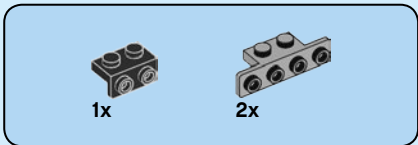
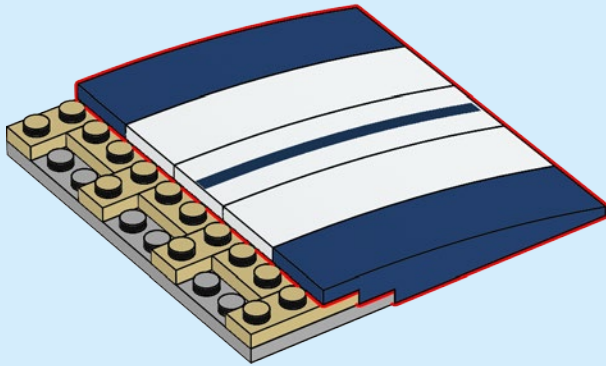

278

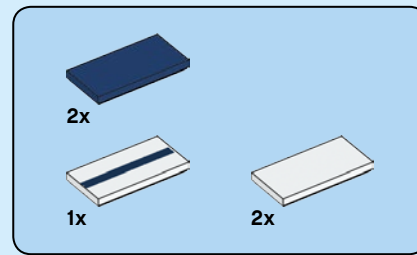
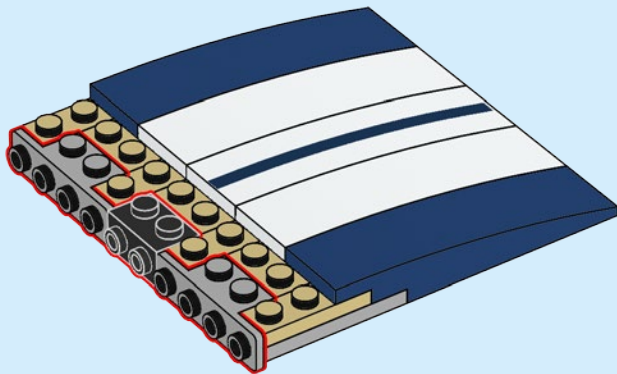

279

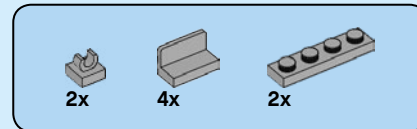
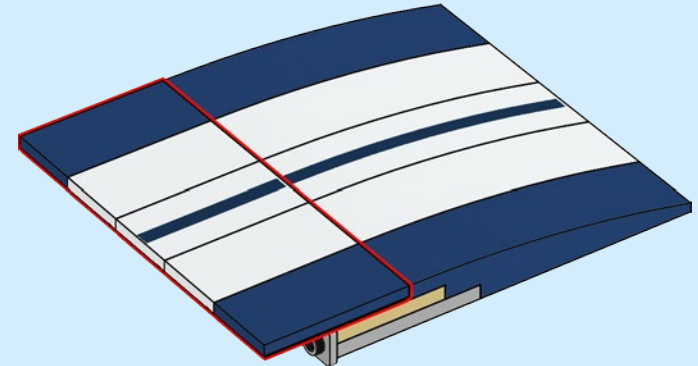

280

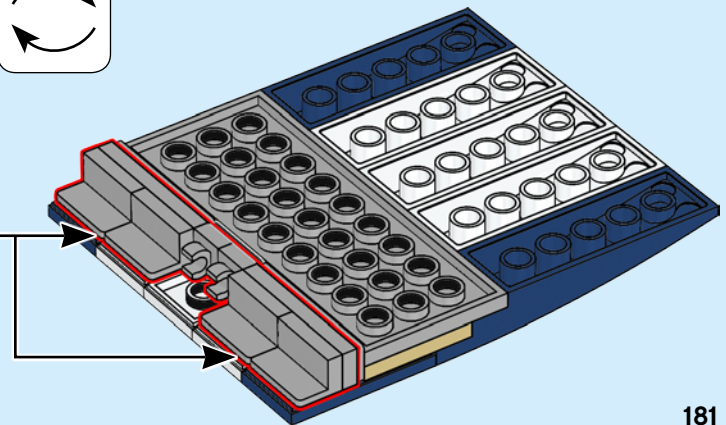
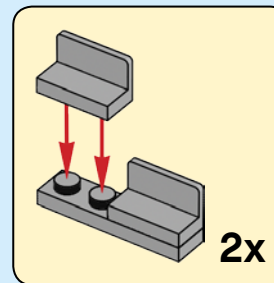
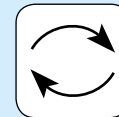

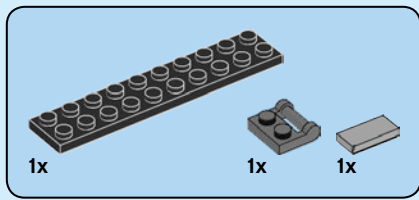

281

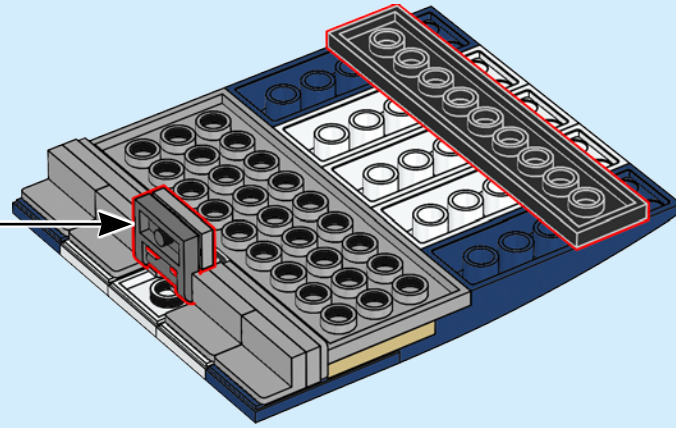
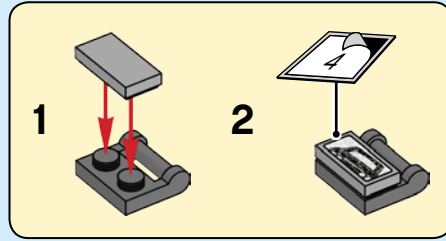

282

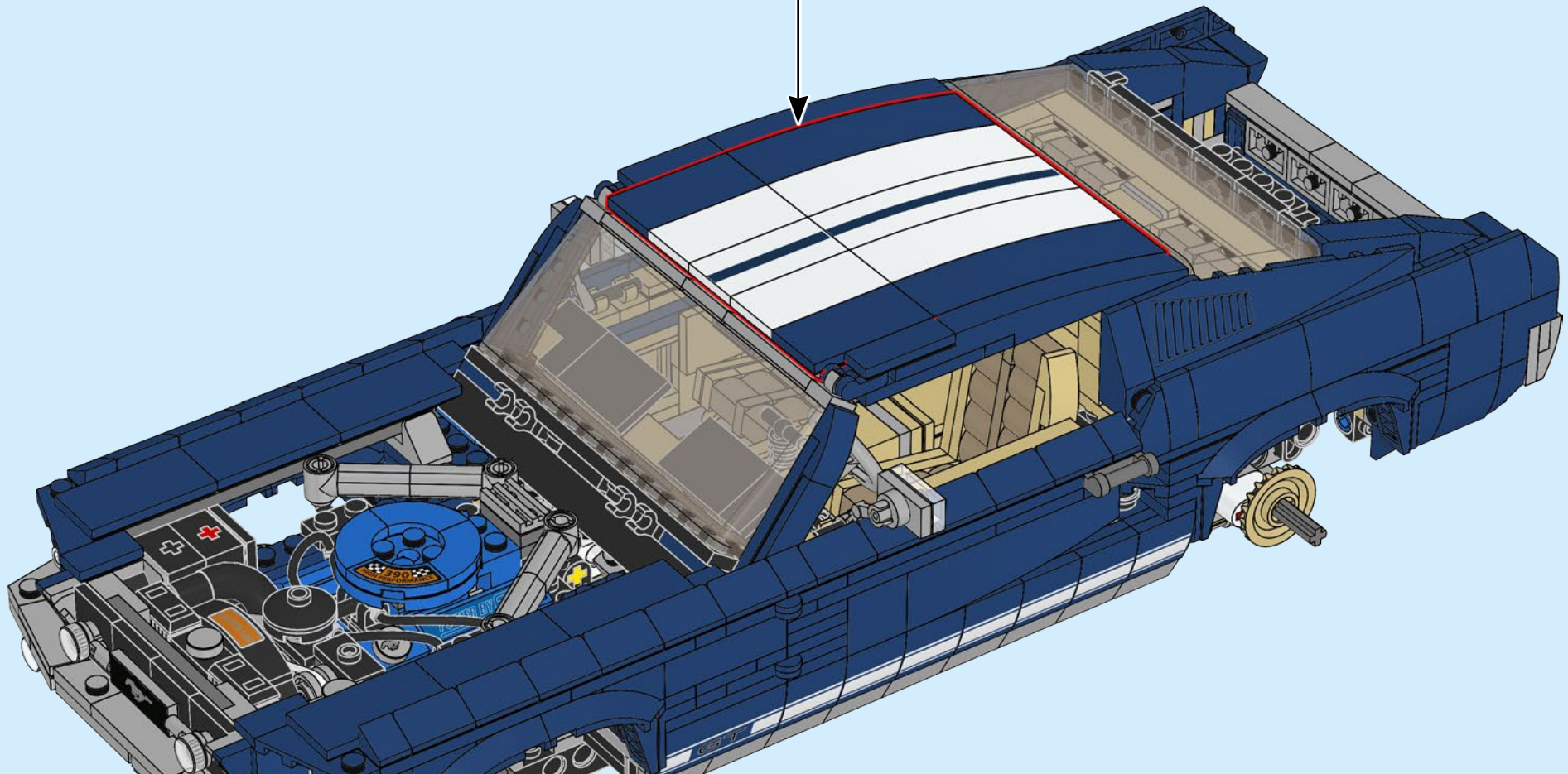

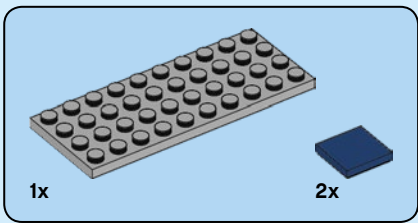

283

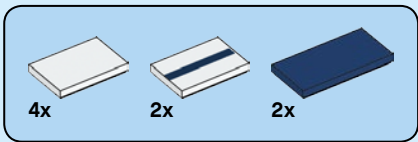
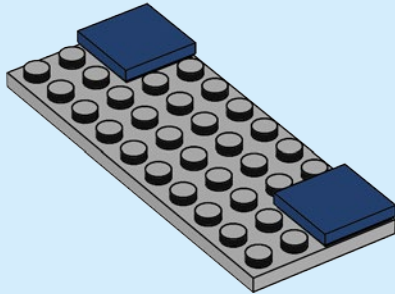

284

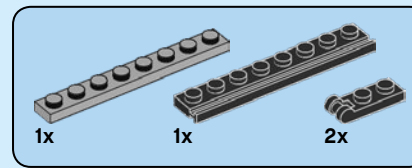
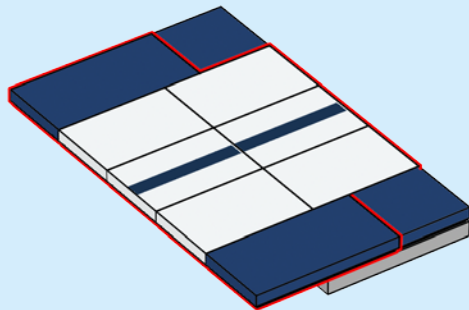

285

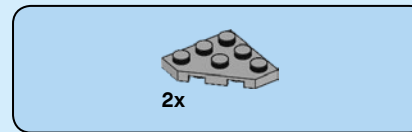
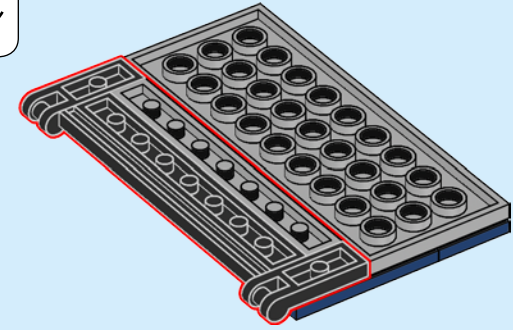
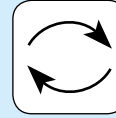

286

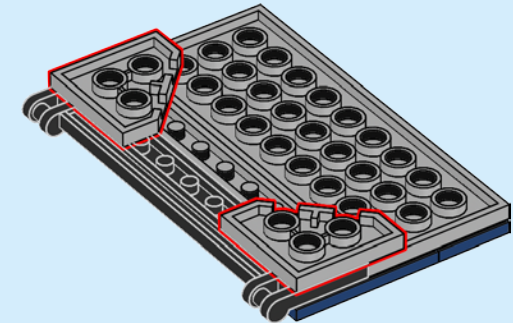

287

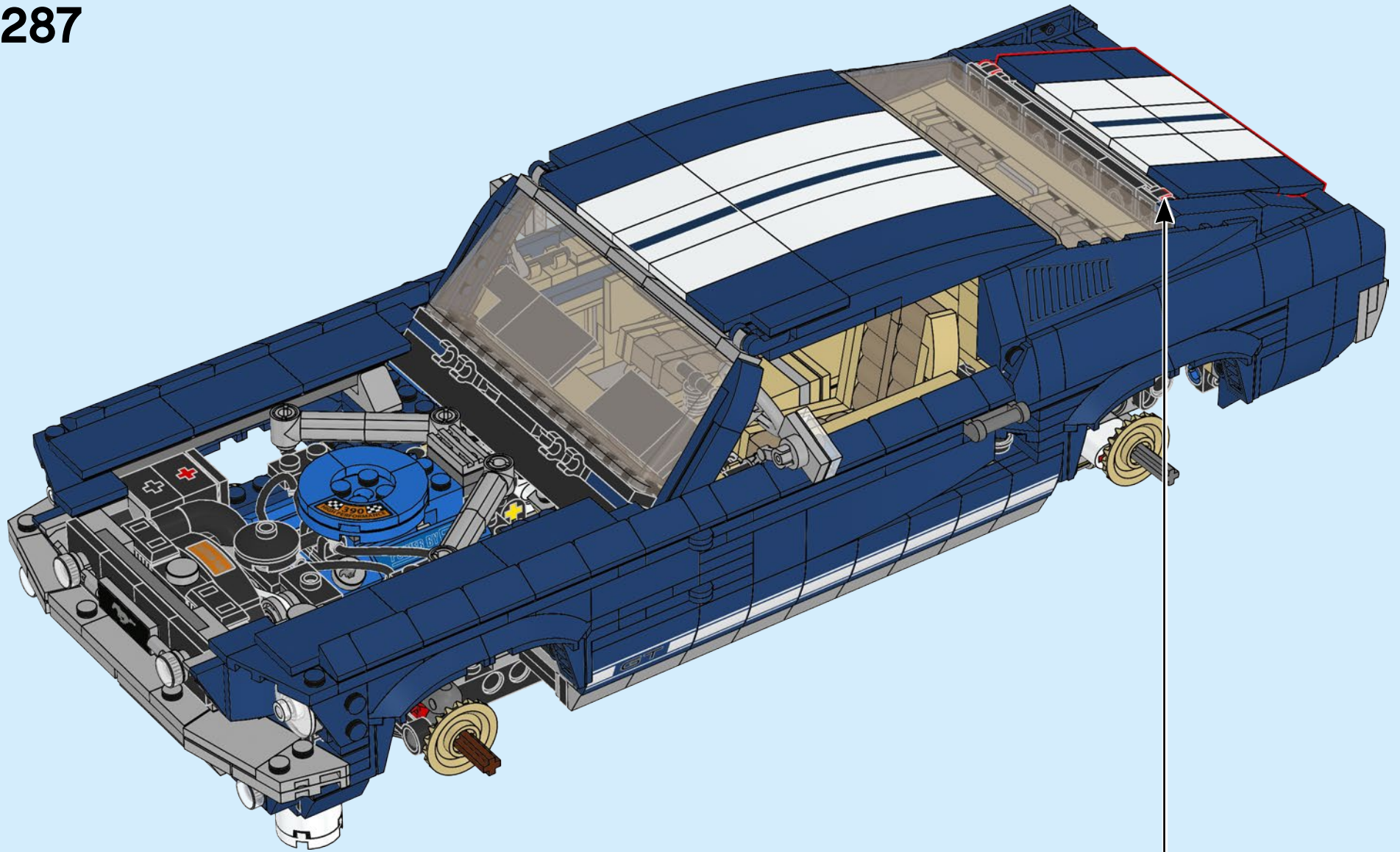

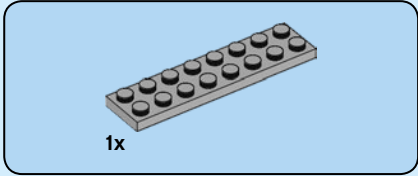
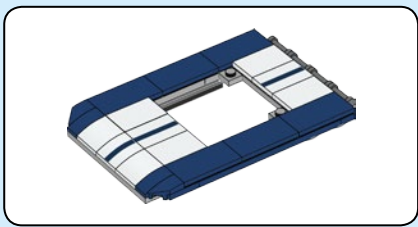

1x

288

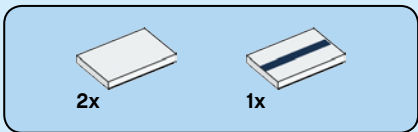
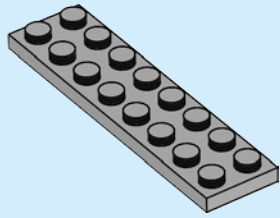

2x

1x

289

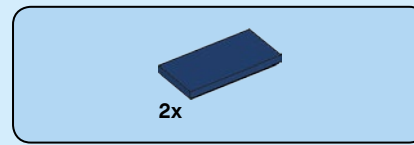
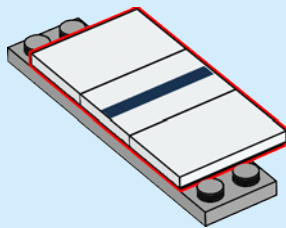

2x

290

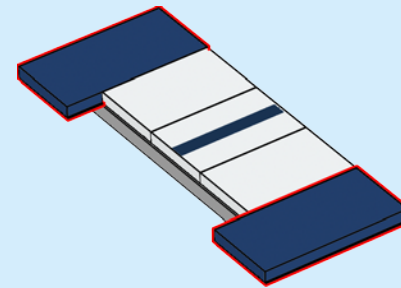

4x

291

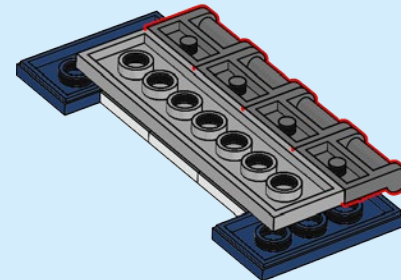
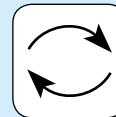

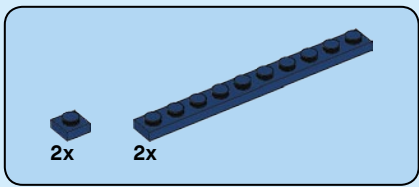

292

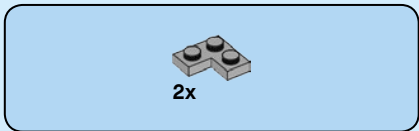
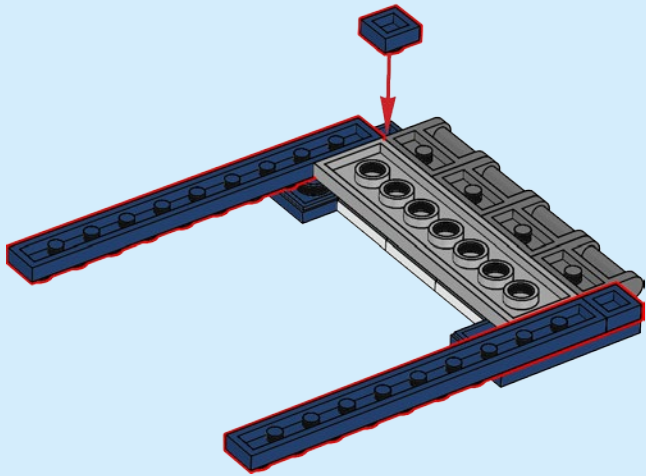

293

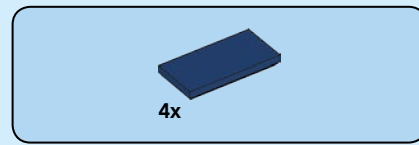
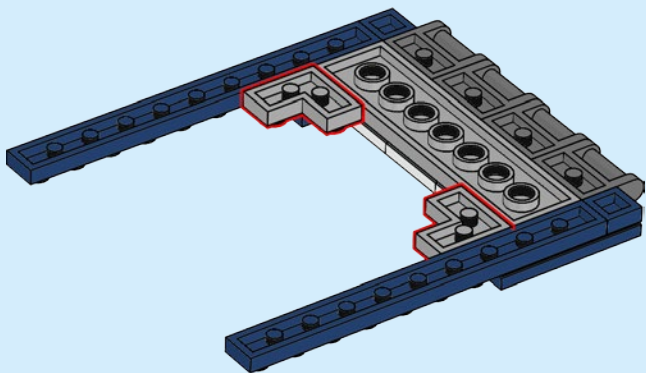

294

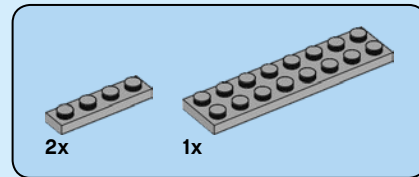
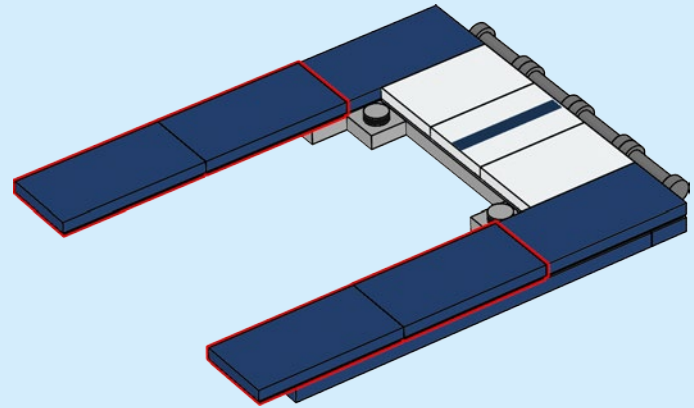
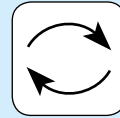

295

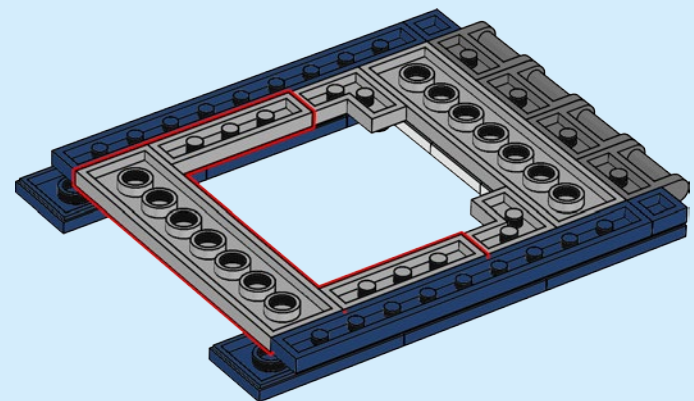
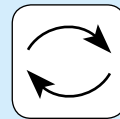

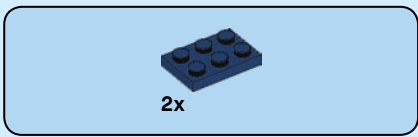

296

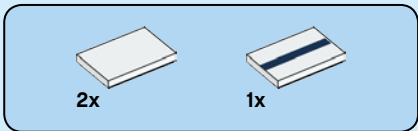
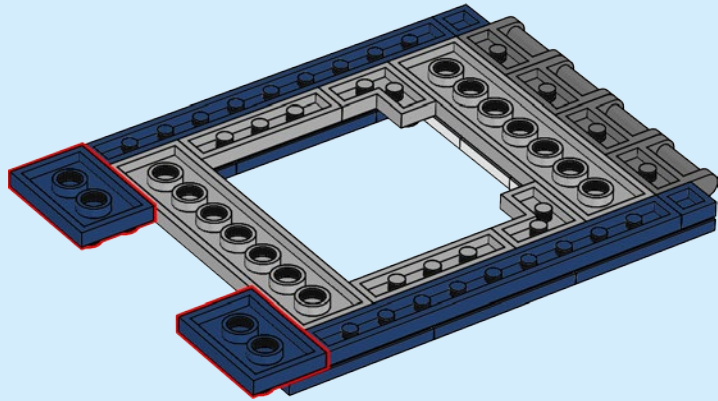

297

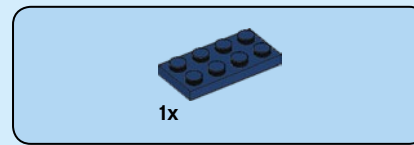
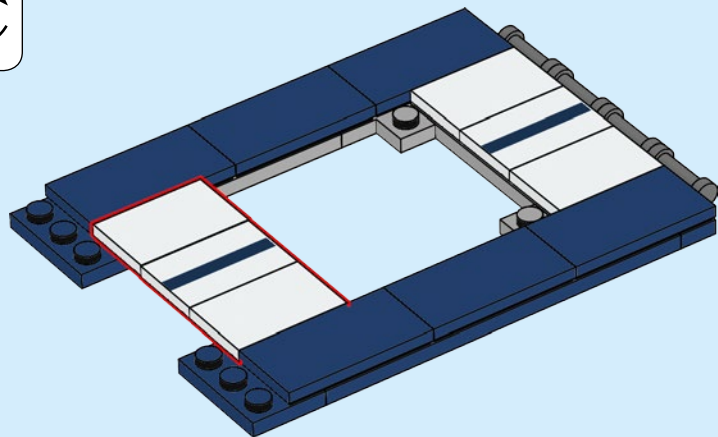
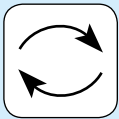

298

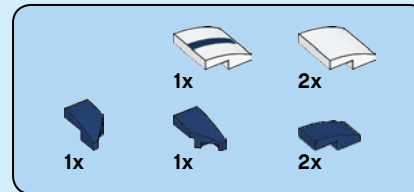
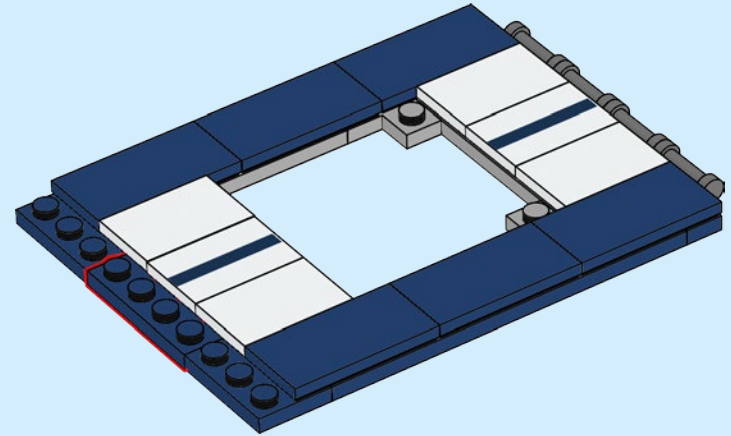

299

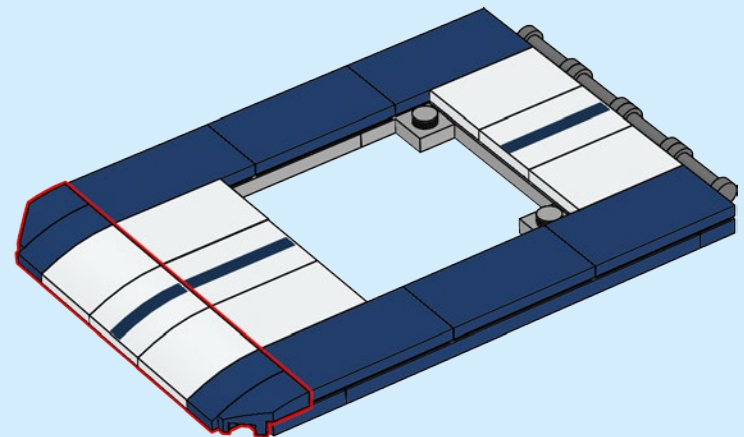

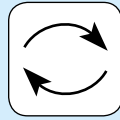
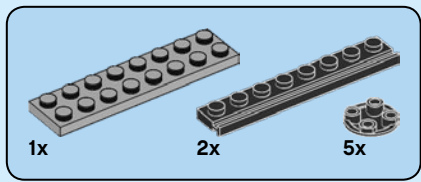

300

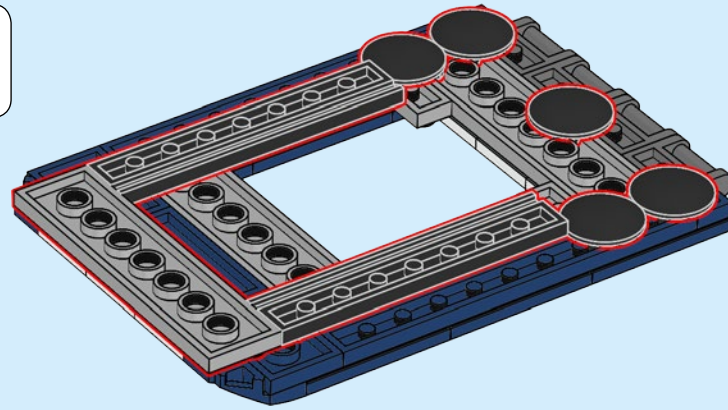

301

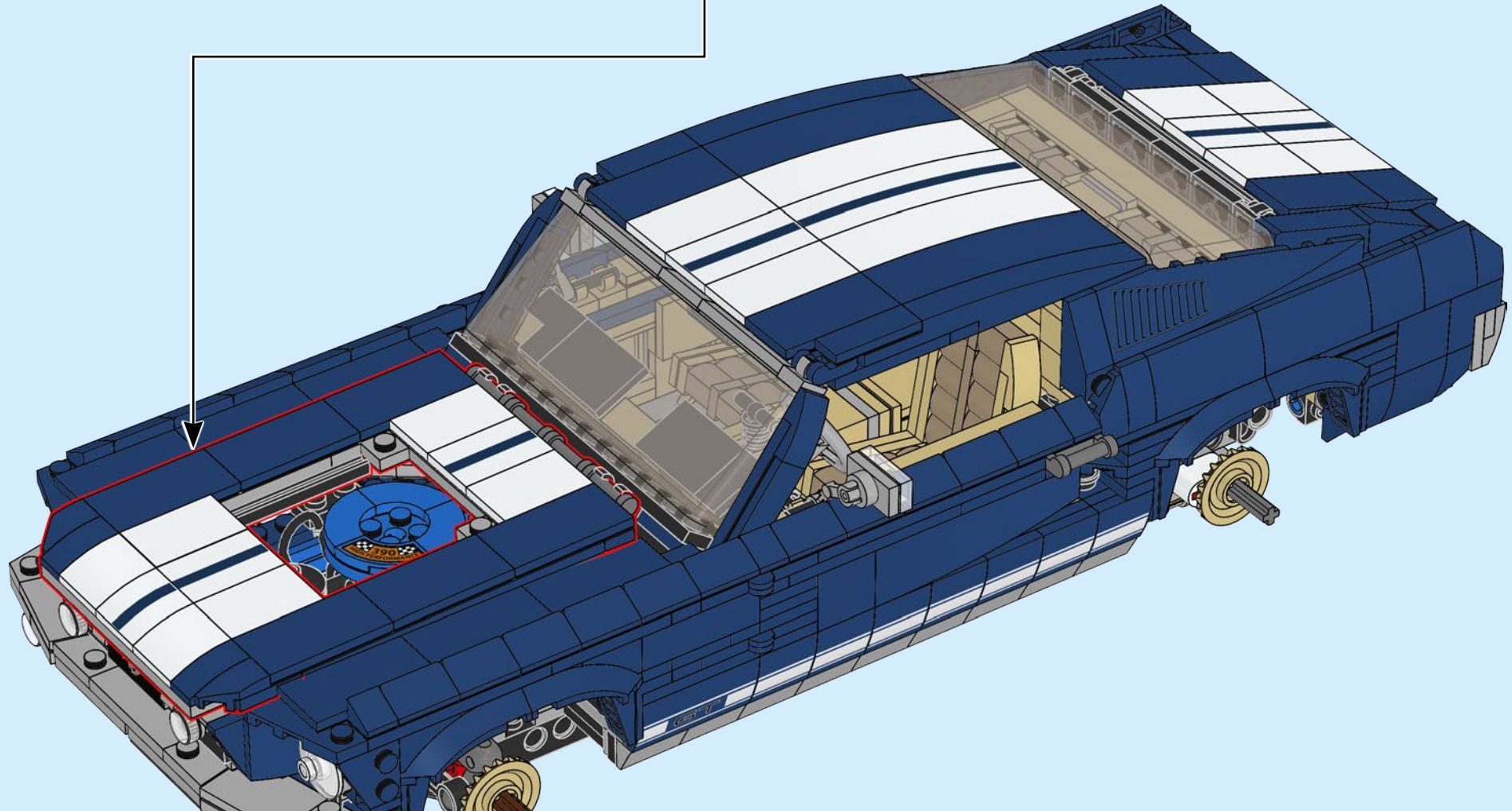

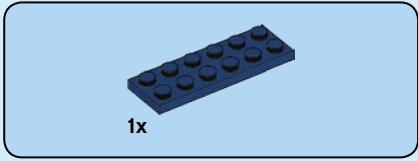
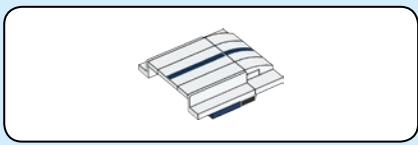

302

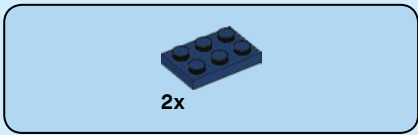
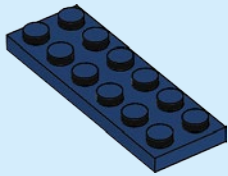

303

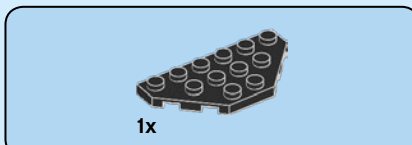
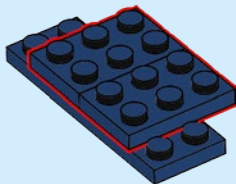

304

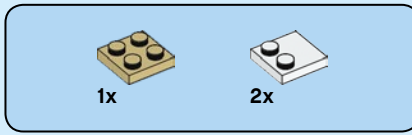
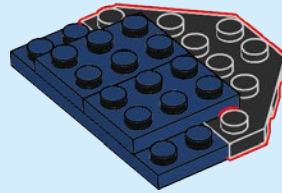

305

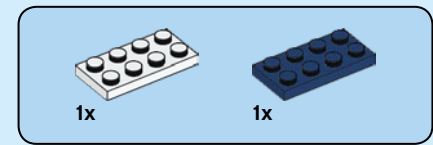
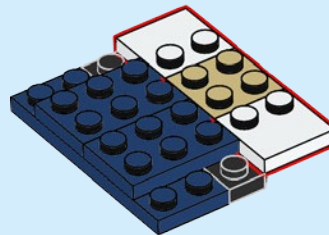

306

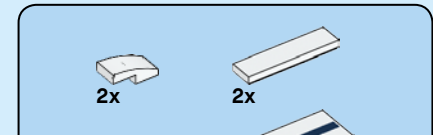
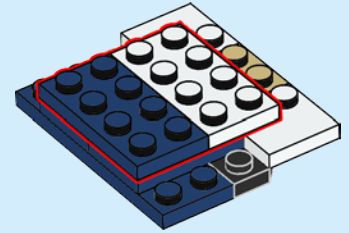

307

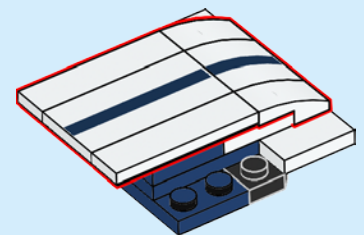

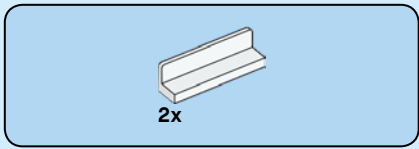

308

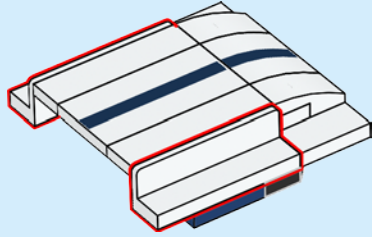

309

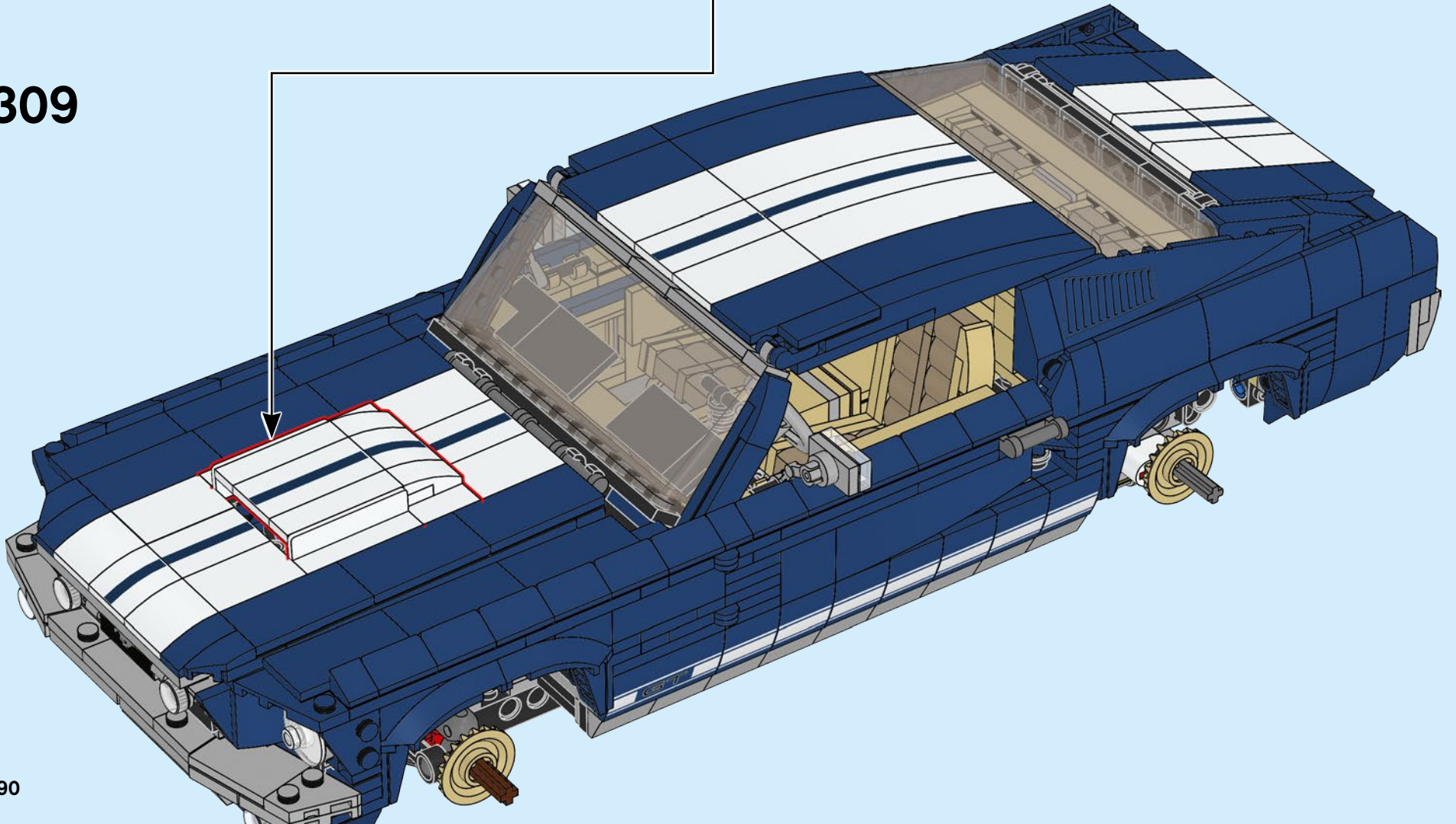

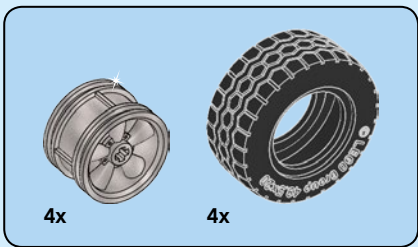

310

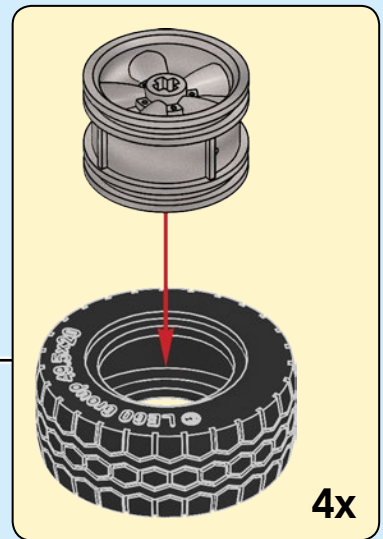
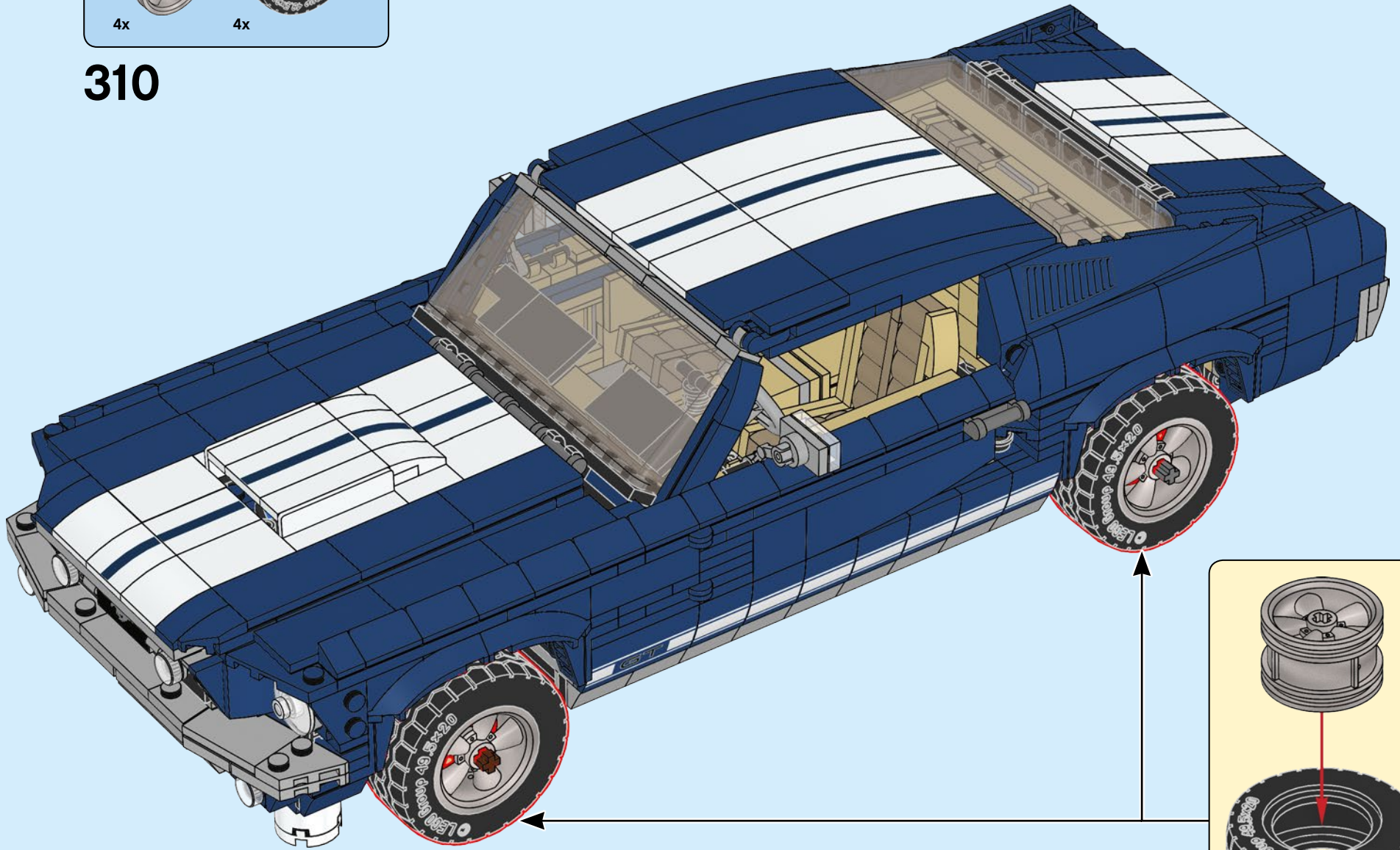



4x

311

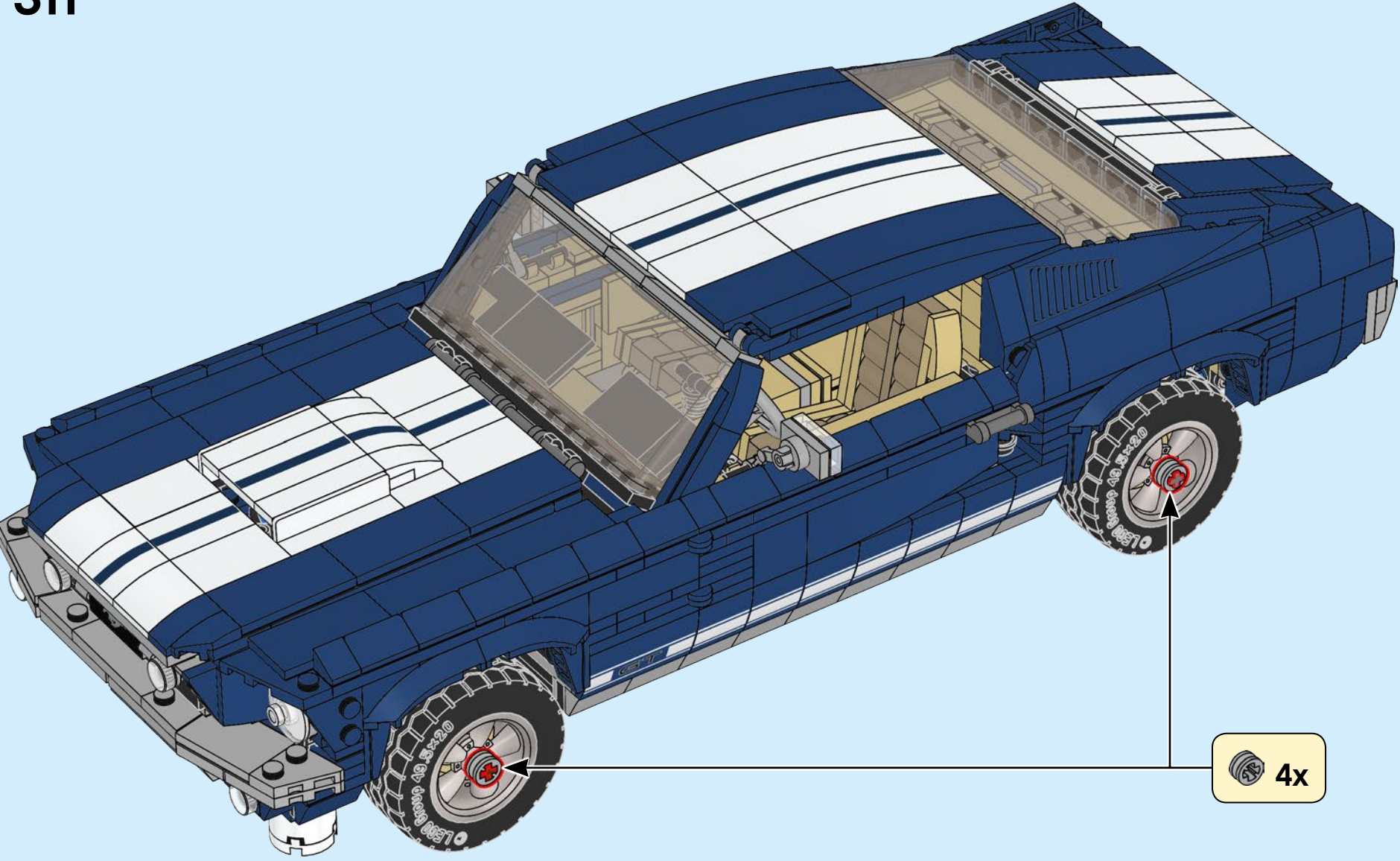

4x

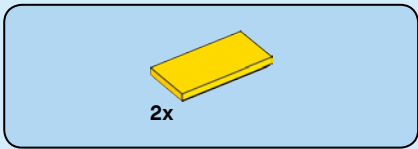

312

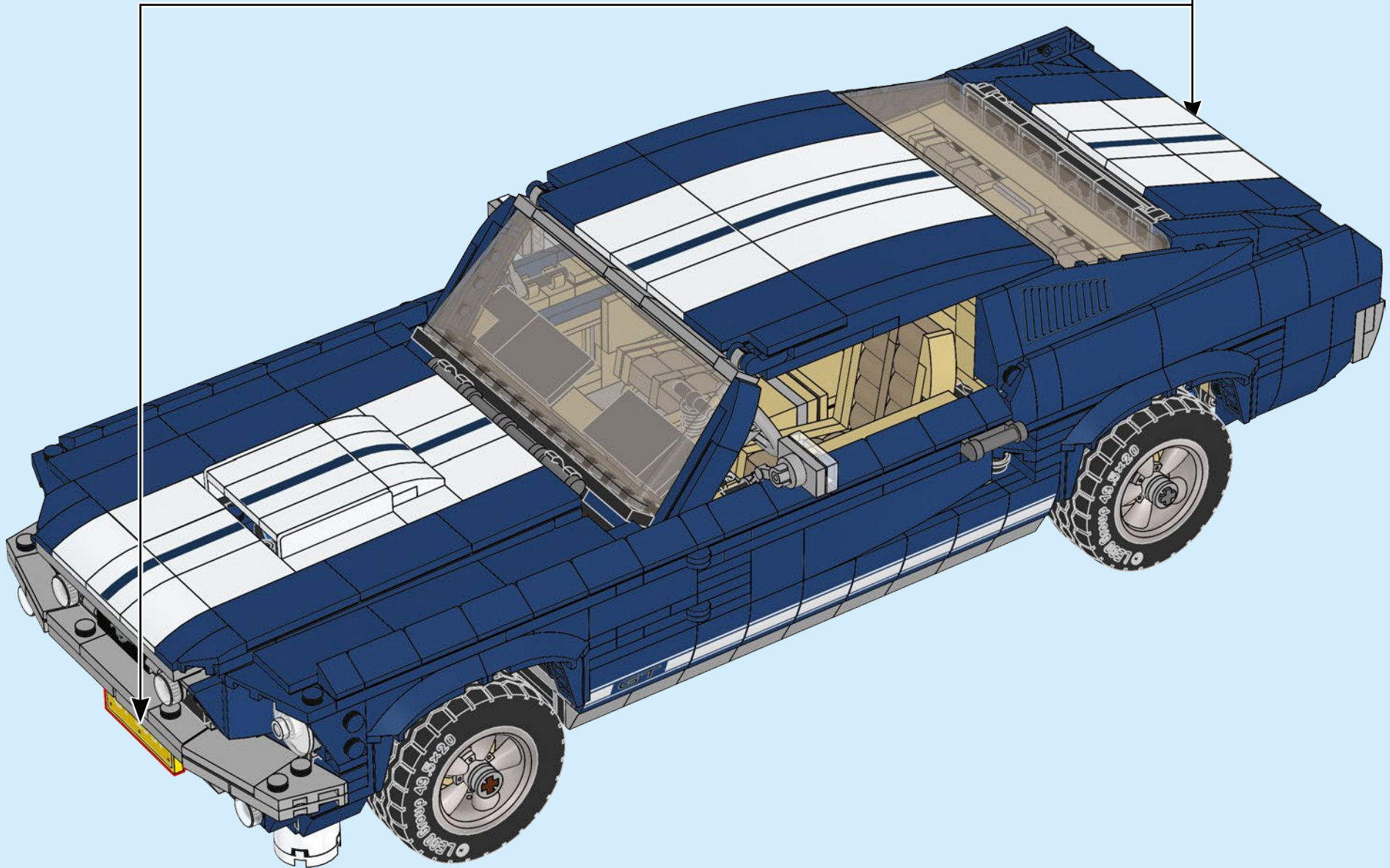
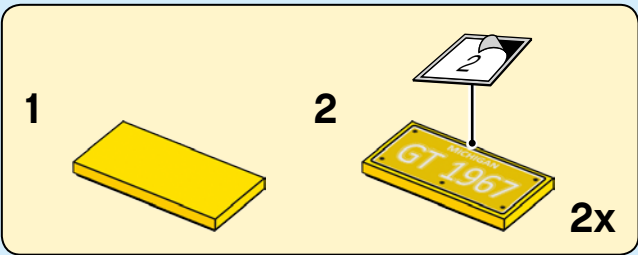

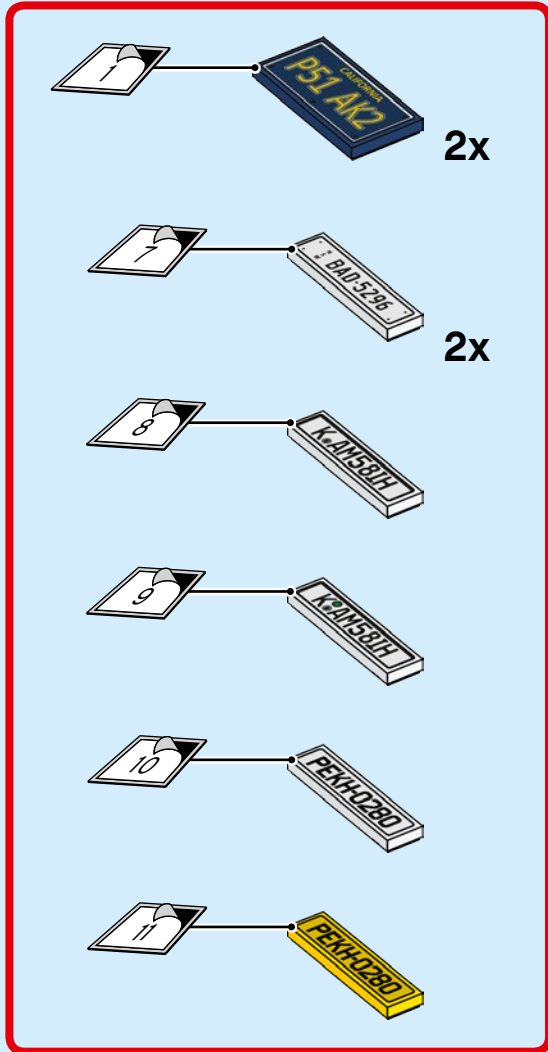
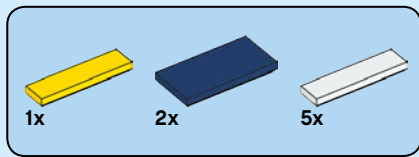

The first Mustang sold was only ever intended to be a demo model - but Eastern Airlines pilot Stanley Tucker convinced a dealer in Canada to sell it to him. Ford were able to reacquire the car after two years... in exchange for the millionth Mustang made.

La première Mustang vendue était censée n'être qu'un modèle de démonstration, mais le pilote d'Eastern Airlines Stanley Tucker a convaincu un concessionnaire canadien de la lui vendre. Ford a pu racheter la voiture après deux ans... en échange de la millionième Mustang fabriquée.

El primer Mustang que se vendió era sólo un modelo de demostración: Stanley Tucker, piloto de Eastern Airlines, convenció a un distribuidor de Canadá para que se lo vendiera. Ford pudo recuperar el auto después de dos años... a cambio del Mustang número un millón.

313

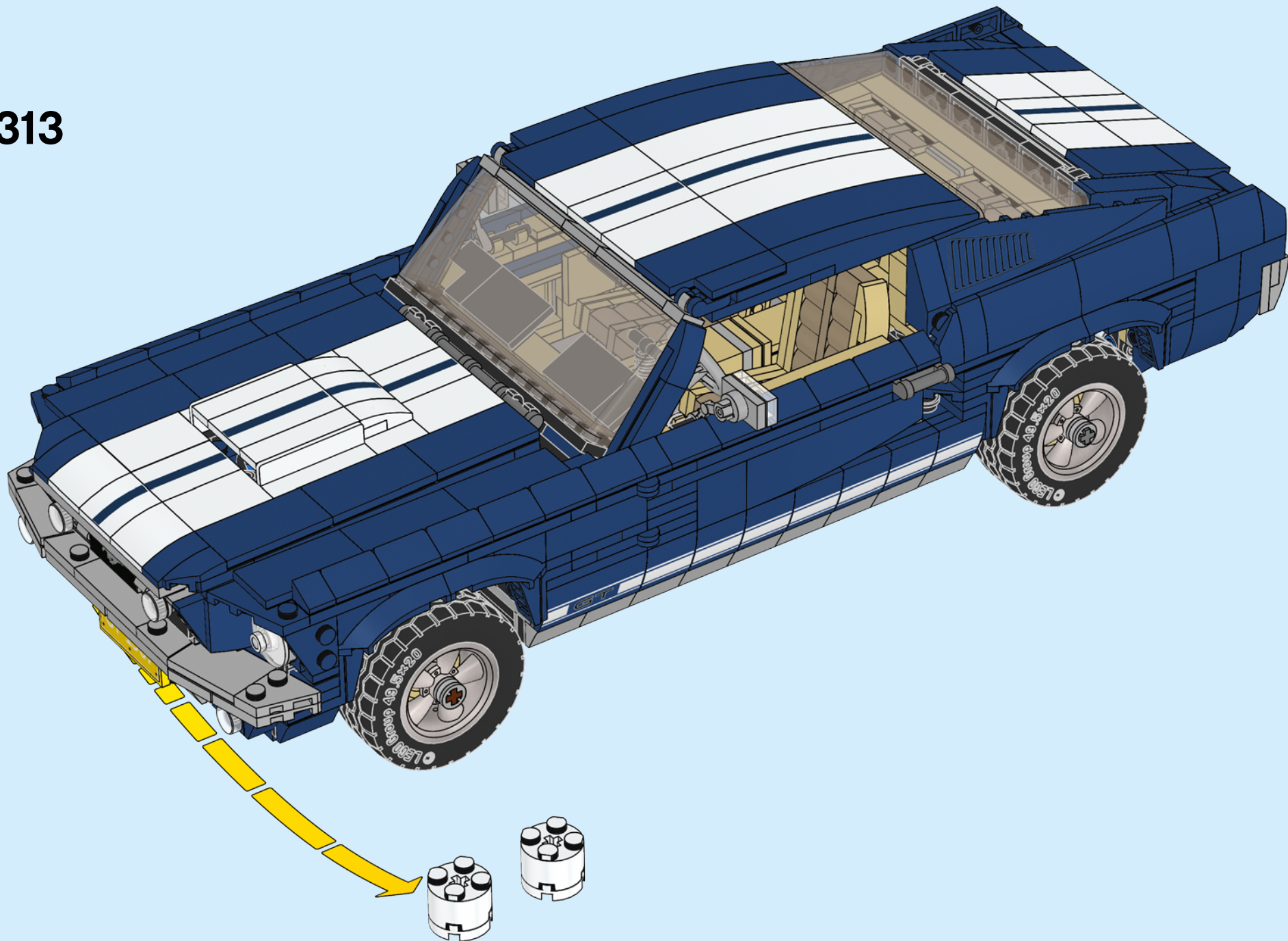

POWER UP YOUR MUSTANG!

Six ways to customize your Mustang

DÉMARREZ VOTRE MUSTANG !

Six façons de personnaliser votre Mustang



1. Adjustable rear suspension
2. Shorty exhaust headers
3. Supercharger with scoop intake
4. Front splitter
5. Rear spoiler
6. Nitrous oxide tank

1. Suspension arrière réglable
2. Collecteurs d'échappement courts
3. Compresseur d'alimentation à buse d'admission
4. Becquet avant
5. Aileron arrière
6. Réservoir d'oxyde nitreux

¡ARRANCA TU MUSTANG!

Seis maneras de personalizar tu Mustang



1. Suspensión trasera ajustable
2. Colectores de escape cortos
3. Supercargador con toma de aire
4. Divisor delantero
5. Alerón trasero
6. Tanque de óxido nitroso

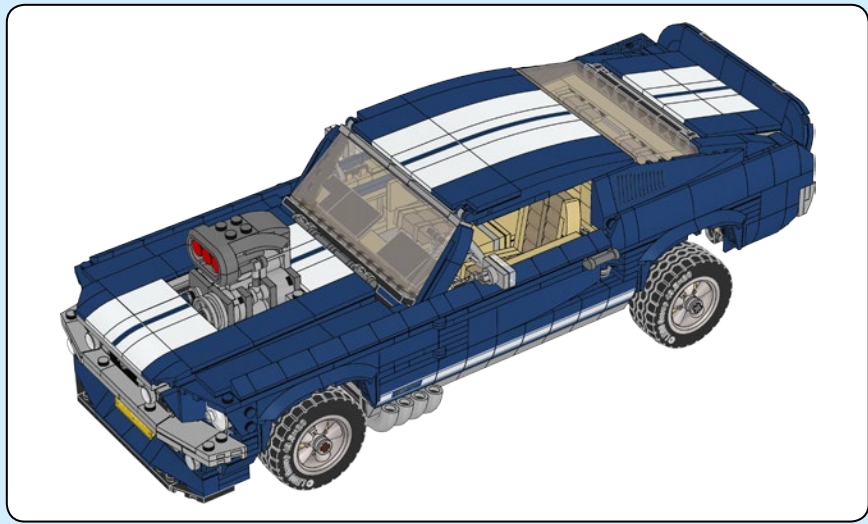

1

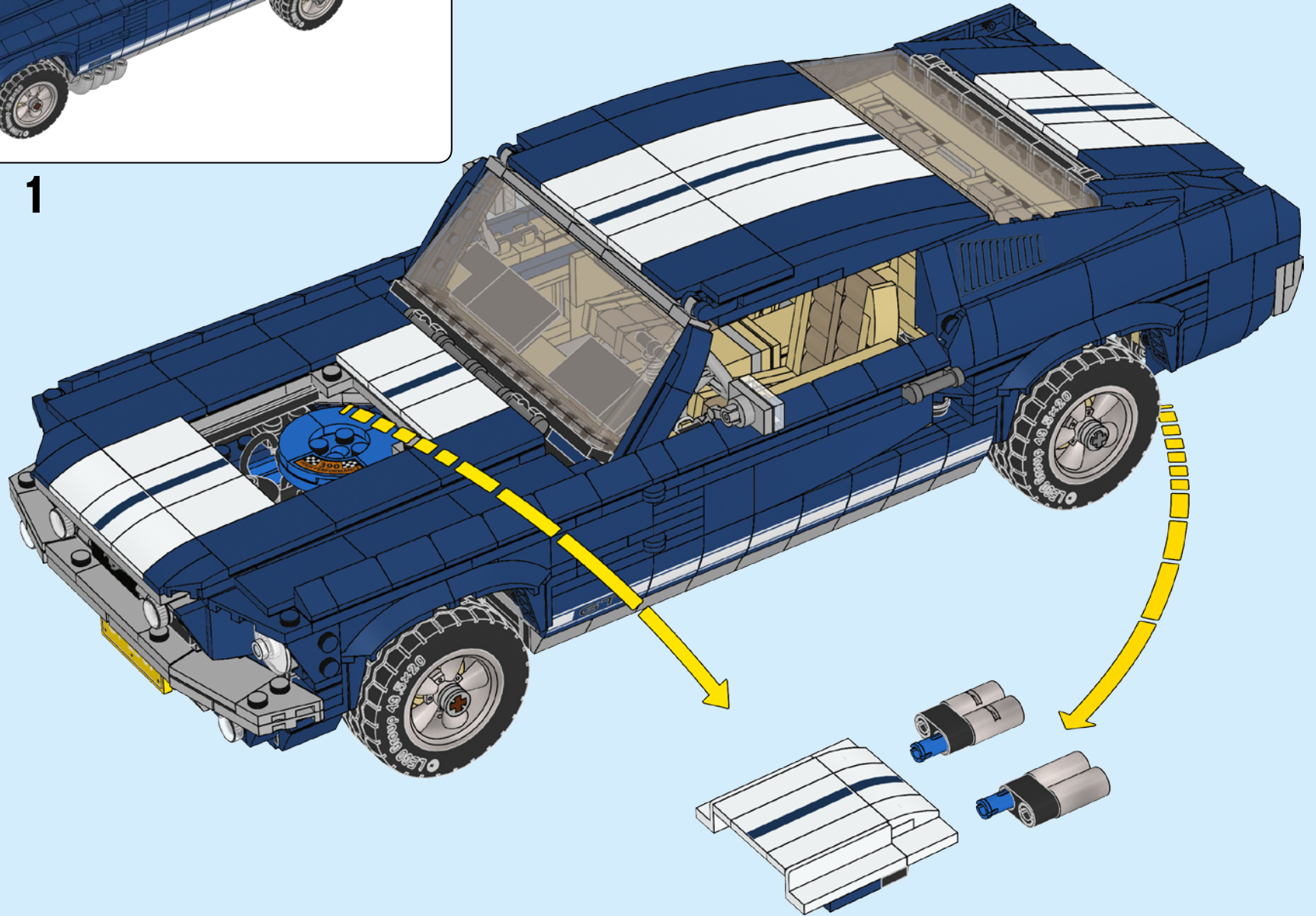

2

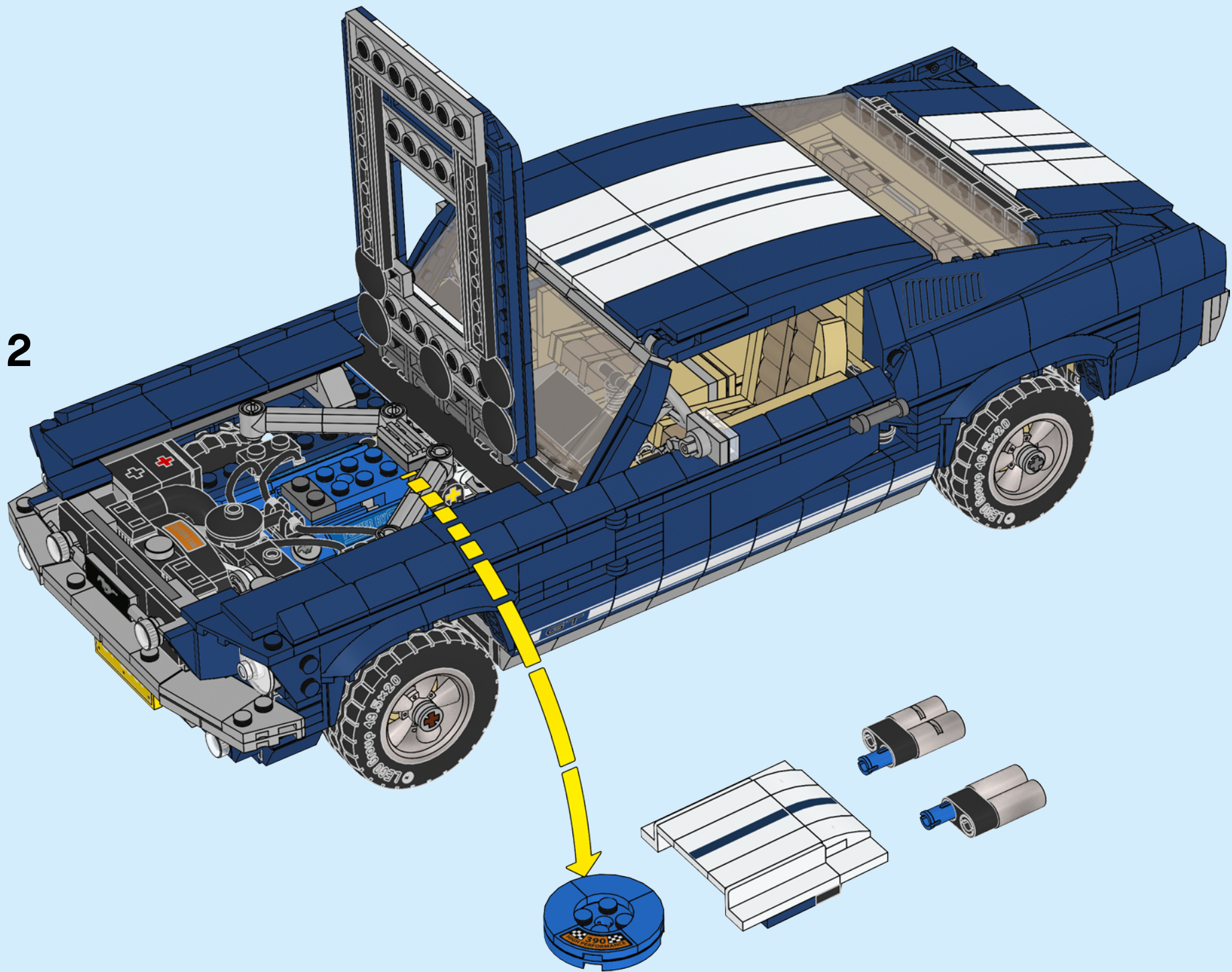

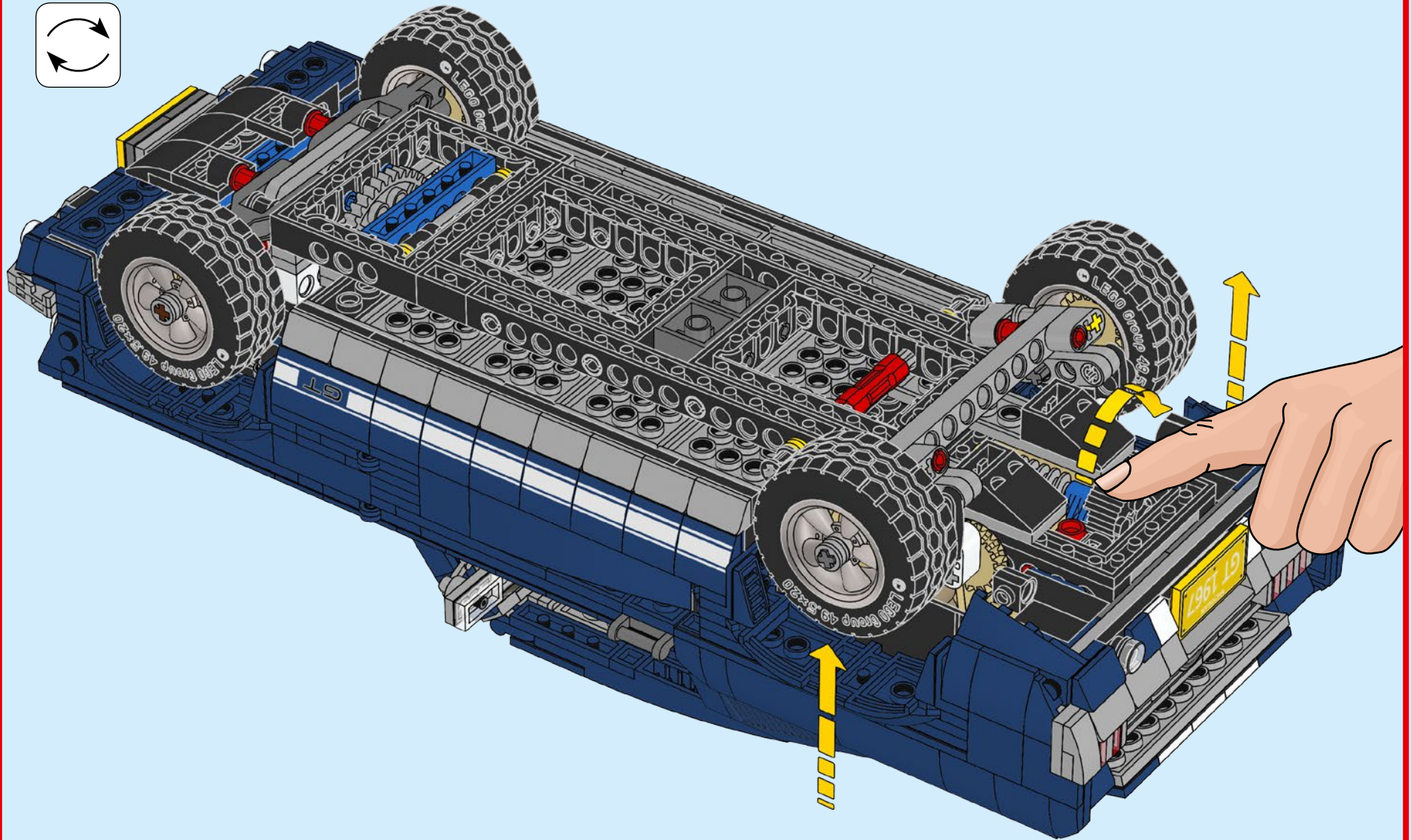
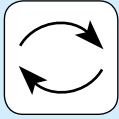

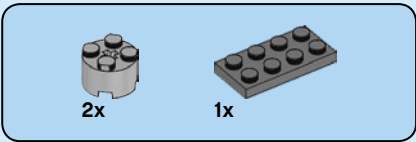
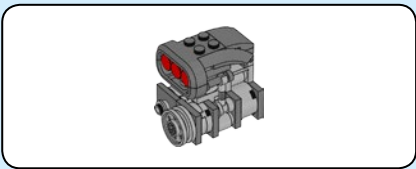

3

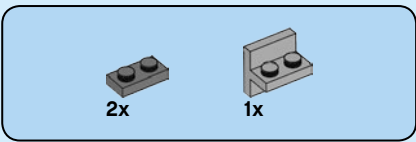
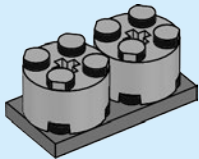

4

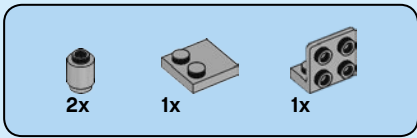
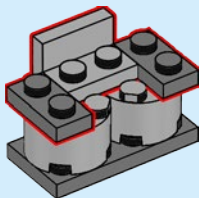

5

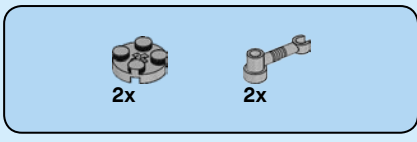
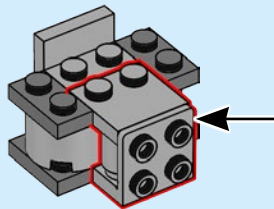
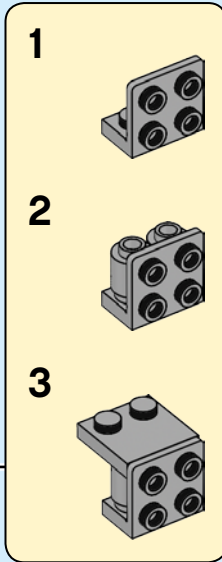

6

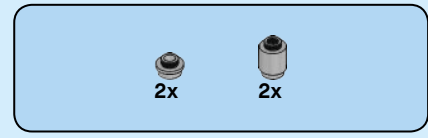
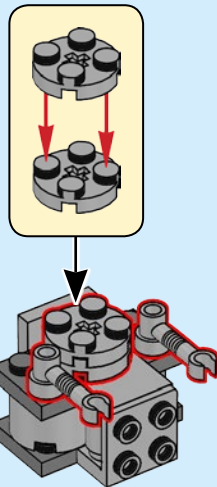

7

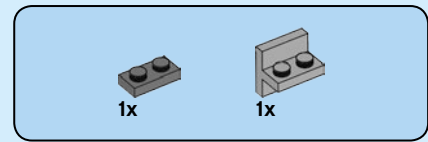
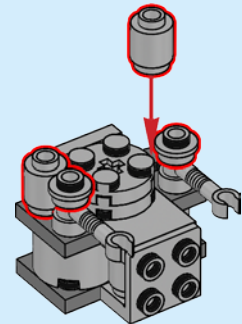

8

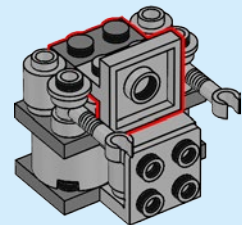

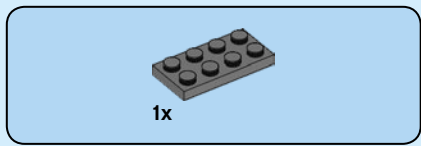

9

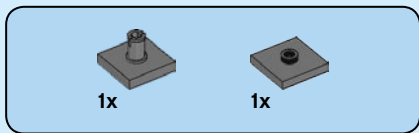
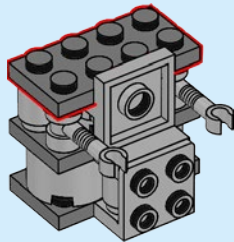

11

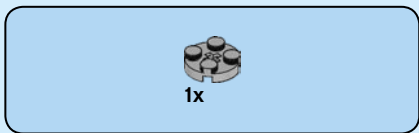
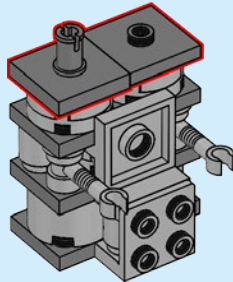

13

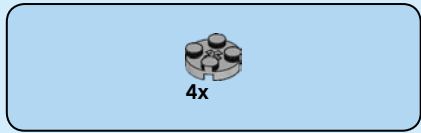
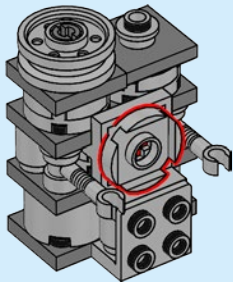

10

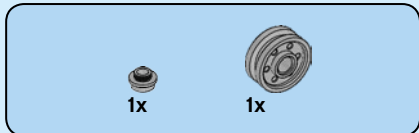
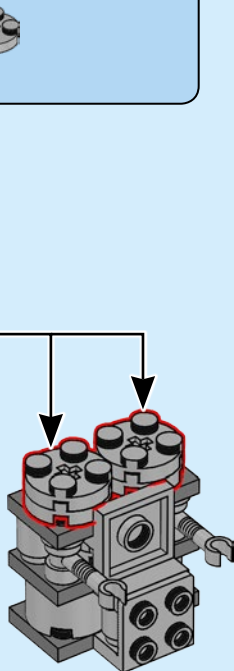

12

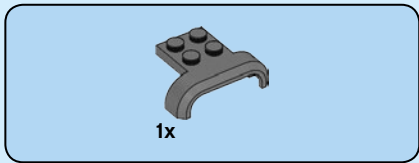
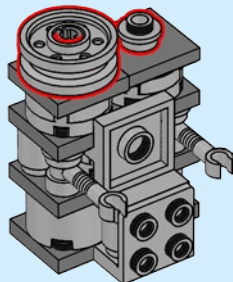

14

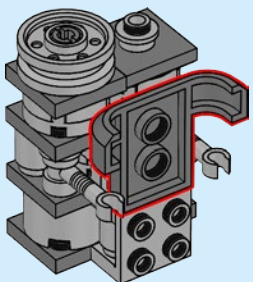

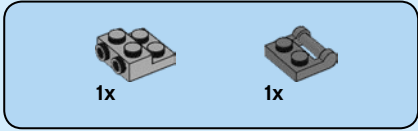
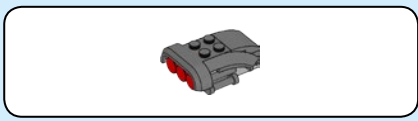

15

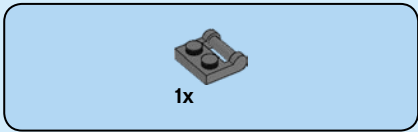
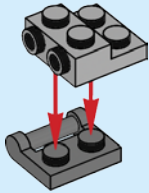

16

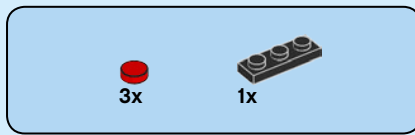
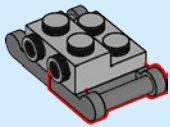

17

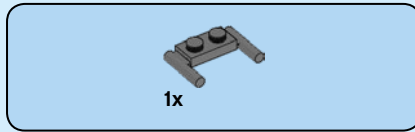
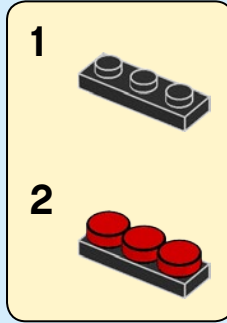

18

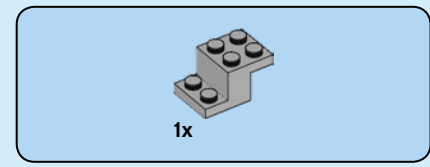
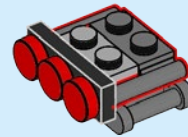

19

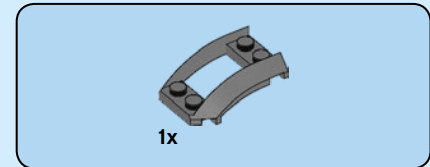
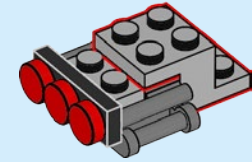

20

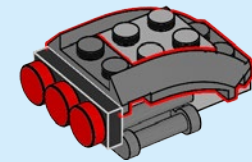



1x

21

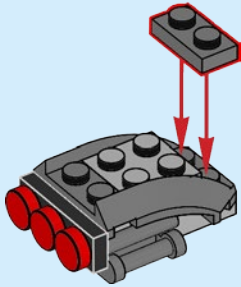

23

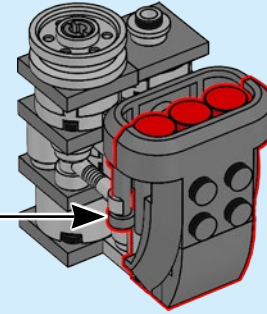

1x



1x

22



24

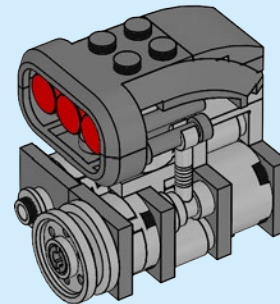
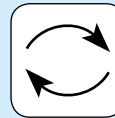

25

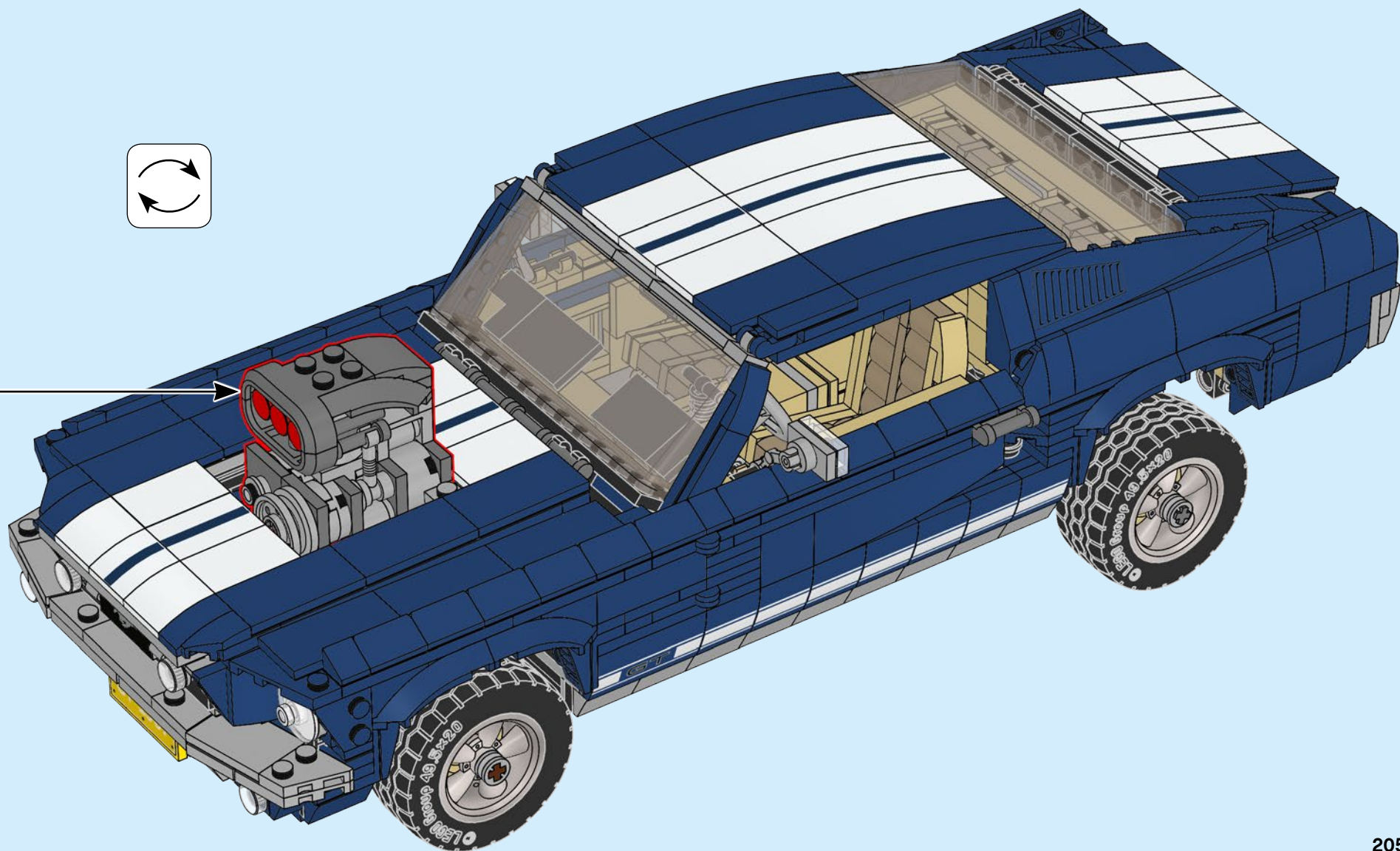
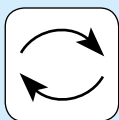

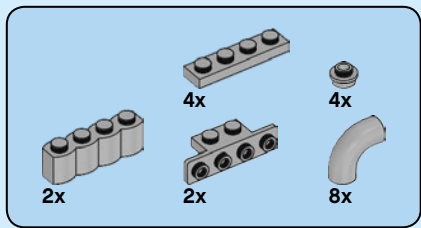

26

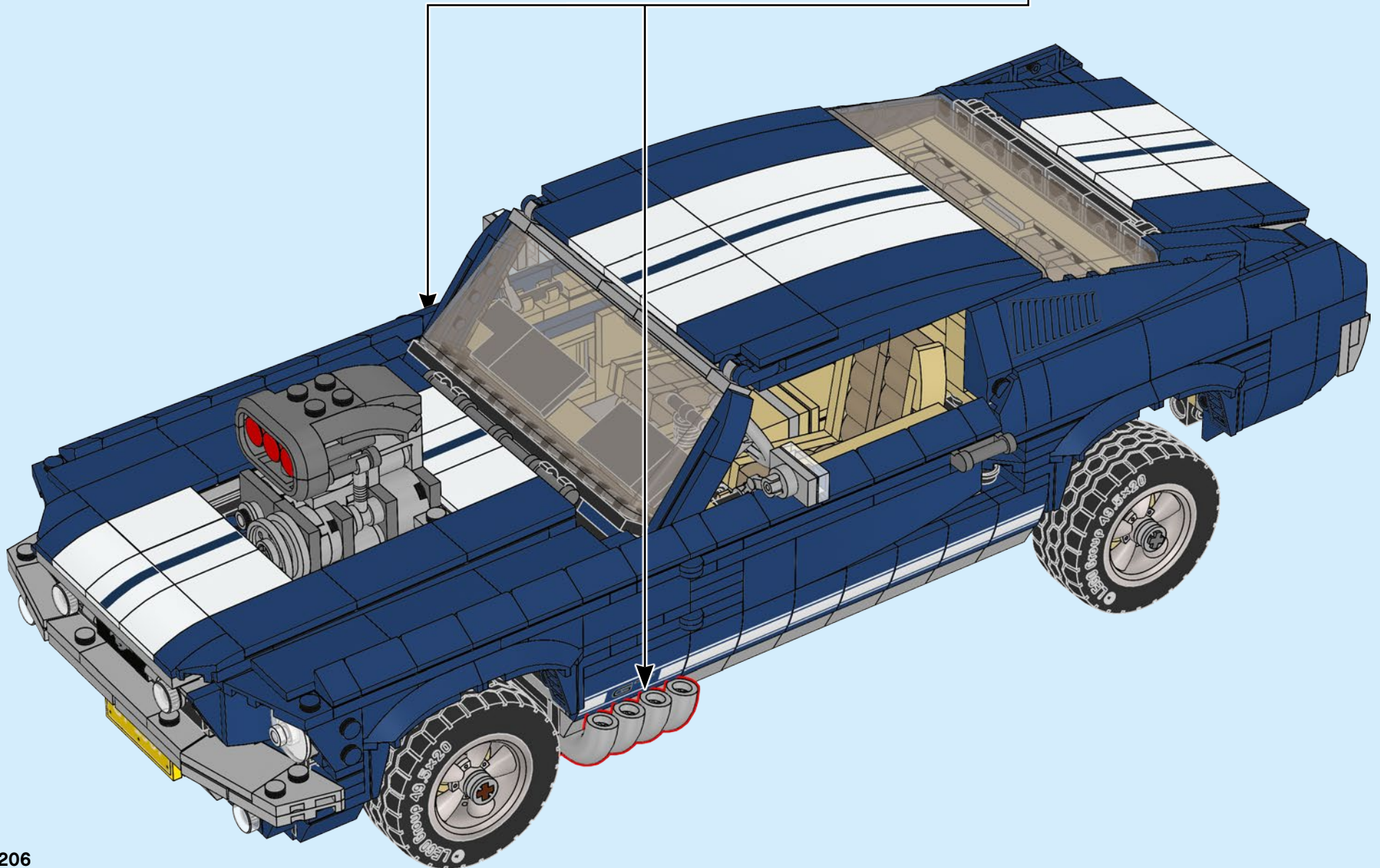
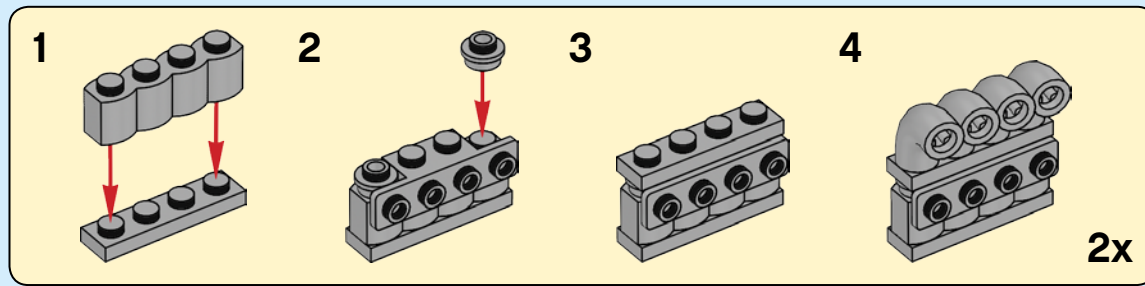

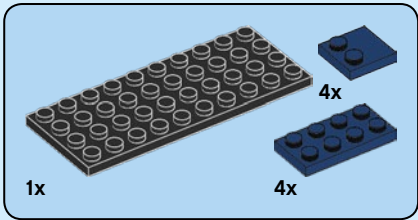
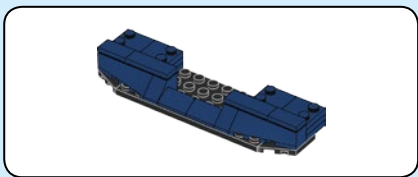

27

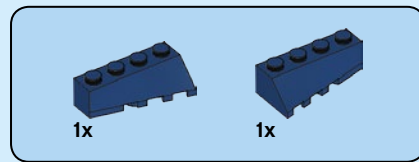
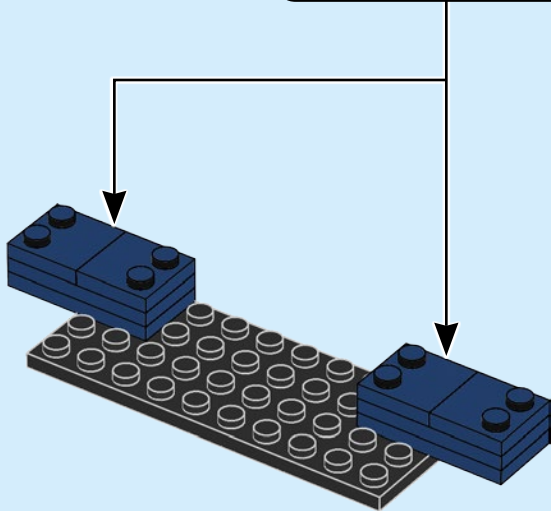
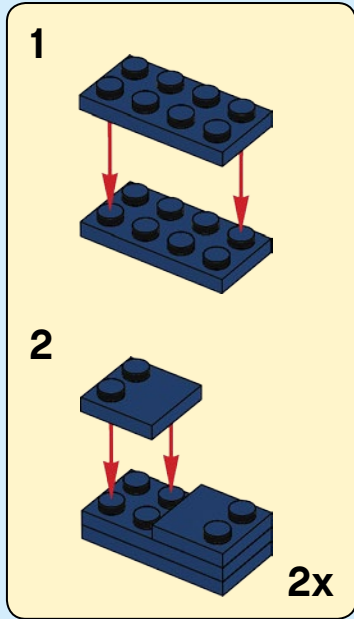

28

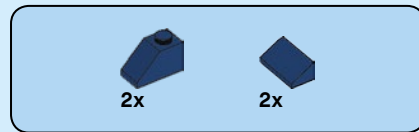
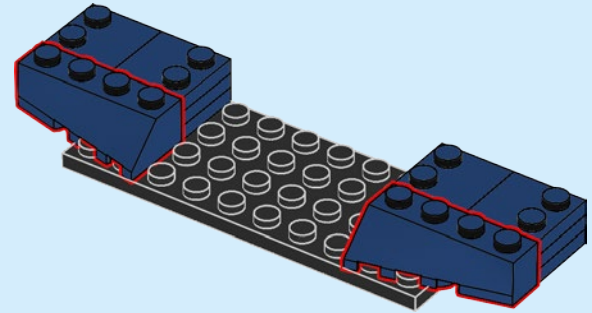

29

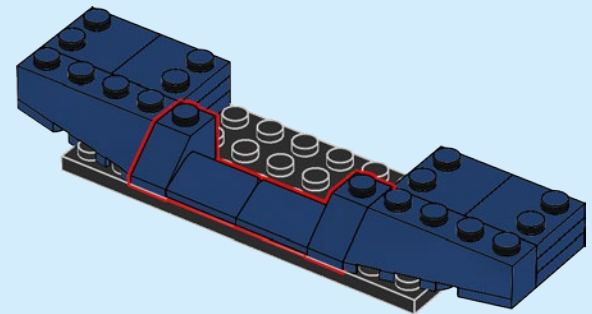

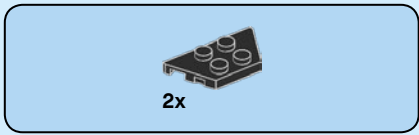

30

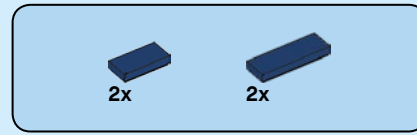
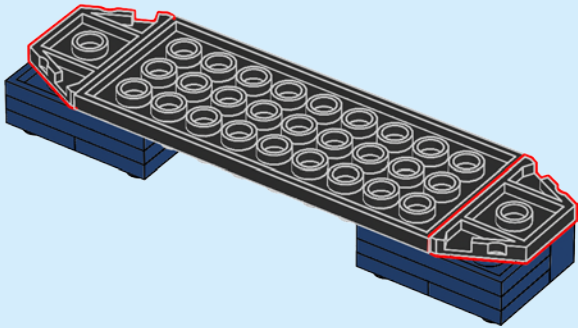
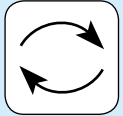

31

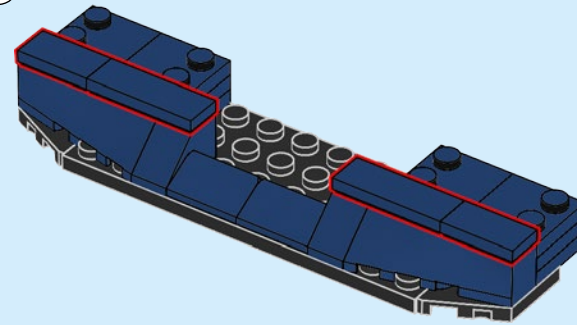
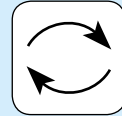

32

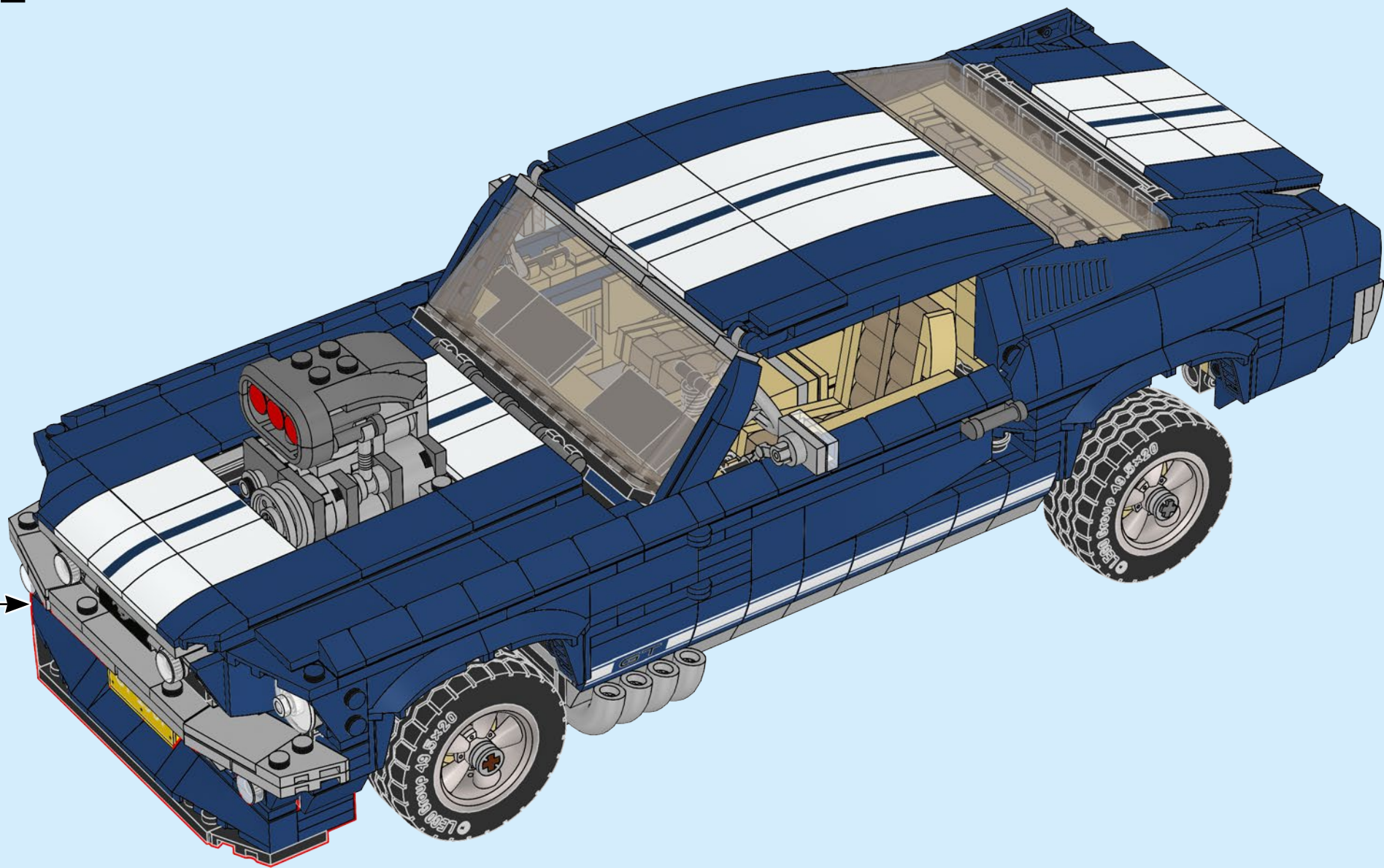

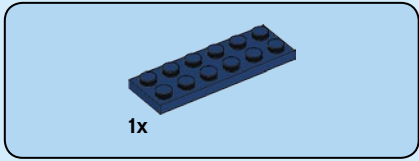
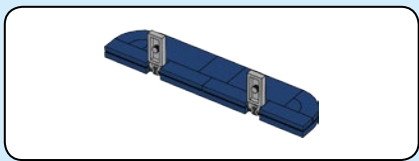

33

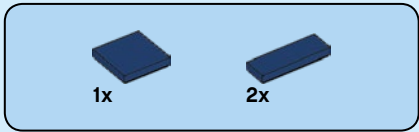
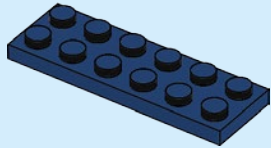

34

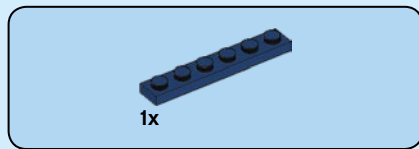
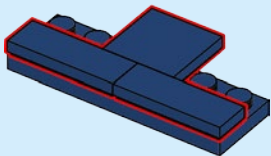

35

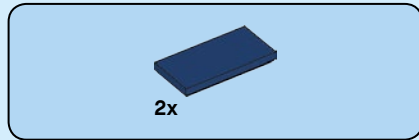
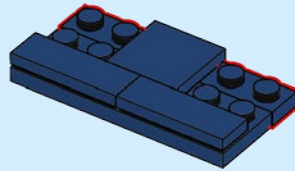

36

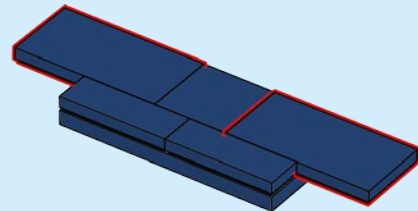

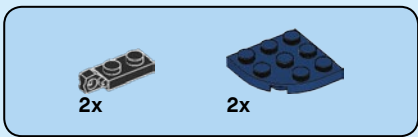

37

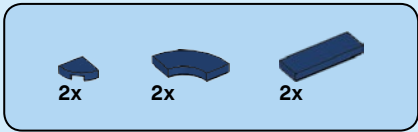
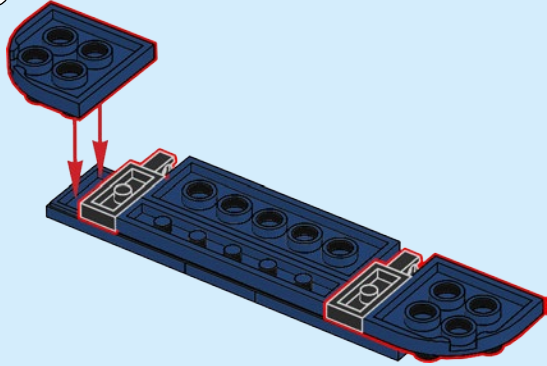
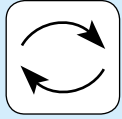

38

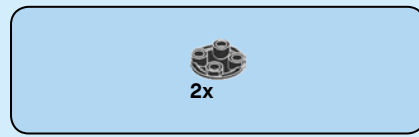
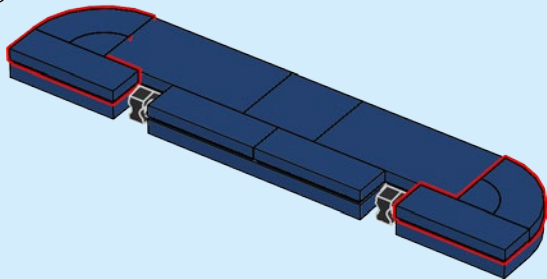
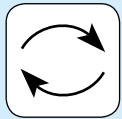

39

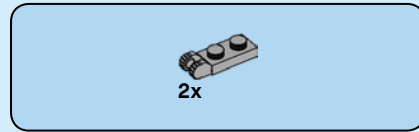
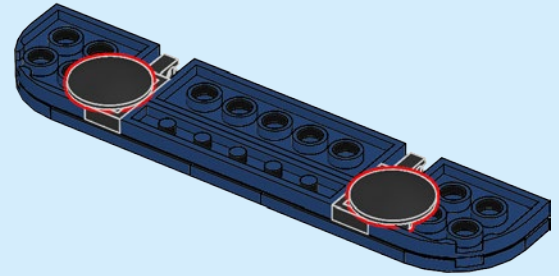
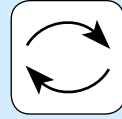

40

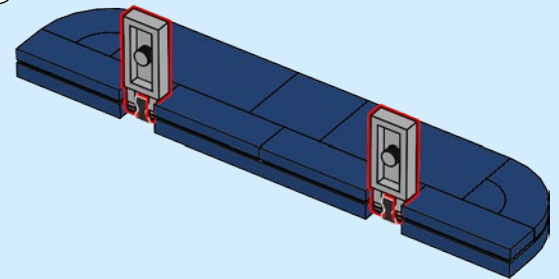
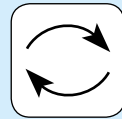

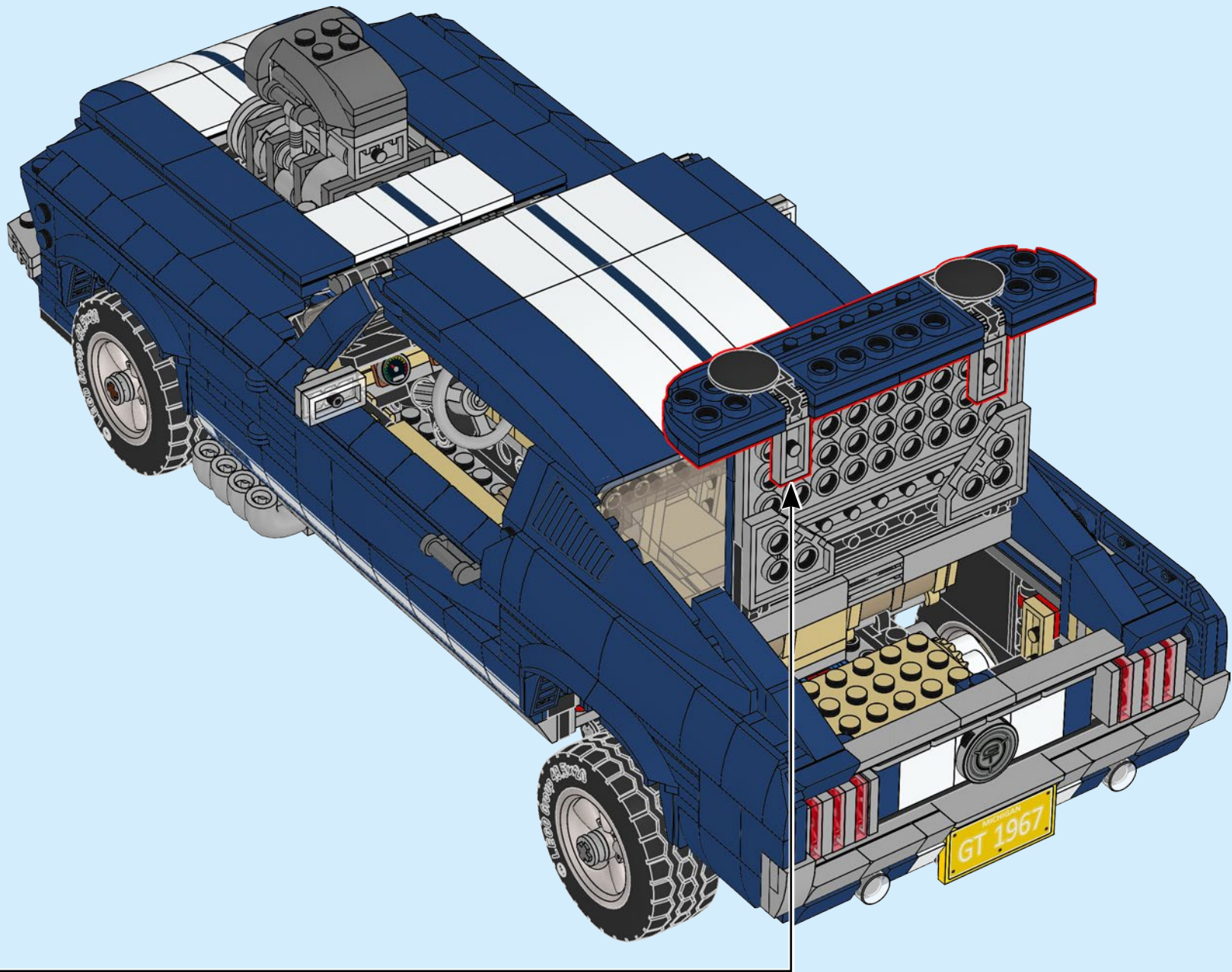

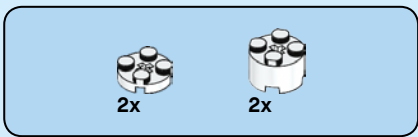

42

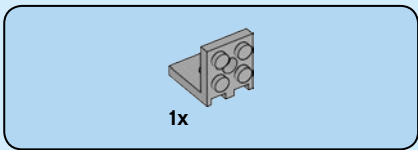
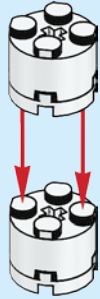

43

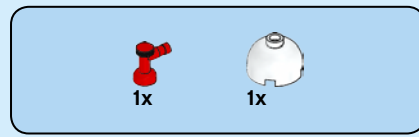
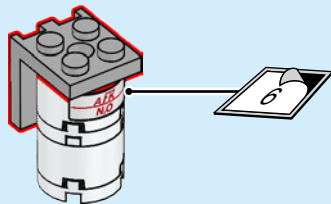

44

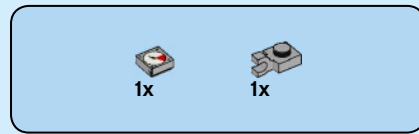
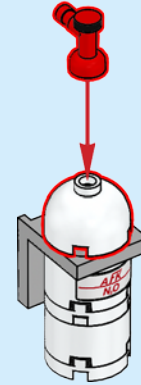

45

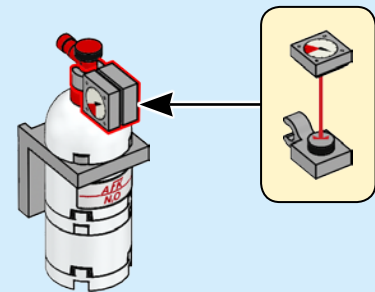

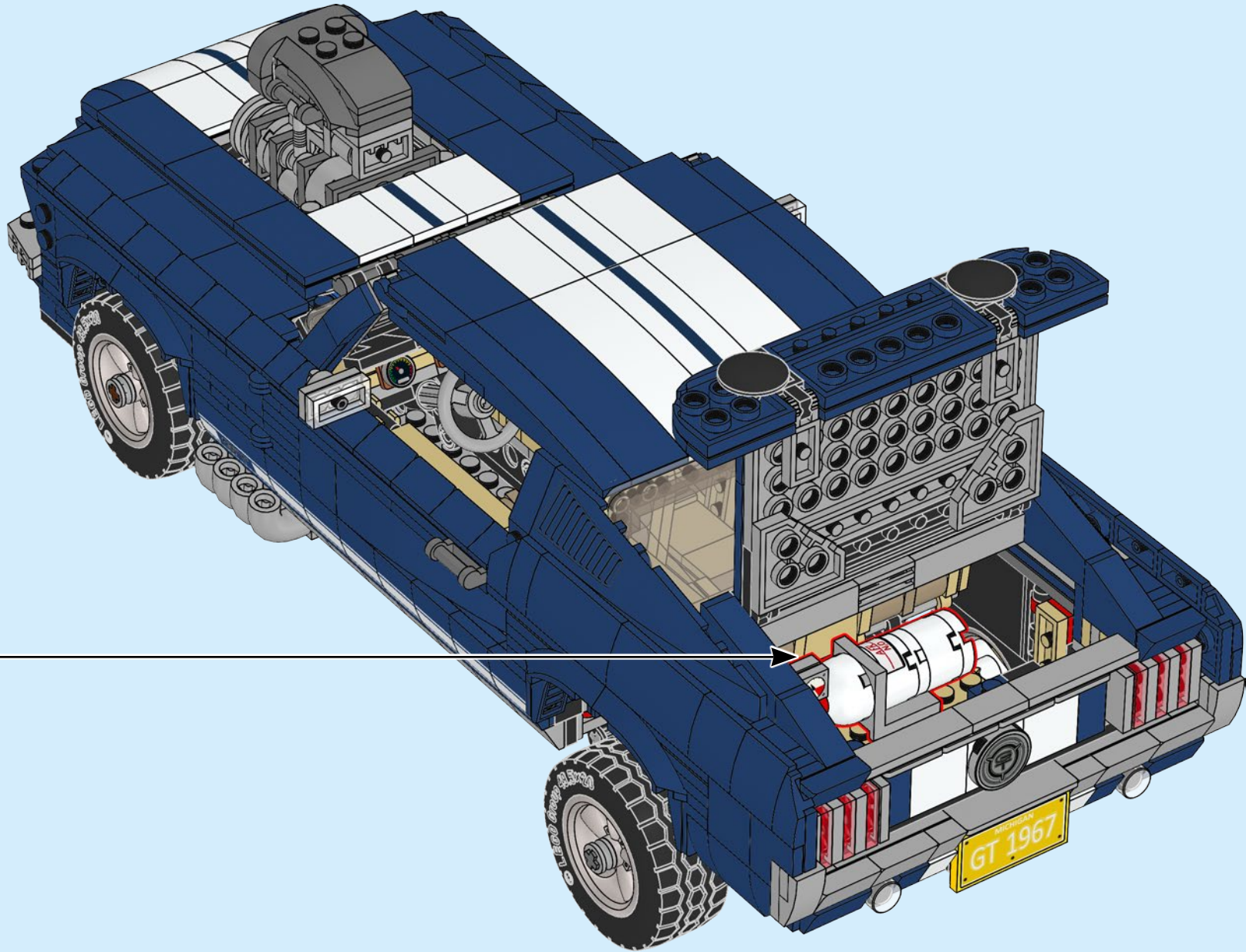



CREATOR™



LEGO.com/creatorexpert



EXPERT



10261



CREATOR™

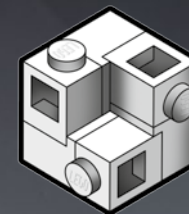

EXPERT

LICENCE TO BUILD PERMIS DE CONSTRUIRE LICENCIA PARA CONSTRUIR



10262



ASTON MARTIN

007™

007™ and James Bond materials © 1962-2018 Danjaq and MGM.
007™ and related James Bond Trademarks,™ Danjaq. All rights reserved.

2x 4504369
2x 4544140
2x 403201
1x 4216652
2x 614301
4x 6177268
6x 3200001
1x 6051511
2x 6034044
2x 6047220
2x 6218822
2x 306801
2x 6258166
1x 302201
4x 242001
4x 362301
4x 6258380
8x 6156667

7x 243101
2x 6061047
2x 6258071
1x 302001
2x 4560178
2x 6253935
1x 6258674
6x 6252969
2x 4179771
4x 4516055
6x 4159553
2x 6057517
4x 6232135
8x 6029889
2x 4666579
2x 6232037

9x 4109995
4x 6024495
2x 6046922
5x 4114026
2x 6251252
32x 4113917
1x 4612873
6x 6031962
6x 6013081
6x 6221467
4x 4114084
4x 6046924
1x 4185177
1x 6173638
8x 6132769
8x 4121921

6x 4550324
21x 4113233
2x 6195544
4x 6102772
5x 6122047
7x 4124067
2x 4157277
1x 4113988
1x 4125217
1x 6156462
1x 6075179
24x 614121
3x 6063445
1x 459921

3x 6130007
1x 4153707
7x 6271167
1x 370124
1x 243124
2x 4560181
2x 6130008
2x 307021
2x 4524644
2x 4186678
6x 4142865
2x 4118897
2x 6053011
6x 6209519
6x 4140806
1x 6273211
1x 6129995

9x 4206482
6x 393723
1x 6092582
1x 306923
2x 6179330
2x 6212141
2x 4195007
4x 6194724
6x 4514553
2x 243123
1x 4212411
1x 4581501
1x 300123
1x 6171063
4x 366623
1x 389423

10x 614126
1x 6073231
2x 4560174
4x 6066102
2x 6187572
6x 6234695
2x 4184169
1x 6104209
1x 4143372
7x 4278359
1x 4109810
2x 4548180
1x 6024730
1x 474026
1x 6179182
2x 4632571
37x 4121715

1x 6195325
2x 4107081
5x 287726
2x 4177444
10x 4598528
4x 4569733
3x 4121966
5x 6092585
2x 6114987
4x 6192309
2x 6156991
6x 6178922
5x 6016172
5x 4556158
2x 6055630
2x 6116990
3x 4107761

2x 4288212
2x 6093525
2x 4183043
4x 306826
3x 6211476
4x 4565323
4x 6192346
2x 6061032
3x 300326
2x 303926
2x 6133722
2x 6089119
6x 235726
5x 4515368
2x 4121667
2x 412822
6x 362326

1x 6199908
2x 4531412
2x 6162892
2x 300226
2x 374726
1x 4613153
2x 6030286
4x 302026
2x 4629921
1x 241926
3x 379526
2x 4653049
4x 6055626
2x 4495935

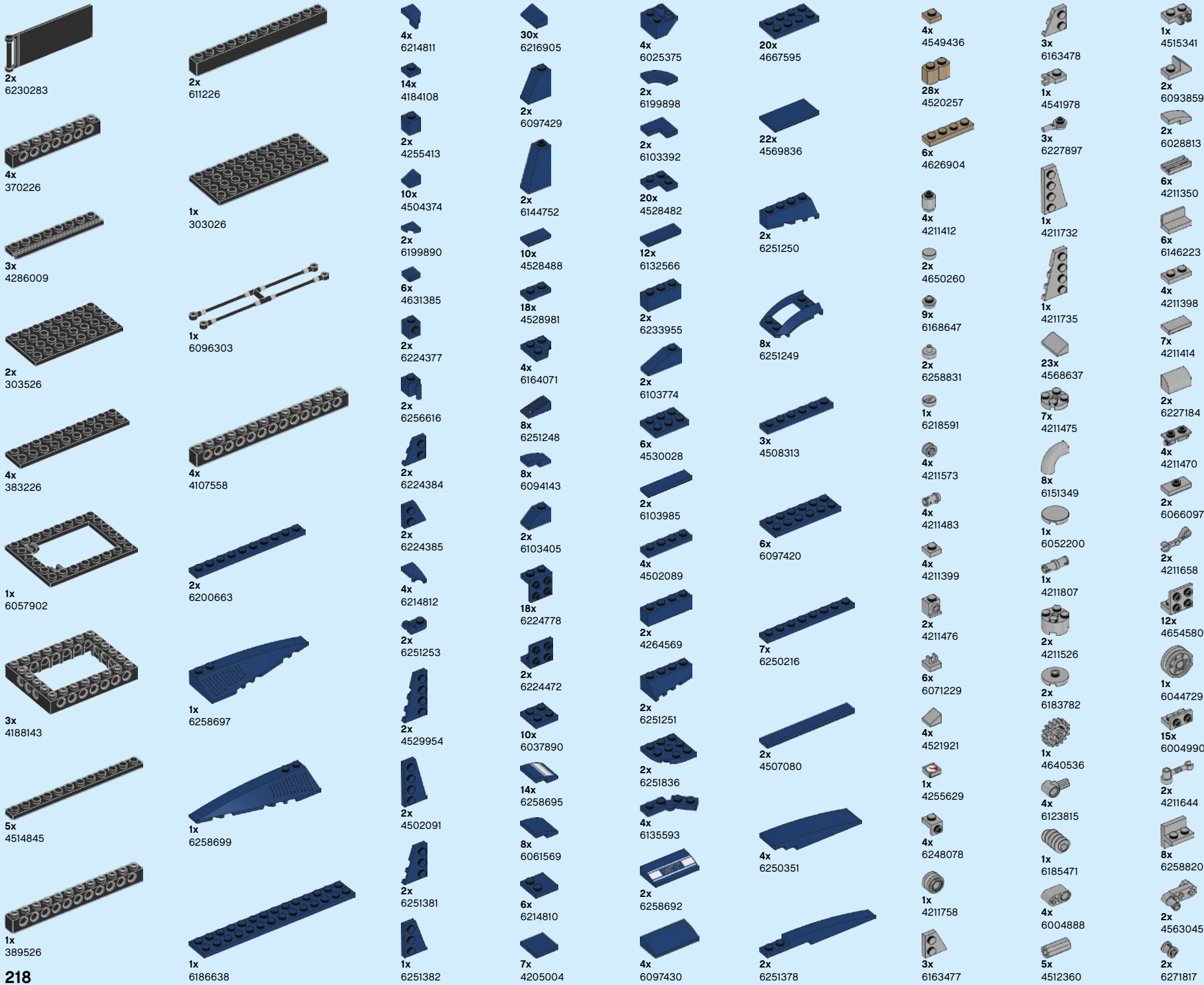

2x 6230283
4x 370226
3x 4286009
2x 303526
4x 383226
1x 6057902
3x 4188143
5x 4514845
1x 389526

2x 611226
1x 303026
1x 6096303
4x 4107558
2x 6200663
1x 6258697
1x 6258699
1x 6186638

4x 6214811
14x 4184108
2x 4255413
10x 4504374
2x 6199890
6x 4631385
2x 6224377
2x 6256616
2x 6224384
2x 6224385
4x 6214812
2x 6251253
2x 4529954
2x 4502091
2x 6251381
1x 6251382

30x 6216905
2x 6097429
2x 6144752
10x 4528488
18x 4528981
4x 6164071
8x 6251248
8x 6094143
2x 6103405
18x 6224778
2x 6224472
10x 6037890
14x 6258695
8x 6061569
6x 6214810
7x 4205004

4x 6025375
2x 6199898
2x 6103392
20x 4528482
12x 6132566
2x 6233955
2x 6103774
6x 4530028
2x 6103985
4x 4502089
2x 4264569
2x 6251251
2x 6251836
4x 6135593
2x 6258692
4x 6097430

20x 4667595
22x 4569836
2x 6251250
8x 6251249
3x 4508313
6x 6097420
7x 6250216
2x 4507080
4x 6250351
2x 6251378

4x 4549436
28x 4520257
6x 4626904
4x 4211412
2x 4650260
9x 6168647
2x 6258831
1x 6218591
4x 4211573
4x 4211483
4x 4211399
2x 4211476
6x 6071229
4x 4521921
1x 4255629
4x 6248078
1x 4211758
3x 6163477

3x 6163478
1x 4541978
3x 6227897
1x 4211732
1x 4211735
23x 4568637
7x 4211475
8x 6151349
1x 6052200
1x 4211807
2x 4211526
2x 6183782
1x 4640536
4x 6123815
1x 6185471
4x 6004888
5x 4512360

1x 4515341
2x 6093859
2x 6028813
6x 4211350
6x 6146223
4x 4211398
7x 4211414
2x 6227184
4x 4211470
2x 6066097
2x 4211658
12x 4654580
1x 6044729
15x 6004990
2x 4211644
8x 6258820
2x 4563045
2x 6271817

6x
4650498

2x
6245306

2x
6240204

6x
6240212

2x
6248949

1x
6022032

3x
6135494

1x
6240515

2x
6247783

4x
6245499

4x
6250349

2x
6030333

2x
4666449

10x
4211397

1x
6212077

6x
4211353

2x
4211804

4x
4654577

2x
4538007

1x
4525904

1x
4580510

2x
4211429

1x
6254807

1x
6258156

12x
6168615

4x
6116608

2x
4211639

4x
4507056

2x
6171894

1x
6093054

2x
4211833

1x
6071299

8x
4211356

3x
4211394

10x
4211445

2x
6015347

2x
4211361

8x
4503416

5x
4211395

1x
6195314

1x
6079461

5x
4211425

5x
4211481

2x
4535768

5x
4211406

2x
4211374

1x
4611705

2x
4211402

1x
4211360

4x
4211401

1x
6012451

2x
4211111

30x
4211063

2x
6055629

10x
6146321

3x
6126083

1x
4211129

1x
6071261

4x
6118832

1x
4263176

2x
4211024

2x
6083620

2x
6178912

2x
4211065

1x
4294289

3x
4508553

4x
6074651

2x
4211002

6x
4257526

WIN

GO TO WWW.LEGO.COM/PRODUCTFEEDBACK AND GIVE US YOUR SHORT **FEEDBACK** ABOUT THIS LEGO® SET FOR A CHANCE TO WIN A COOL LEGO PRIZE.

Terms & Conditions apply



LEGO.com/productfeedback

GEWINNE

Erzähle uns auf www.LEGO.com/productfeedback

etwas über die Erfahrungen, die du mit diesem LEGO® Set gemacht hast, und sichere dir die Chance auf einen coolen LEGO Preis!

Es gelten die Teilnahmebedingungen

GAGNE

Rends-toi sur www.LEGO.com/productfeedback

et donne-nous quelques commentaires sur ce produit LEGO® pour avoir une chance de gagner un prix LEGO !

Voir Conditions Générales

GANAN

Visita www.LEGO.com/productfeedback

y envíanos tu opinión acerca de este set LEGO®, ¡Participarás en el sorteo de un premio LEGO!

Términos y Condiciones aplicables

获取奖品

登录 www.LEGO.com/productfeedback

给出关于此乐高®套装的简短反馈，就有机会获得炫酷乐高奖品

《条款及条件》适用

경품 당첨 기회

www.LEGO.com/productfeedback

페이지로 이동하여 이 레고® 세트에 대한 간략한 피드백을 보내 주시고 멋진 레고 경품을 탈 수 있는 기회도 잡으십시오

약관 적용

ЗАПОЛНИ АНКЕТУ И ПОЛУЧИ ПРИЗ

Перейди по ссылке www.LEGO.com/productfeedback

ответь всего на несколько вопросов об этом наборе LEGO®, и у тебя появится шанс выиграть замечательный приз от компании LEGO.

Применяются Условия и правила участия