



- CLASSIC -

Booklet available in English on
Livret disponible en français sur
Folleto disponible en español en



WE'RE MAKING OUR PACKAGING MORE SUSTAINABLE

We're transitioning from single-use plastic to paper-based packaging. As we progress, you may find a mix of paper and plastic in our boxes.

NOUS RENDONS NOS EMBALLAGES PLUS DURABLES

Nous passons des emballages en plastique à usage unique aux emballages à base de papier. Durant la transition, vous pourriez trouver un mélange de papier et de plastique dans nos boîtes.

QUEREMOS HACER MÁS SUSTENTABLES NUESTROS MATERIALES DE EMBALAJE

Estamos cambiando las bolsas de plástico desechables por bolsas con base de papel. Conforme avanzamos en este propósito, puedes encontrar una mezcla de papel y de plástico en nuestras cajas.

LEGO.com/sustainable-packaging

LEGO® VIP

- 1.** SIGN UP
INSCRIVEZ-VOUS
REGÍSTRATE

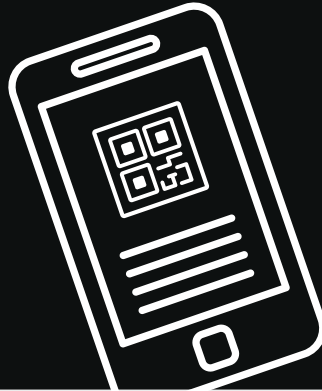

- 2.** EARN POINTS
FOR PURCHASES
GAGNEZ DES POINTS
POUR VOS ACHATS
GANA PUNTOS POR
TUS COMPRAS

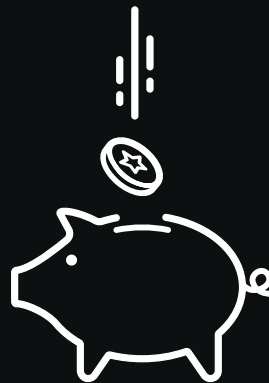

- 3.** REDEEM POINTS FOR REWARDS, EXPERIENCES,
DISCOUNTS & MORE
ÉCHANGEZ DES POINTS CONTRE DES RÉCOMPENSES,
DES EXPÉRIENCES, DES RÉDUCTIONS ET PLUS ENCORE
CANJEA PUNTOS POR RECOMPENSAS, EXPERIENCIAS,
DESCUENTOS Y MUCHO MÁS

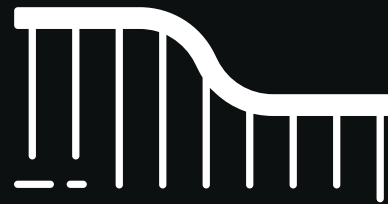
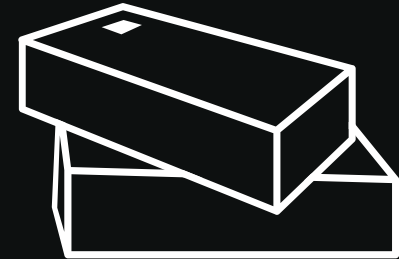
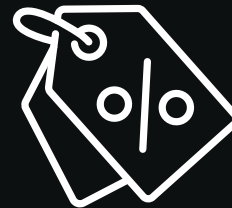

LEGOLAND®



"ONE DAY I'LL BUILD A LAND ROVER." ONE DAY IS NOW.

A trusted, trail-blazing traveler on off-road explorations, a symbol of rugged strength and a nostalgic collectible. Originally built in post-World War II Britain as a sturdy and reliable farm utility vehicle, the versatile Land Rover has become one of the most recognized and coveted vehicles

in the world. For 75 years, Land Rover models have evolved with innovative technology and design. Still, the appeal of the original hands-on construction and mechanics is felt in the details of every new generation; most of all in the Land Rover Defender series.

« UN JOUR, JE CONSTRUIRAI UNE LAND ROVER. » CE JOUR, C'EST AUJOURD'HUI.

Un véhicule de confiance, pionnier des explorations tout-terrain, un symbole de robustesse et un objet de collection nostalgique. Construite à l'origine dans la Grande-Bretagne d'après la Seconde Guerre mondiale comme un véhicule utilitaire agricole robuste et fiable, la polyvalente Land Rover est devenue l'un des véhicules les plus reconnus et

les plus convoités au monde. Depuis 75 ans, les modèles de Land Rover ont évolué grâce à une technologie et à une conception innovantes. Pourtant, l'attrait de la construction et de la mécanique d'origine se ressent dans les détails de chaque nouvelle génération, surtout dans la série Land Rover Defender.

"UN DÍA CONSTRUIRÉ UN LAND ROVER". ESE DÍA YA LLEGÓ.

El viajero más confiable, todo un pionero de las exploraciones en carreteras y donde no hay estas, un símbolo de fuerza y robustez y un objeto de colección que evoca nostalgia. Creado originalmente en la Gran Bretaña de la posguerra luego de la Segunda Guerra Mundial como un resistente vehículo utilitario para el trabajo del campo, el versátil Land Rover se ha convertido en uno de los vehículos

más reconocidos y deseados del mundo. A lo largo de 75 años, los modelos del Land Rover han evolucionado con nuevas tecnologías y diseños de vanguardia. No obstante, el atractivo de su construcción y mecánica artesanales aún puede percibirse en los detalles de cada nueva generación, particularmente en los vehículos de la serie Land Rover Defender.



75 YEARS OF LAND ROVER DEFENDER

1948

Durability and capability in design and performance have dominated Land Rover models through the decades. Follow in the path of some of the most legendary Land Rover models.

1948 THE LAND ROVER SERIES I

The affectionately nicknamed 'Farmer's Friend' debuts in post-war Britain

LA LAND ROVER SÉRIE I

Affectueusement surnommée « l'amie du fermier », elle fait ses débuts dans la Grande-Bretagne d'après-guerre.

LAND ROVER SERIES I

Apodado cariñosamente *farmer's friend* ("amigo del granjero"), el vehículo debuta en la Gran Bretaña de la posguerra.



50s

1958 THE LAND ROVER SERIES II

The updated model features a new .59 US gallon (2.25-liter) gasoline engine

LA LAND ROVER SÉRIE II

Le modèle actualisé est doté d'un nouveau moteur à essence de 2,25 litres.

LAND ROVER SERIES II

Este modelo actualizado incorpora un nuevo motor a gasolina de 2,25 l.



2020 THE NEW LAND ROVER DEFENDER

A new generation of Defender celebrates the legacy of a legend

LA NOUVELLE LAND ROVER DEFENDER

Une nouvelle génération de Defender célèbre l'héritage d'une légende.

EL NUEVO LAND ROVER DEFENDER

El Defender de la nueva generación celebra el legado de una leyenda.



2015

A trio of end-of-line Defenders marks a temporary farewell to the Land Rover

10s



2015

Un trio de Defenders en fin de série marque un adieu temporaire à la Land Rover.

2015

Un trio de modelos Defender de fin de línea marca su despedida temporal del catálogo de la marca Land Rover.

20s

75 ANS DE LAND ROVER DEFENDER

La durabilité et le potentiel de la conception et des performances ont dominé les modèles de Land Rover au fil des décennies. Retracez le sillon de certains des modèles de Land Rover les plus légendaires.

1969

In the Series II visual update, the headlights are moved to the front wings

Dans le cadre de la mise à jour visuelle de la série II, les phares sont déplacés vers les ailes avant.

En la actualización estética del Series II, los faros se trasladan a las salpicaderas frontales.

60's



70's

75 AÑOS DEL LAND ROVER DEFENDER

La durabilidad y el diseño orientado a la capacidad y el desempeño son la esencia de los modelos del Land Rover lanzados a lo largo de muchas décadas. Síguelos la pista a algunos de los modelos del Land Rover más legendarios de todos los tiempos.

1971

THE LAND ROVER SERIES III

The third generation of the iconic Land Rover is launched

LA LAND ROVER SÉRIE III

La troisième génération de l'emblématique Land Rover est lancée.

LAND ROVER SERIES III

Se lanza la tercera generación del icónico Land Rover.



1976

The 1,000,000th Land Rover is built

La millionième Land Rover est construite.

Se construye el Land Rover número 1.000.000.

2007

Hood bulge added to incorporate new Ford Puma engine

1990

DEFENDER

The original 'Landie' is relaunched under a new name

00's



90's



80's

2007

Le capot est bombé pour intégrer le nouveau moteur Ford Puma.

1990

DEFENDER

La « Landie » originale est relancée sous un nouveau nom.

1983

Land Rover goes coil-sprung with the launch of the One-Ten and Ninety

La Land Rover adopte la suspension hélicoïdale avec le lancement des modèles One-Ten et Ninety.

El lanzamiento del One-Ten y el Ninety marca la incorporación de los muelles helicoidales en el Land Rover.

2007

Se añade una prominencia al cofre para dar cabida al nuevo motor Ford Puma.

1990

DEFENDER

Se relanza el Landie original con un nuevo nombre.

23

LEGO® LAND ROVER CLASSIC DEFENDER 90

A buildable tribute to Land Rover classic Defender 90 models released 1983–2016

LEGO® LAND ROVER DEFENDER 90 CLASSIQUE

Un hommage aux modèles de Land Rover Defender 90 classiques sortis entre 1983 et 2016 à construire.

LAND ROVER DEFENDER 90 CLÁSICO LEGO®

Un homenaje construible a los modelos Land Rover Defender 90 clásicos lanzados entre 1983 y 2016.

A WORD FROM THE DESIGNER

"We're so excited to present this set in collaboration with Land Rover. Each Land Rover Defender has its own story, its own personality and inspires a sense of adventure everyone can relate to. It's the ultimate utility vehicle that will take you anywhere, from deserts and mountains to urban highways and country byways. This model represents an amalgamation of Land Rover classic Defender 90 models released between 1983 to 2016, with authentic accessories and equipment. To capture the versatility of the Defender, the model is designed with multiple options for both exterior and interior features, just like when you order the real-life version. So, buckle up and enjoy the ride. Welcome to the LEGO® Land Rover family!"

UN MOT DU CONCEPTEUR

« Nous sommes ravis de présenter cet ensemble en collaboration avec Land Rover. Chaque Land Rover Defender a une histoire et une personnalité qui lui sont propres et inspire un sens de l'aventure auquel chacun est sensible. C'est le véhicule utilitaire par excellence qui vous accompagne partout, des déserts aux montagnes en passant par les autoroutes urbaines et les chemins de campagne. Ce modèle représente un amalgame des modèles de Land Rover Defender 90 classiques sortis entre 1983 et 2016, avec des accessoires et des équipements authentiques. Afin de refléter la polyvalence de la Defender, le modèle est conçu avec de multiples options pour les caractéristiques extérieures et intérieures, tout comme lorsque vous commandez la version réelle. Attachez votre ceinture et profitez du voyage. Bienvenue dans la famille LEGO® Land Rover ! »

EN PALABRAS DEL DISEÑADOR

"Estamos muy emocionados de presentar este set en colaboración con Land Rover. Cada Land Rover Defender tiene su propia historia y una personalidad única, y es capaz de inspirar una sensación de aventura con la que todos podemos identificarnos. Sin duda, hablamos del vehículo utilitario supremo, que puede llevarte a cualquier lugar, desde desiertos y montañas hasta autopistas urbanas y caminos rurales. Este modelo representa una amalgama de los modelos Land Rover Defender 90 clásicos lanzados entre 1983 y 2016, con accesorios y equipo de gran autenticidad. Con el fin de capturar la versatilidad del Defender, el modelo se diseñó con múltiples opciones para las características exteriores e interiores, tal como la versión de la vida real. Solo falta que subas, te abroches el cinturón y disfrutes del viaje. ¡Bienvenido a la familia LEGO® Land Rover!"

KURT KRISTIANSEN
LEGO® DESIGN MASTER
*Designer of the 10317 LEGO Land Rover
classic Defender 90*

KURT KRISTIANSEN
MAÎTRE DE LA CONCEPTION LEGO®
*Concepteur de l'ensemble 10317 LEGO Land Rover
Defender 90 classique*

KURT KRISTIANSEN
MAESTRO DE DISEÑO DE LEGO®
*Diseñador del modelo LEGO del Land Rover
Defender 90 clásico (10317)*

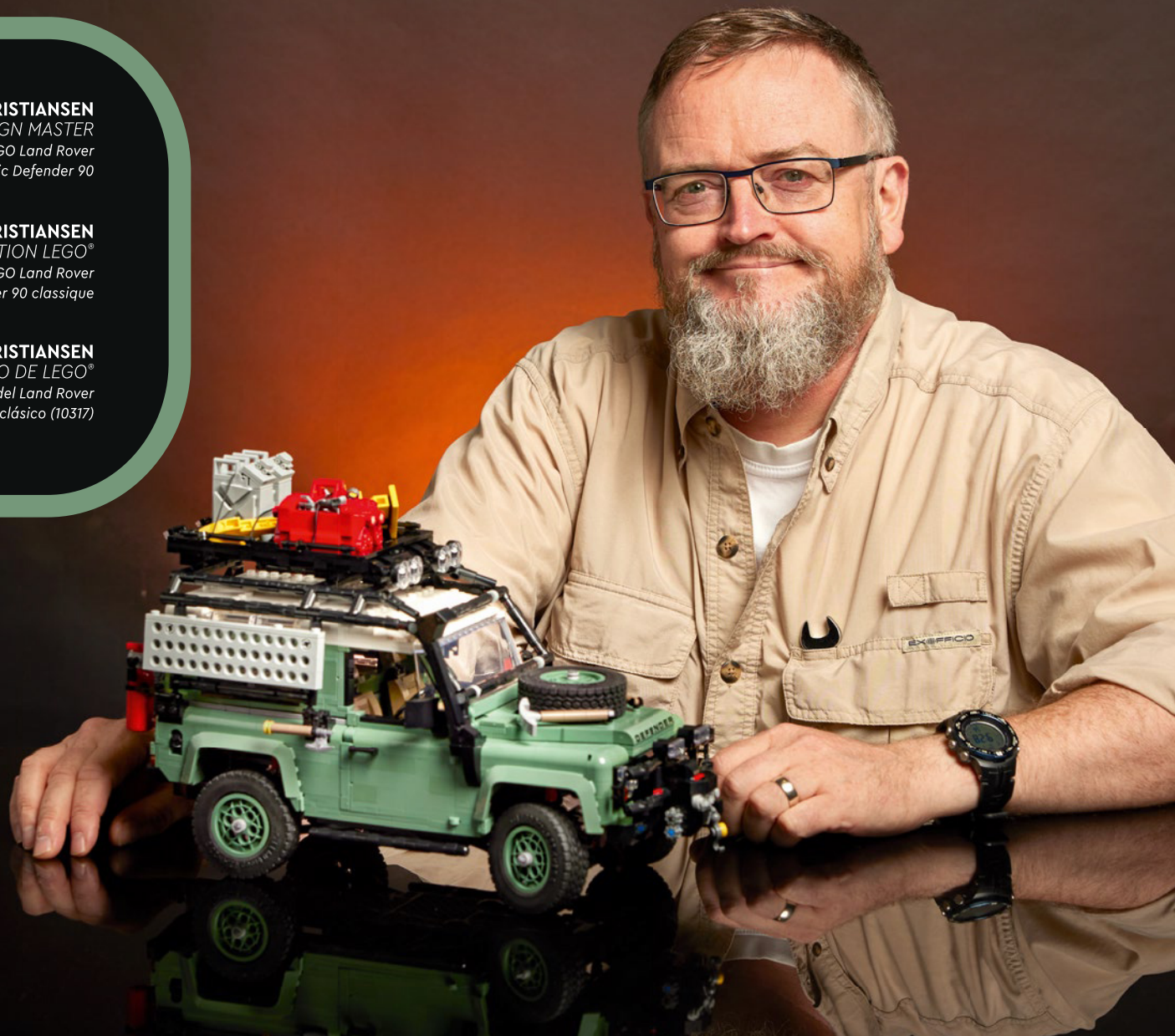

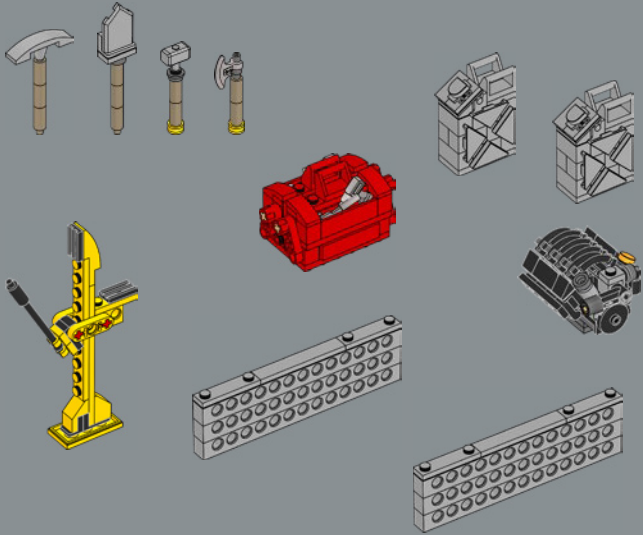
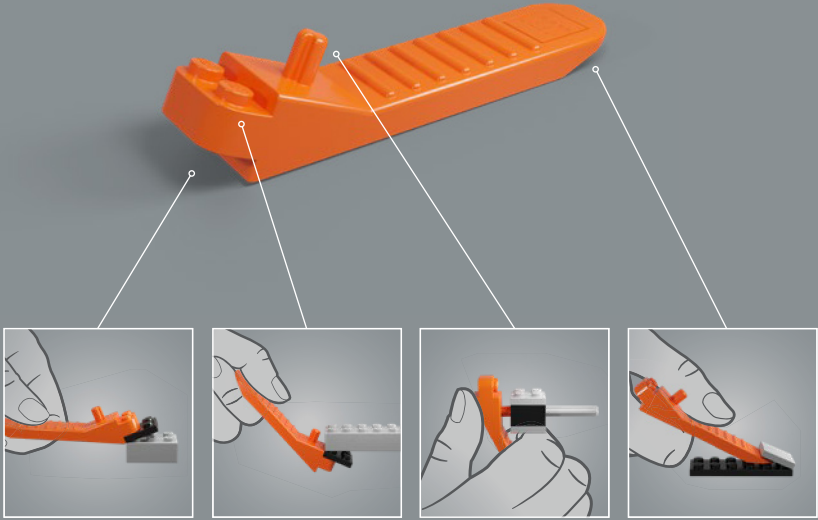

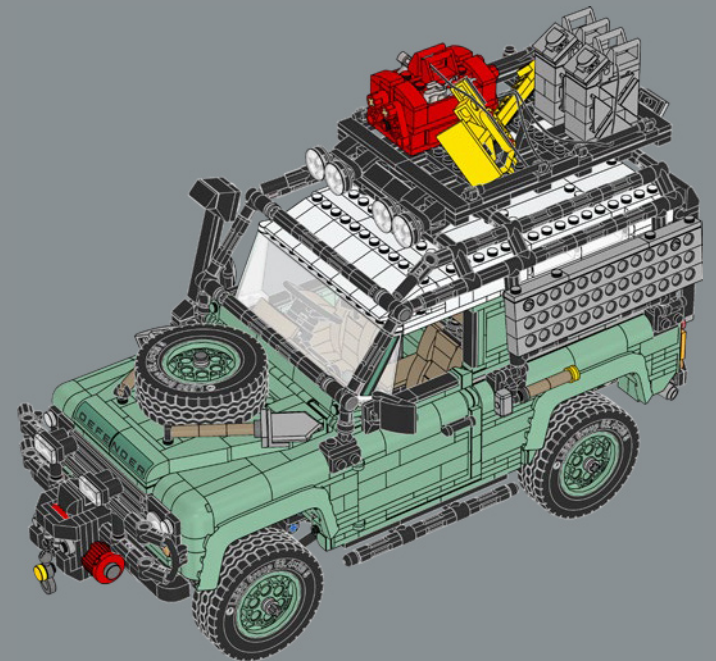
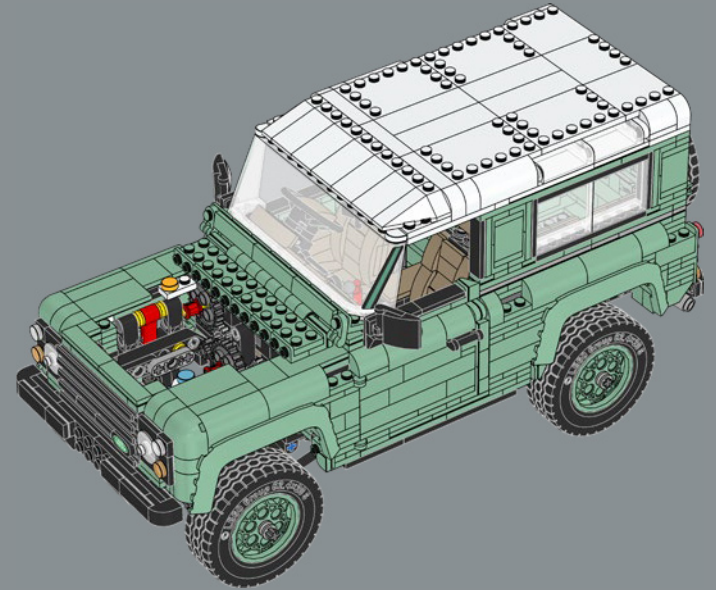
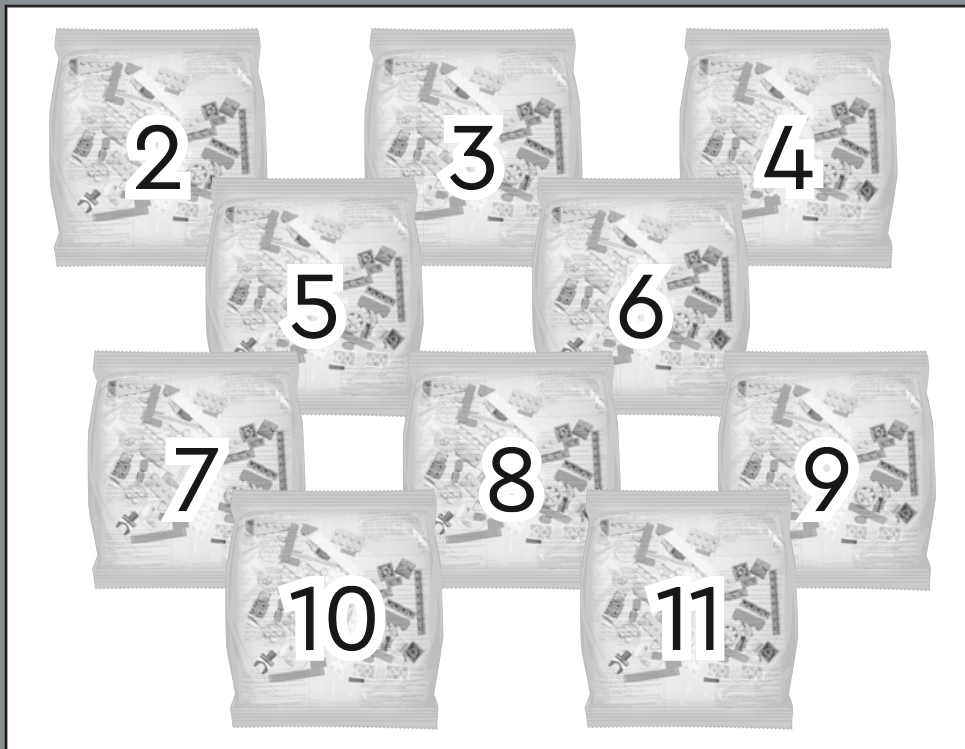

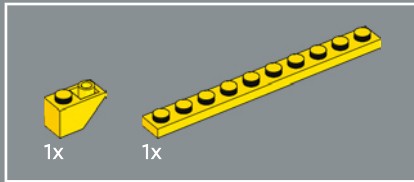
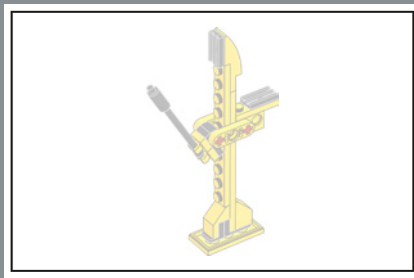

1

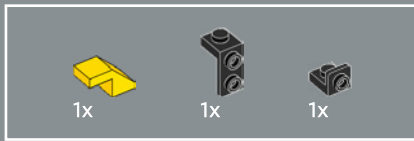
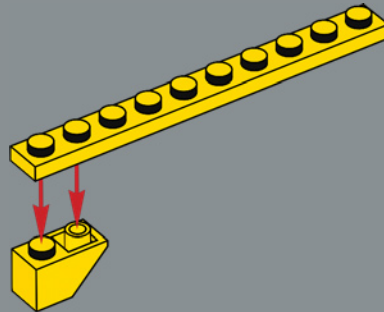

2

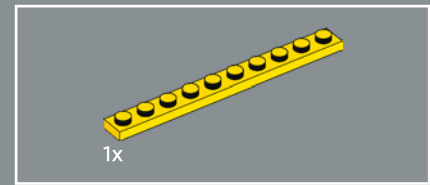
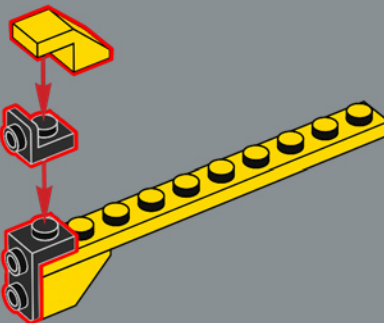

3

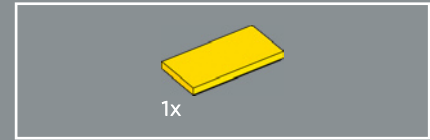
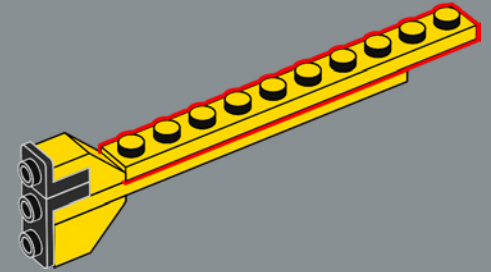

4

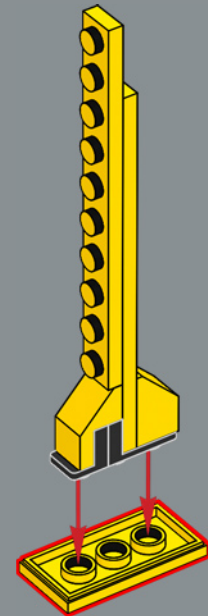

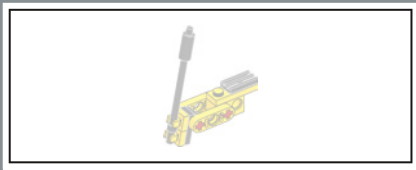

5



6



7

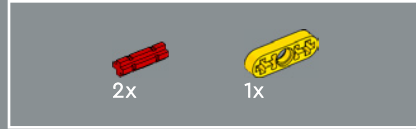
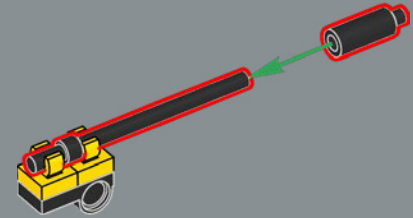

8

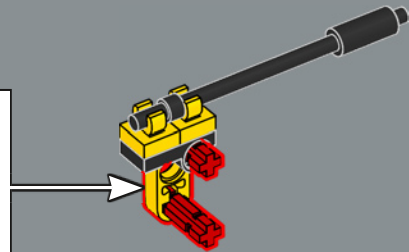
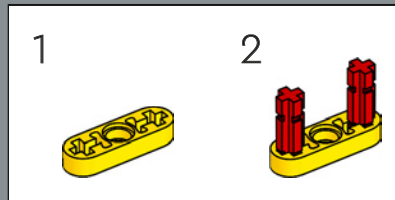

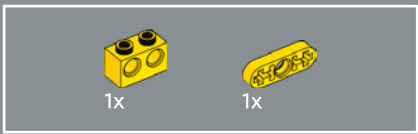

9

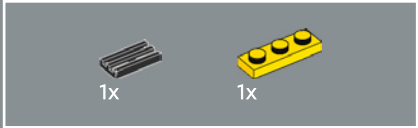
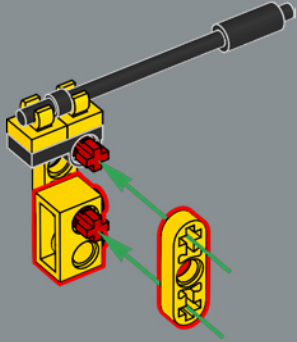

10

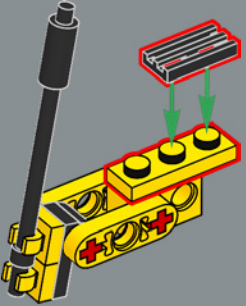

11

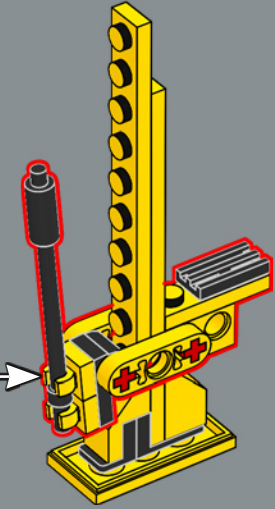

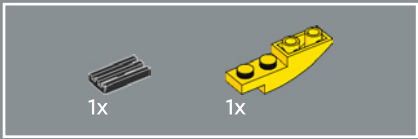

12

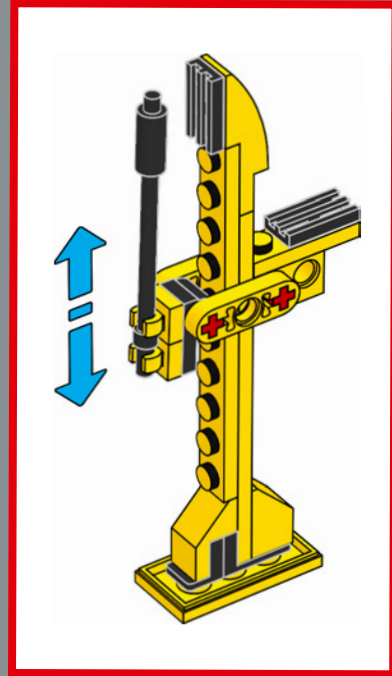
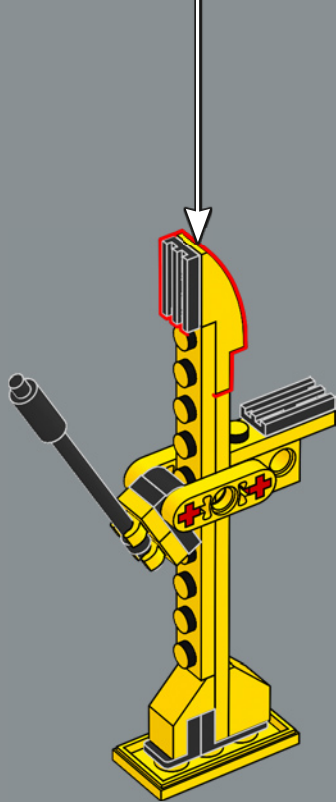
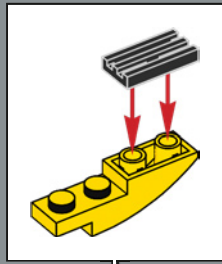

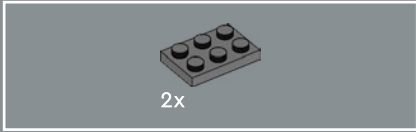
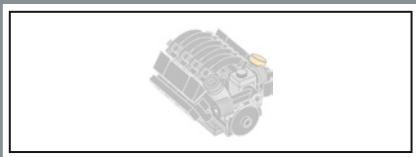

1

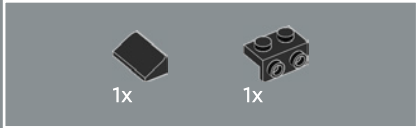
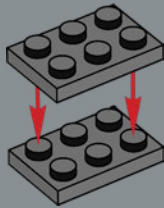

2

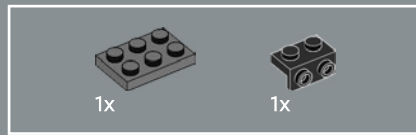
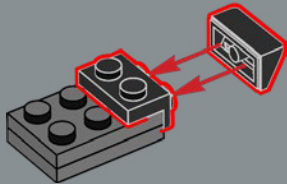

3

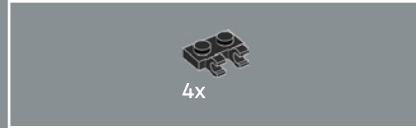
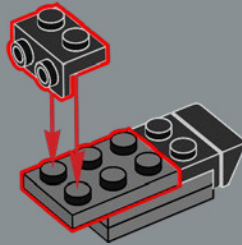

4

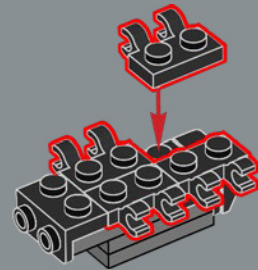

5

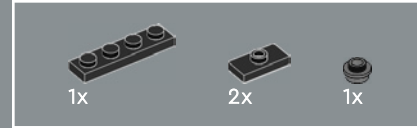
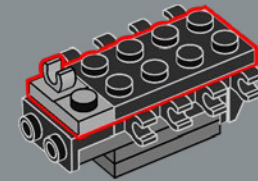

6

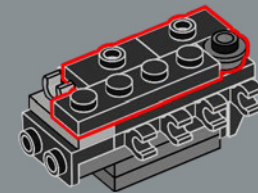



7

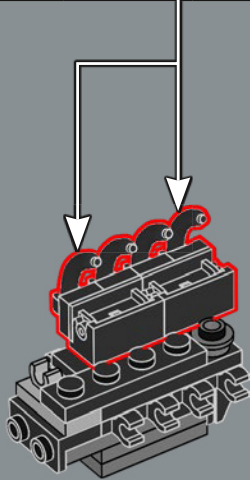
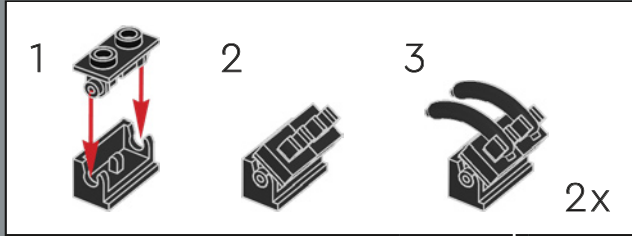

8

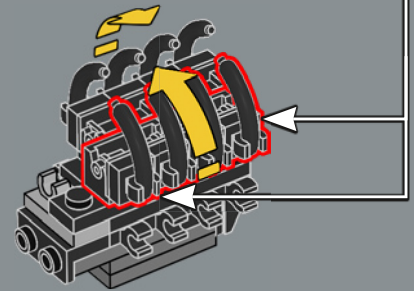
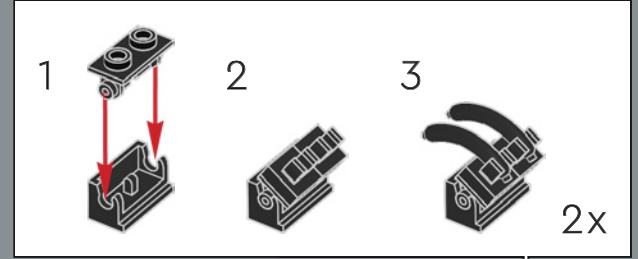

9

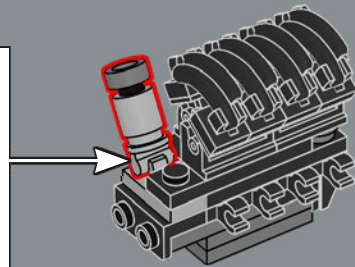
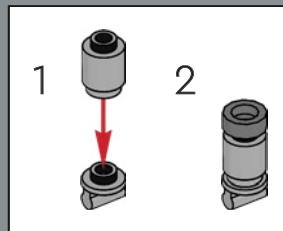



10

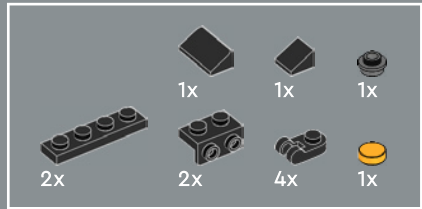
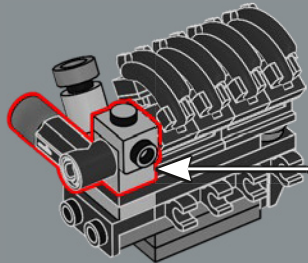
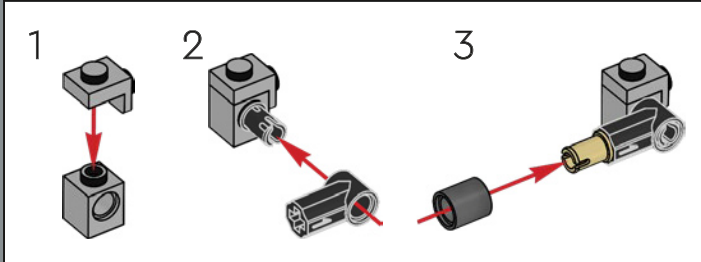

12

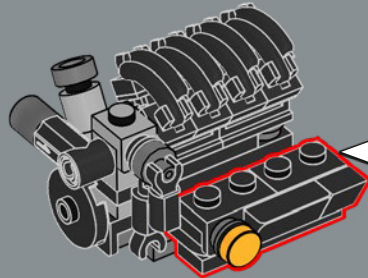
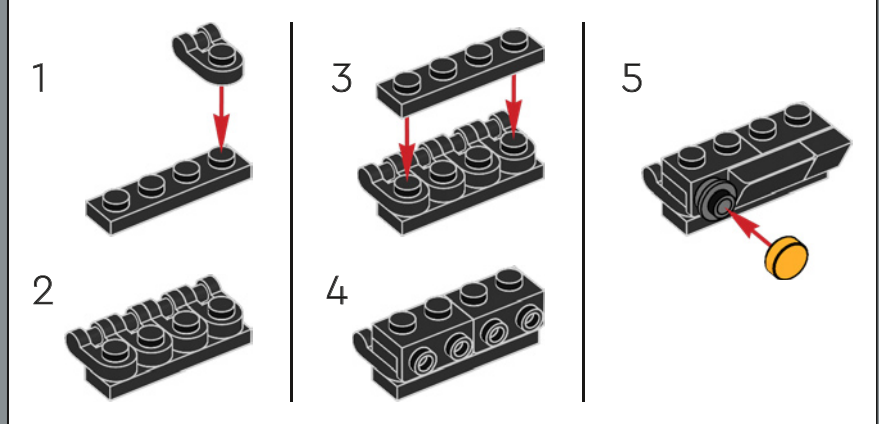

11

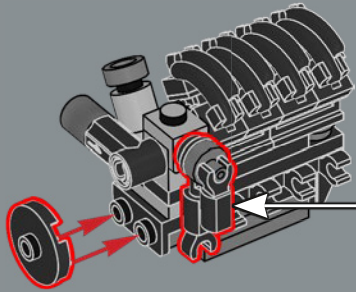
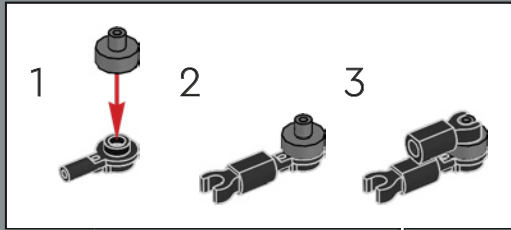

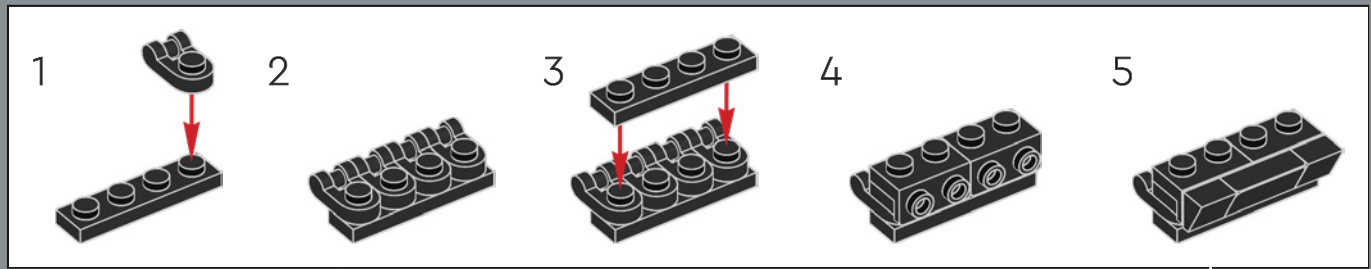
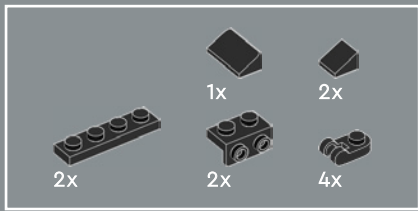

13

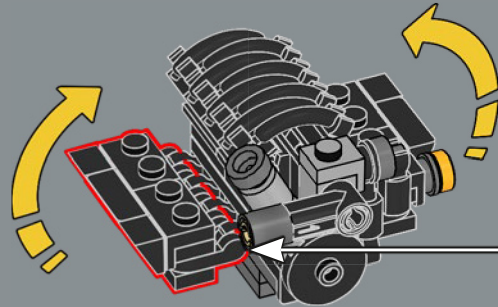

14

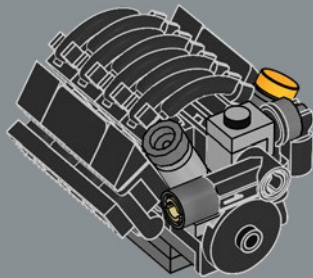

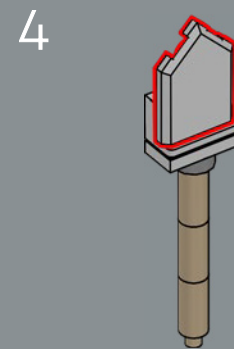
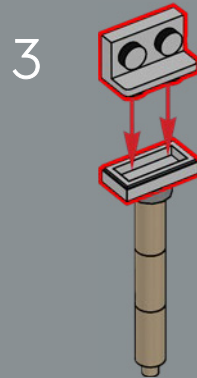
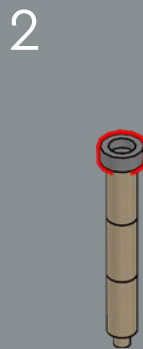
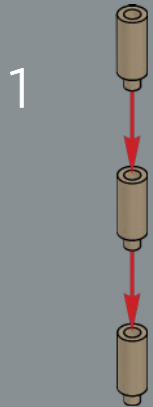
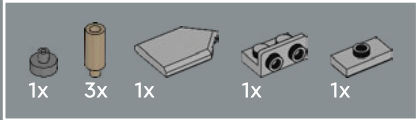
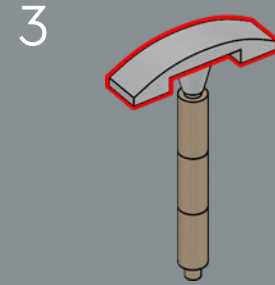
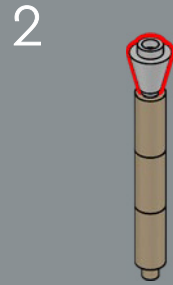
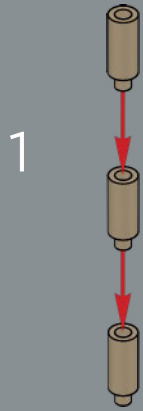
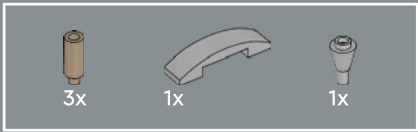

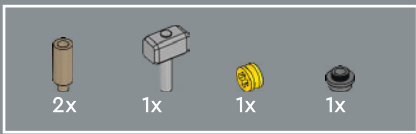

1



2



3



1



2

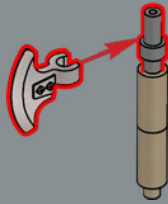

3



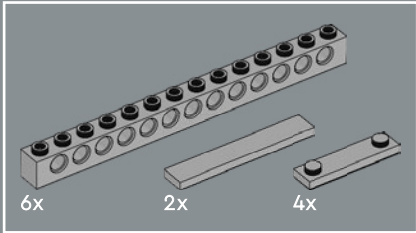
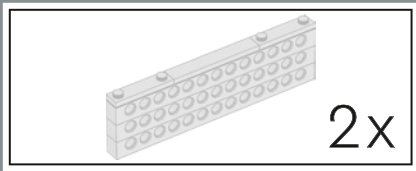

1

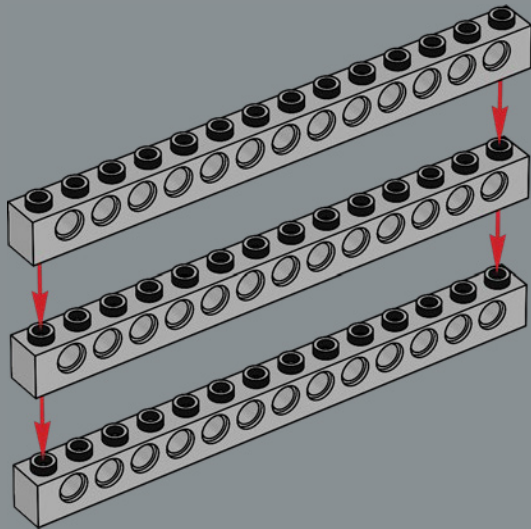

2

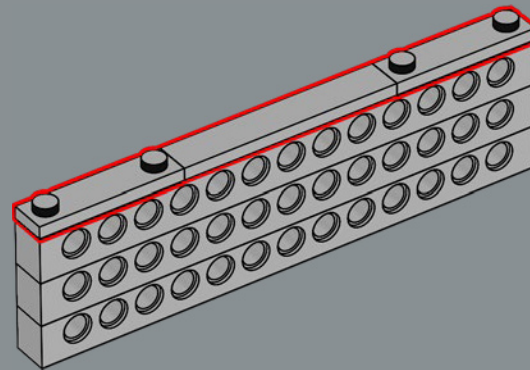

2x

Did you know the sand plates were originally designed to build runways on soft or boggy ground?

Saviez-vous que les plaques de désensablage ont été conçues à l'origine pour construire des pistes d'atterrissage sur des sols mous ou marécageux ?

¿Sabías que las placas para arena se diseñaron originalmente para construir pasos sobre terreno blando o fangoso?

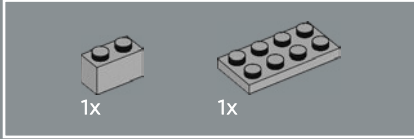
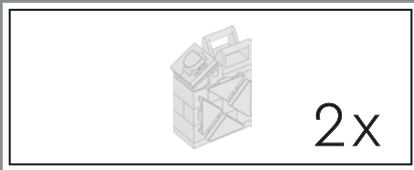

1

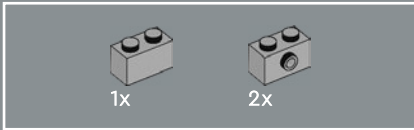
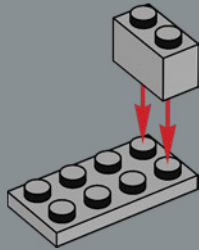

2

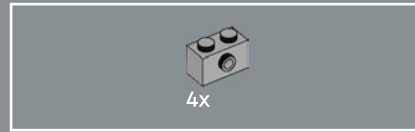
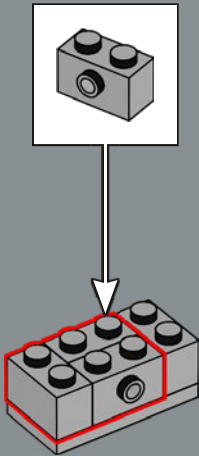

3

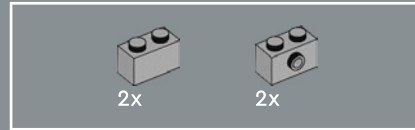
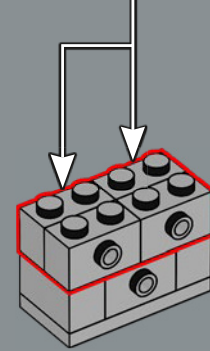
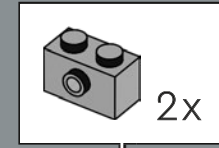

4

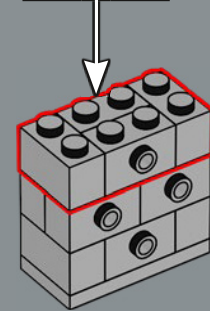
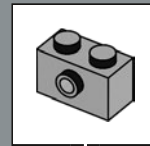

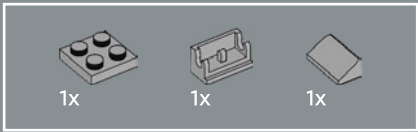

5

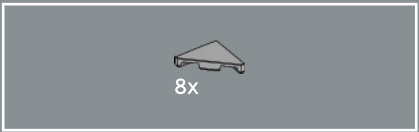
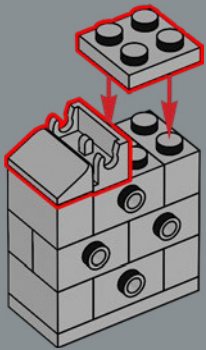

6

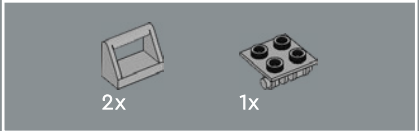
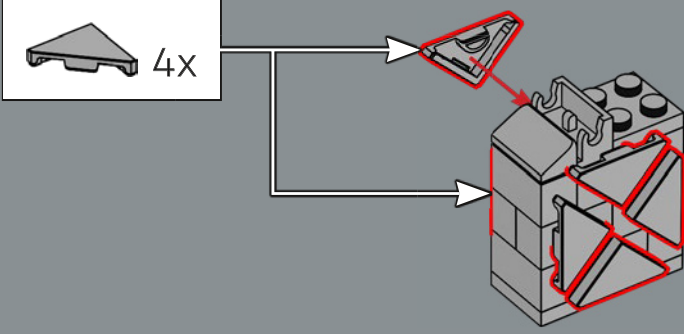

7

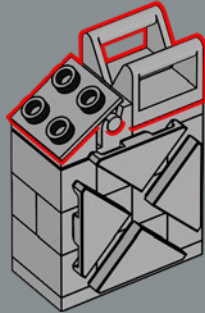

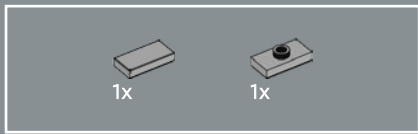

8

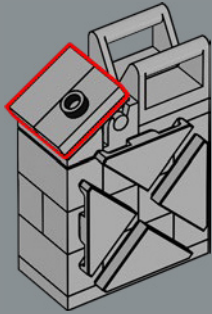

9

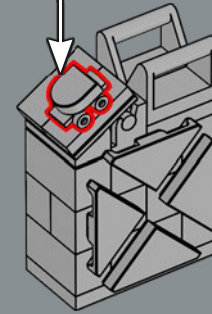
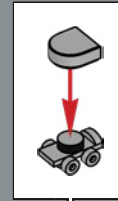

2x

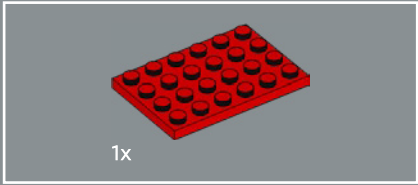
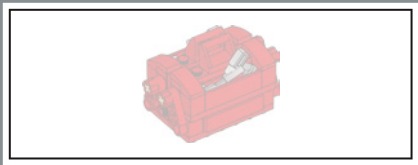

1

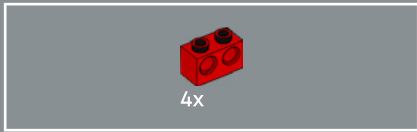
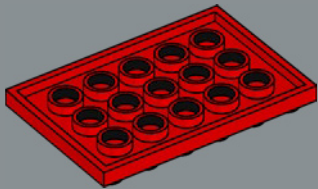

2

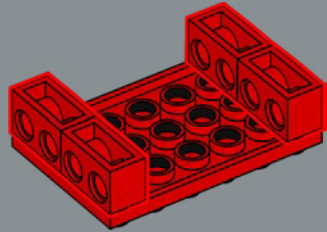

3

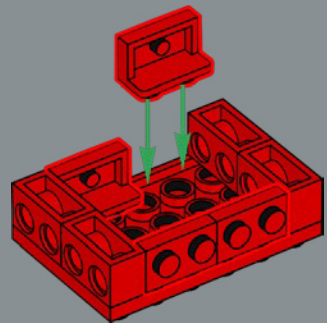

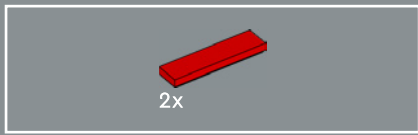

4

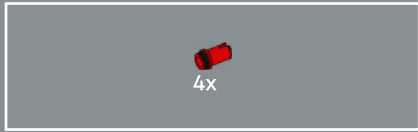
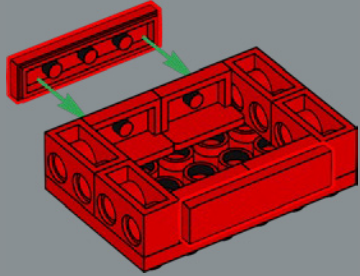

5

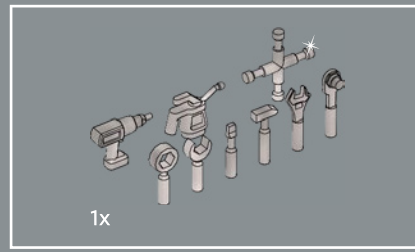
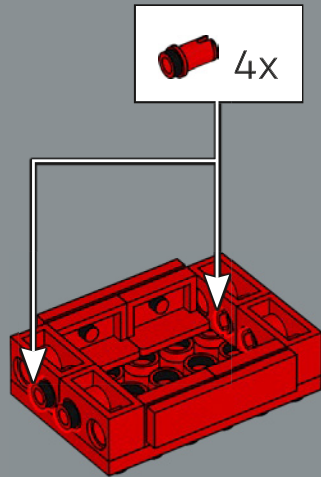

6

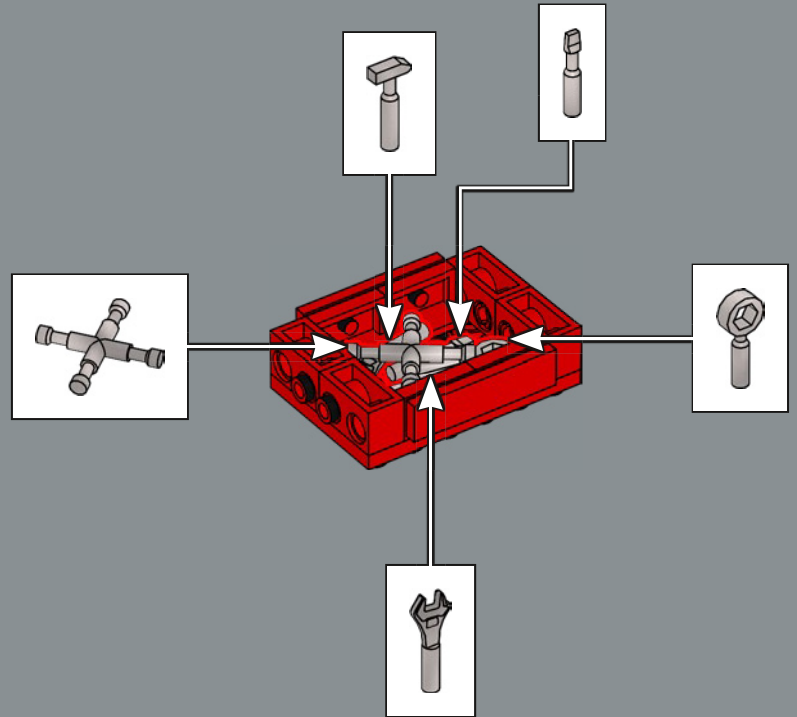

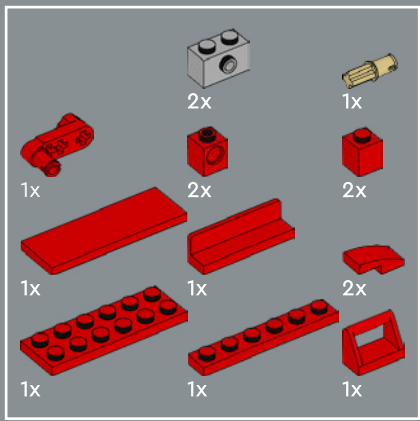

7

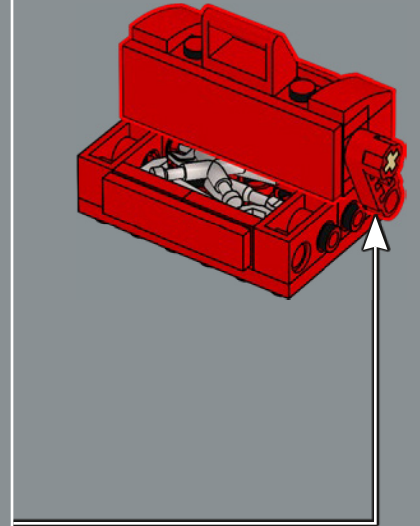
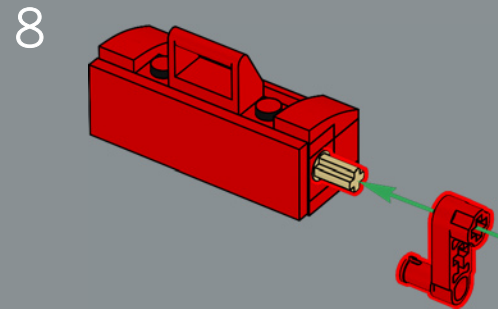
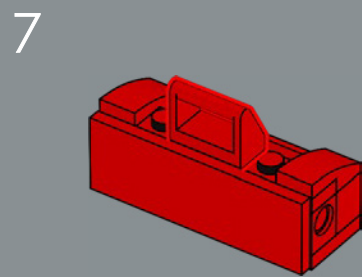
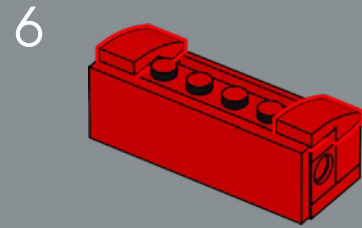
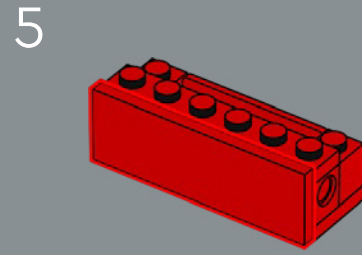
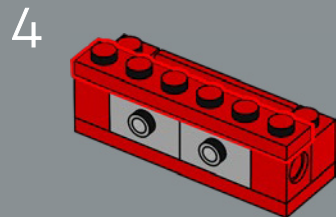
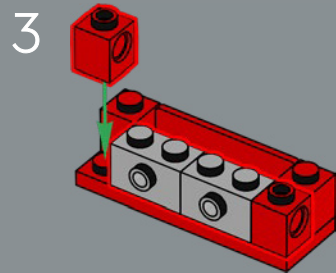
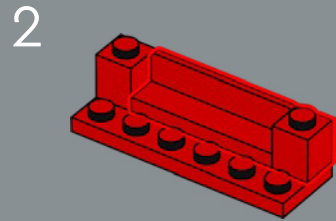
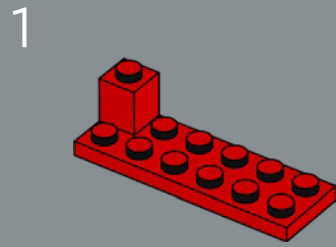

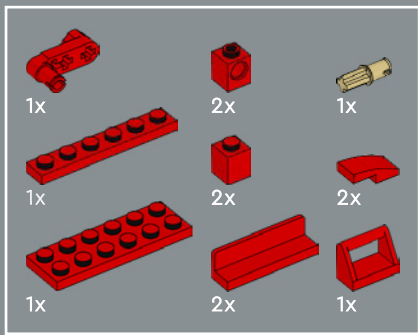

8

1

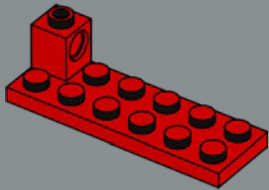

2

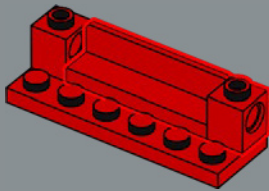

3

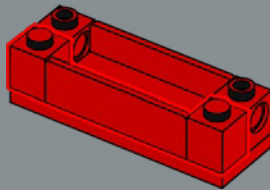

4

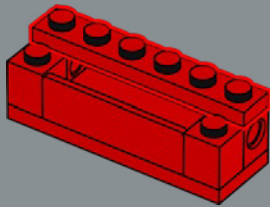

5

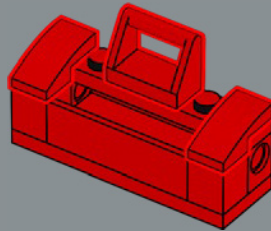

6

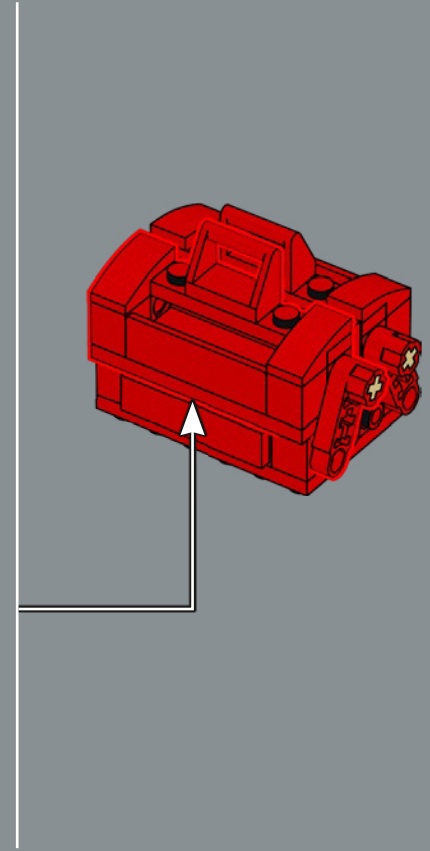
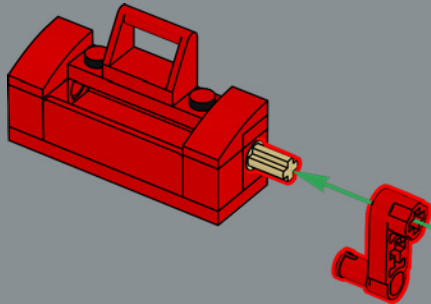

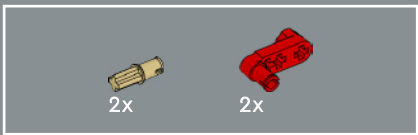

9

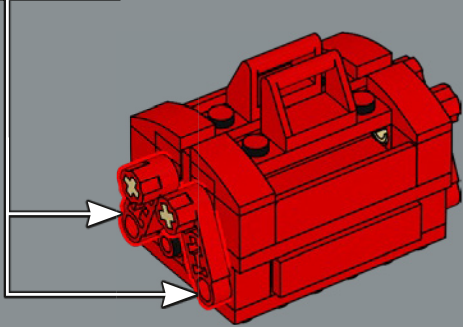
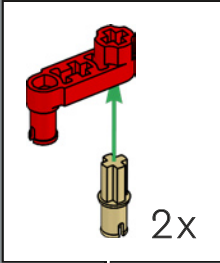

10

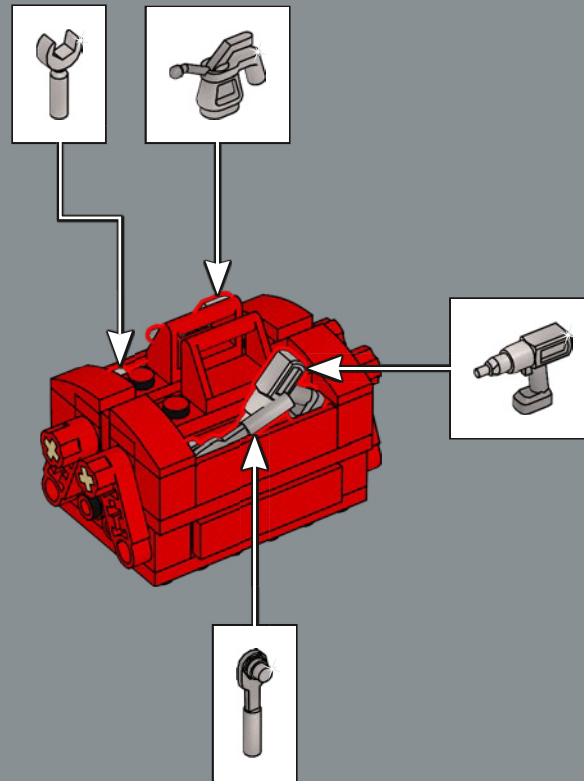

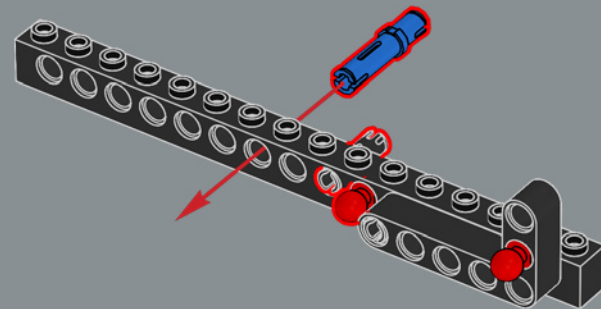
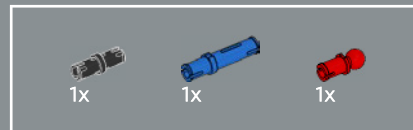
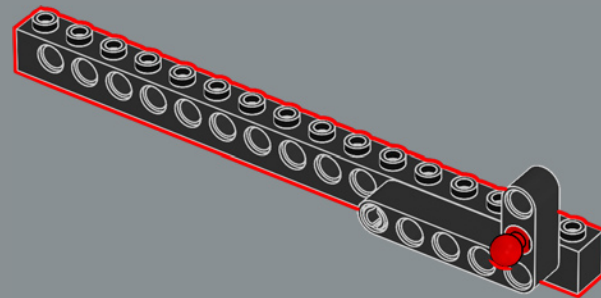
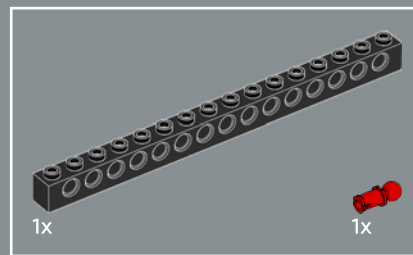
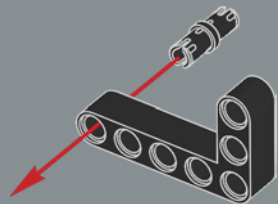
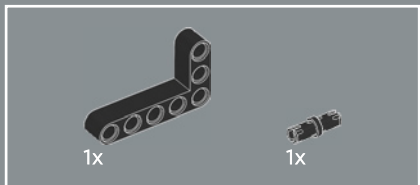
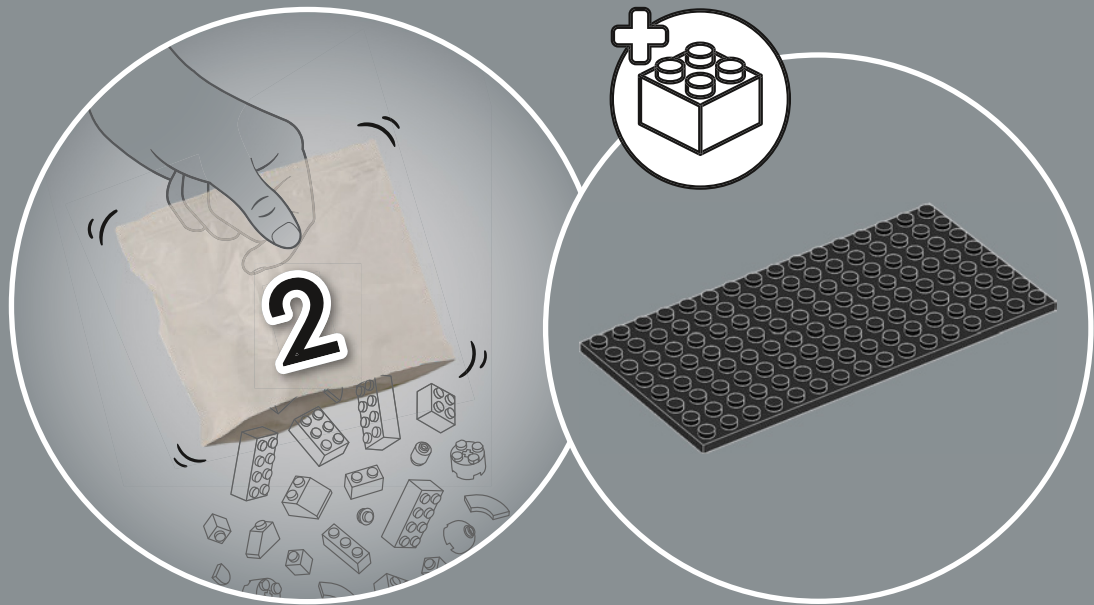

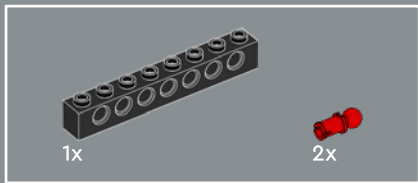

4

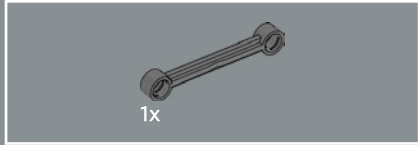
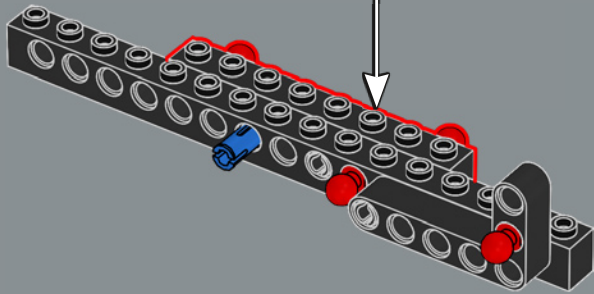
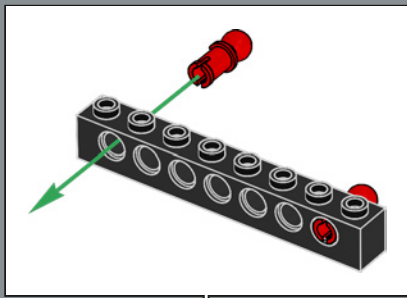

5

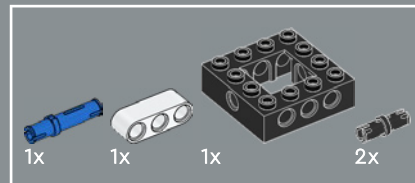
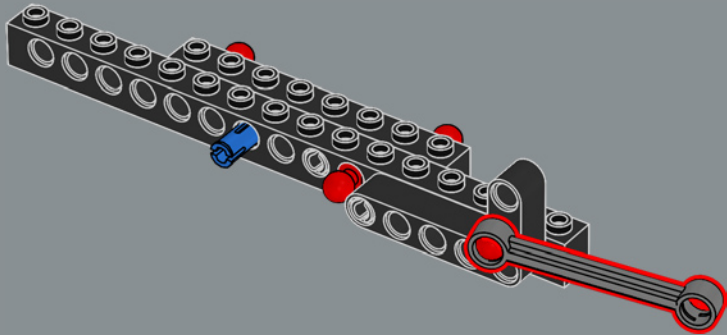

6

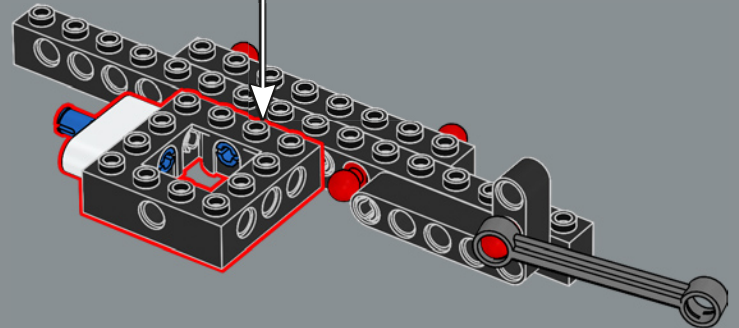
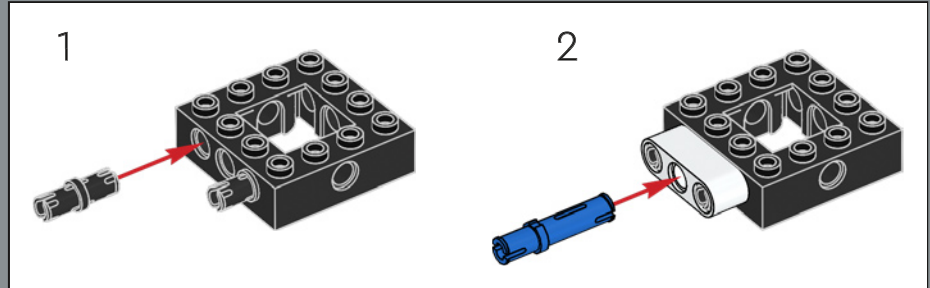

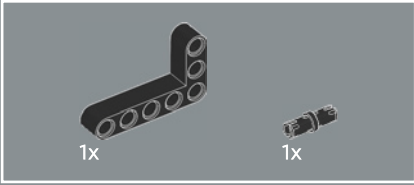
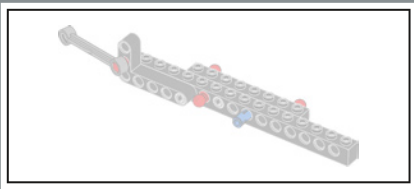

7

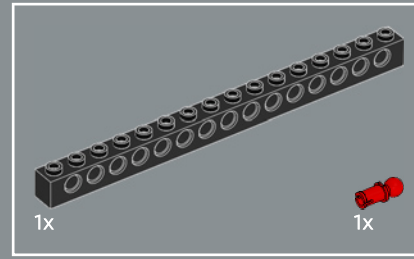
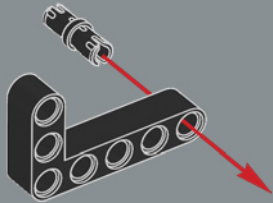

8

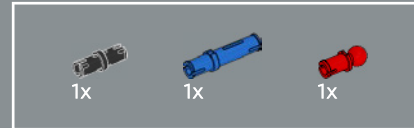
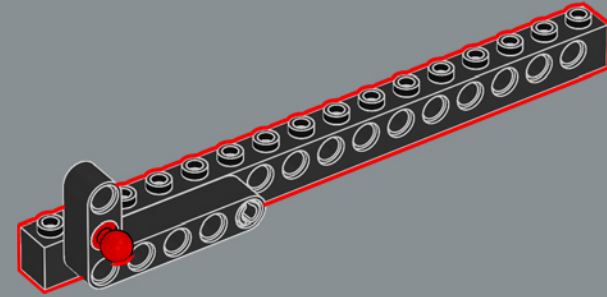

9

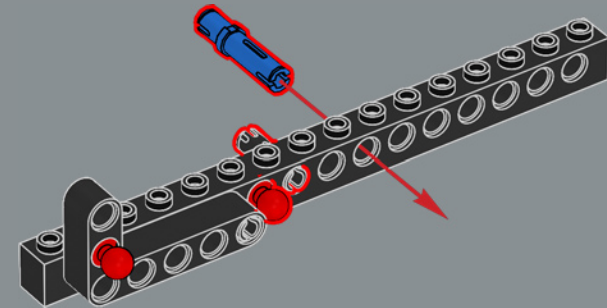

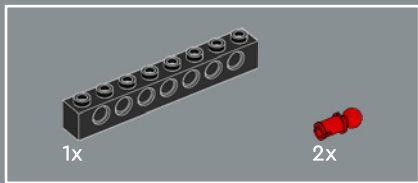

10

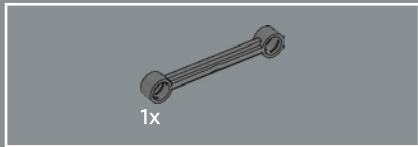
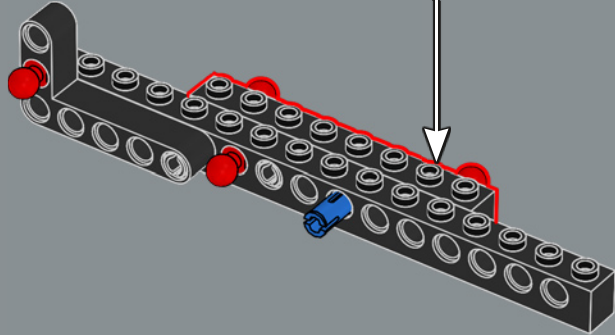
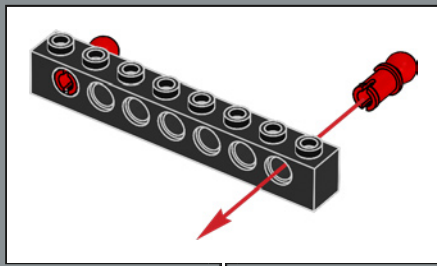

11

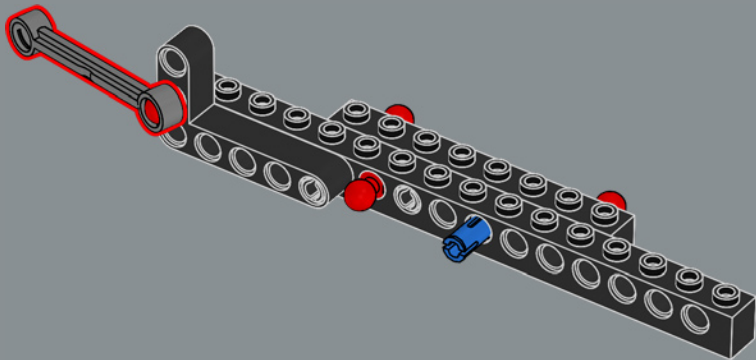

12

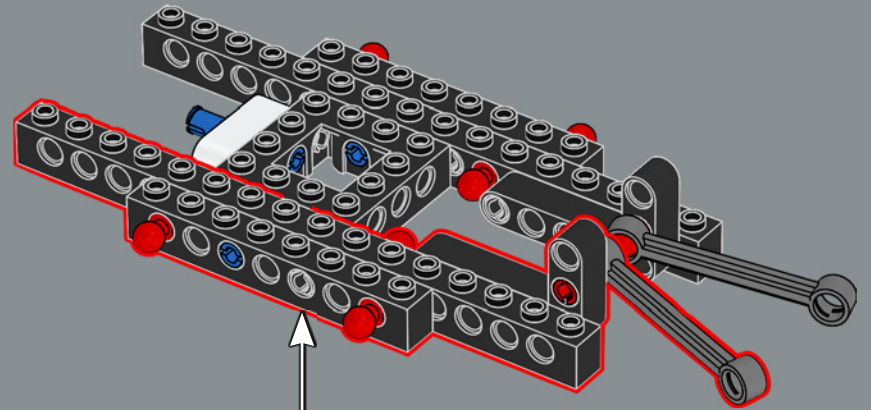

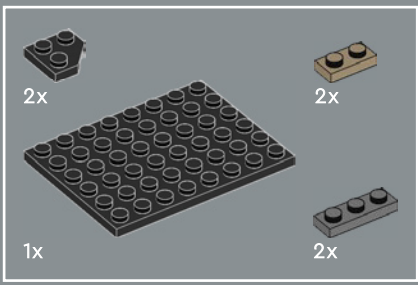

13

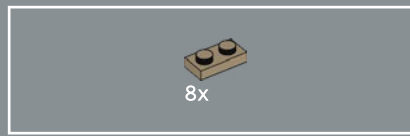
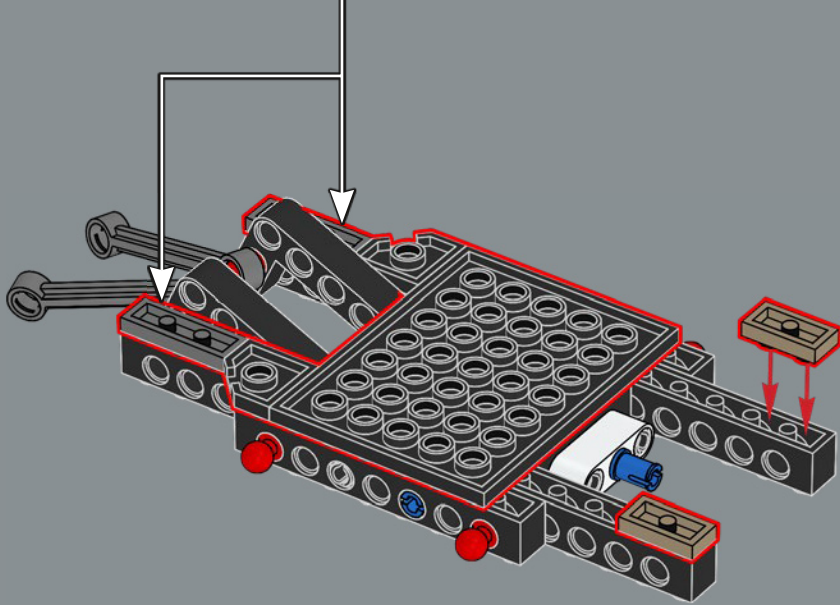
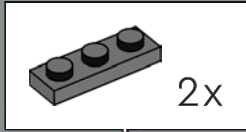

14

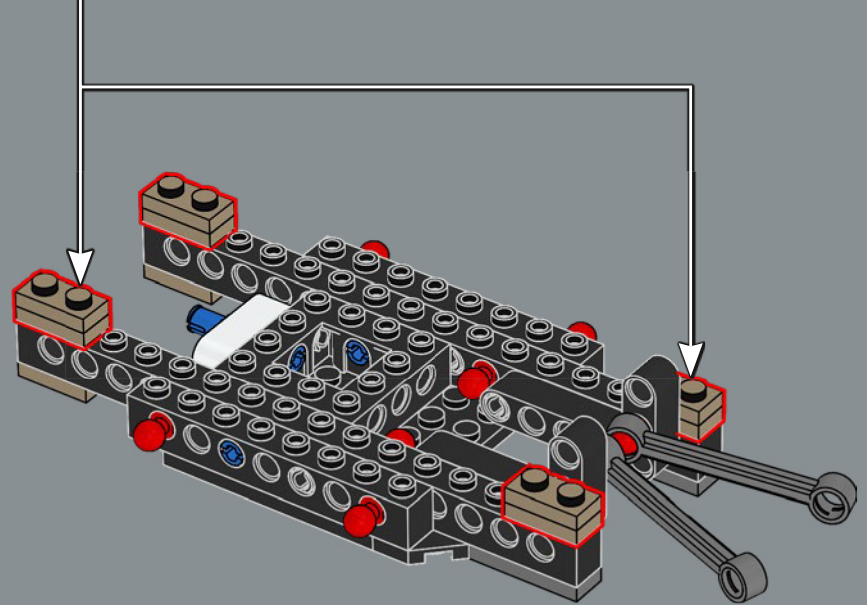
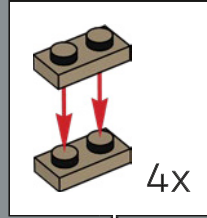

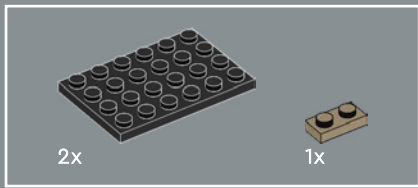

15

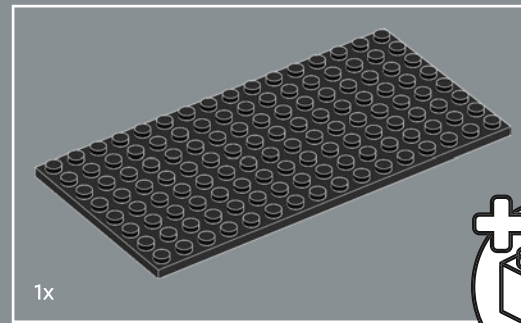
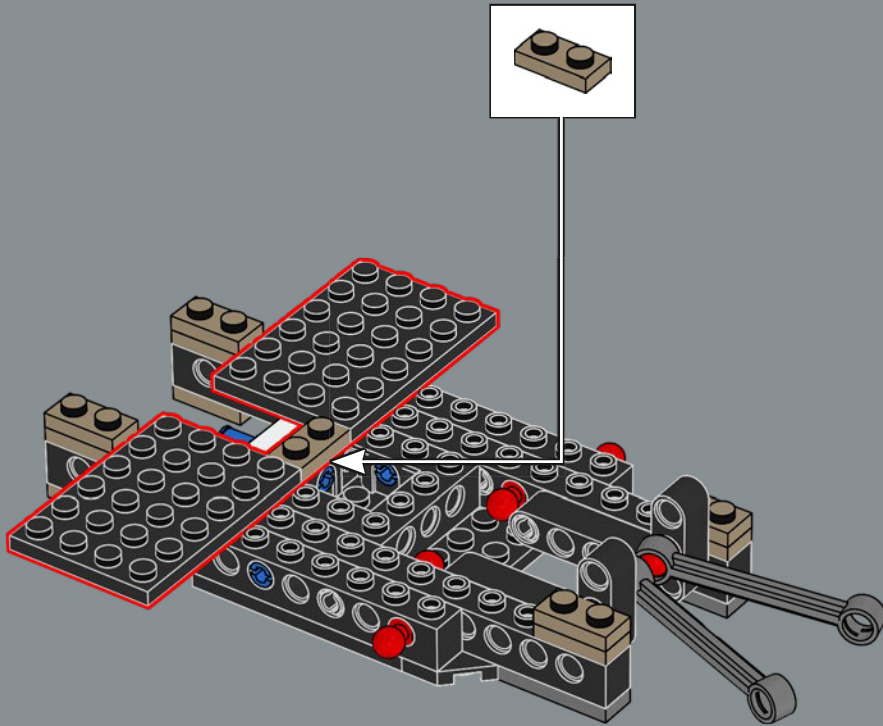

16

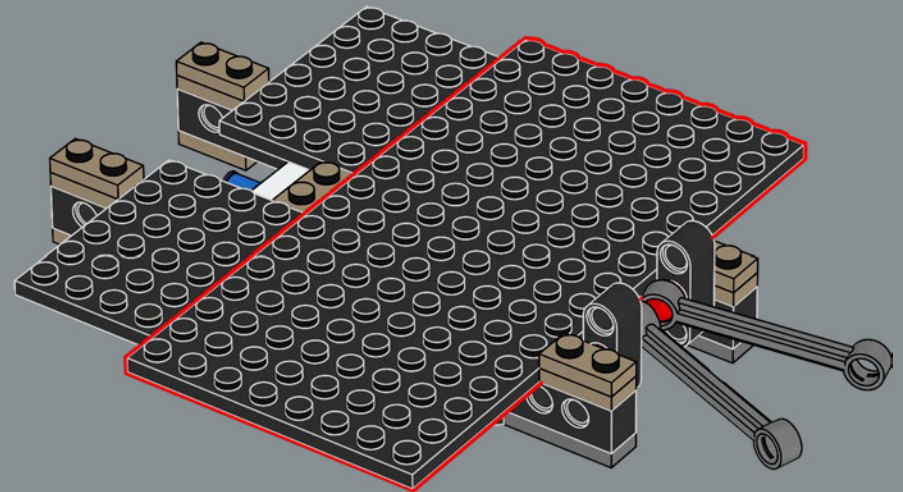
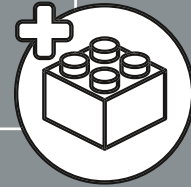

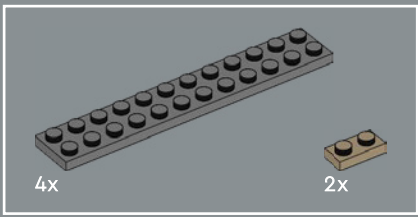

17

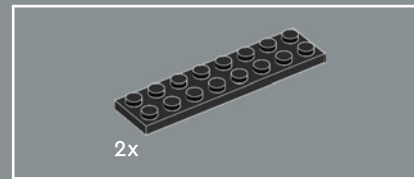
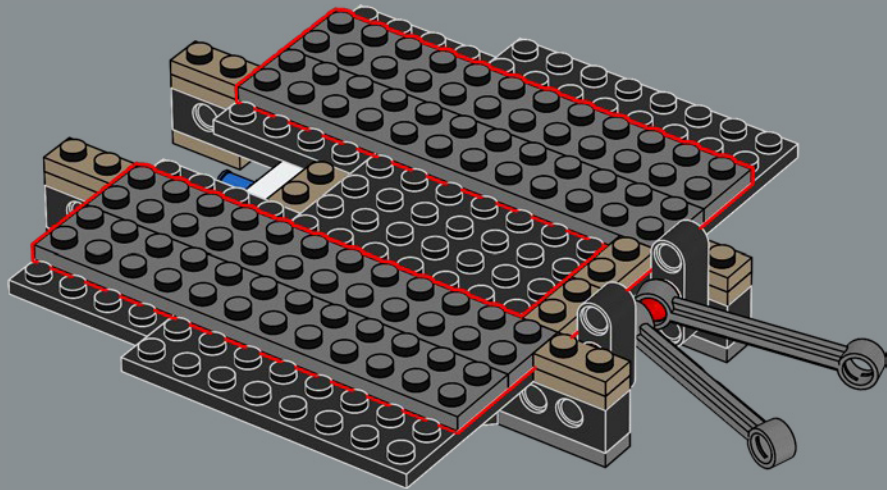

18

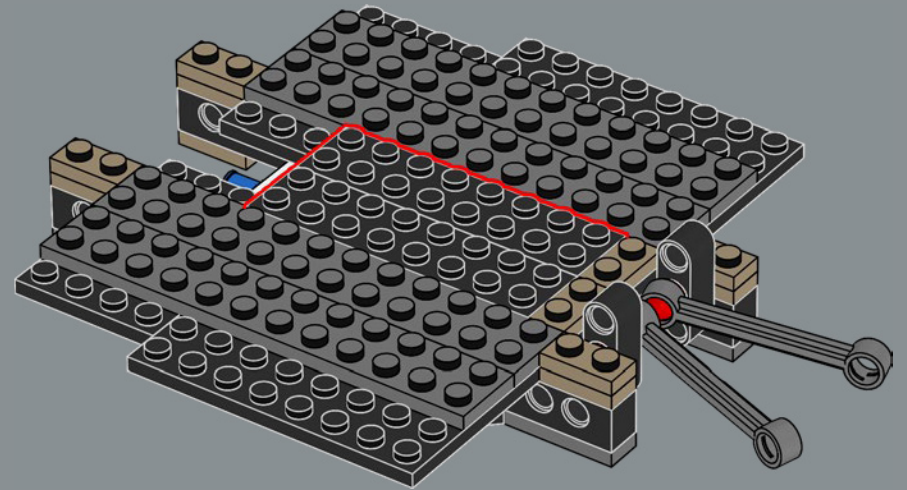

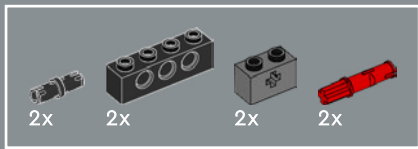

19

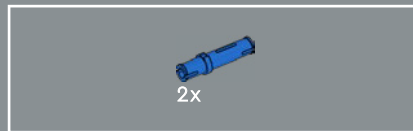
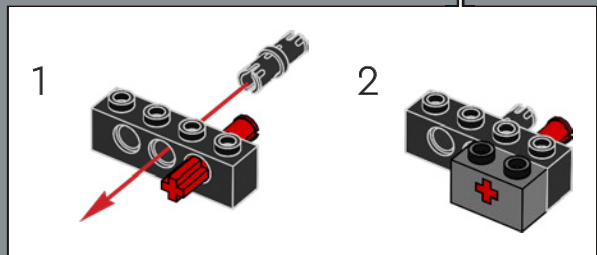
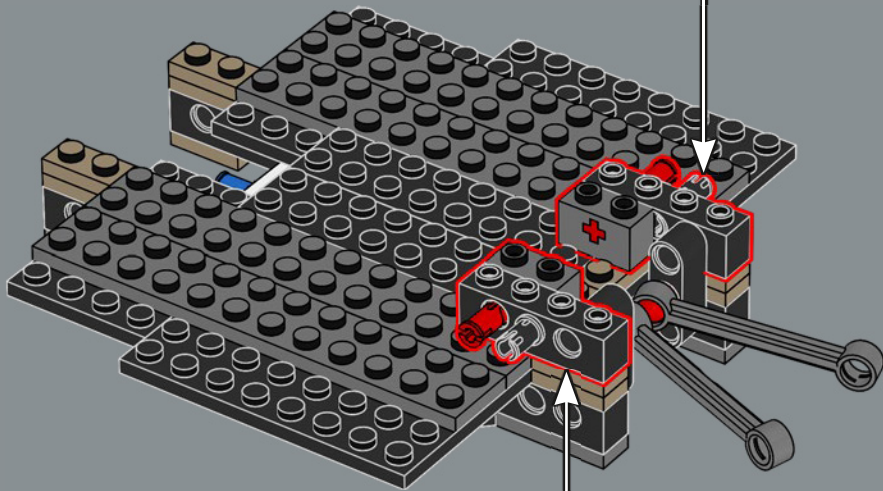
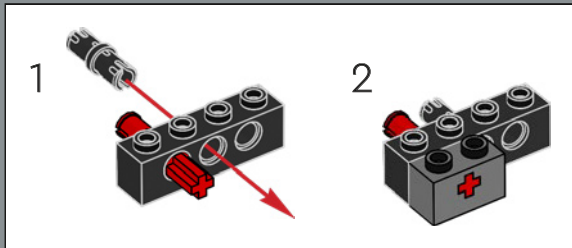

20

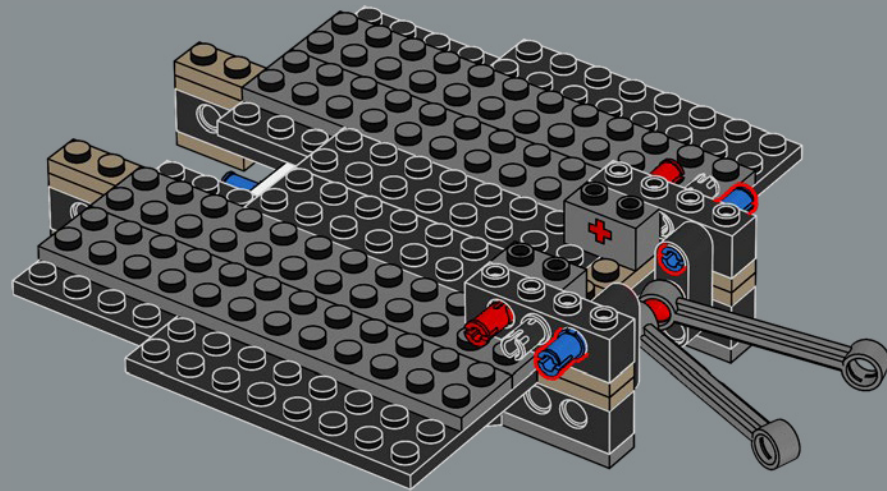

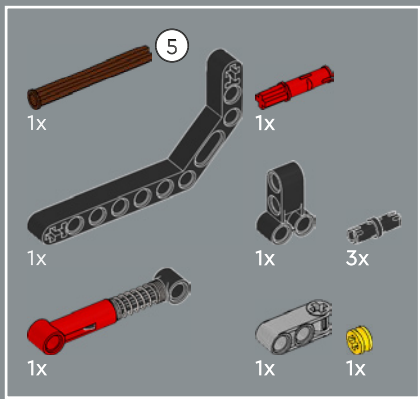

21

1

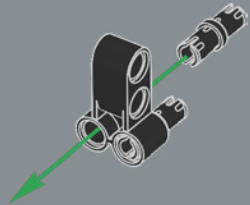

2

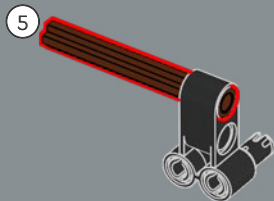

3

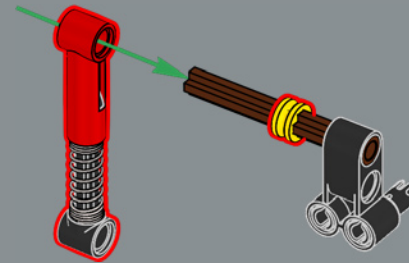

4

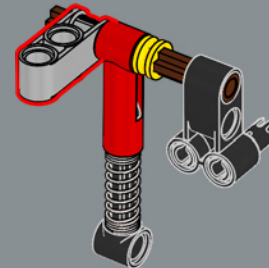

5

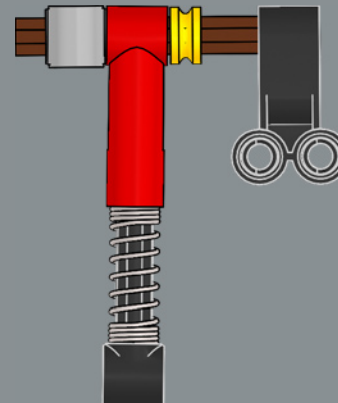

1:1

6

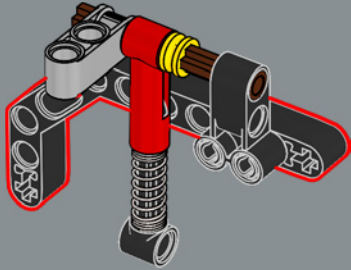

7

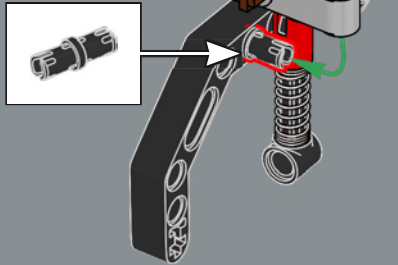

8

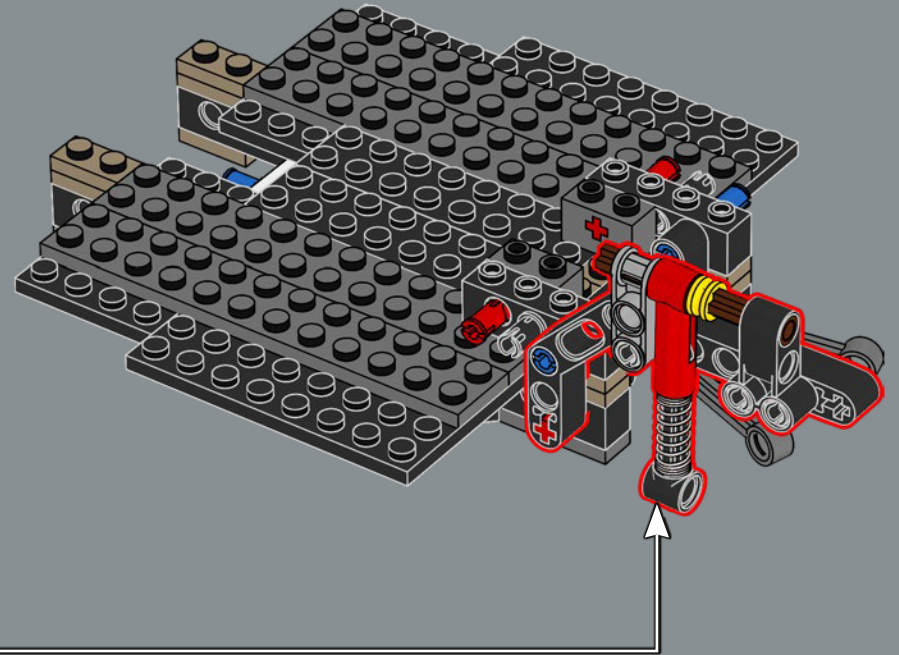
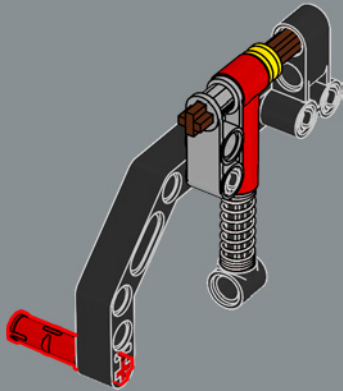

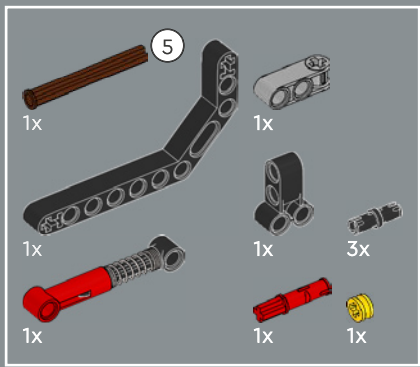

22

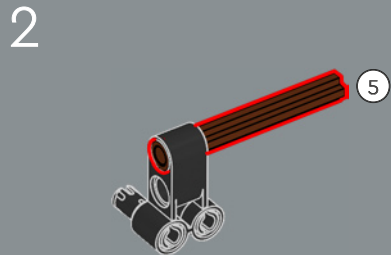
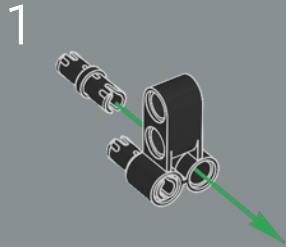

3

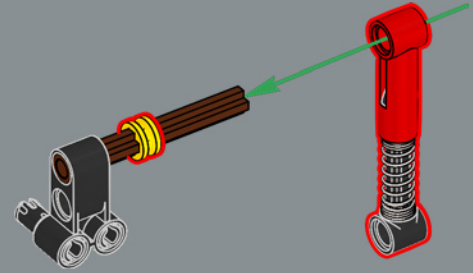

4

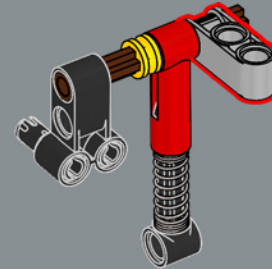

5

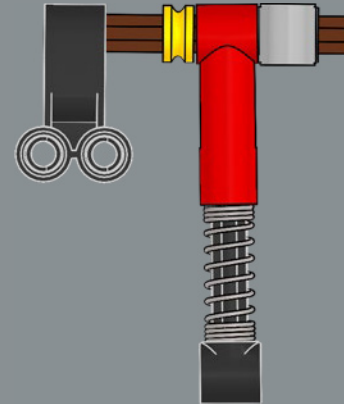

1:1

6

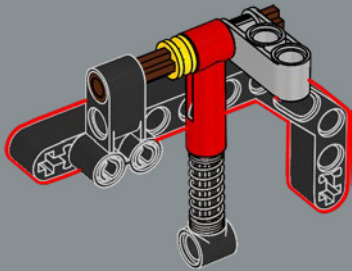

7

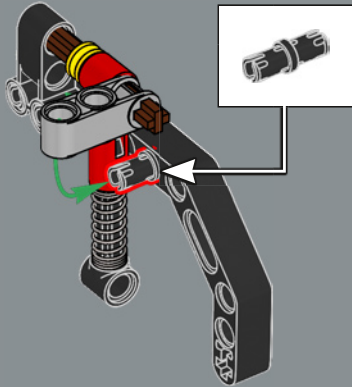

8

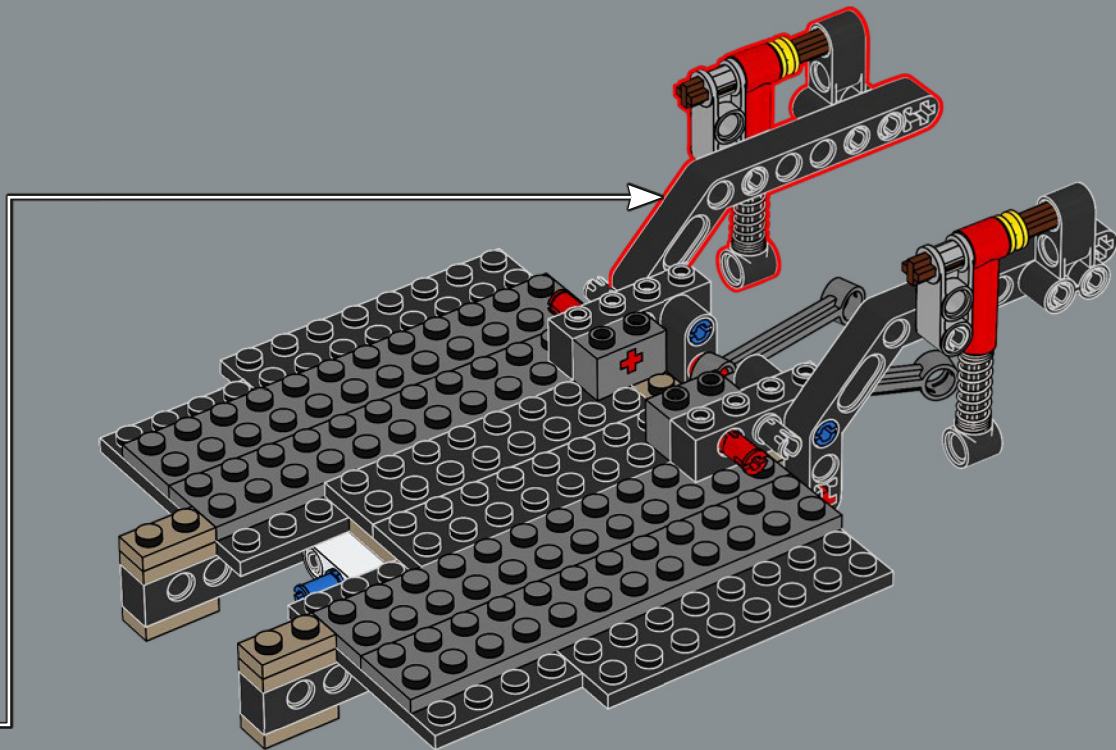
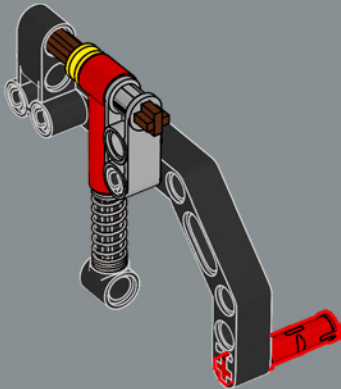

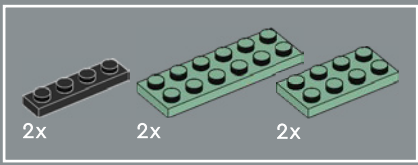

23

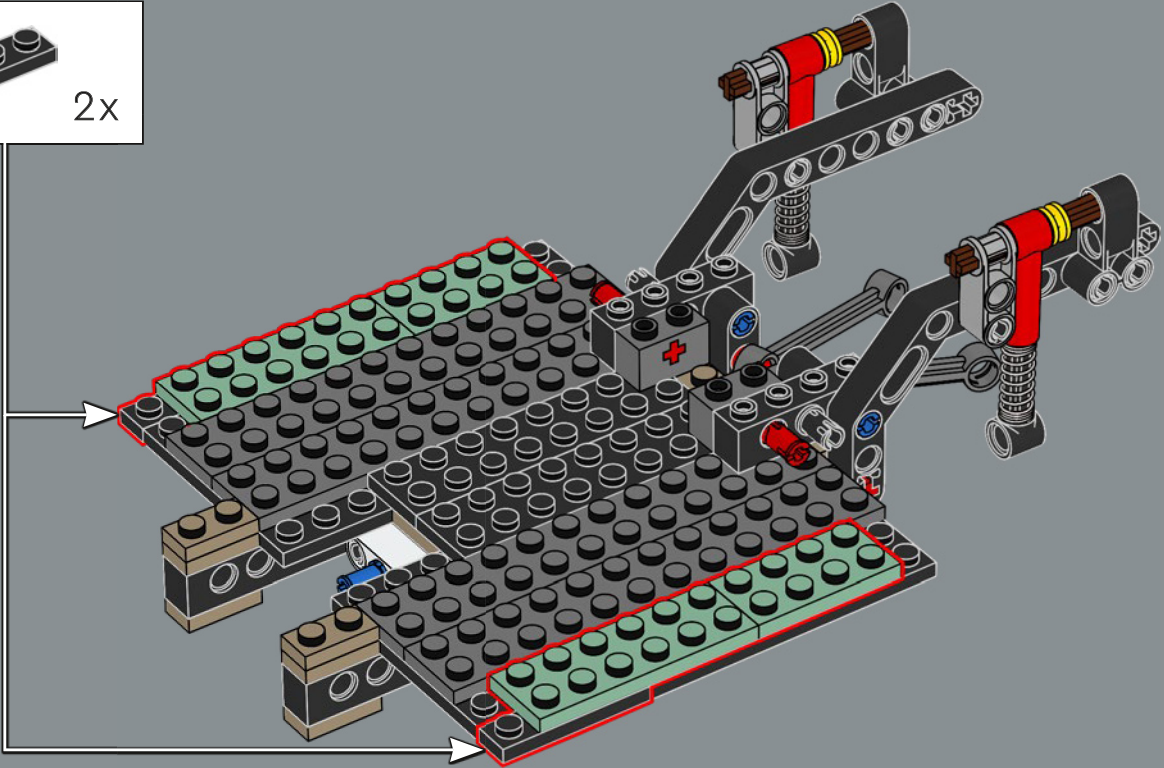
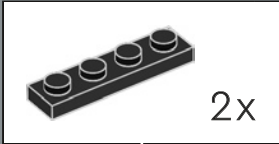

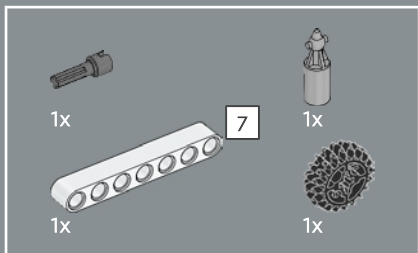

24

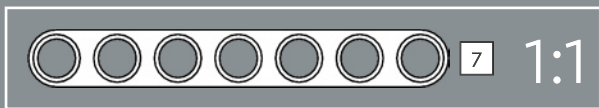
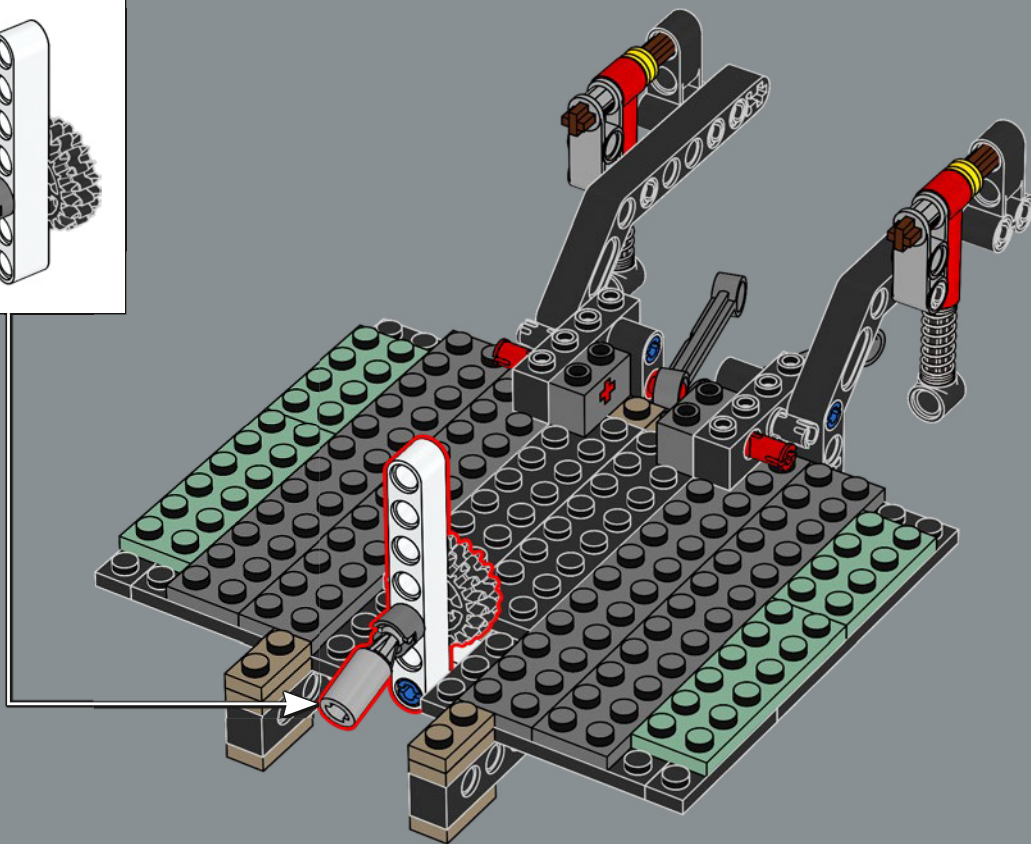
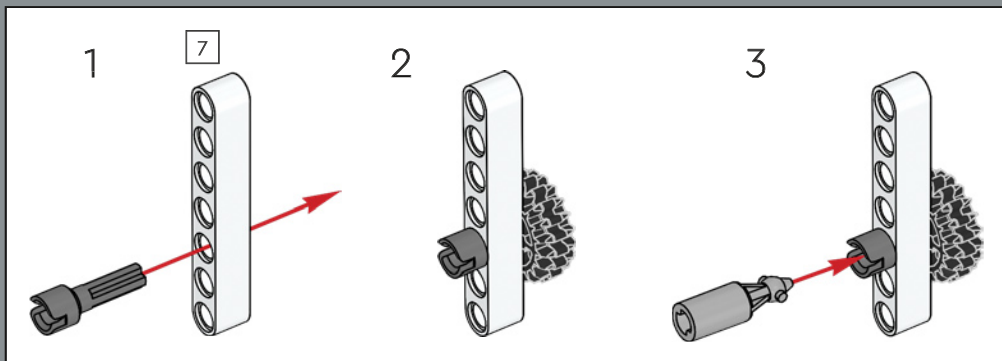

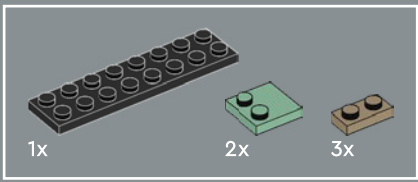

25

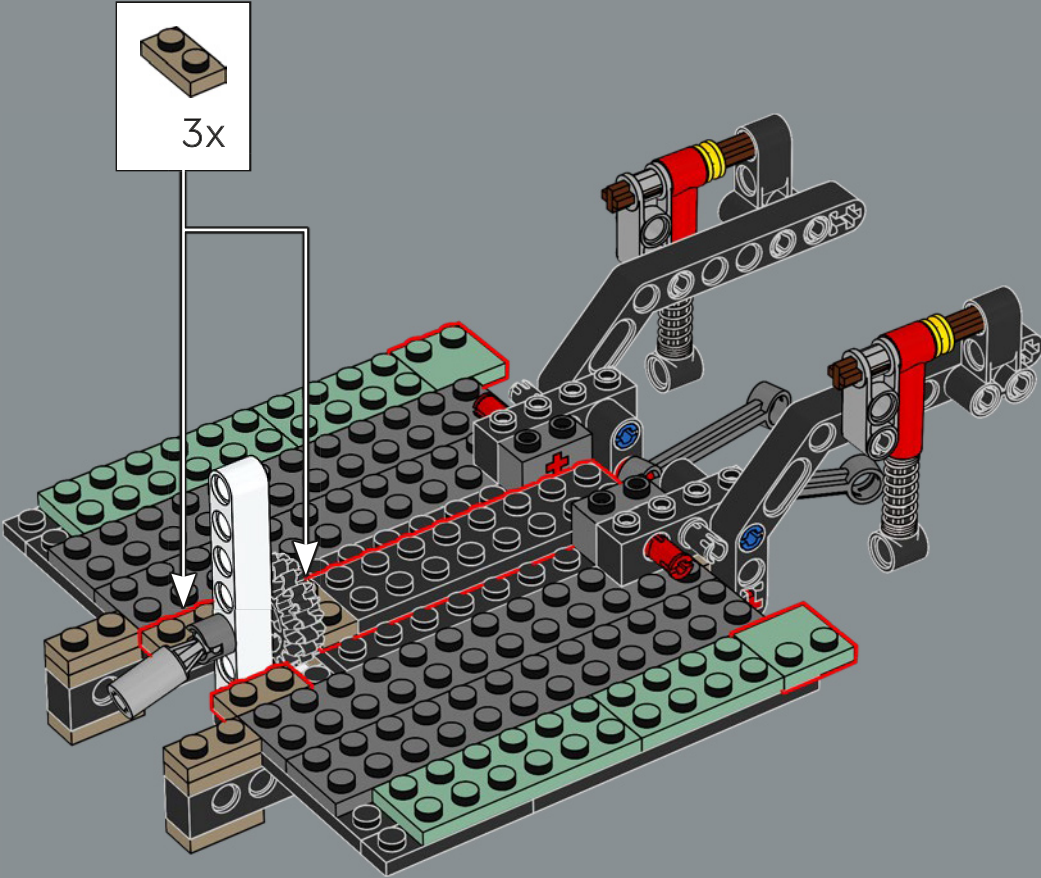

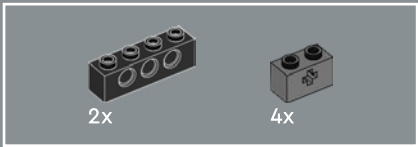

26

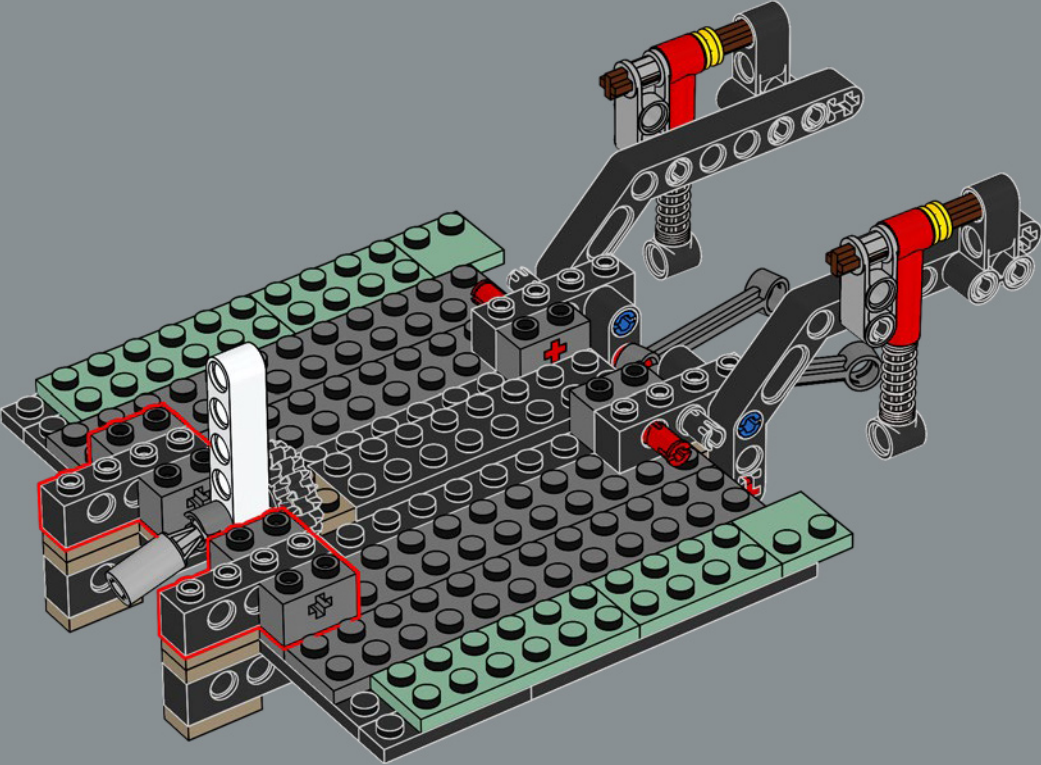

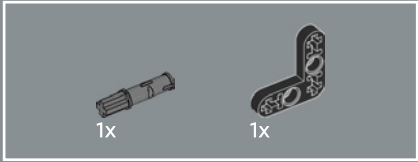
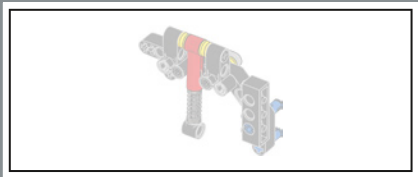

27



28

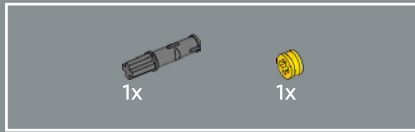
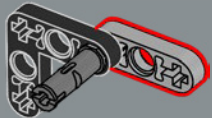

29

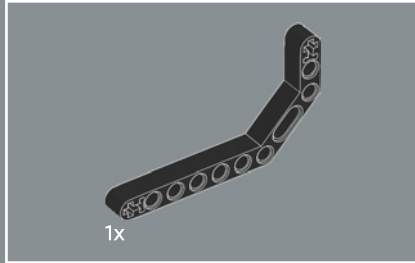
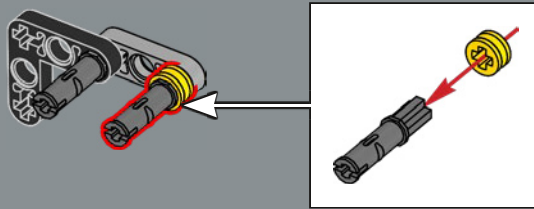

30

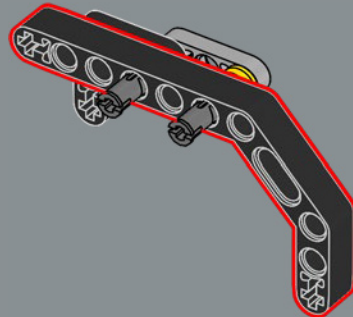

31

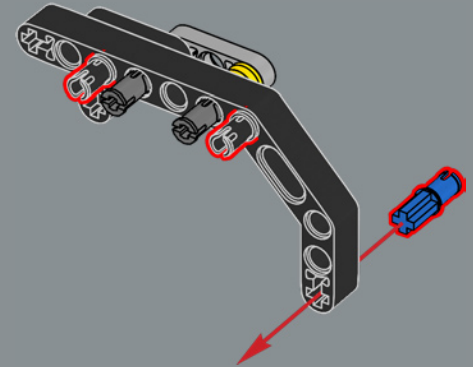

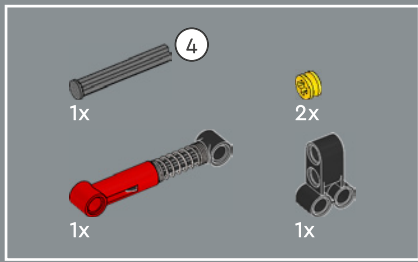

32

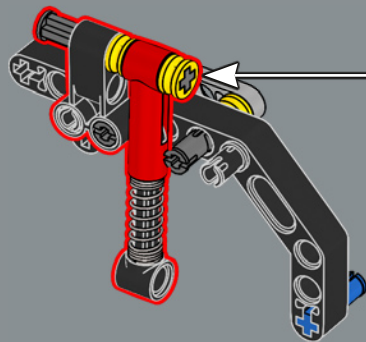
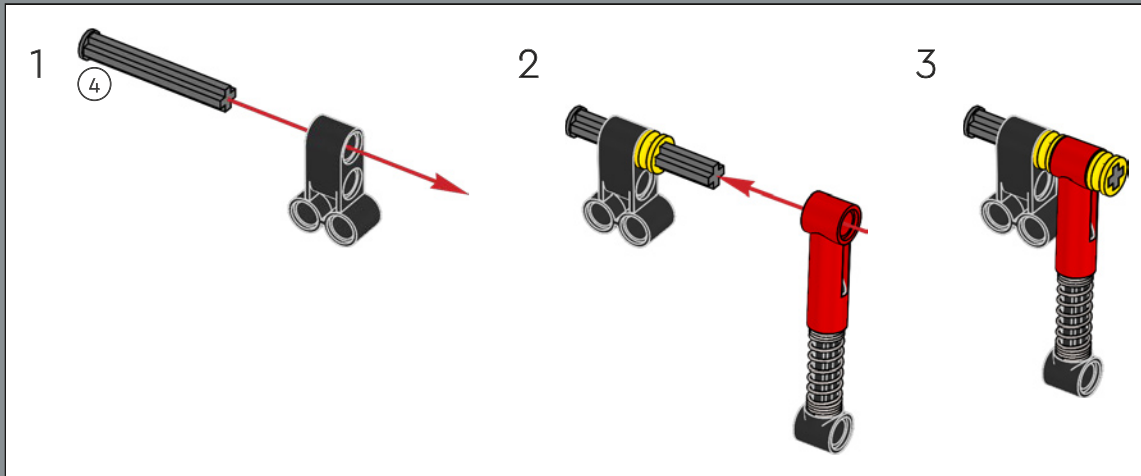

33

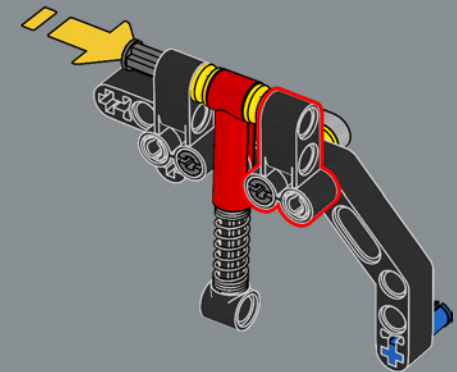



34

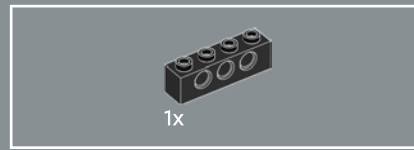
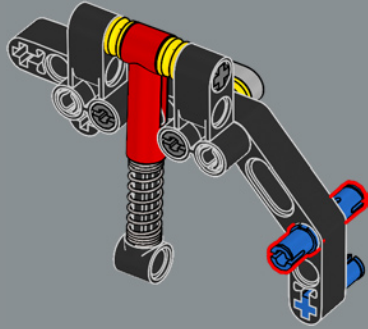

35

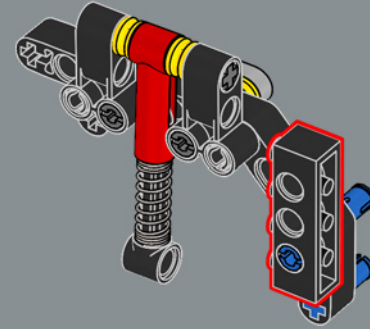

36

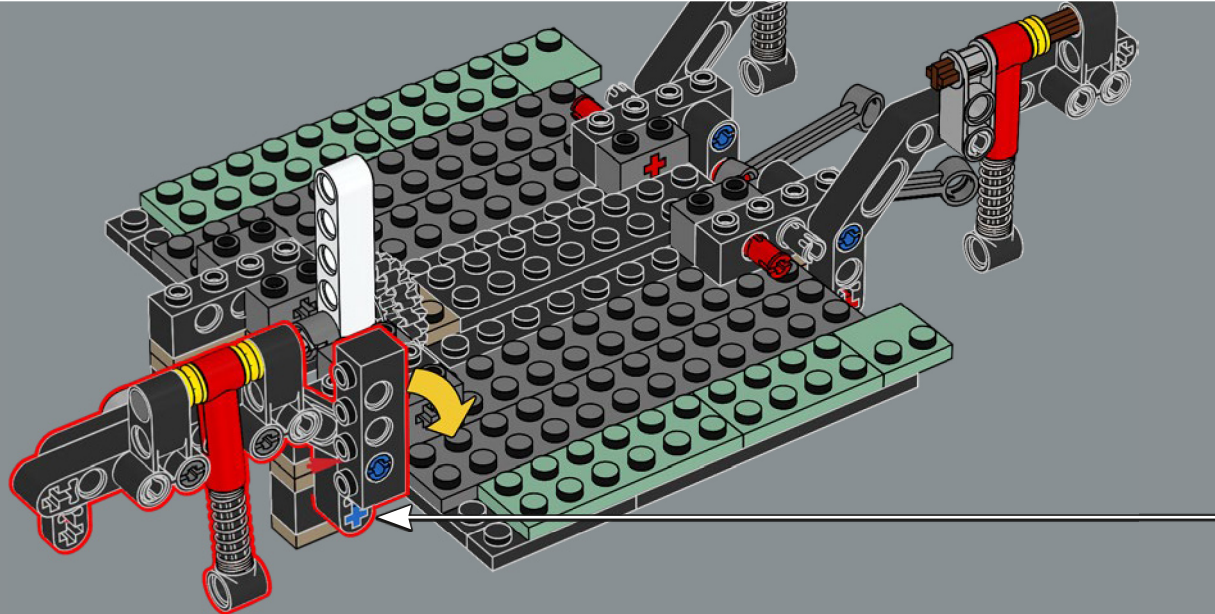

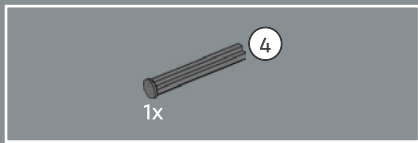

37

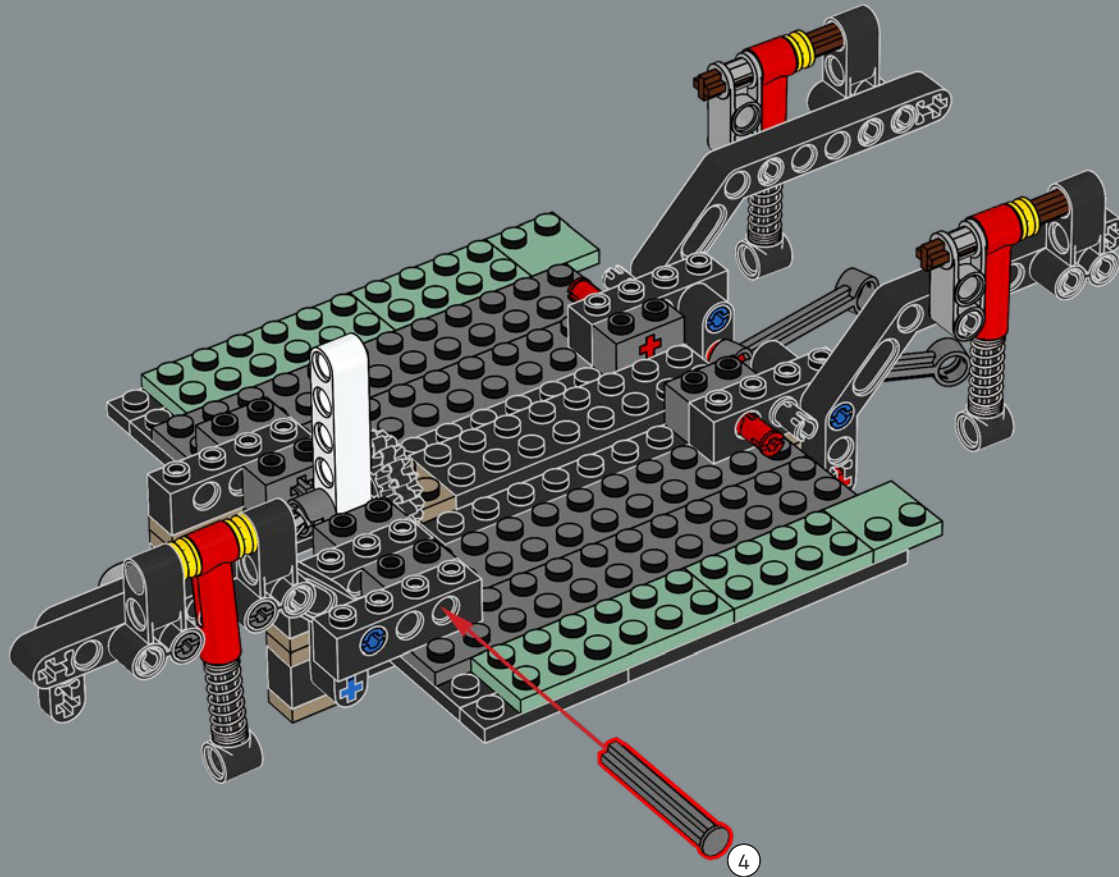

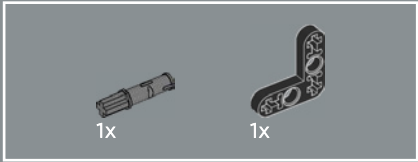
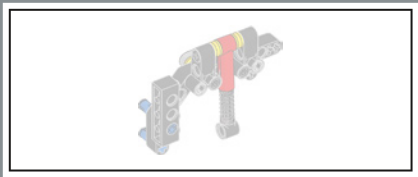

38

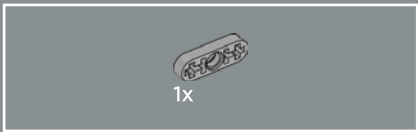
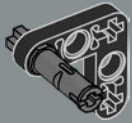

39

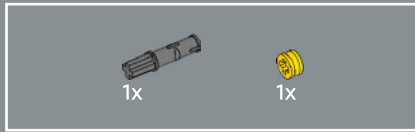

40

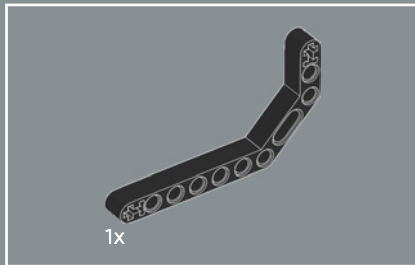
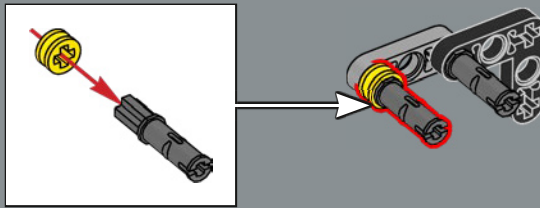

41

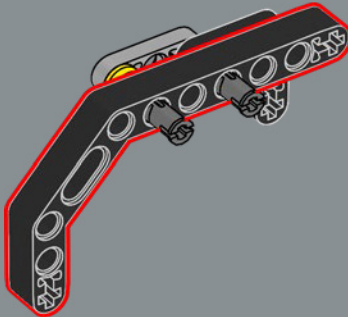

42

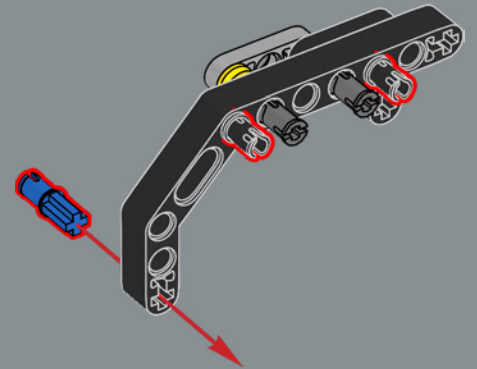

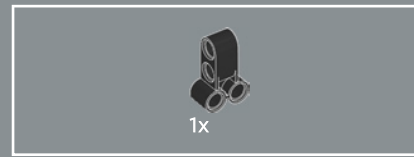
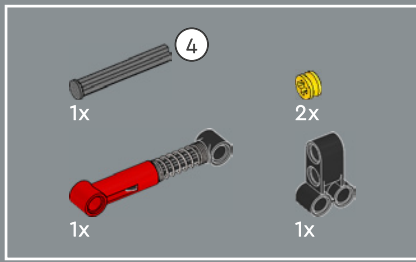

43

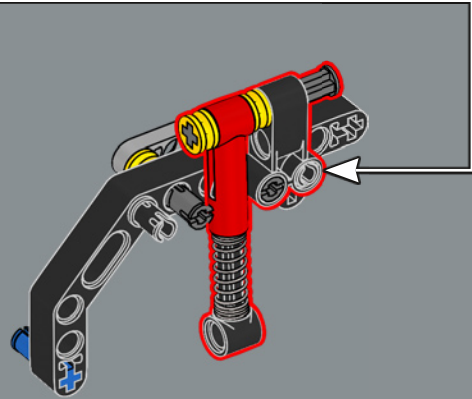
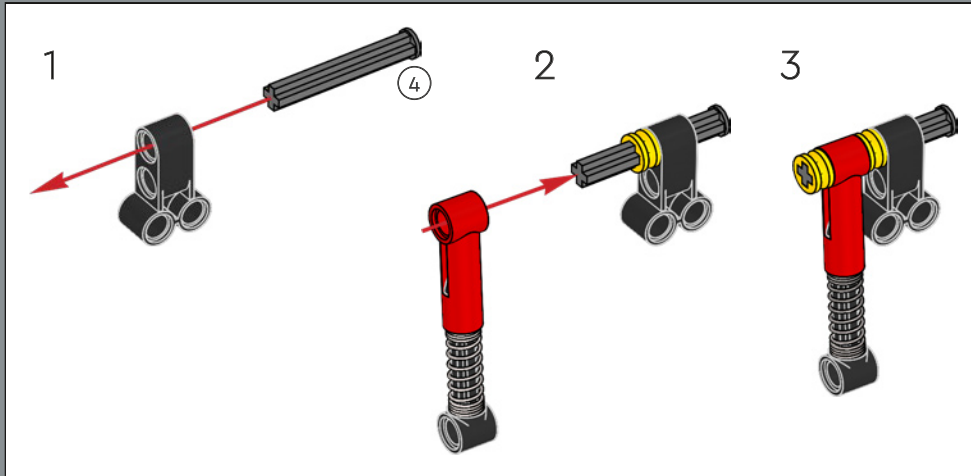

44

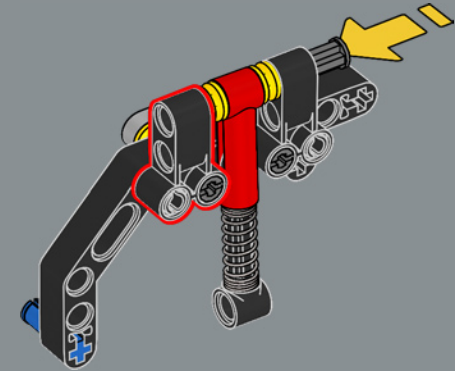



45

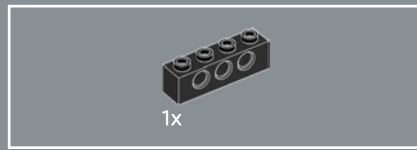
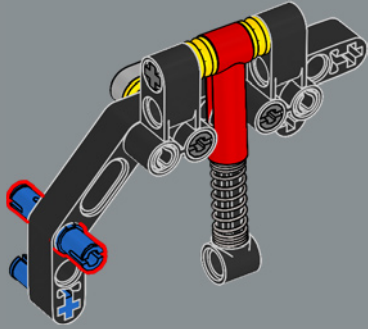

46

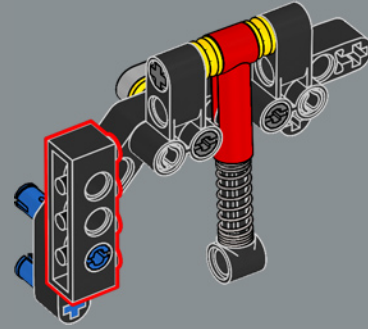

47

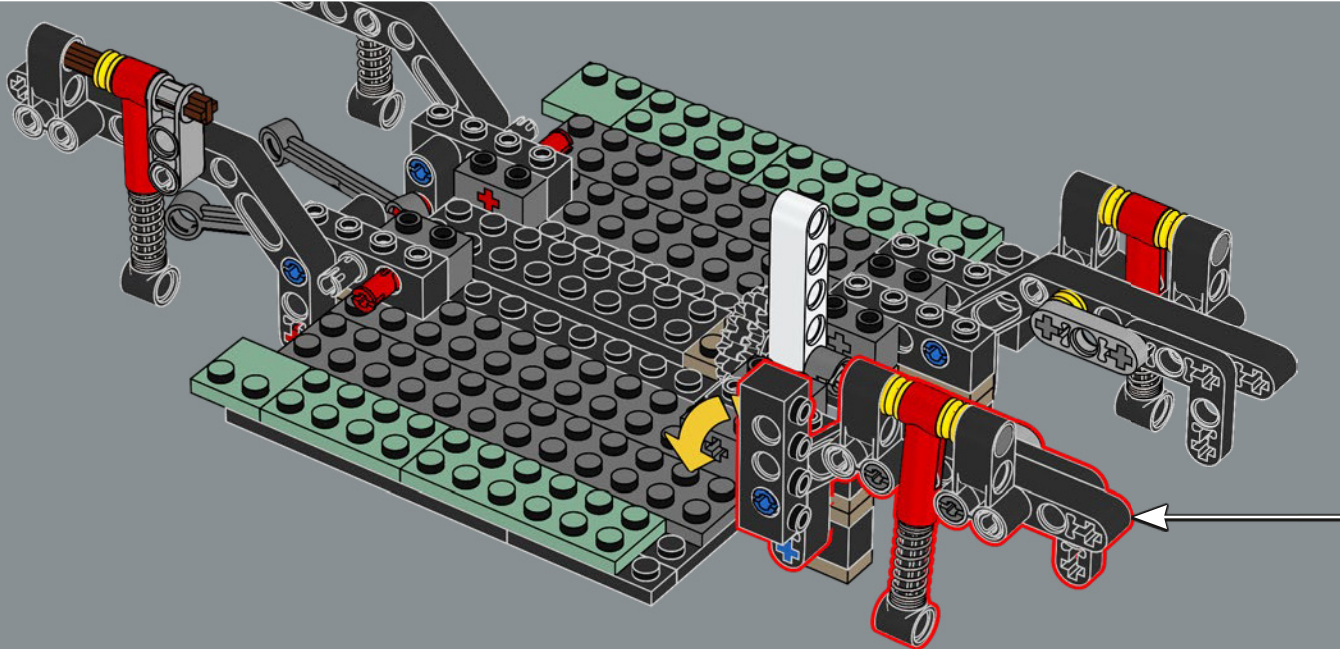

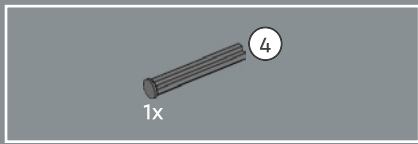

48

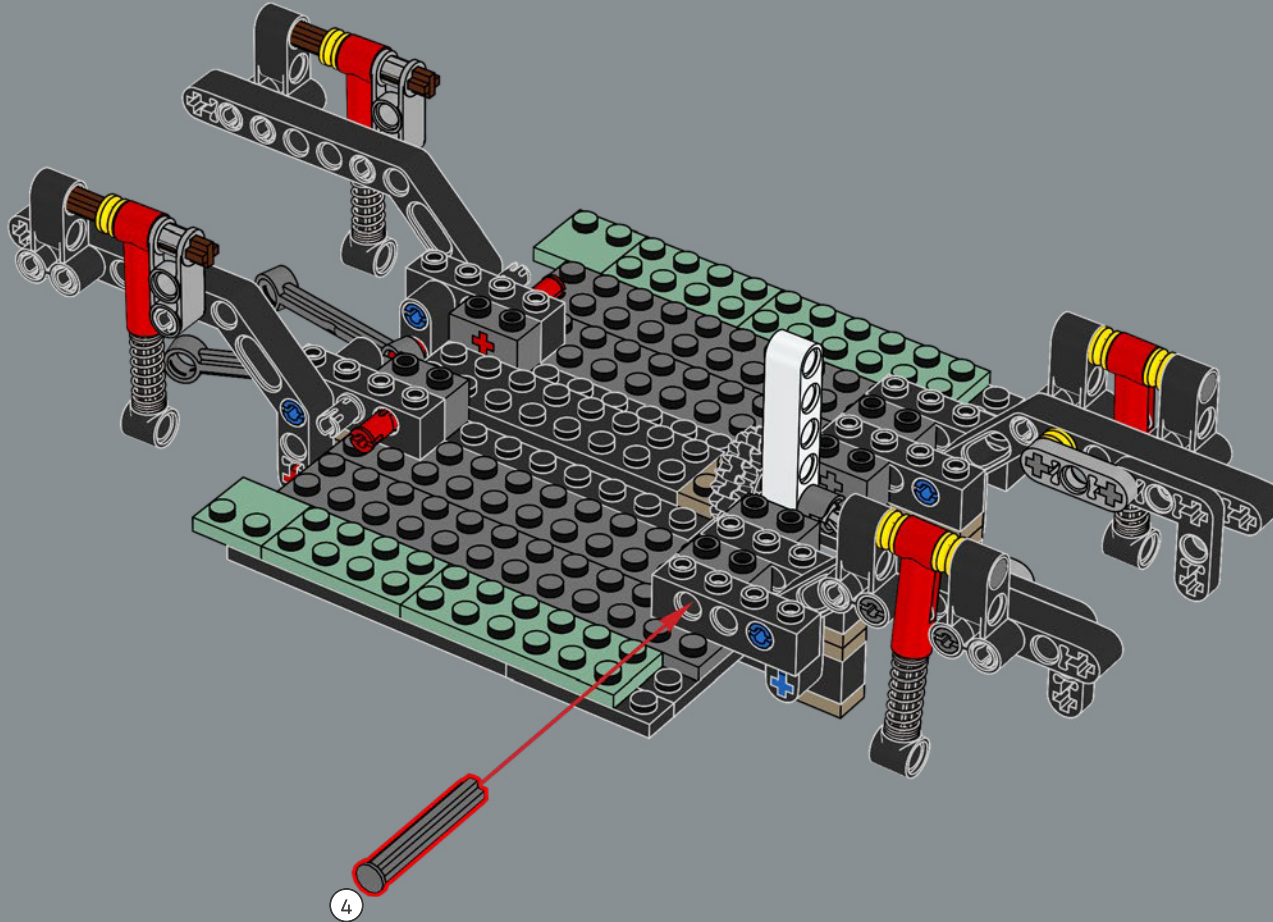

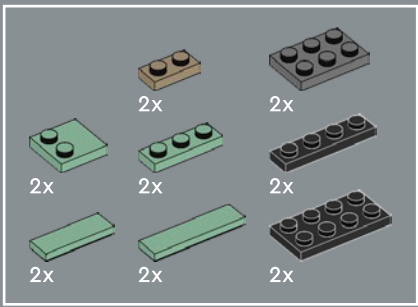

49

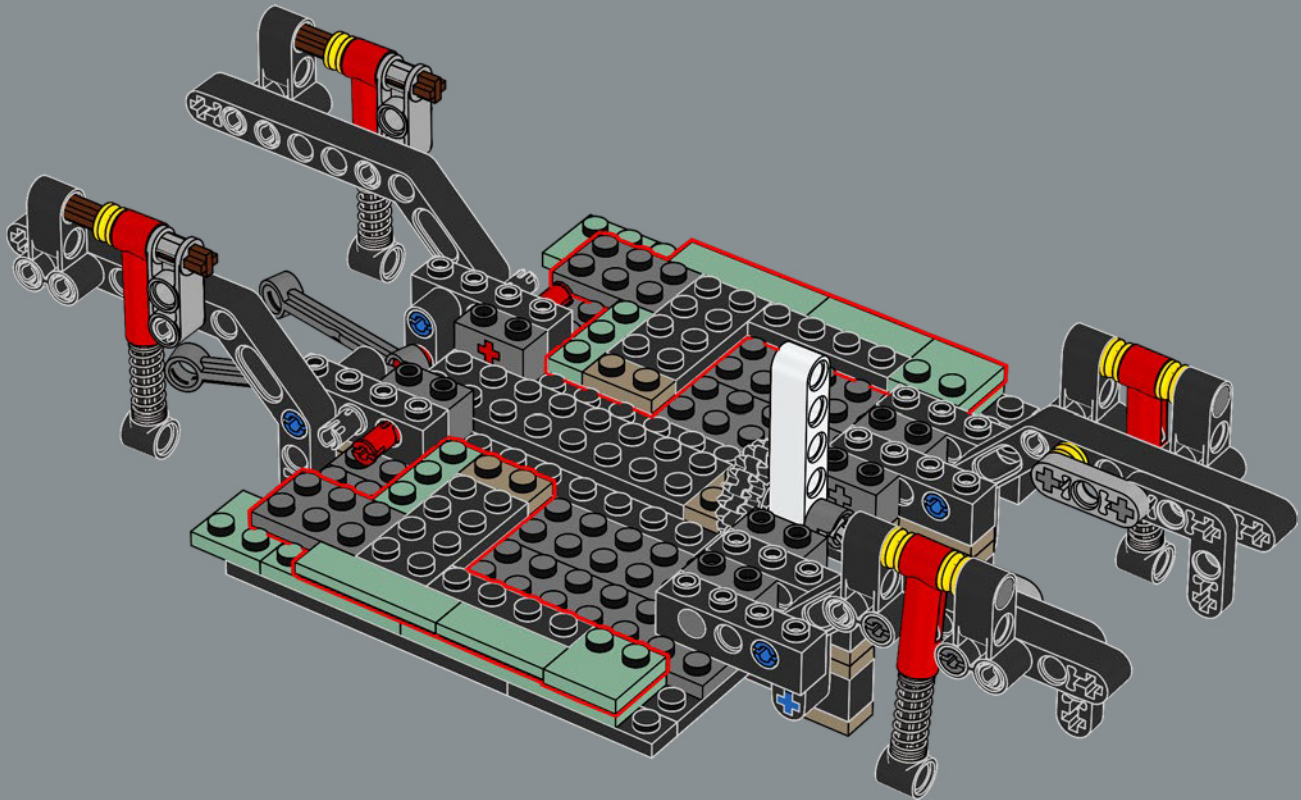

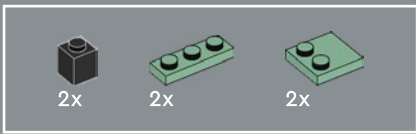

50

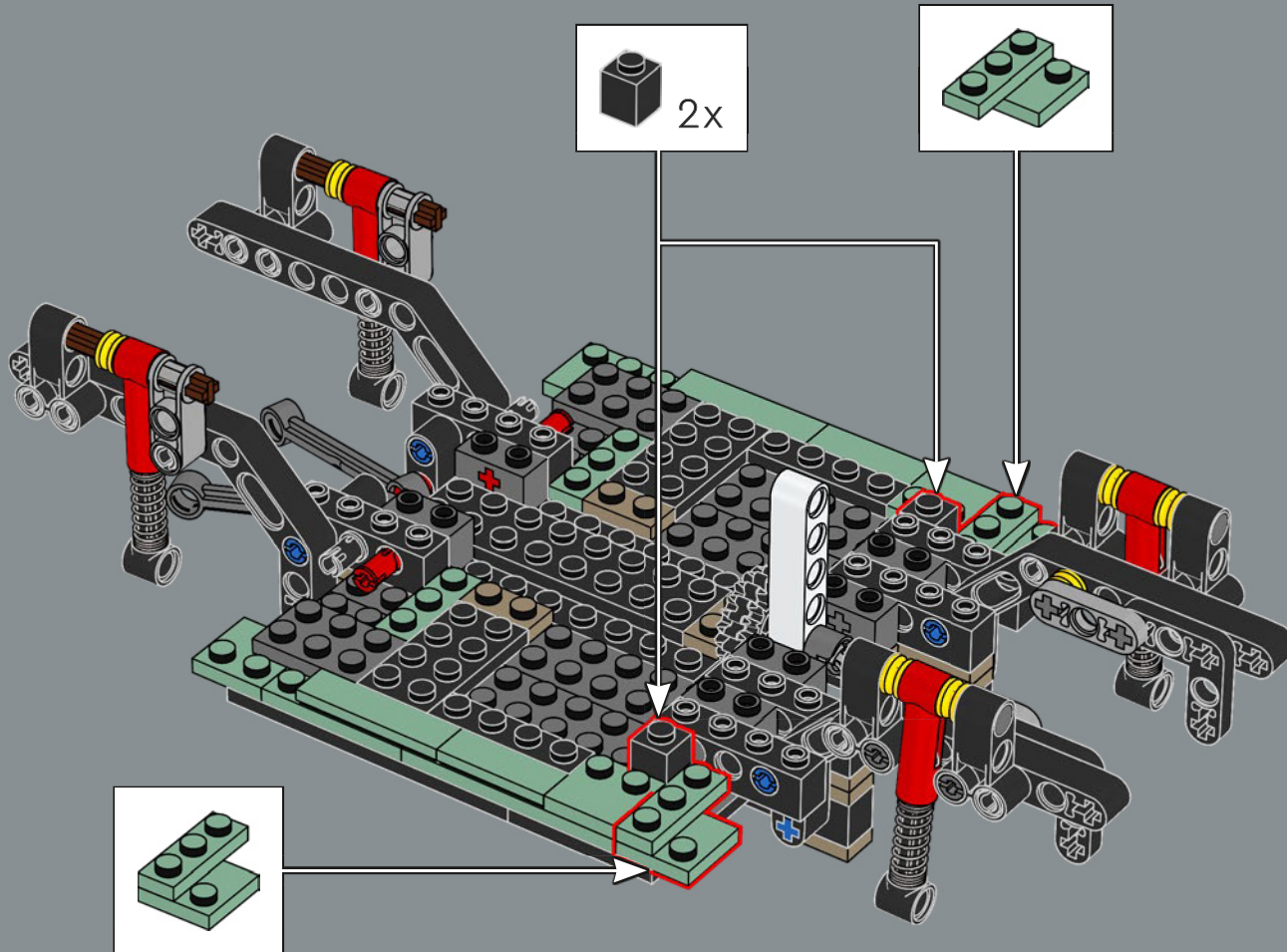



51

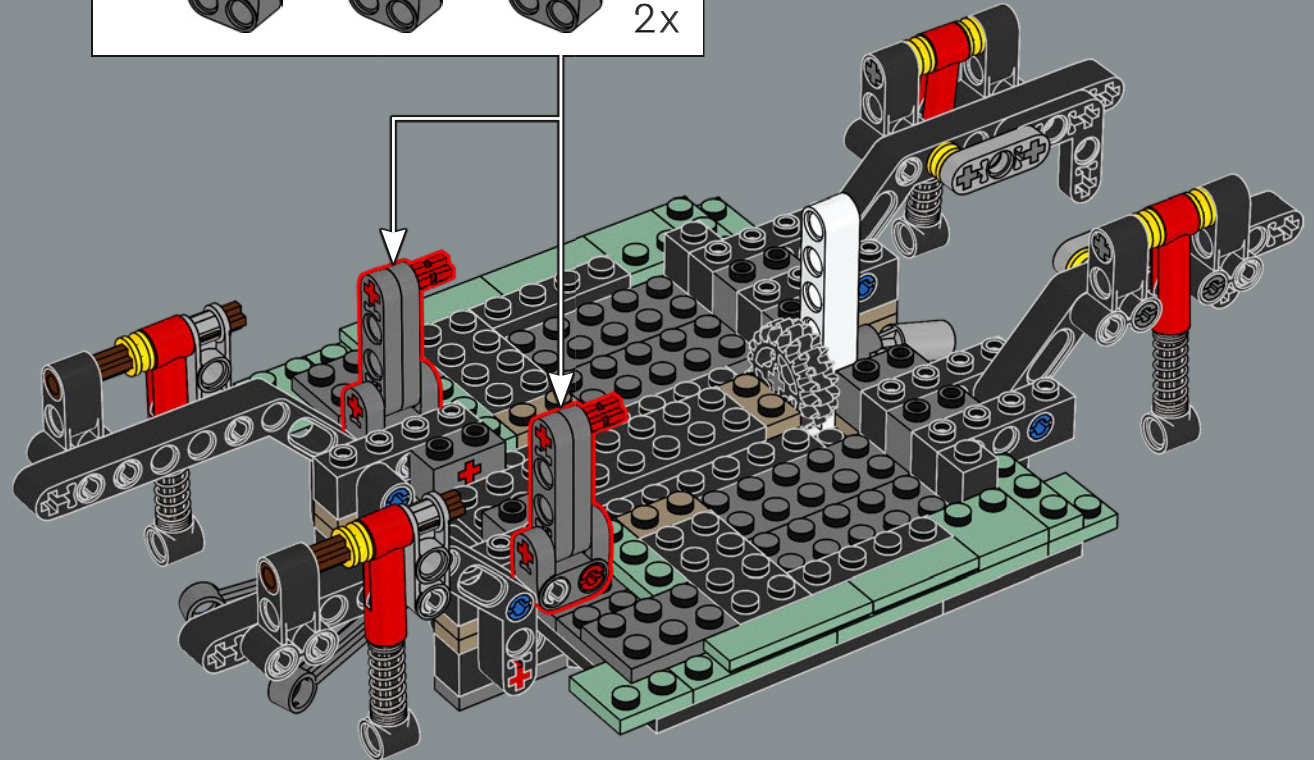
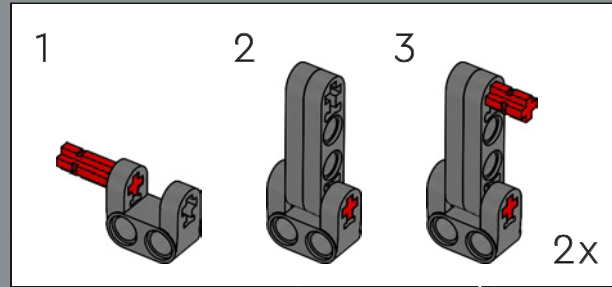

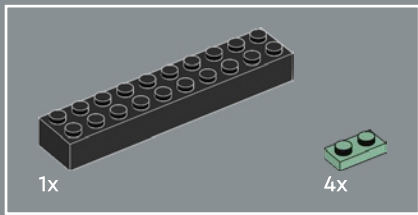

52

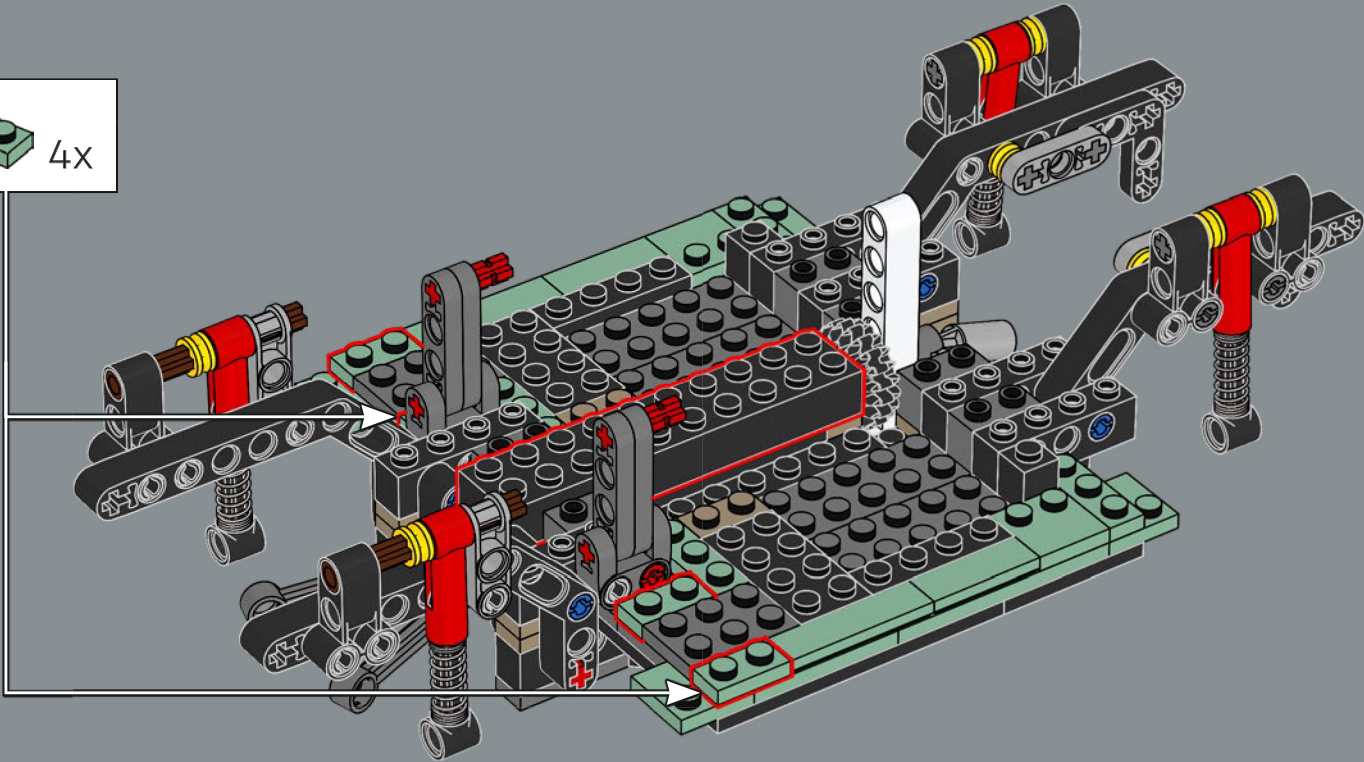
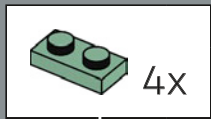

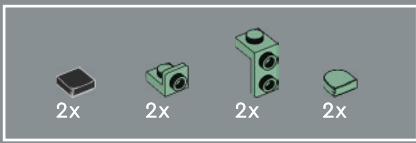

53

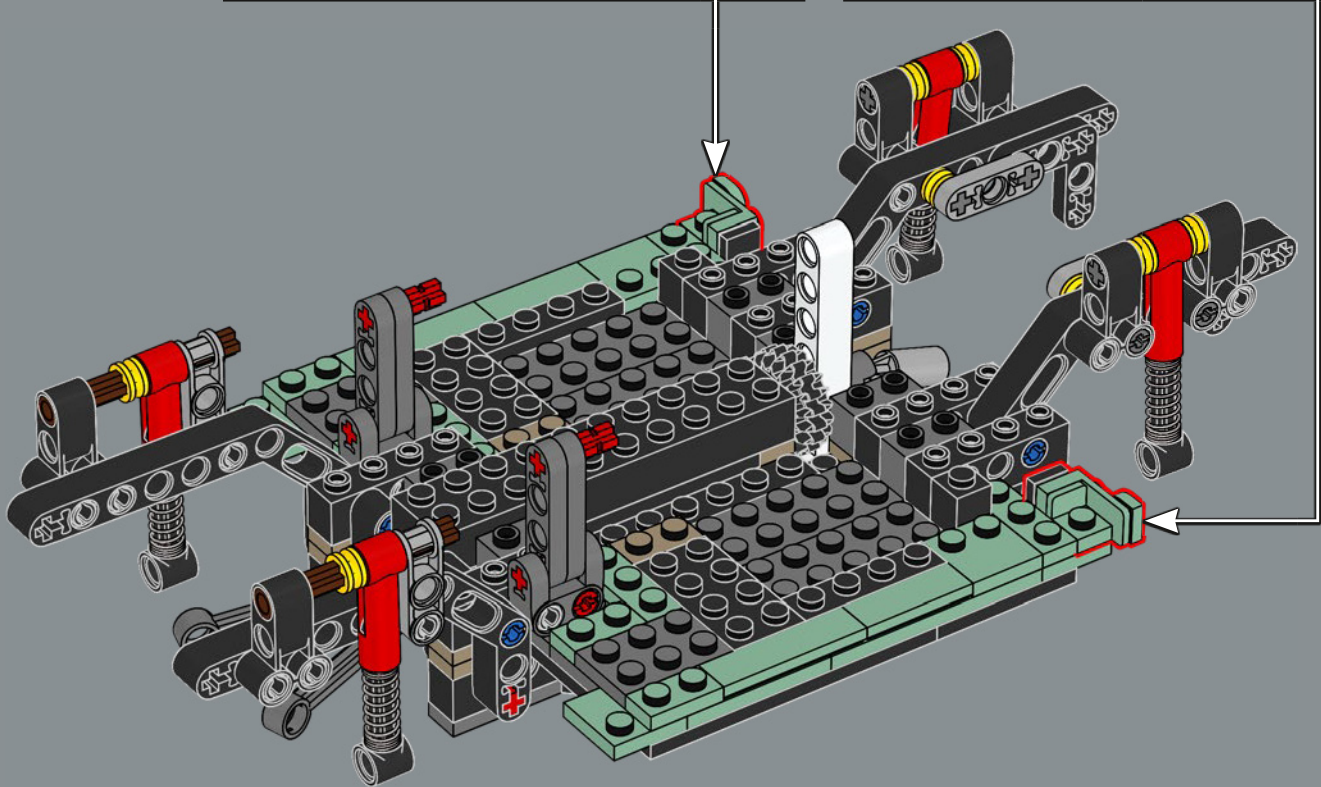
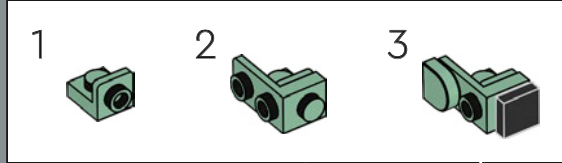
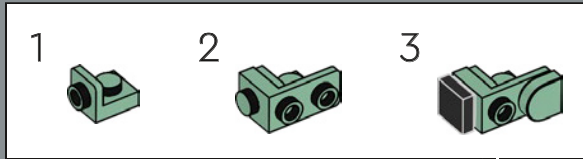

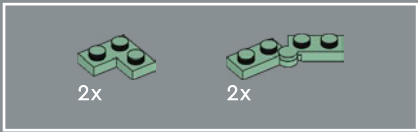

54

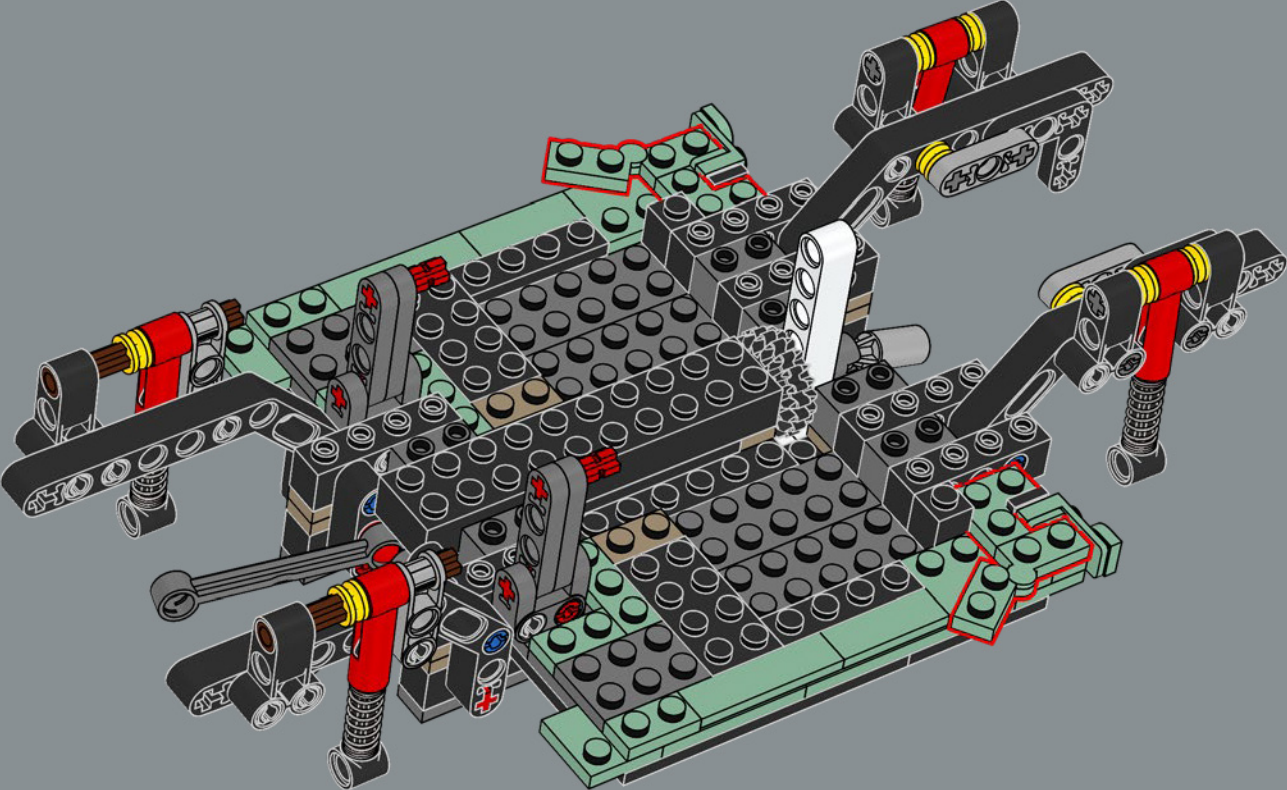

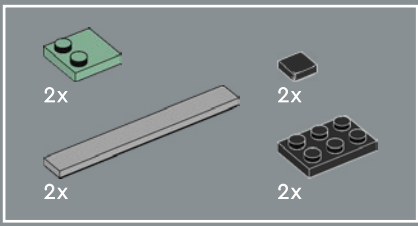

55

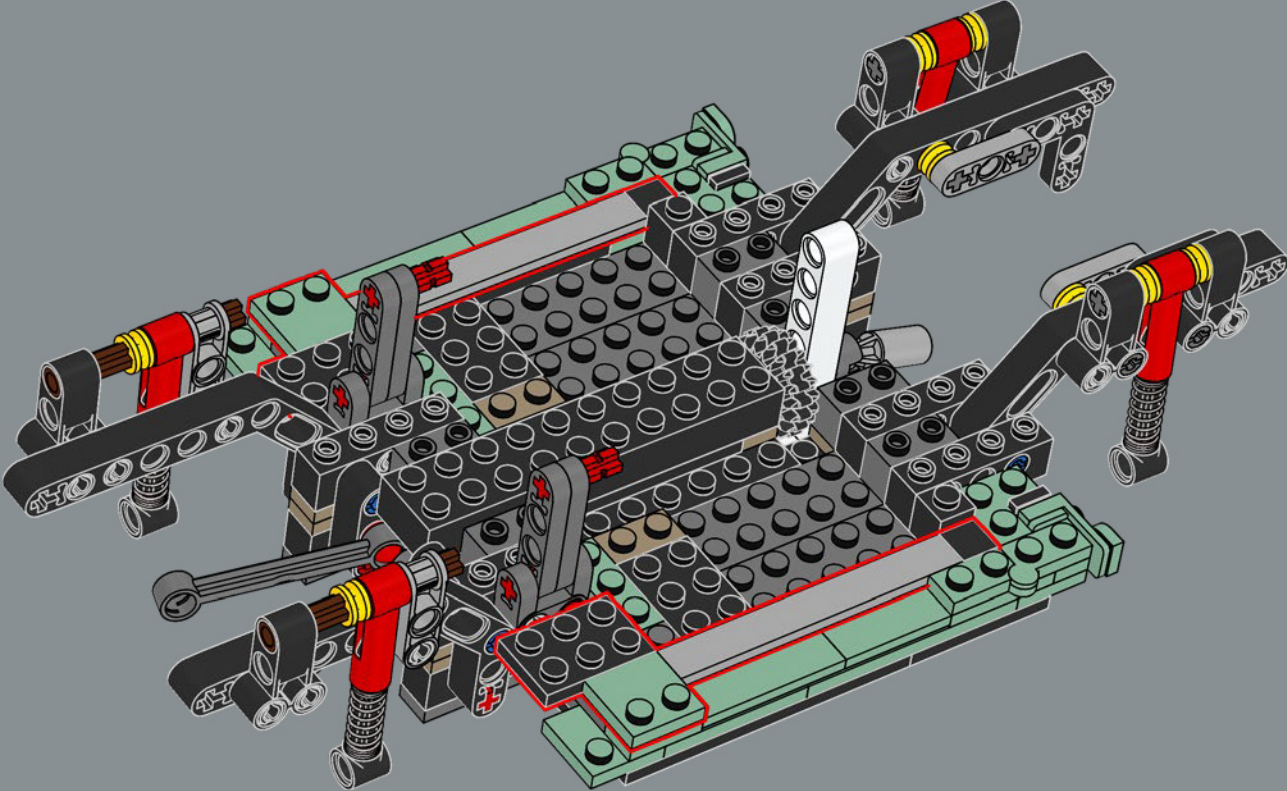

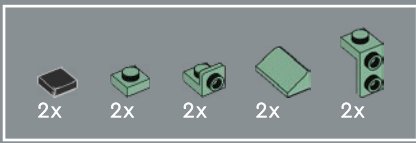

56

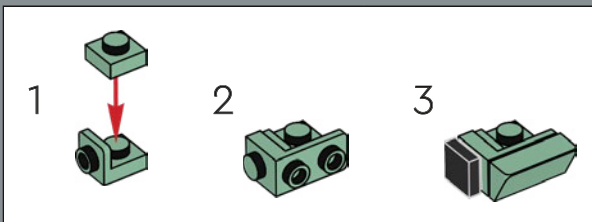
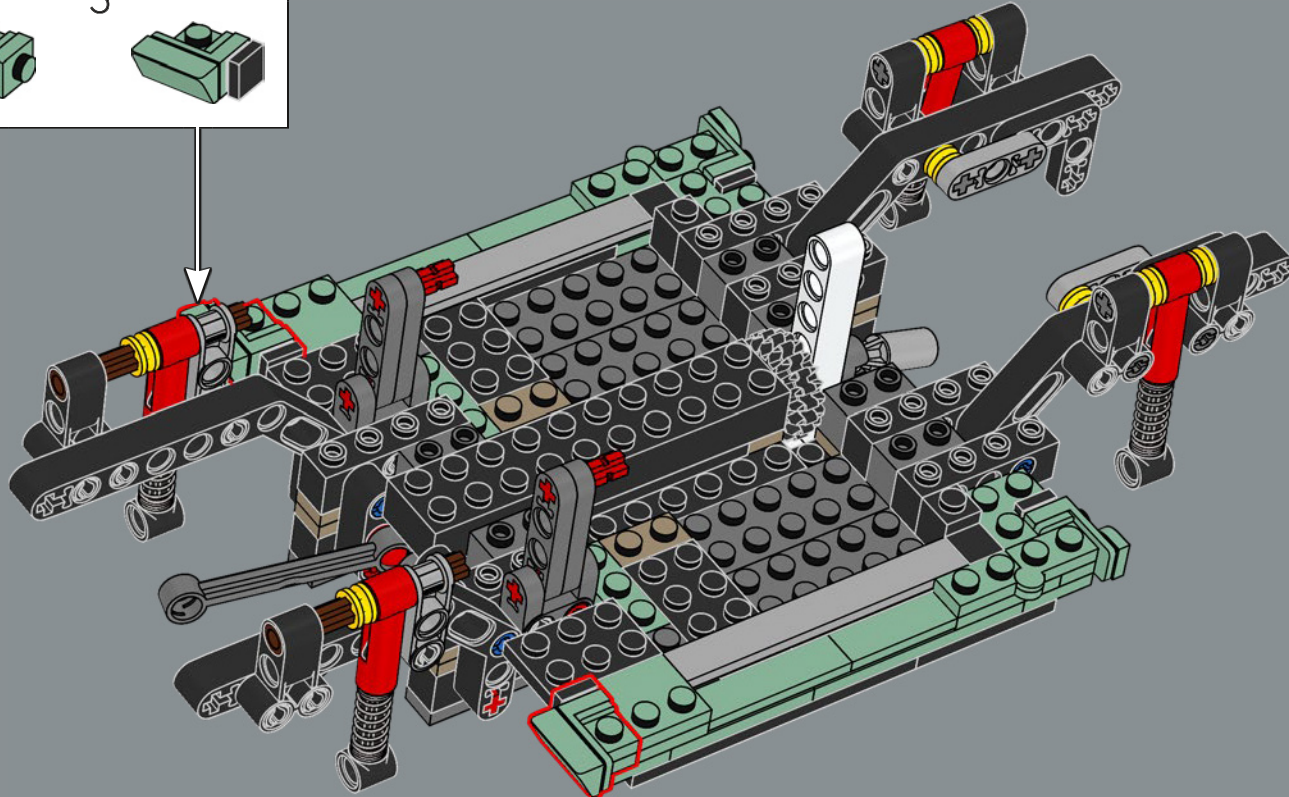
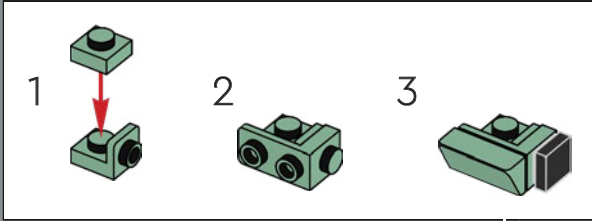

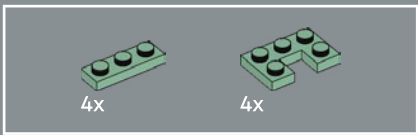

57

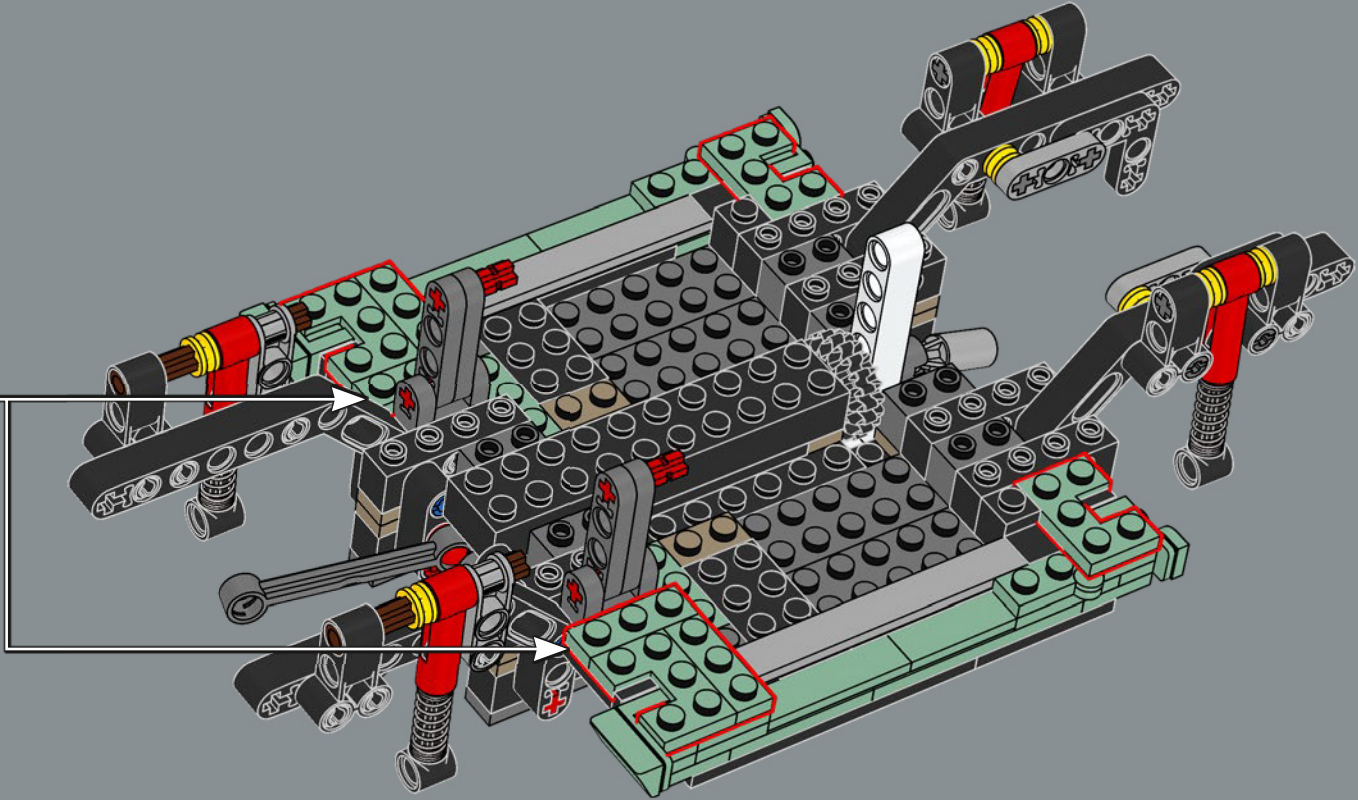
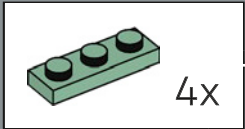

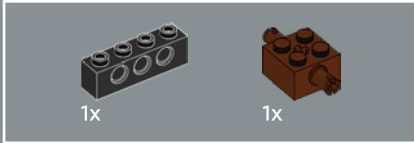
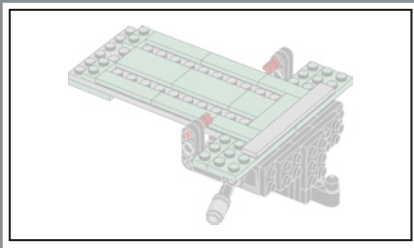

58

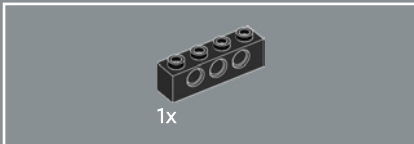
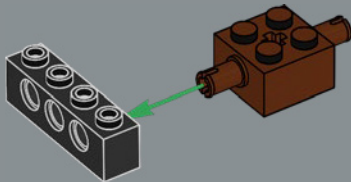

59

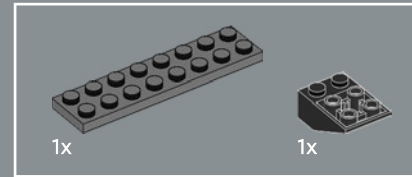
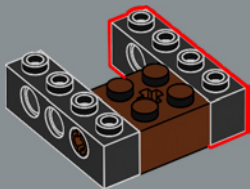

60

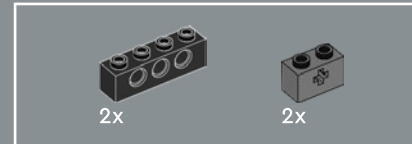
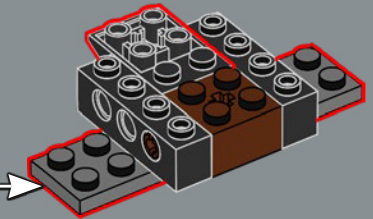
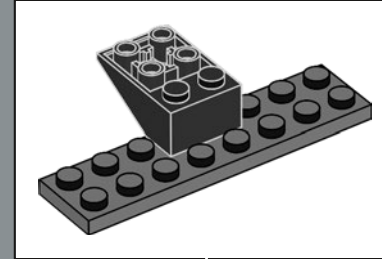

61

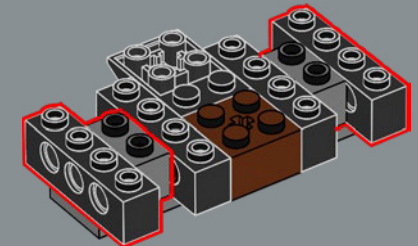



4x

62

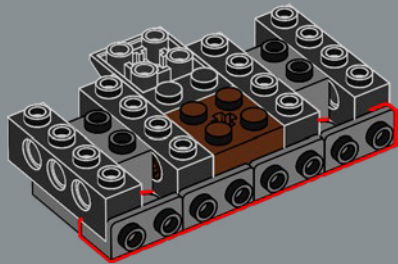

2x

63

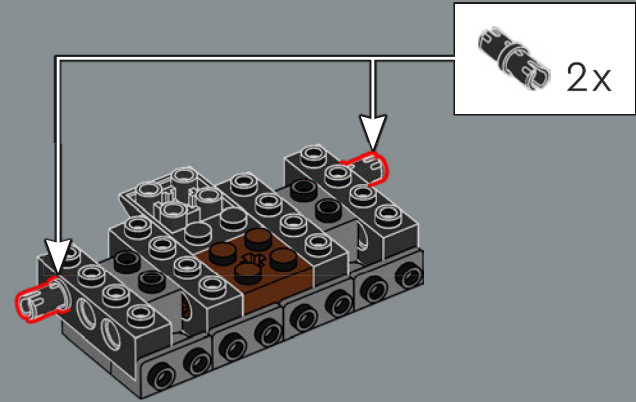

2x



2x

4

64

4

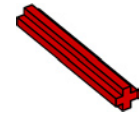

2x

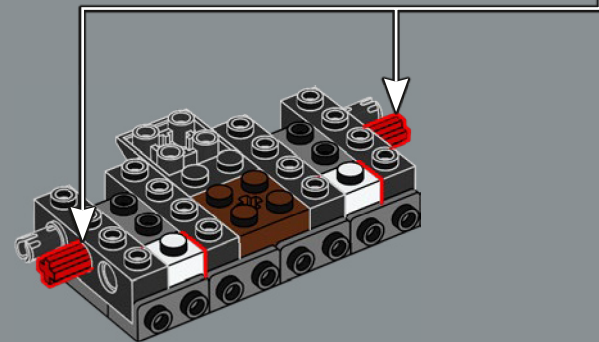

4

1:1



65

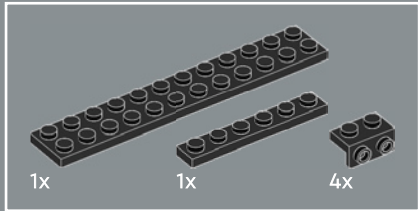
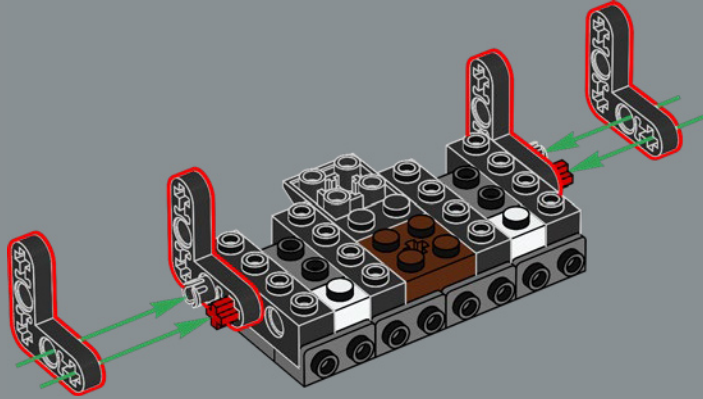

66

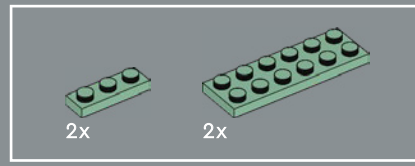
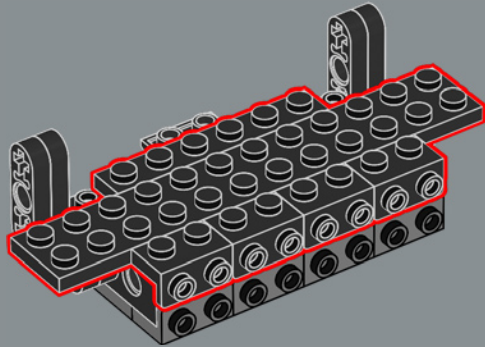

67

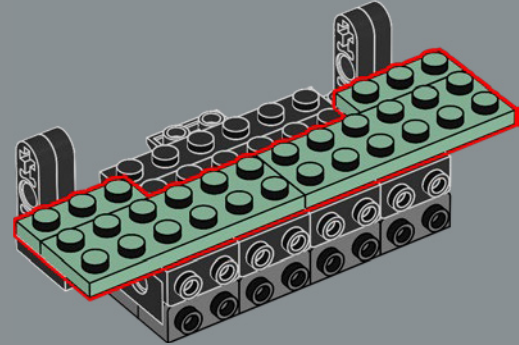

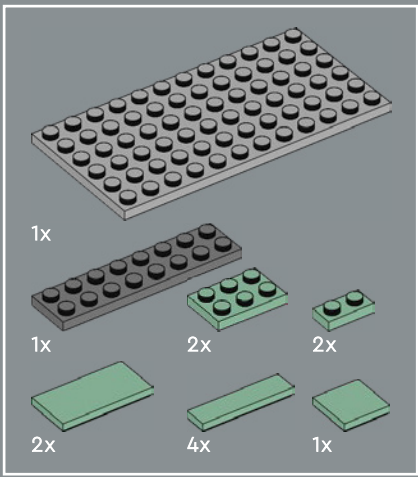

68

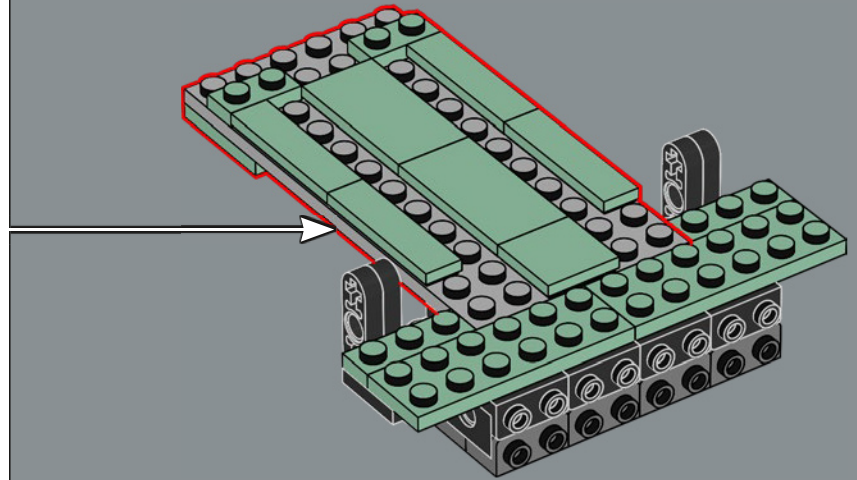
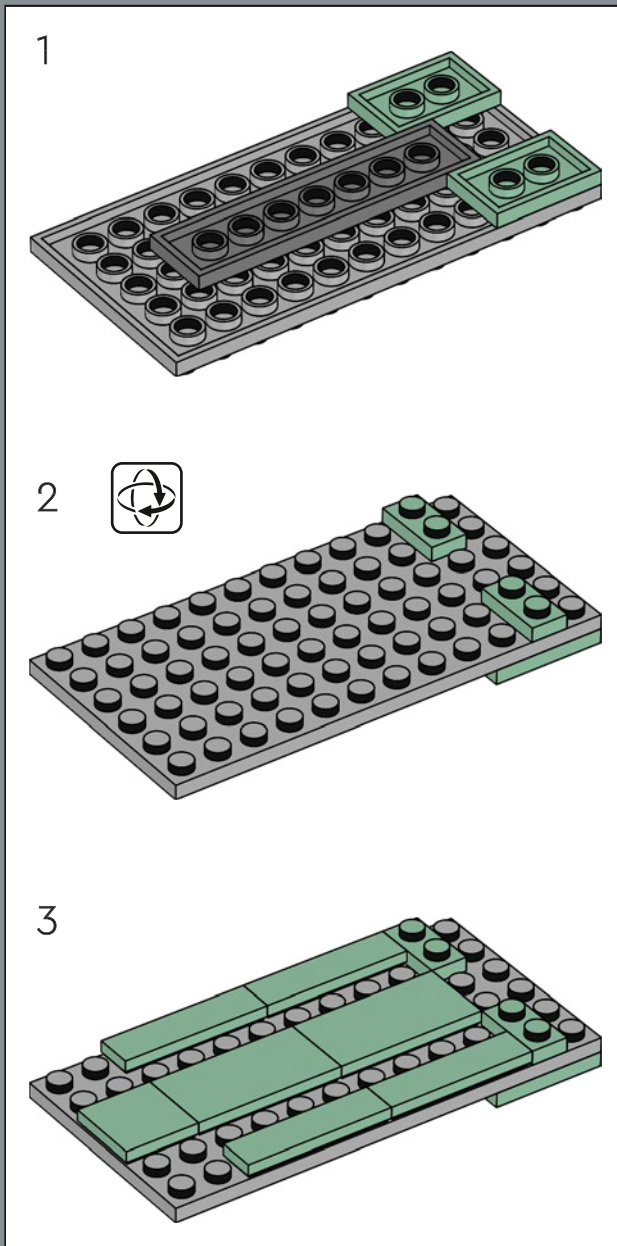

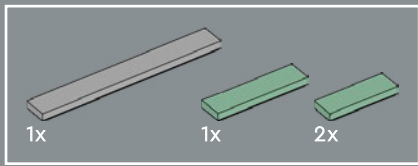

69

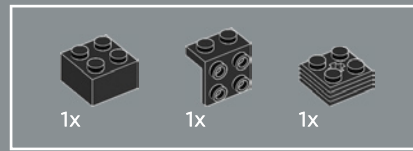
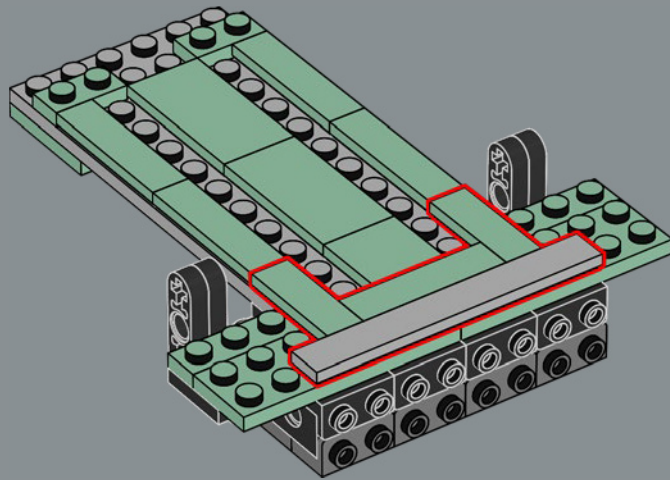

70

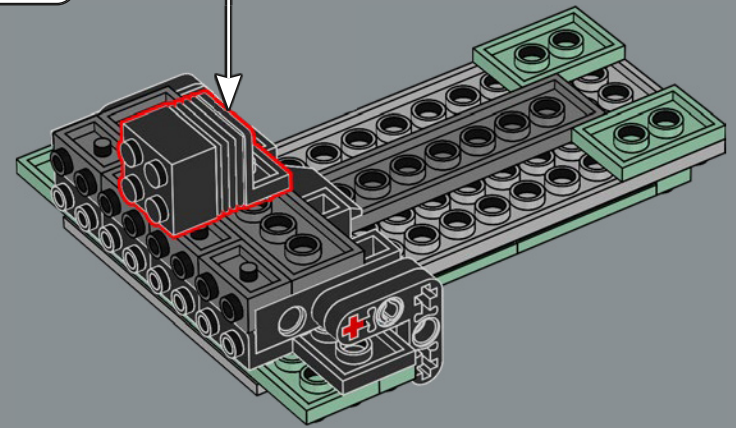
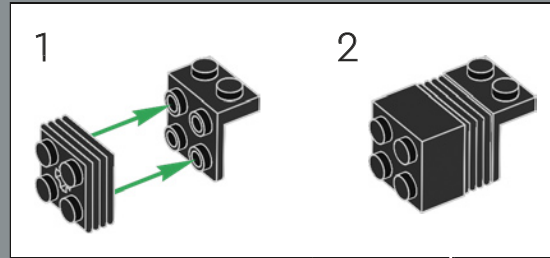

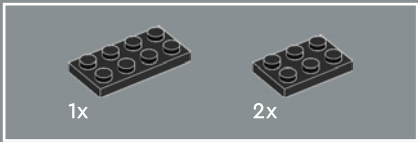

71

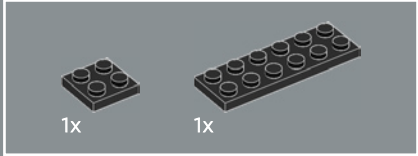
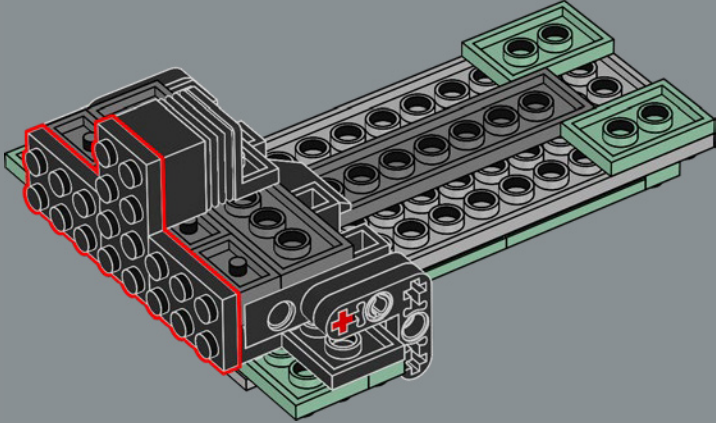

72

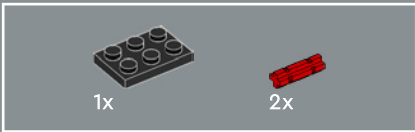
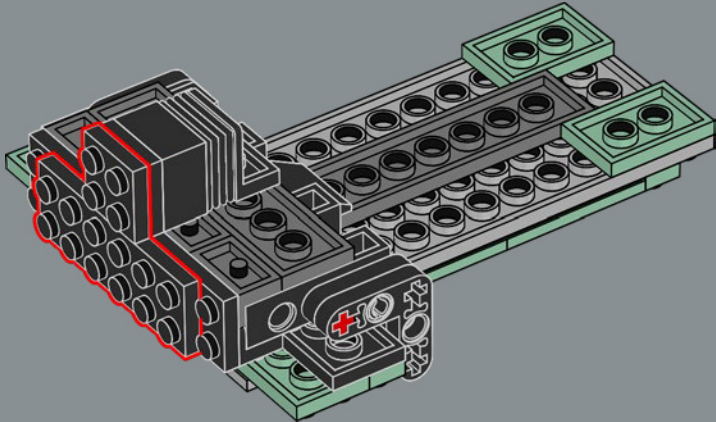

73

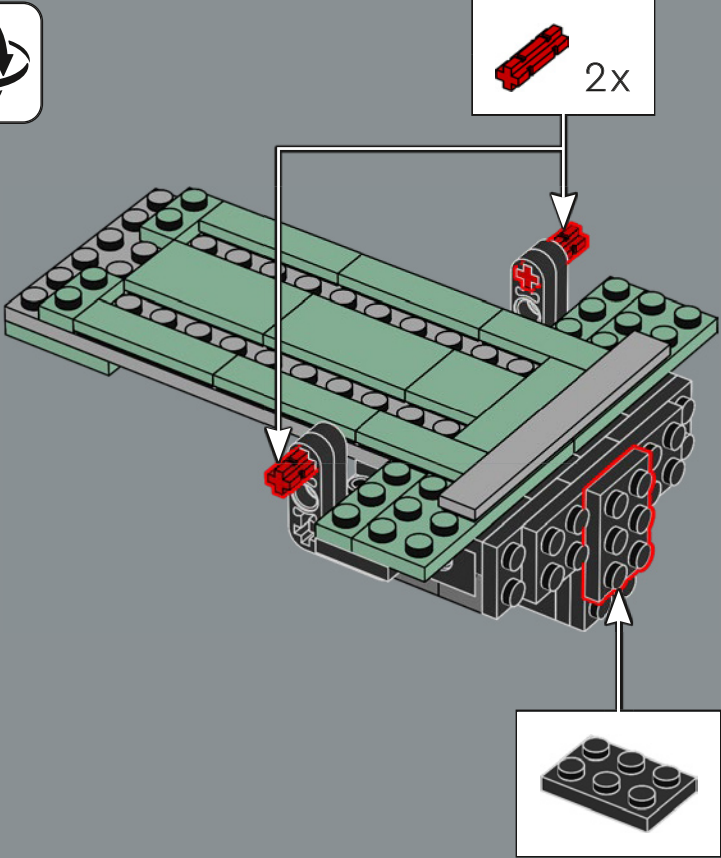



74

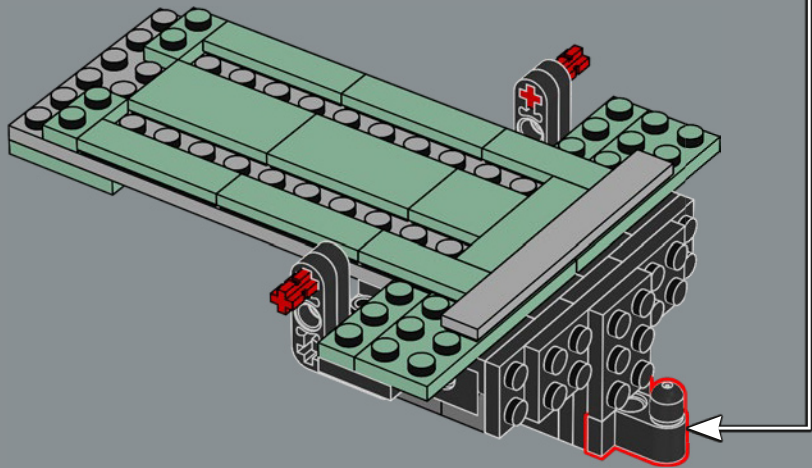
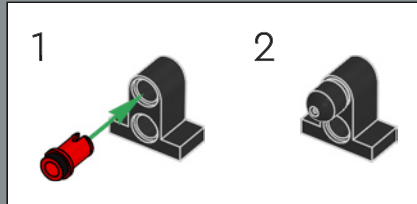

75

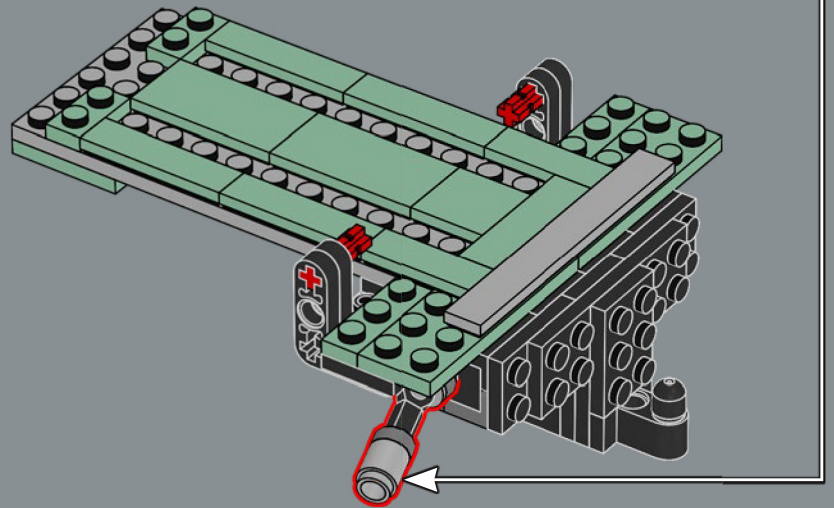
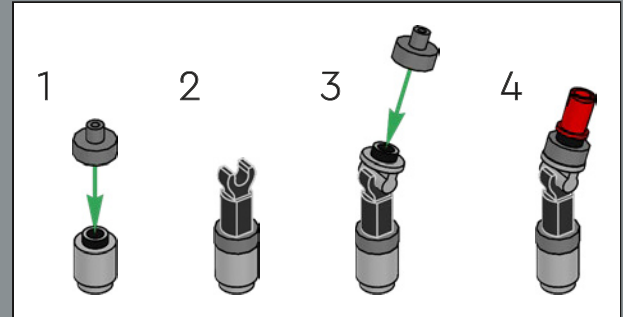

76

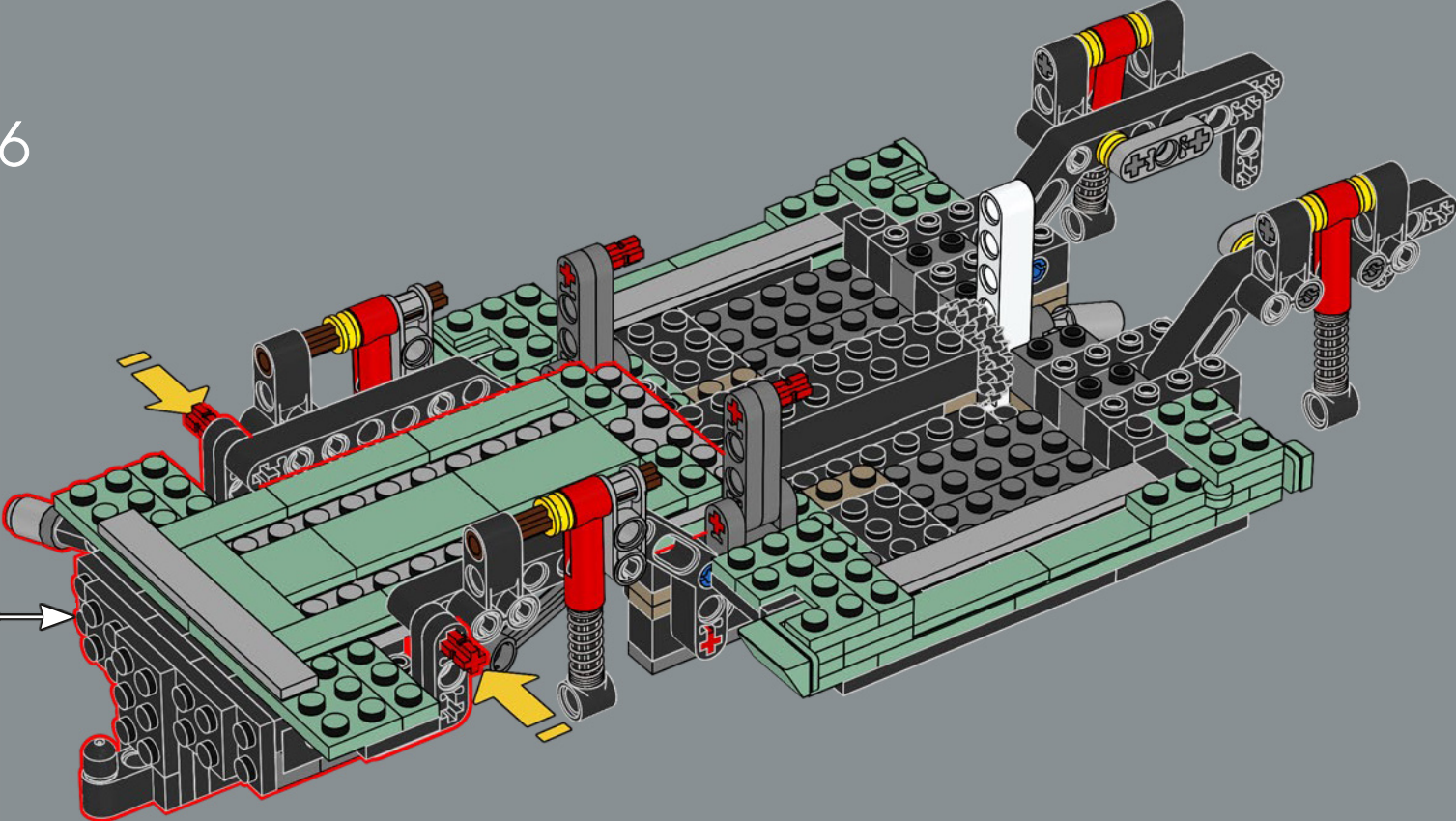

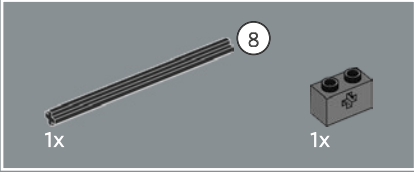
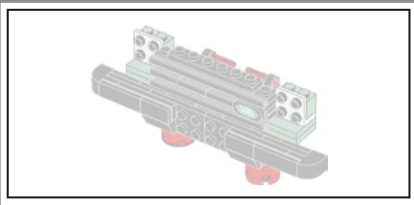

77

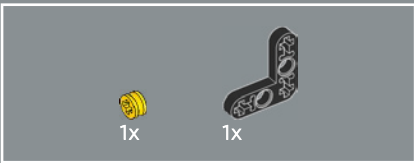
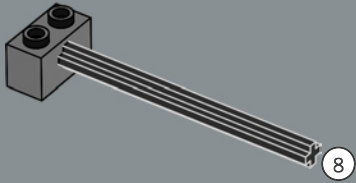

78

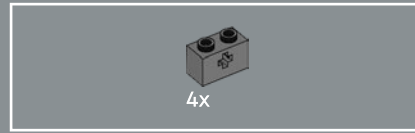
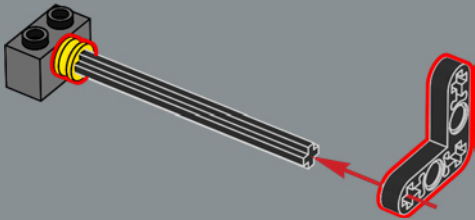

79

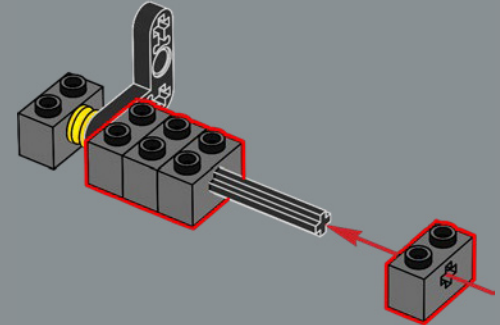

80

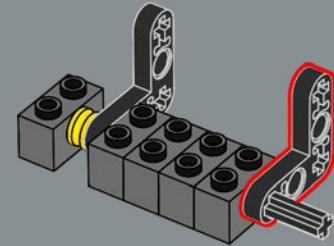



81

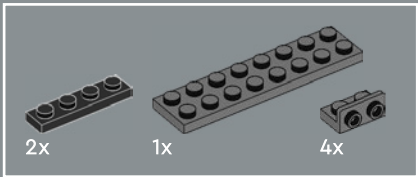
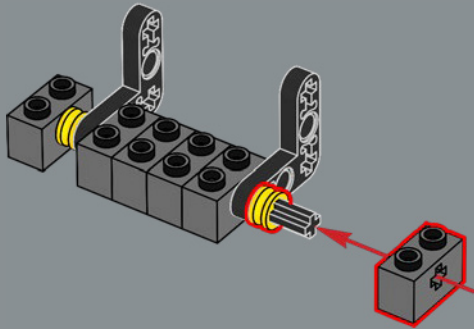

82

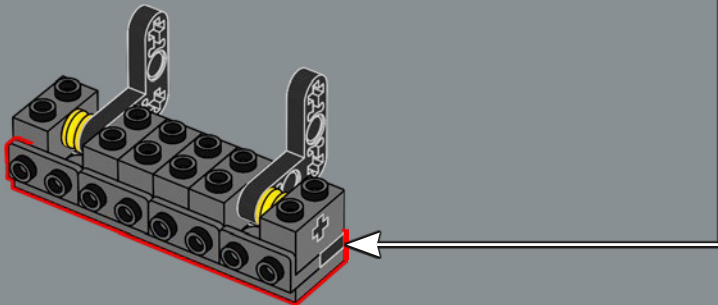
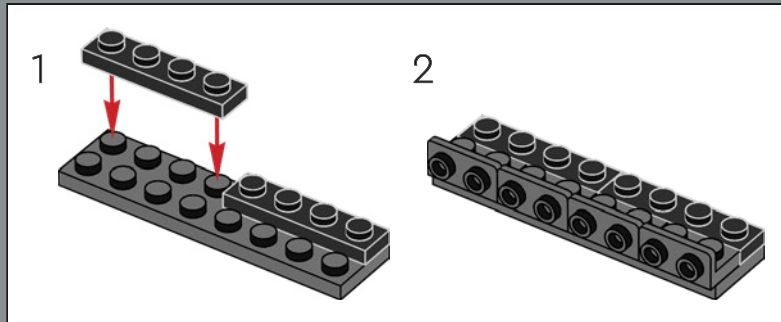

83

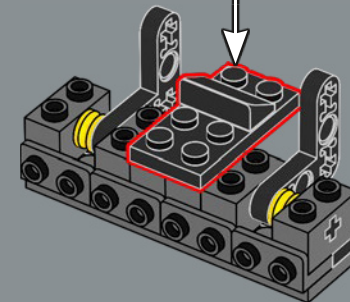
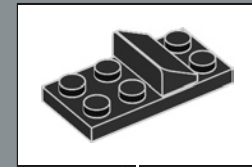

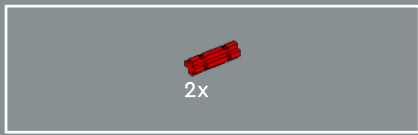

84

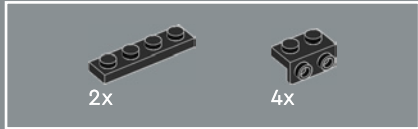
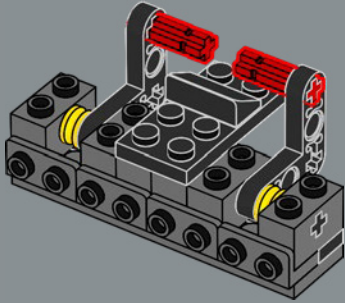

85

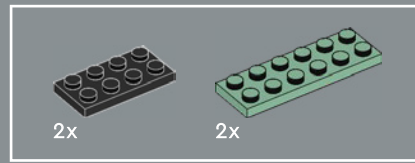
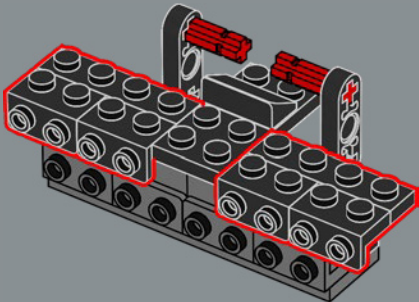

86

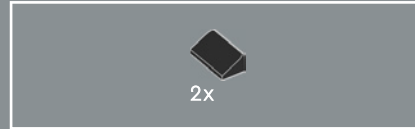
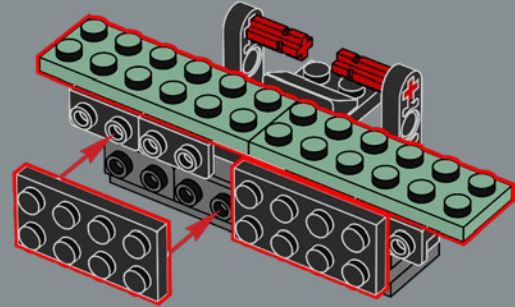

87

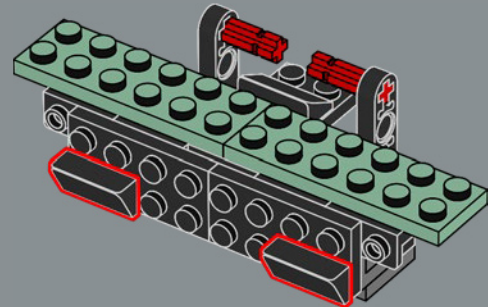

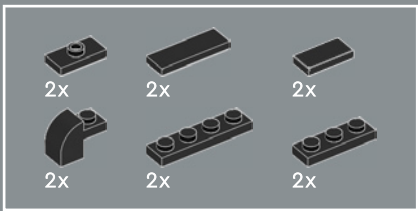

88

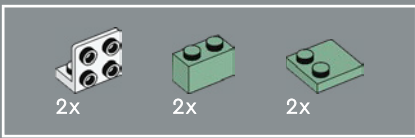
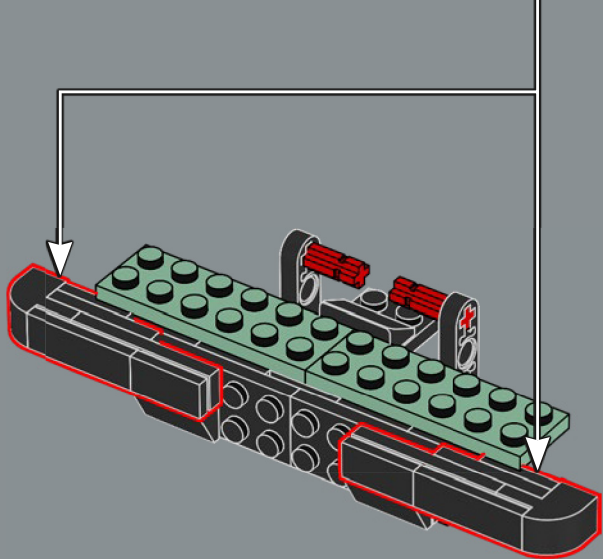
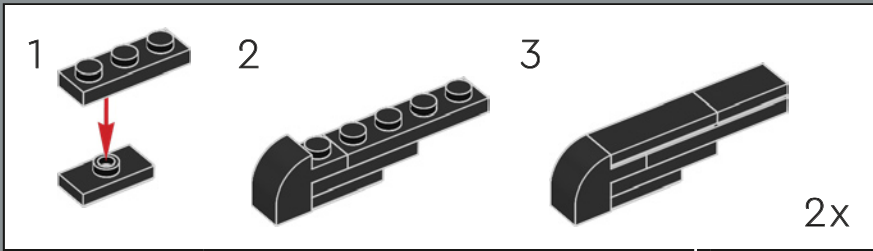

89

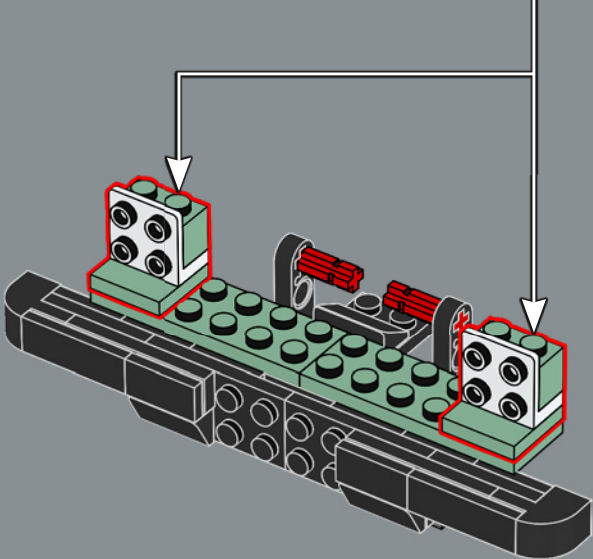
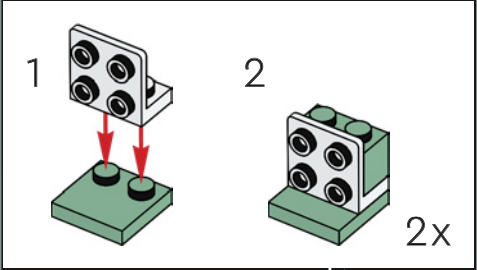

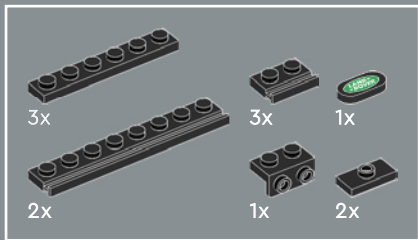

90

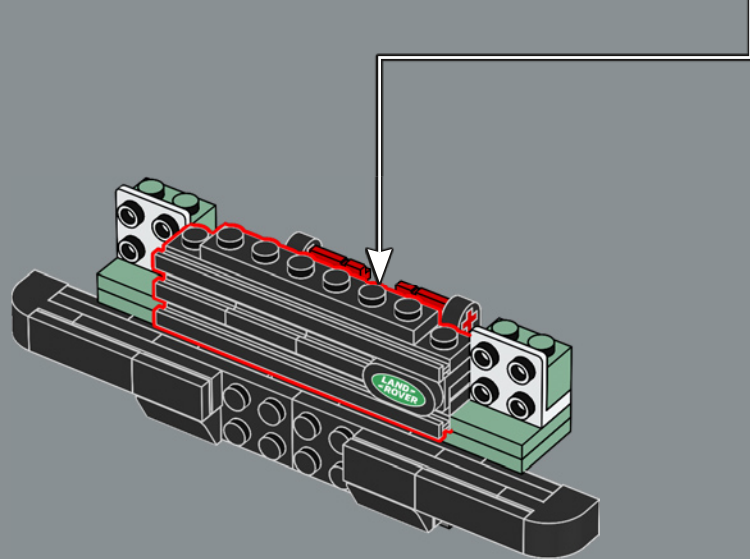
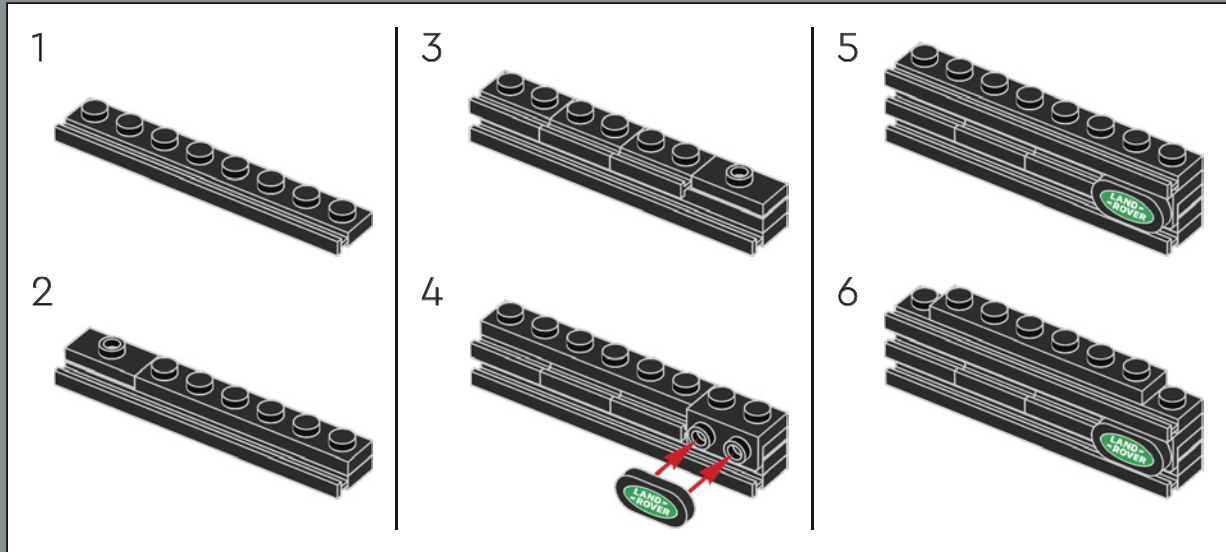



91

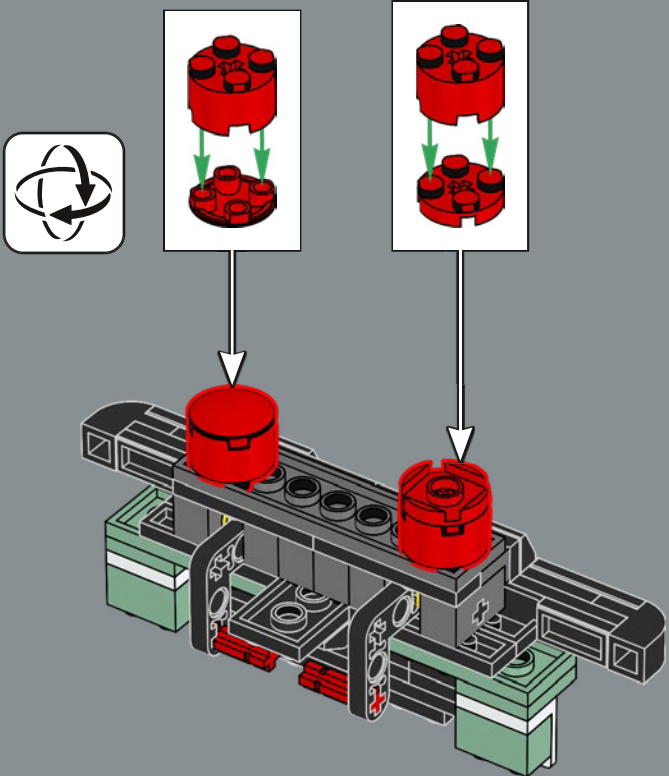

92

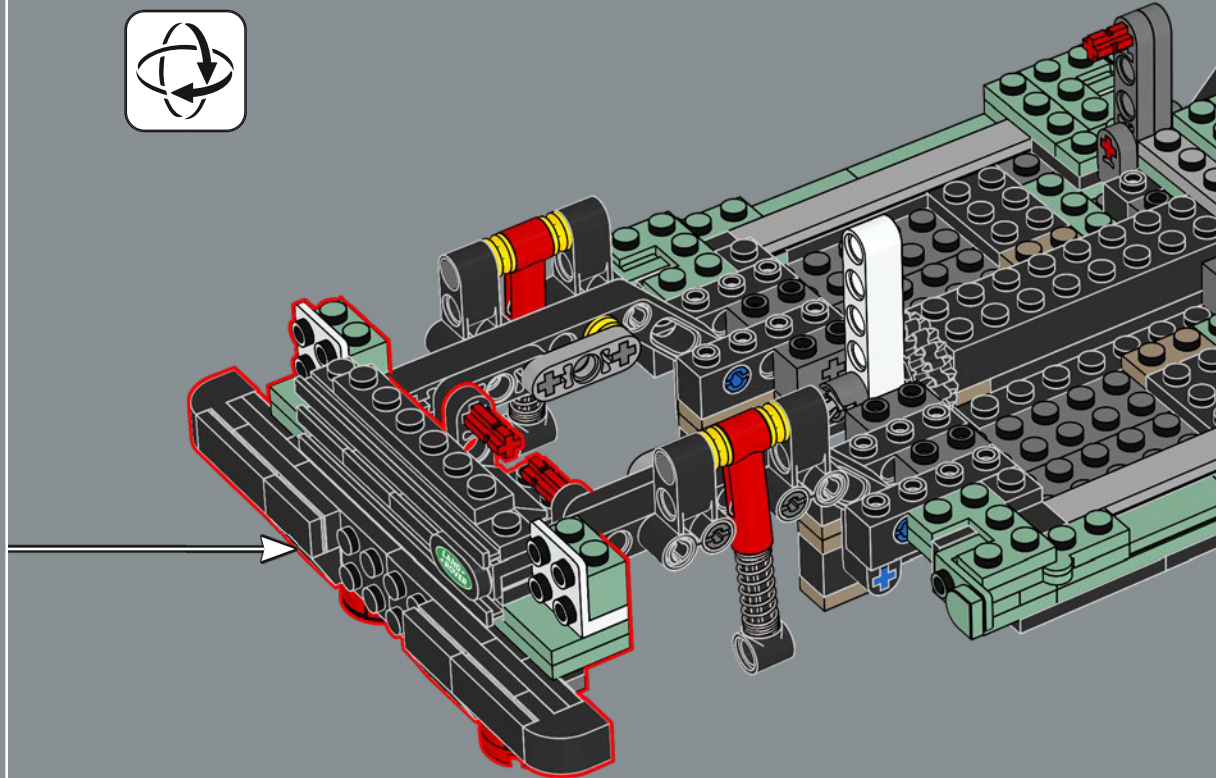

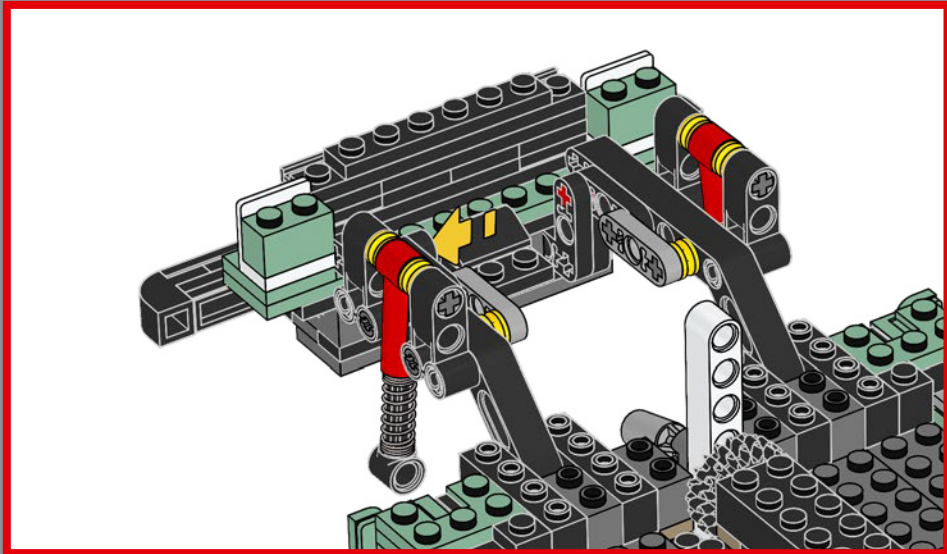
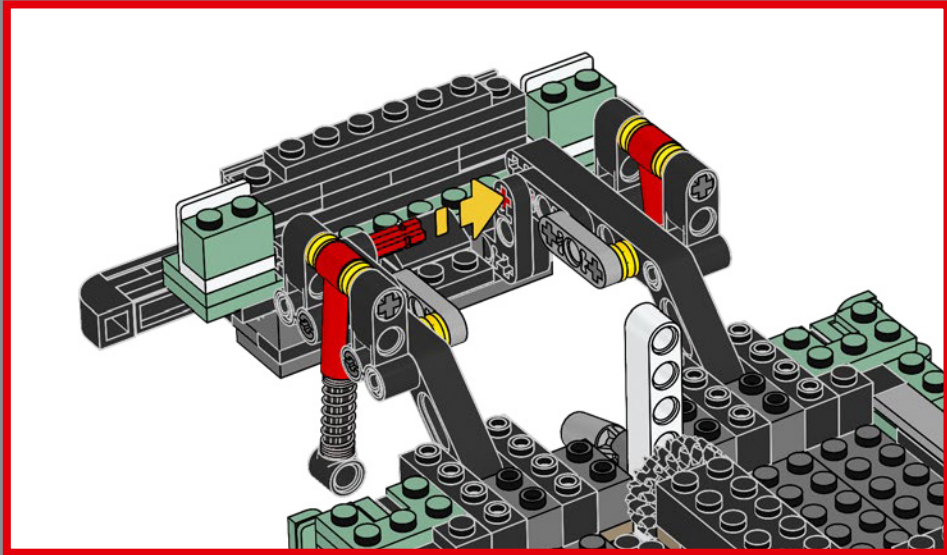



93

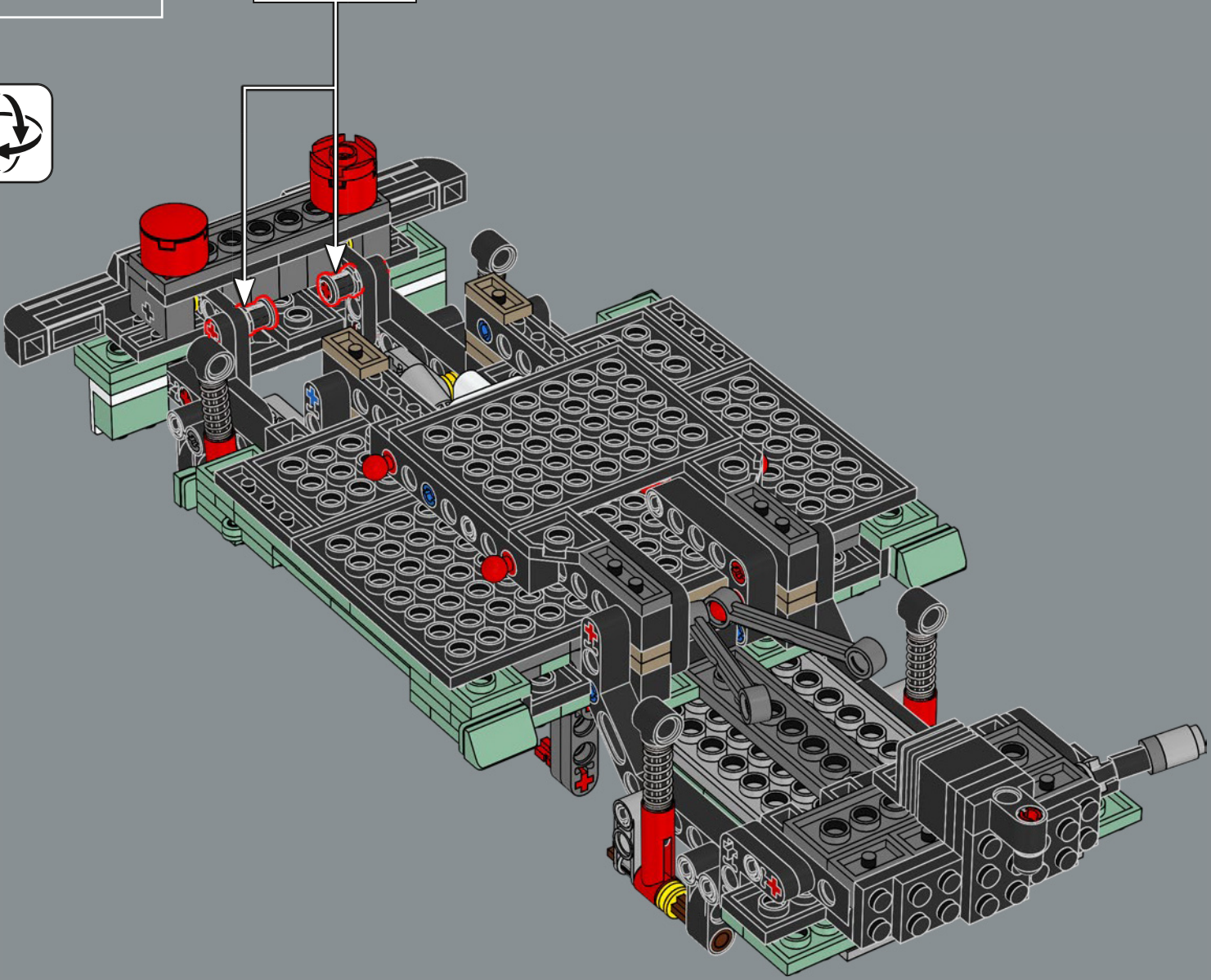

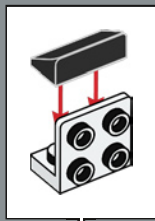
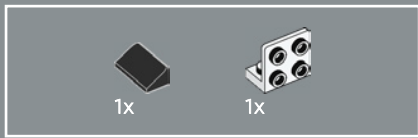

94

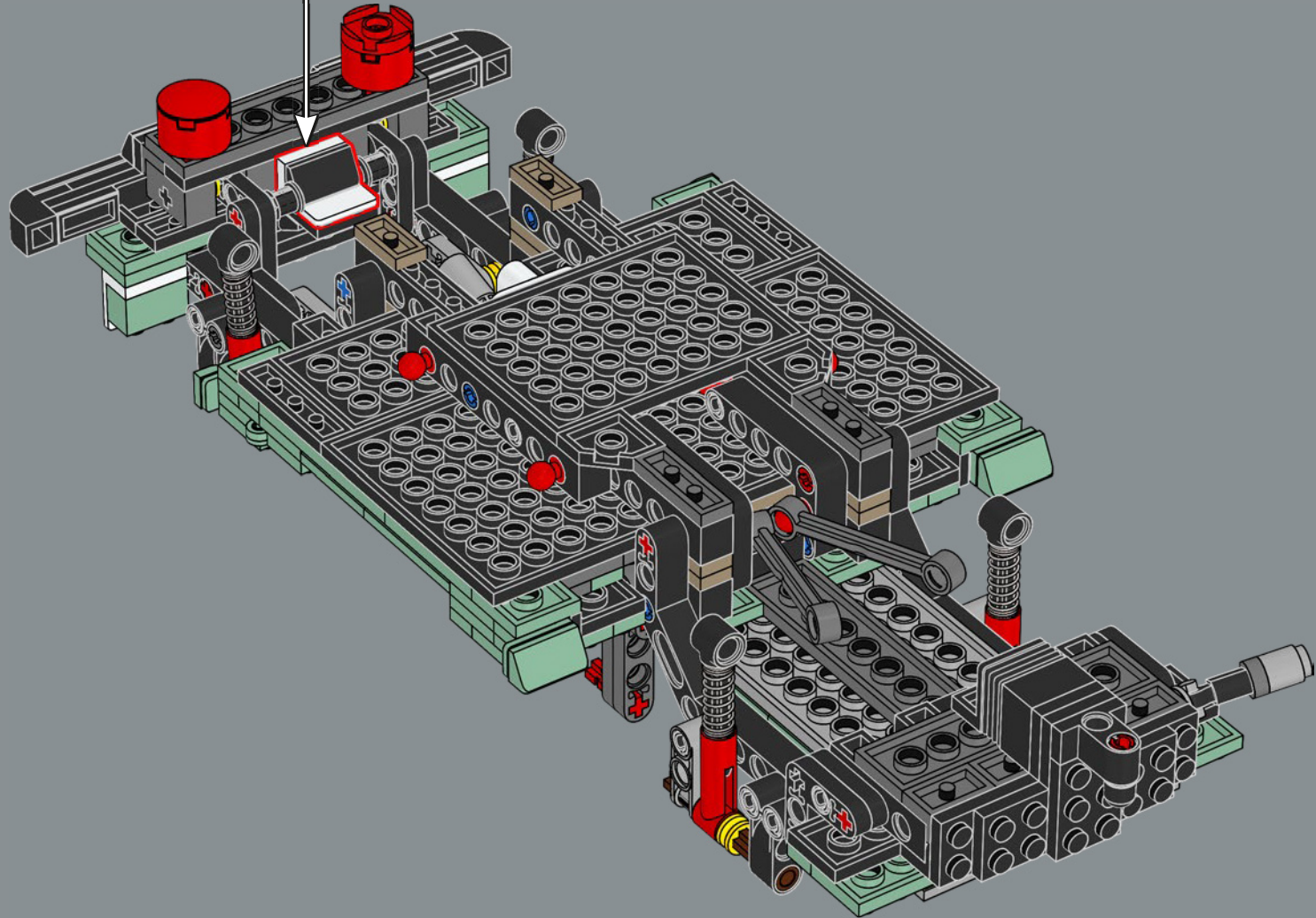

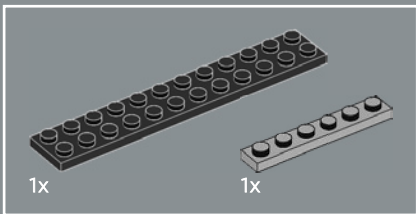
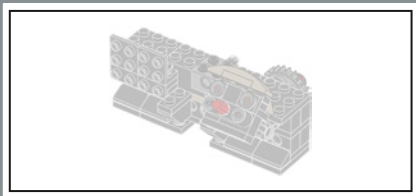

95

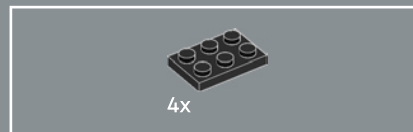
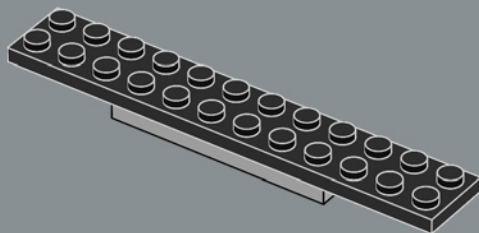

96

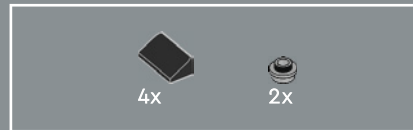
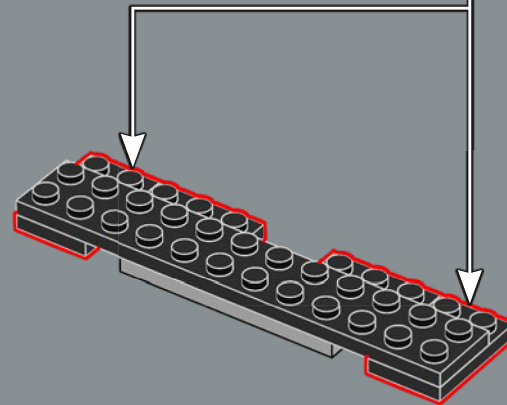
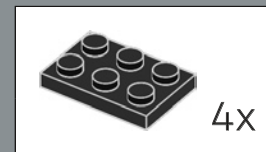

97

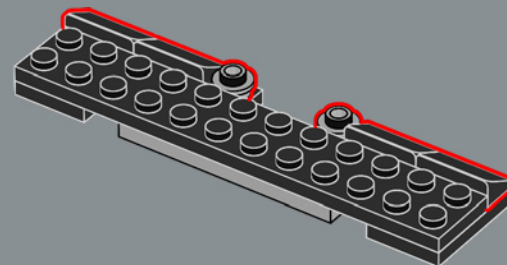

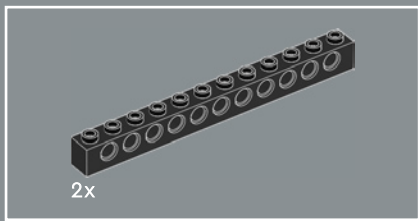

98

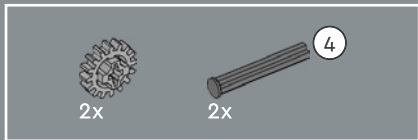
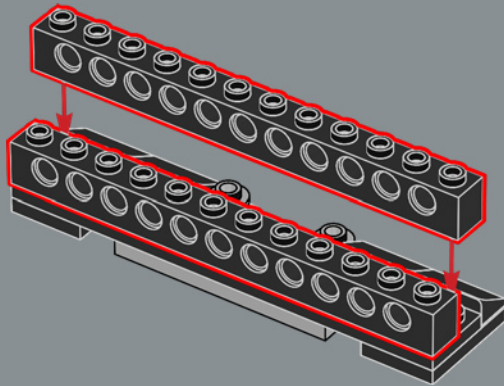

99

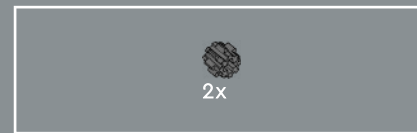
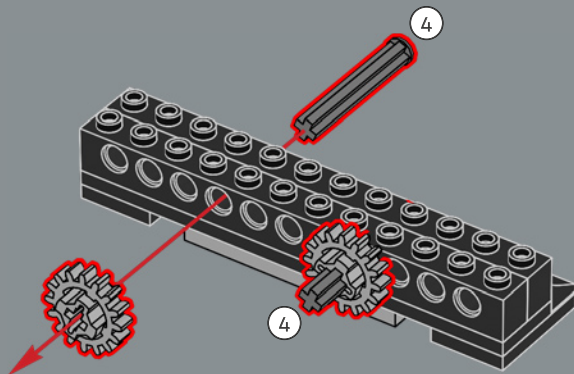

100

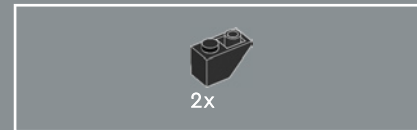
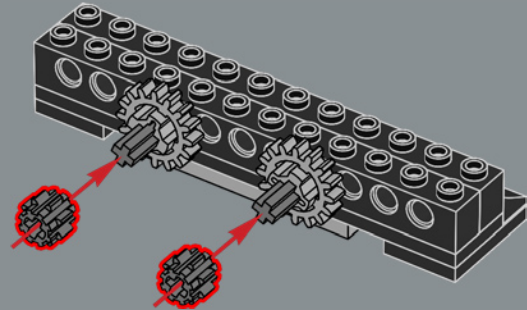

101

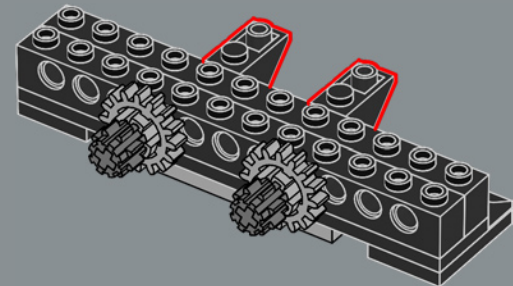

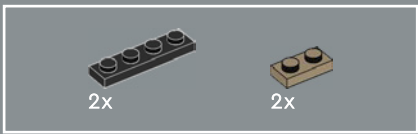

You can place the steering wheel on both sides of the cabin to suit your driving needs for left- or right-hand traffic.

Vous pouvez placer le volant de l'un ou l'autre côté de l'habitacle pour adapter la conduite à la circulation sur la voie de gauche ou de droite.

Puedes colocar el volante en ambos lados de la cabina para adaptar el vehículo según tu necesidad de conducción, ya sea por la izquierda o por la derecha.

102

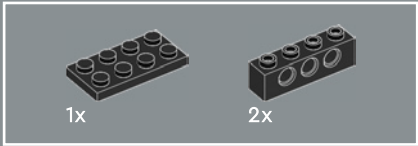
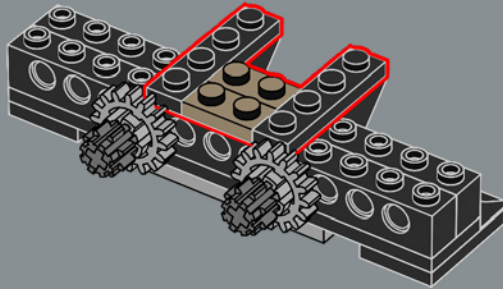

103

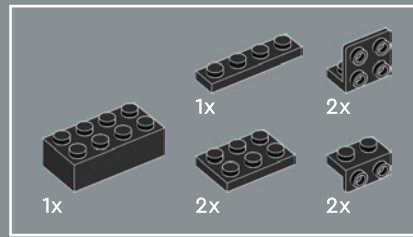
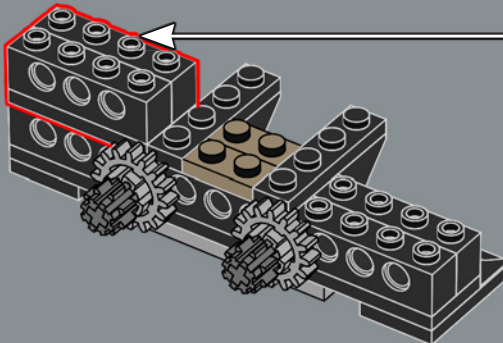
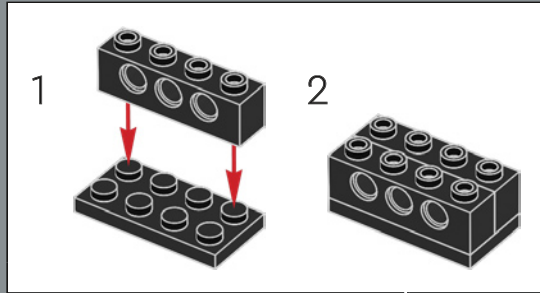

104

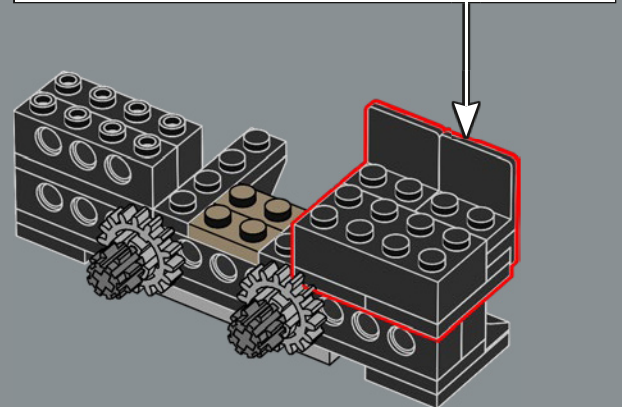
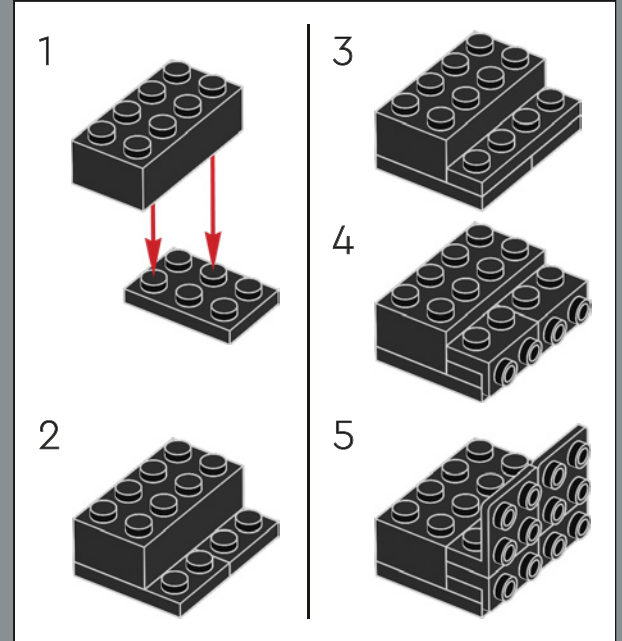

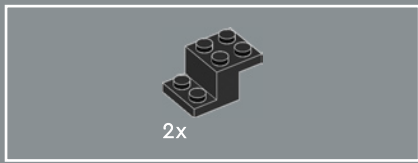

105

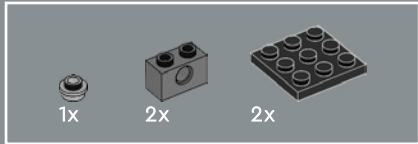
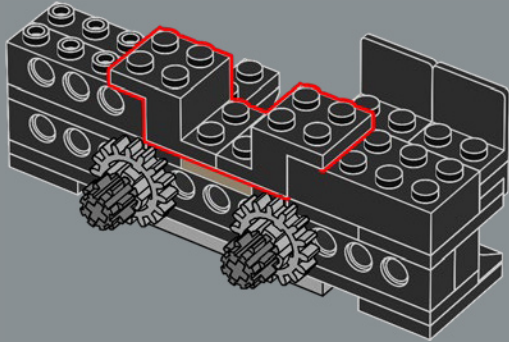

106

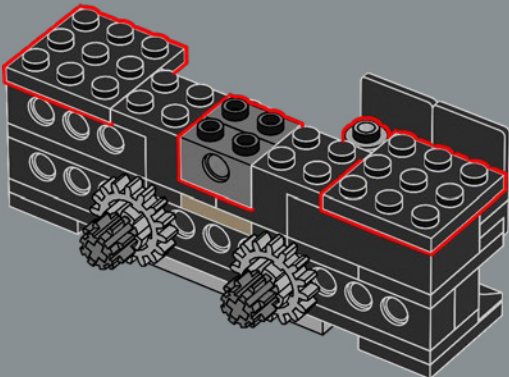

107

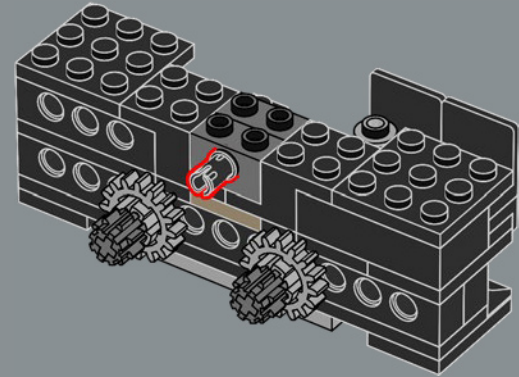

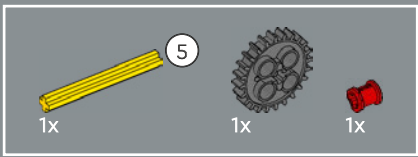

108

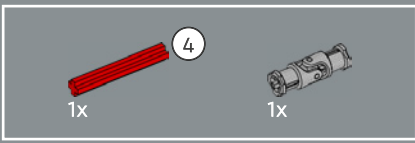
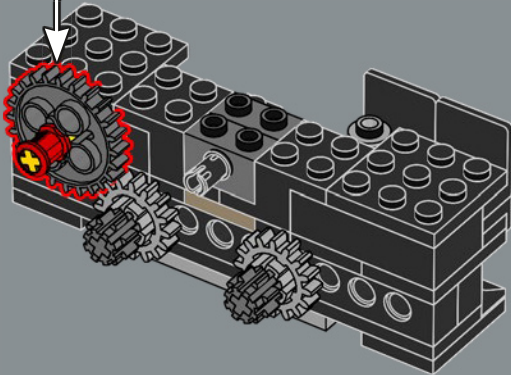
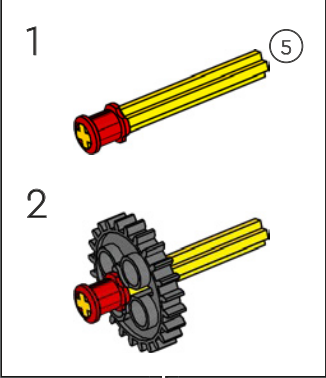

109

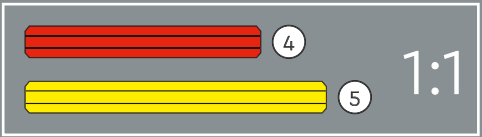
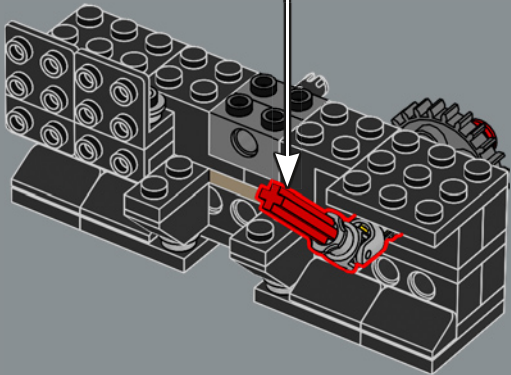
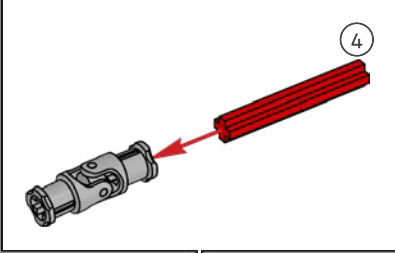

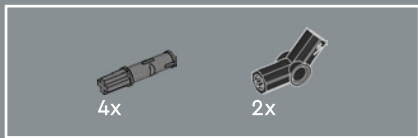

110

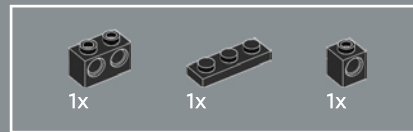
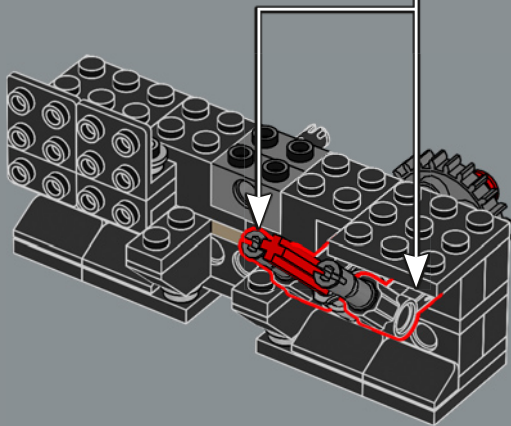
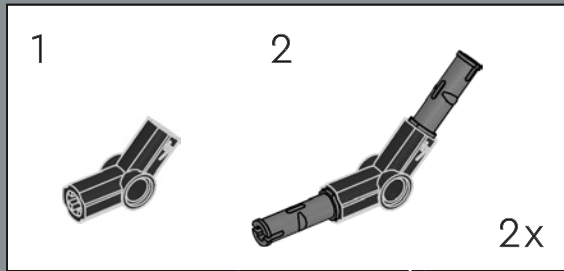

111

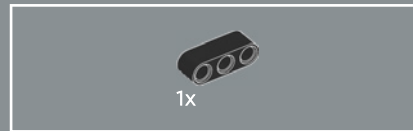
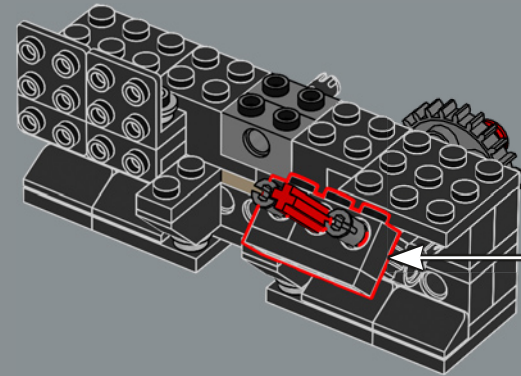
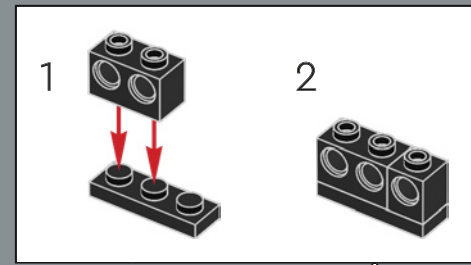

112

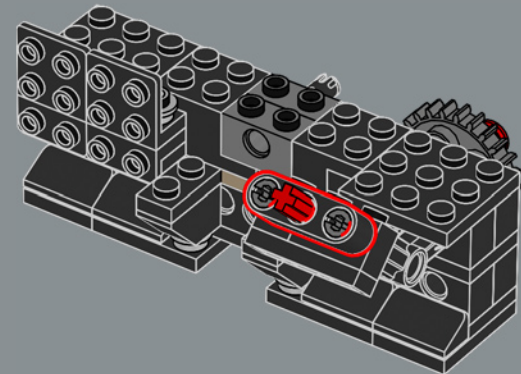

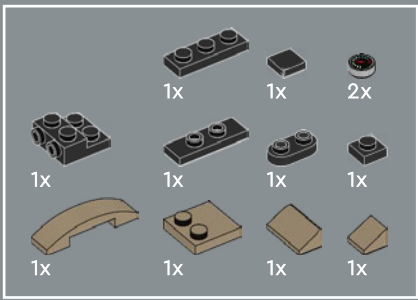

113

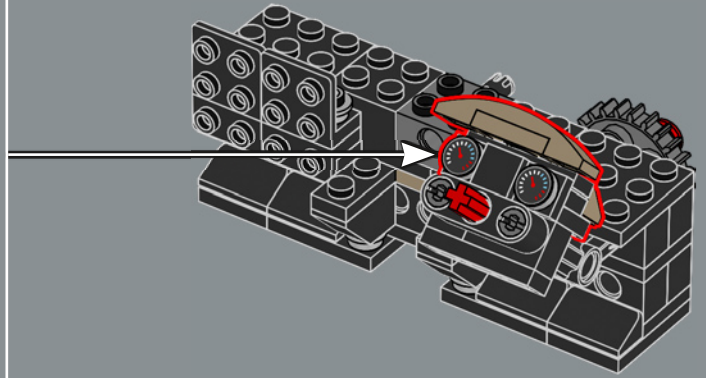
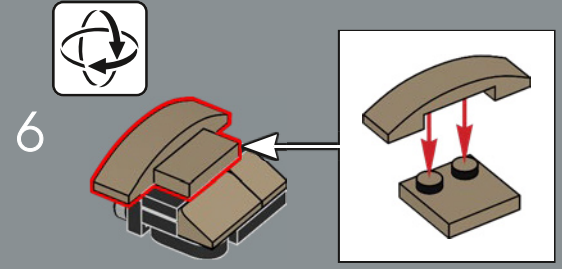
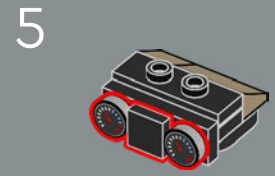
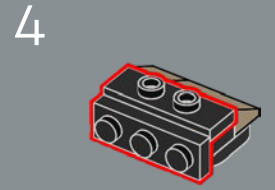
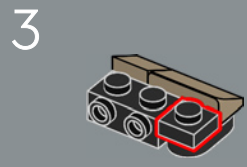
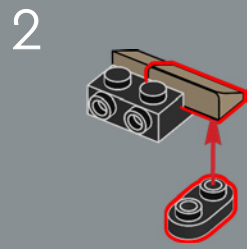
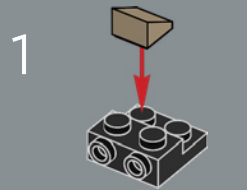

114

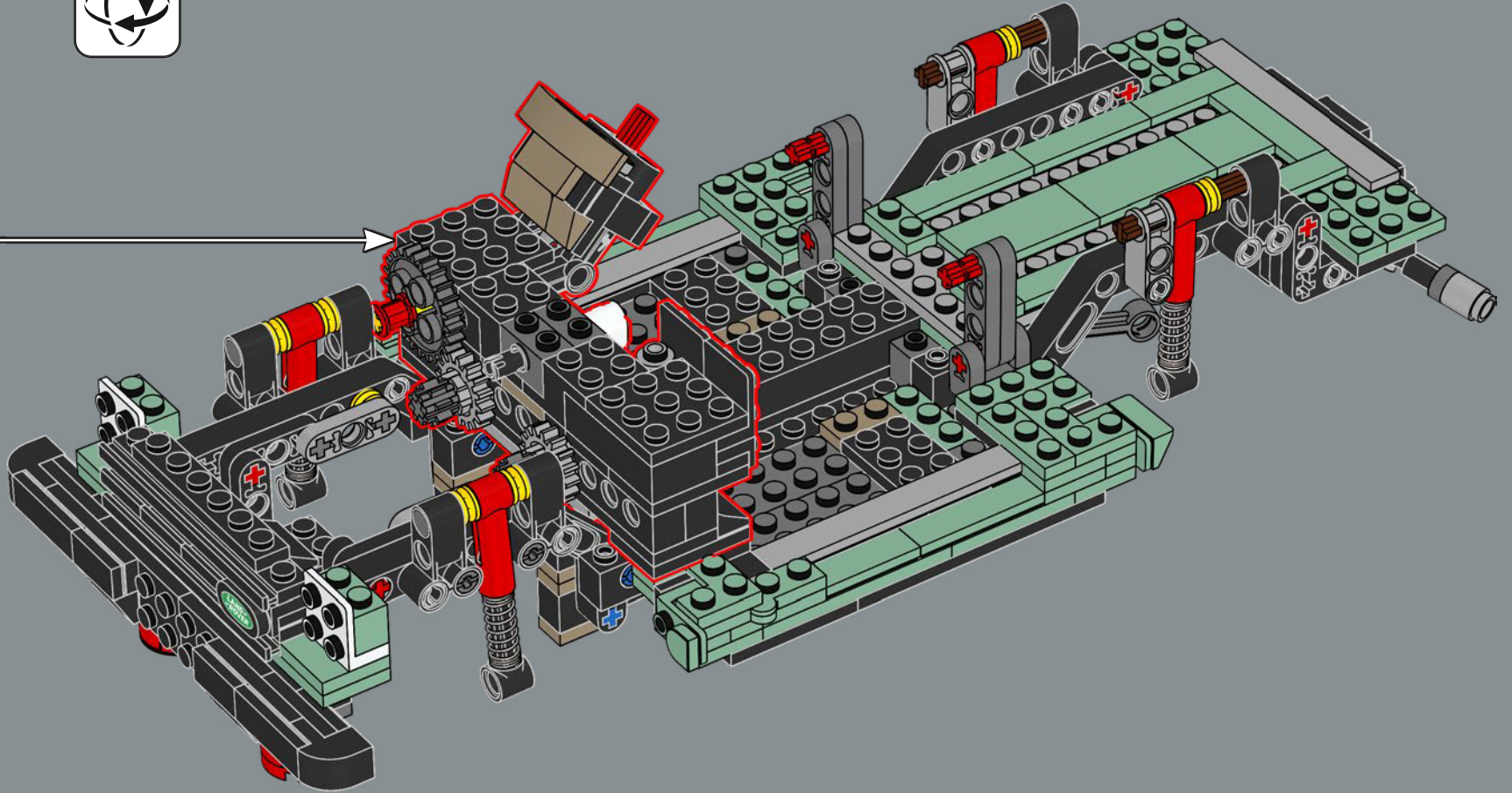



115

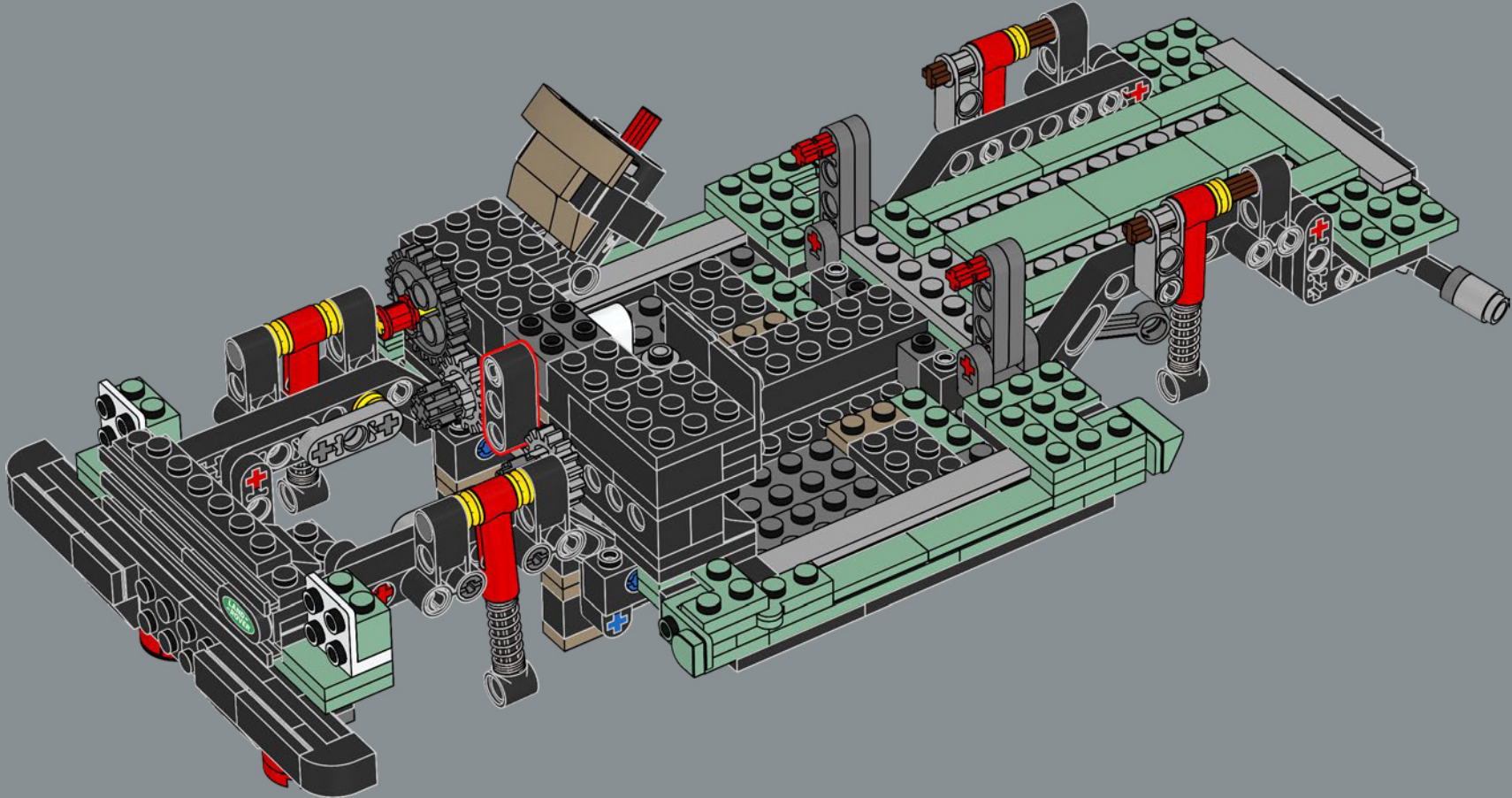

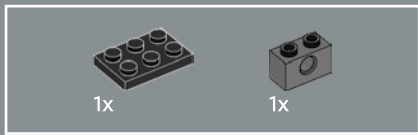

116

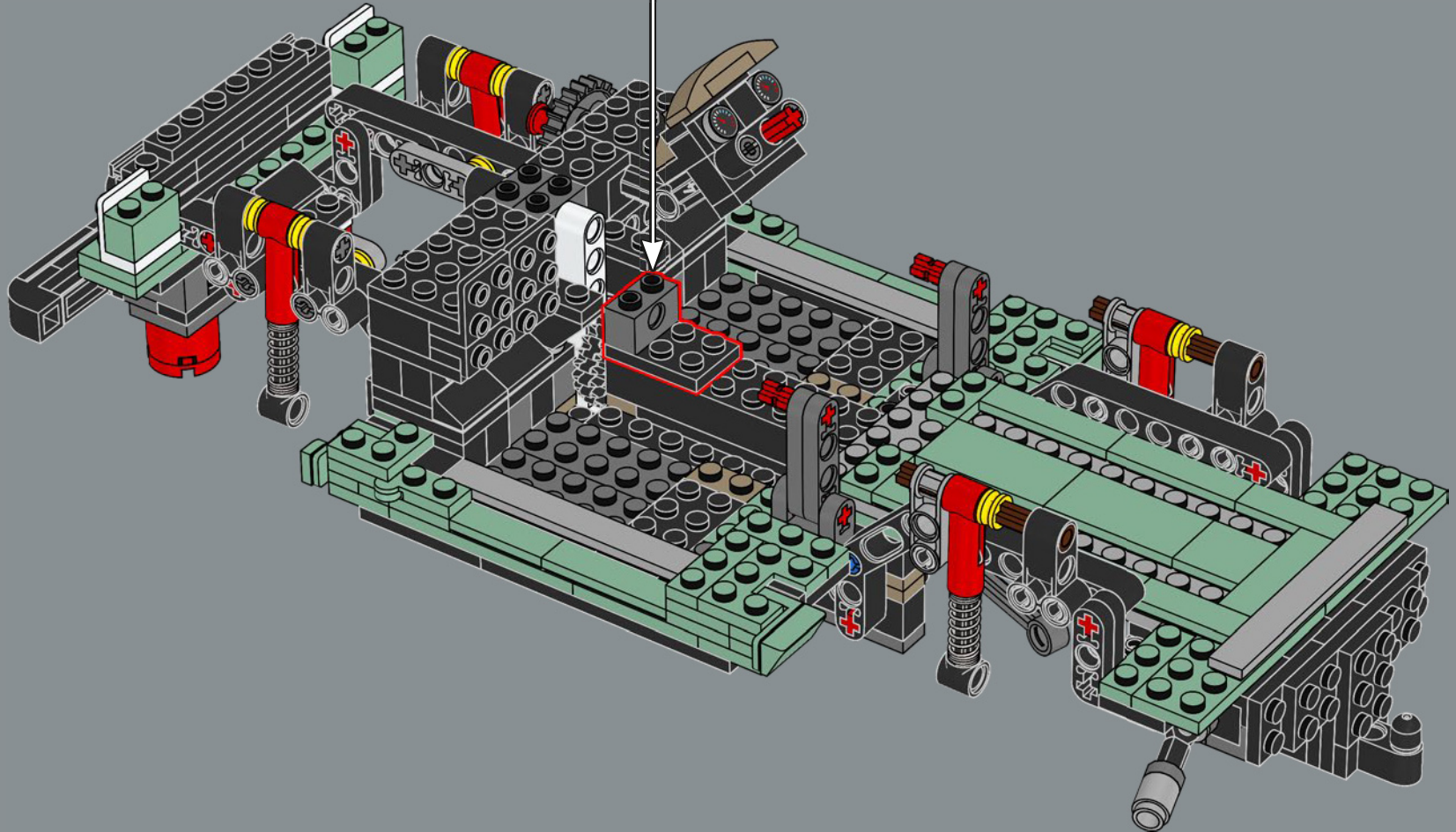
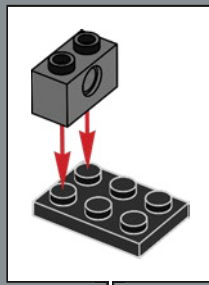

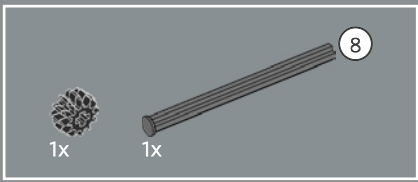

117

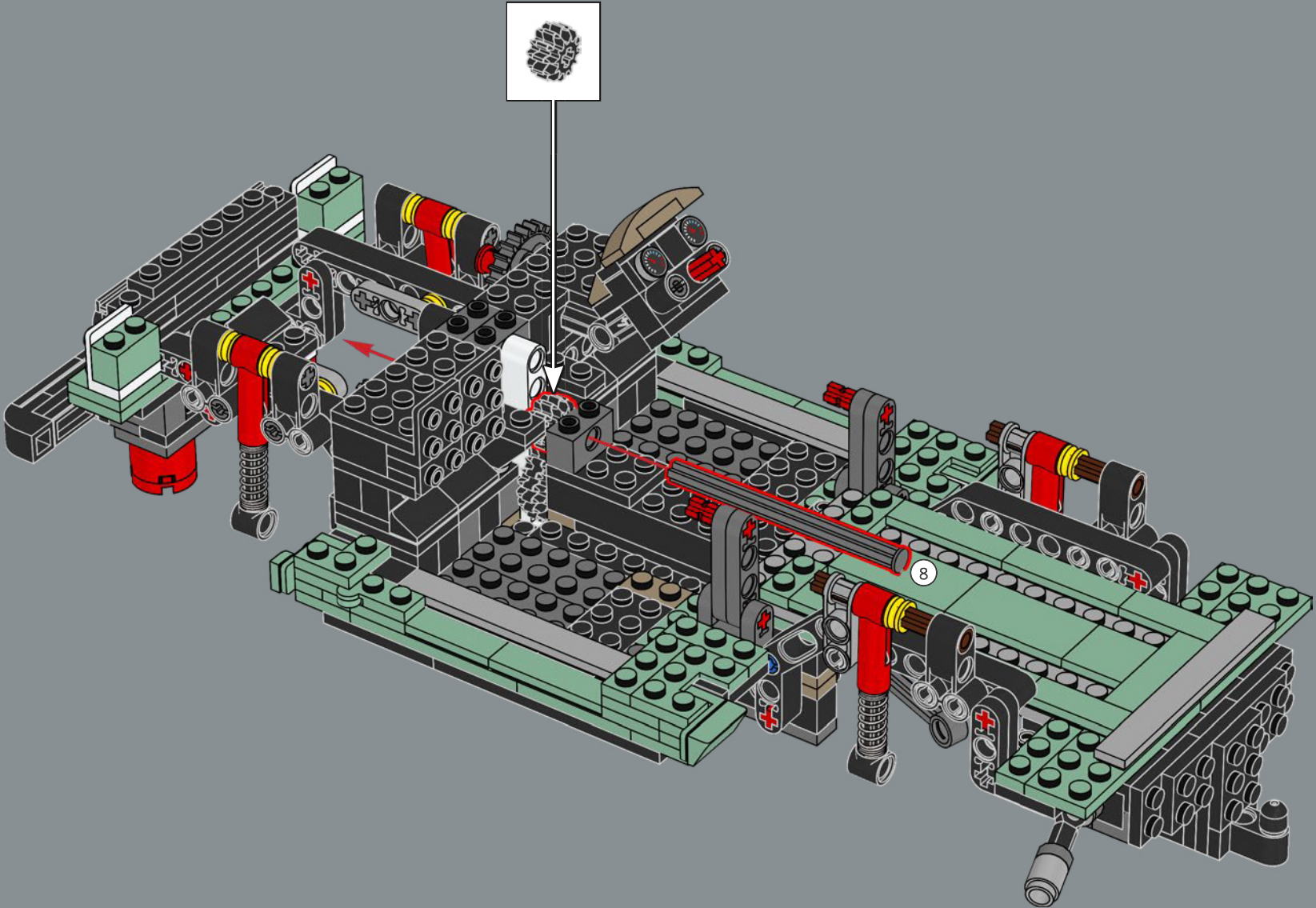

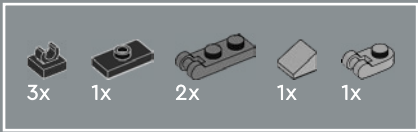

118

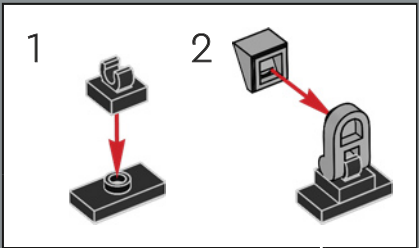
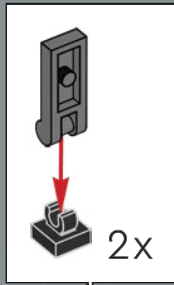
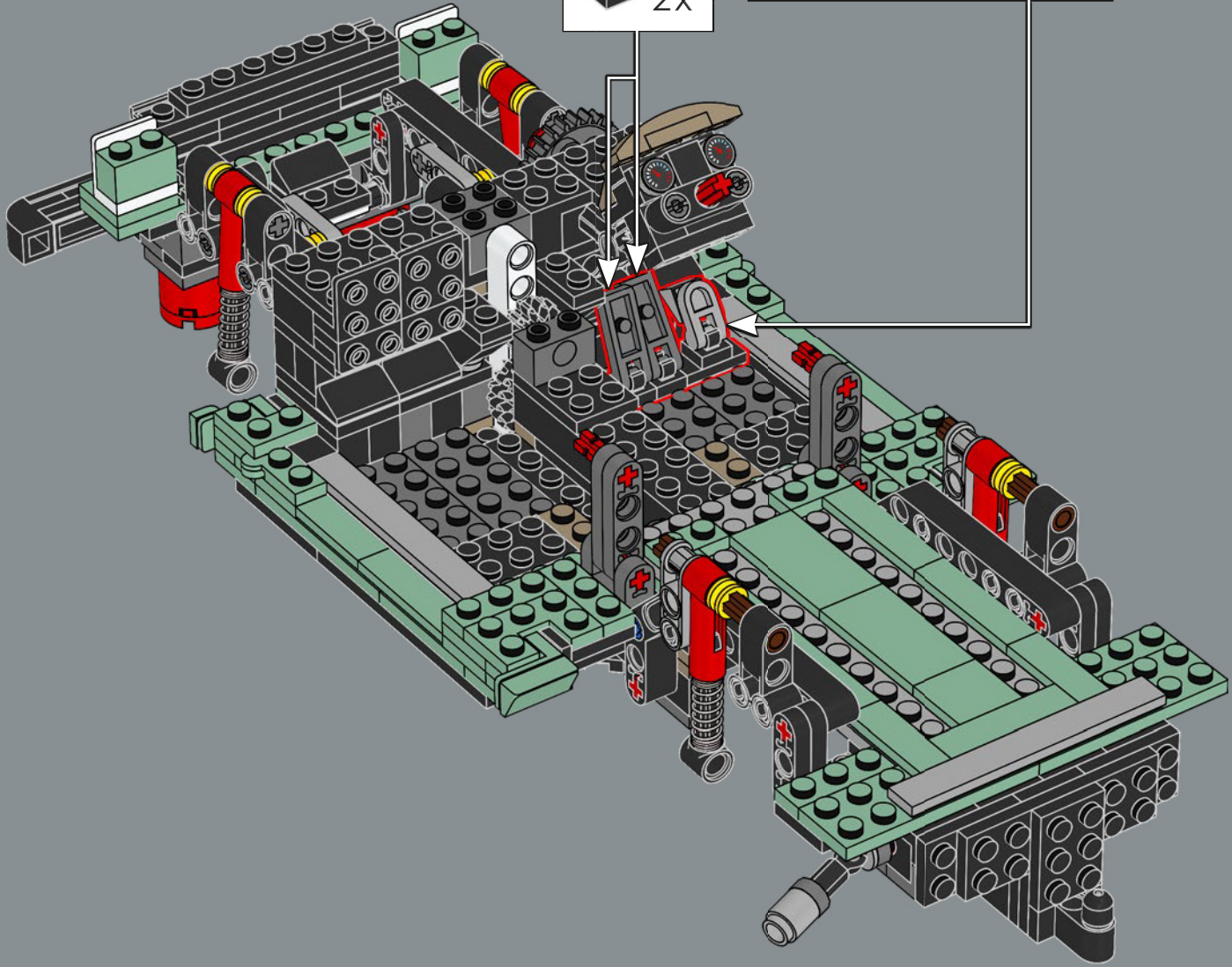

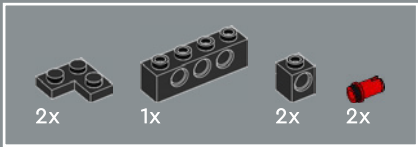

119

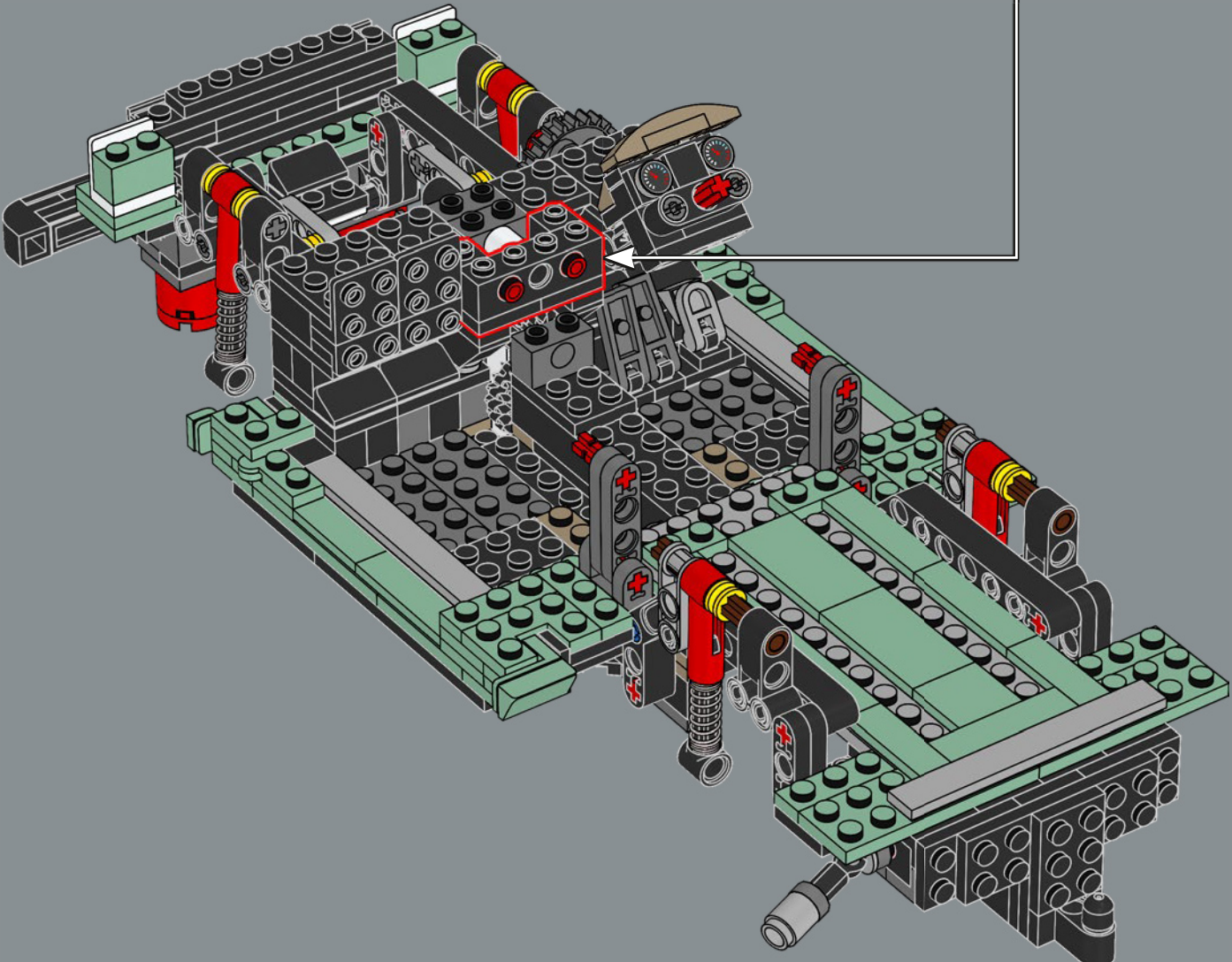
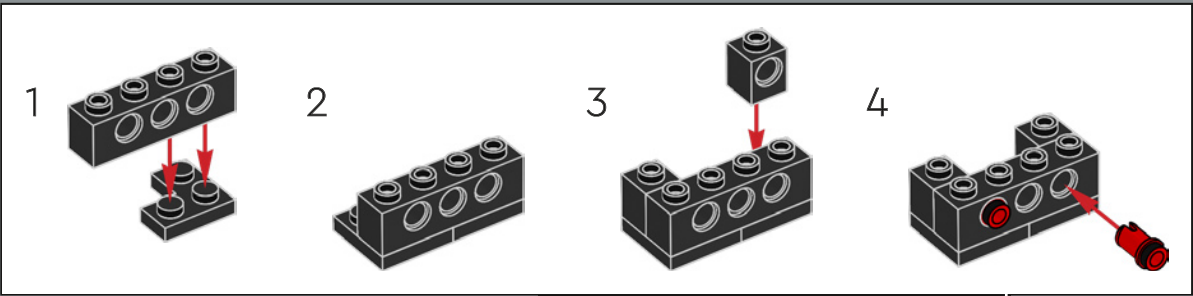

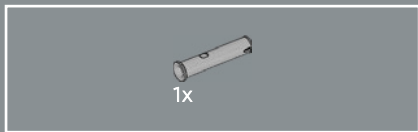

120

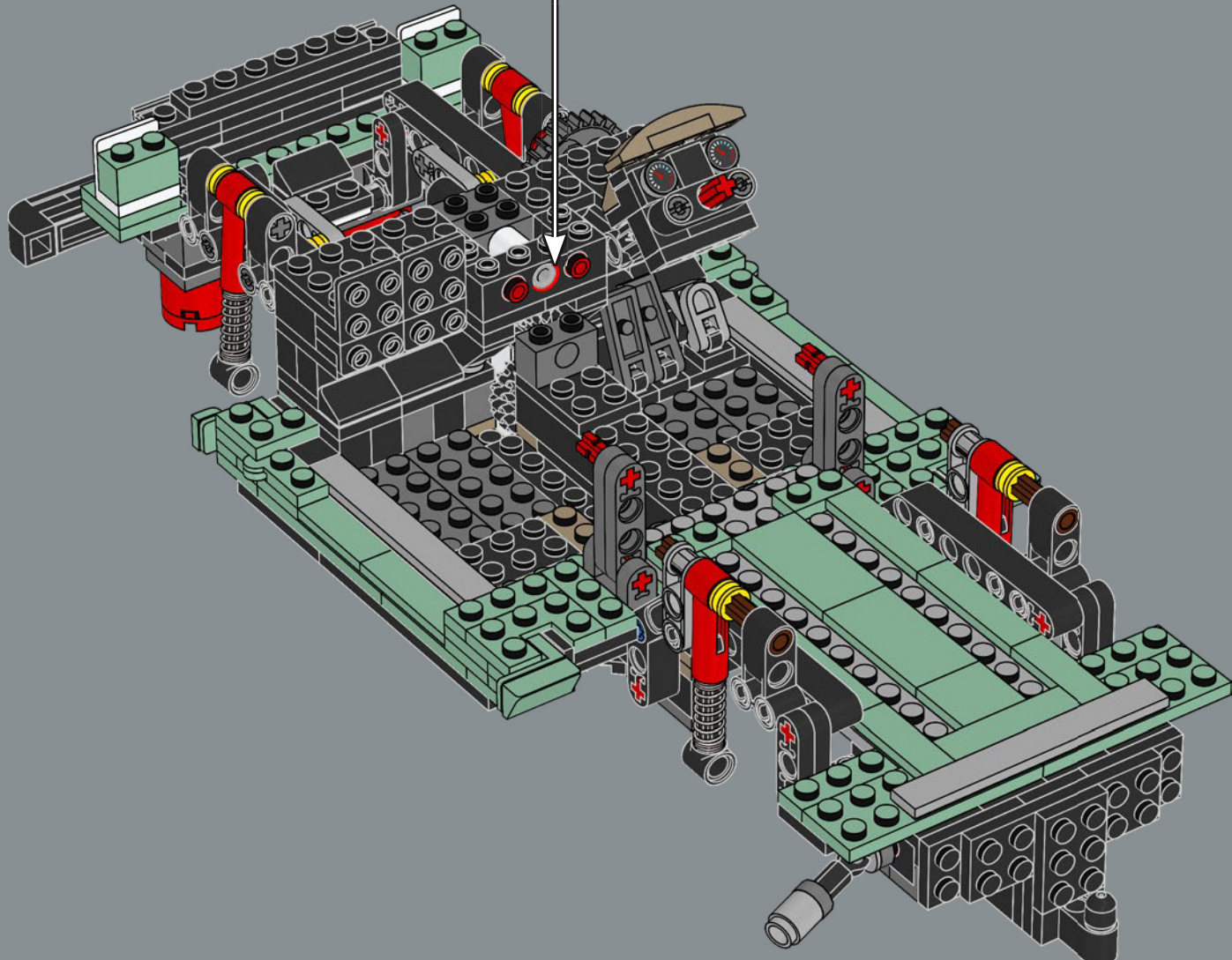
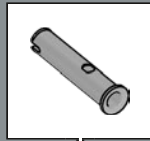

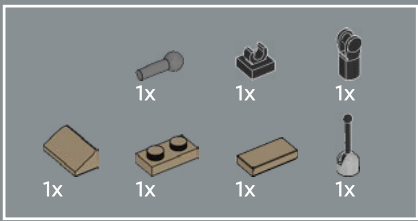

121

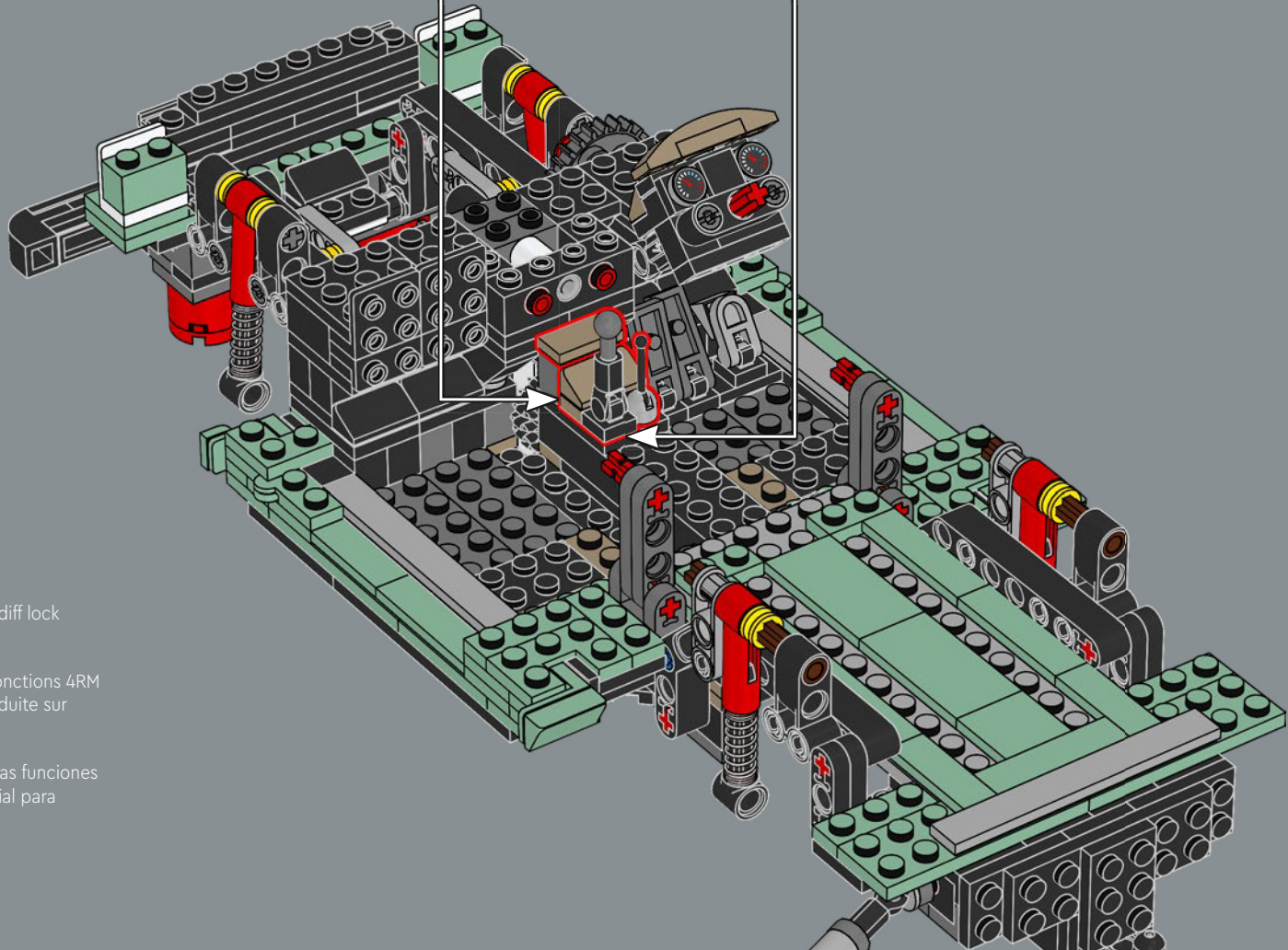
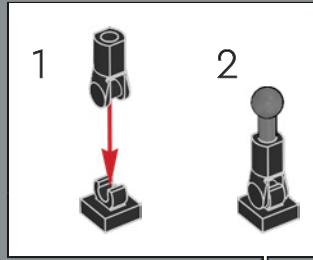
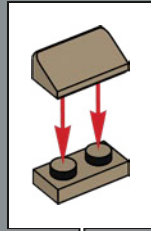

The second gear stick mimics 4WD and diff lock functions for your rough terrain driving.

Le deuxième levier de vitesse imite les fonctions 4RM et de blocage du différentiel pour la conduite sur terrain accidenté.

La segunda palanca de cambios replica las funciones de doble tracción y bloqueo de diferencial para conducir en terrenos difíciles.

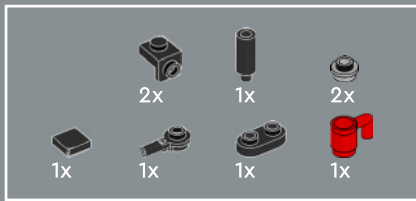

122

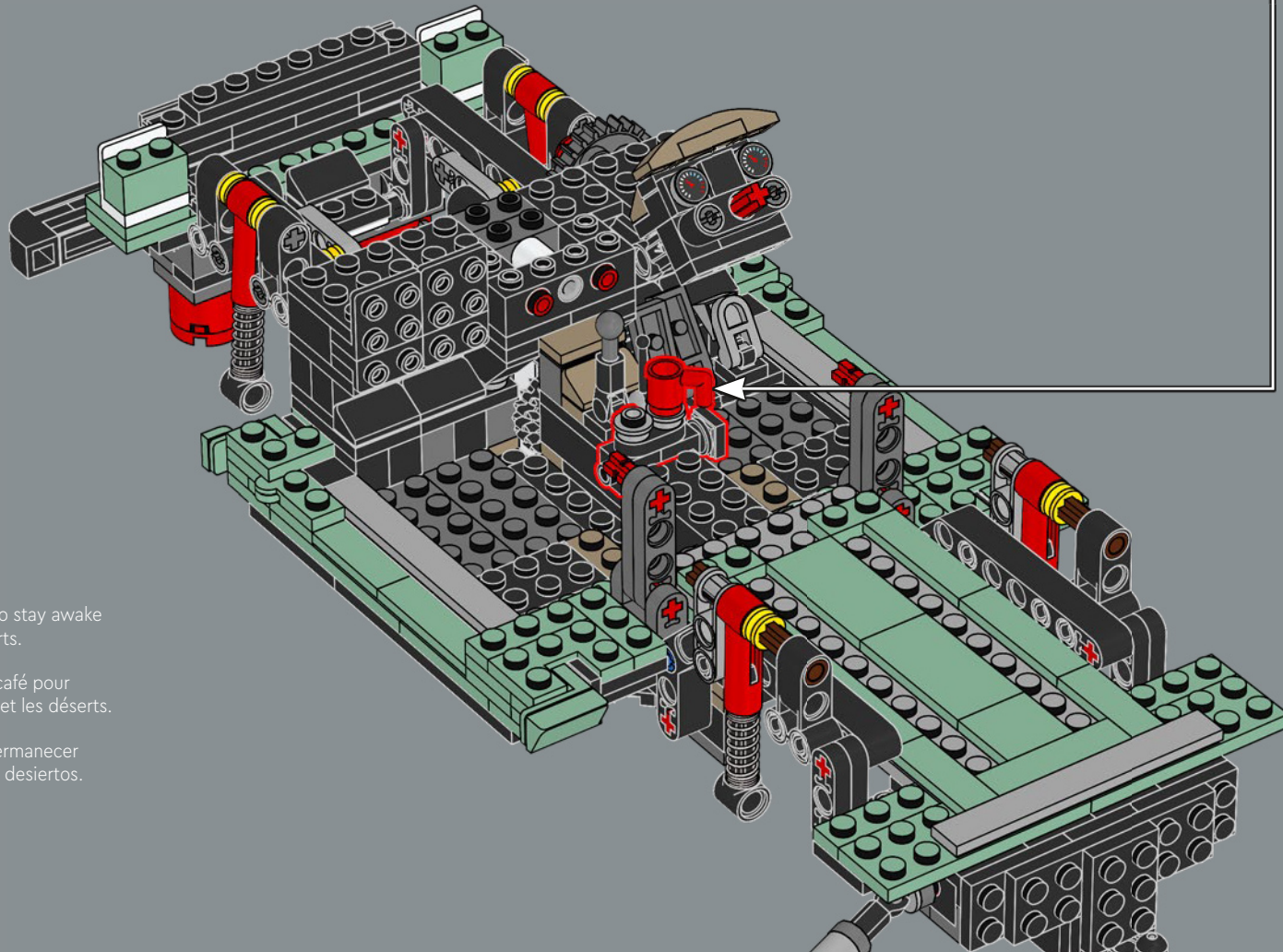
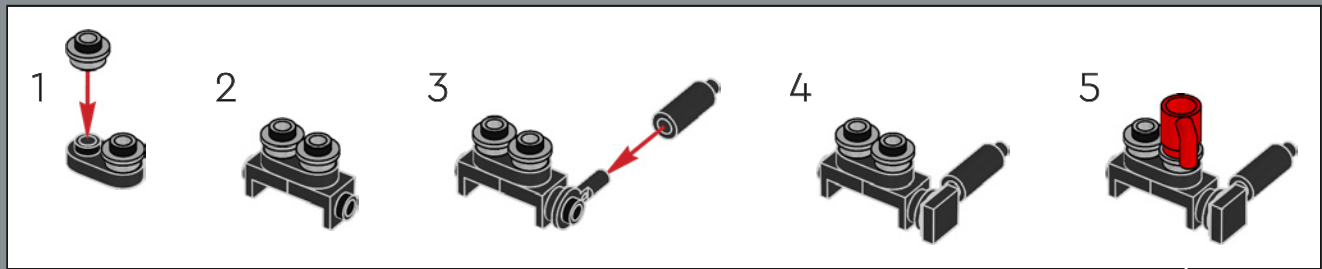

Don't forget to bring coffee to stay awake and alert in jungles and deserts.

N'oubliez pas d'apporter du café pour rester alerte dans les jungles et les déserts.

No olvides llevar café para permanecer despierto y alerta en selvas y desiertos.

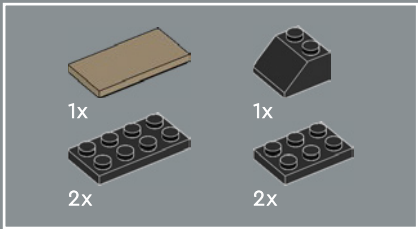

123

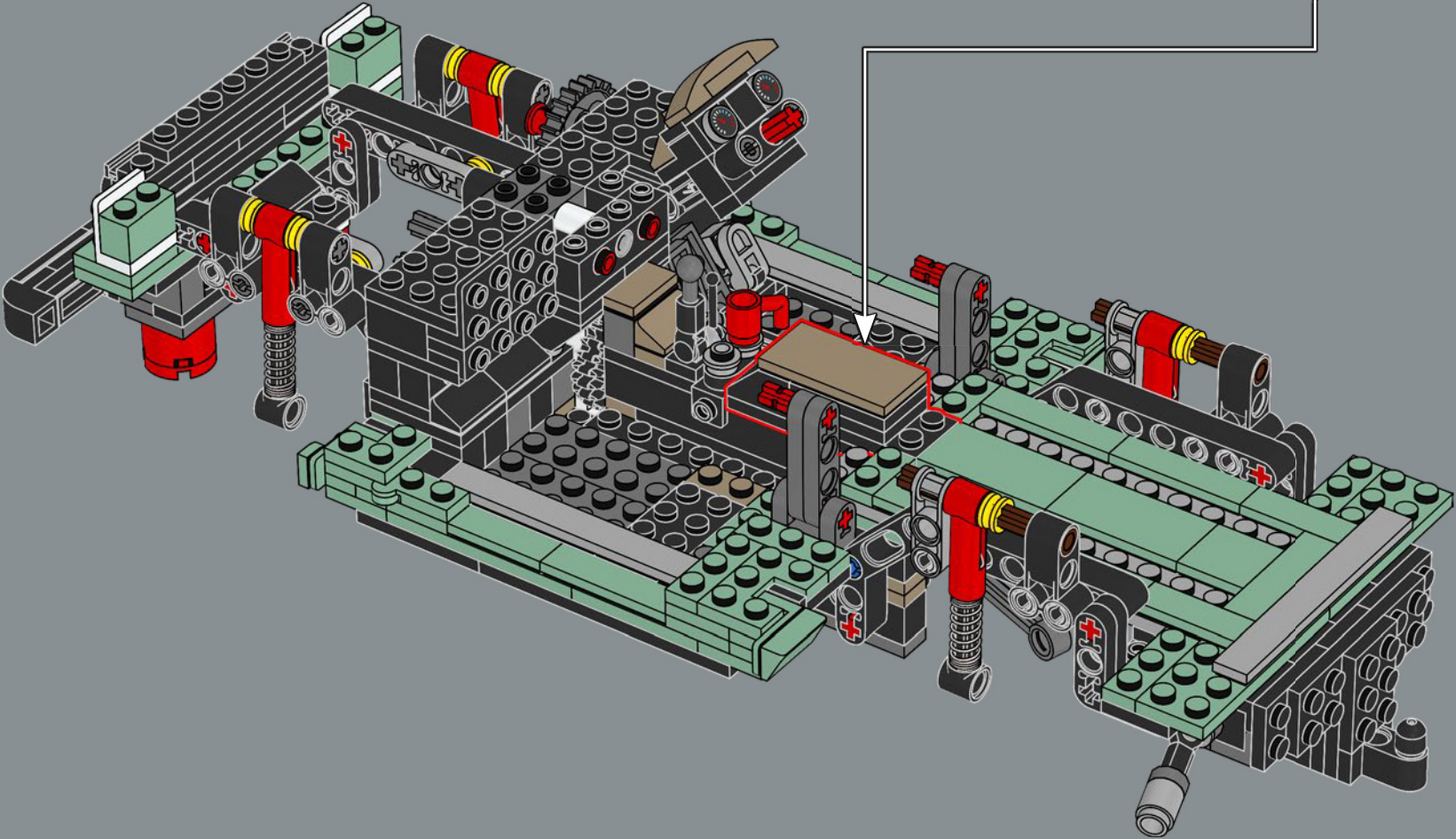
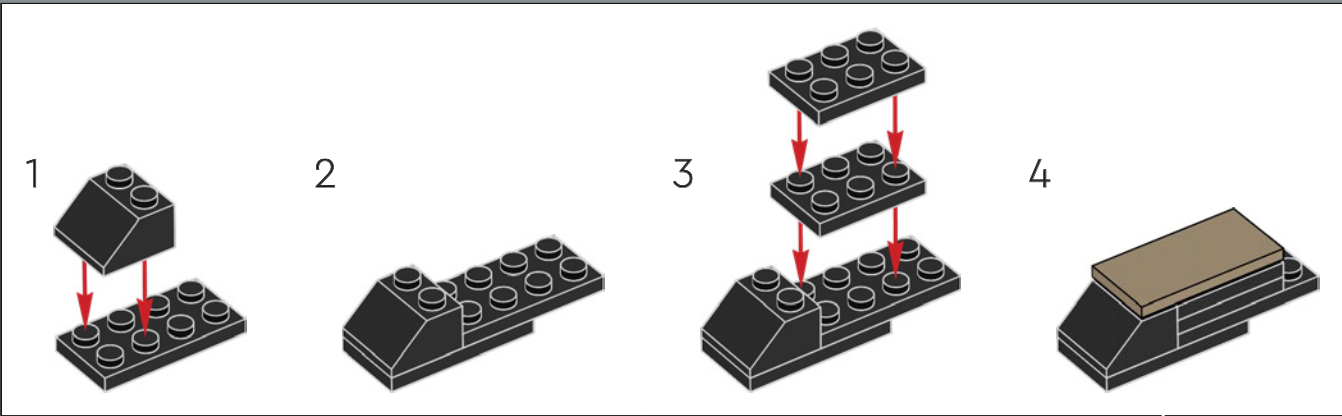

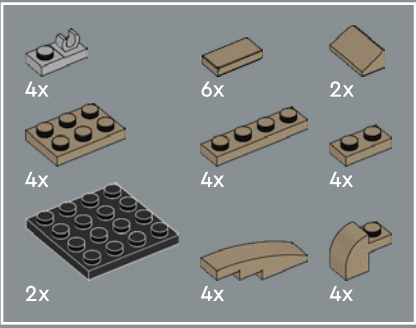

124

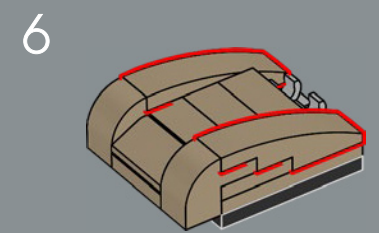
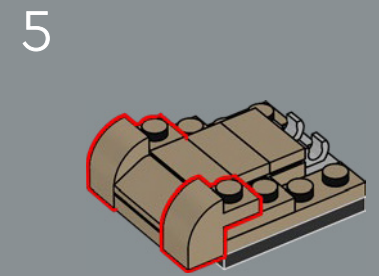
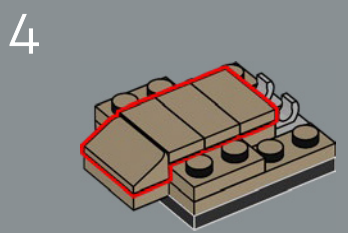
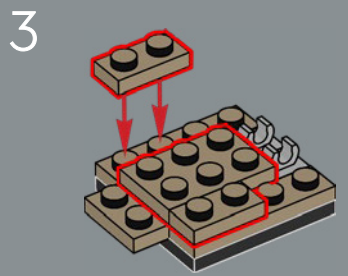
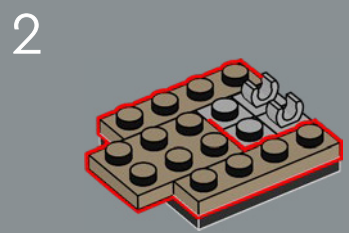
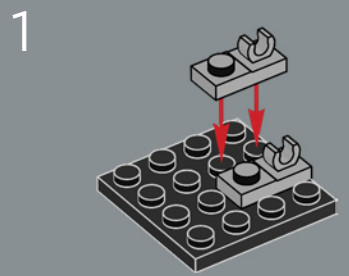

2x

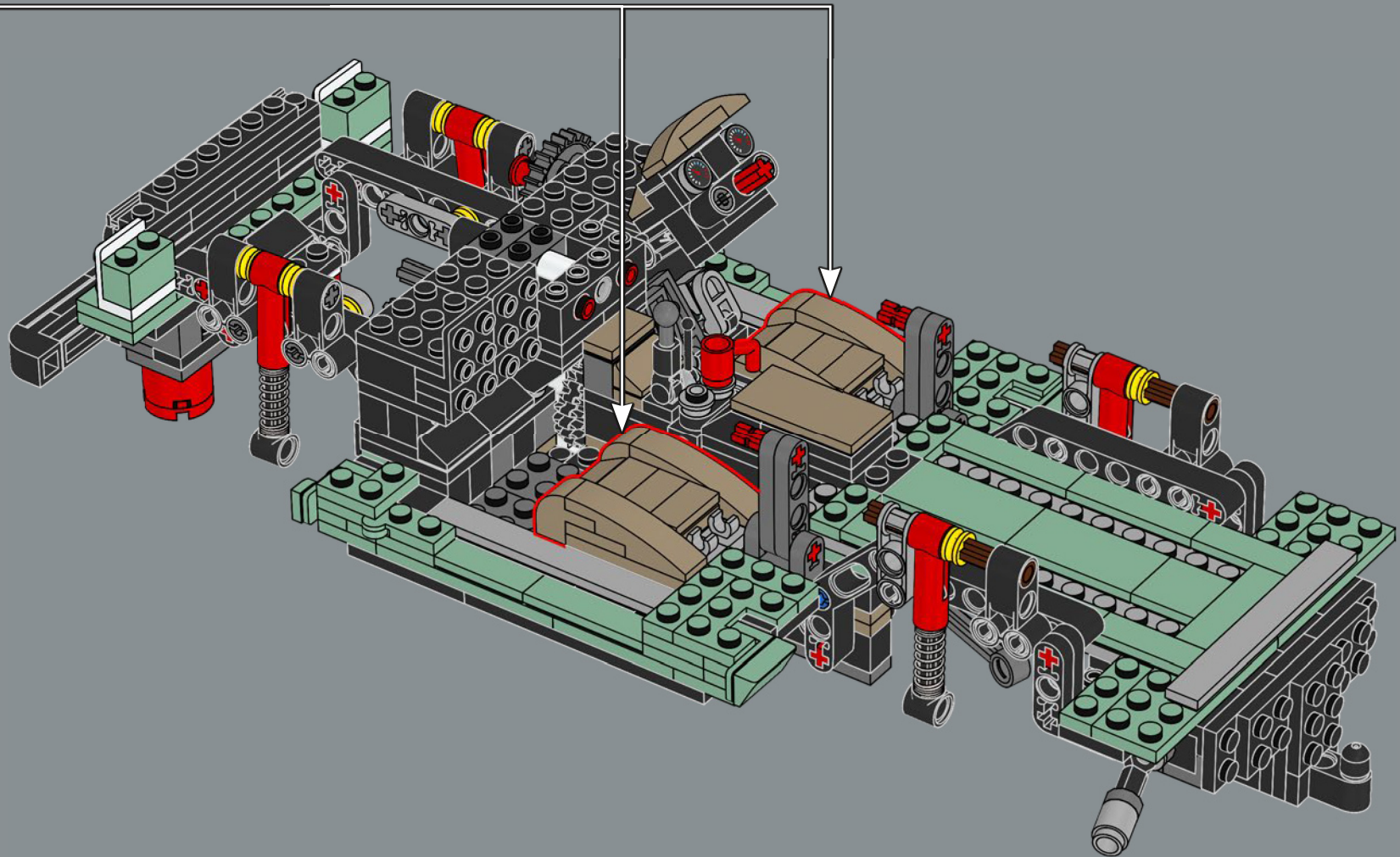

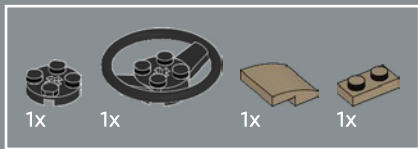

125

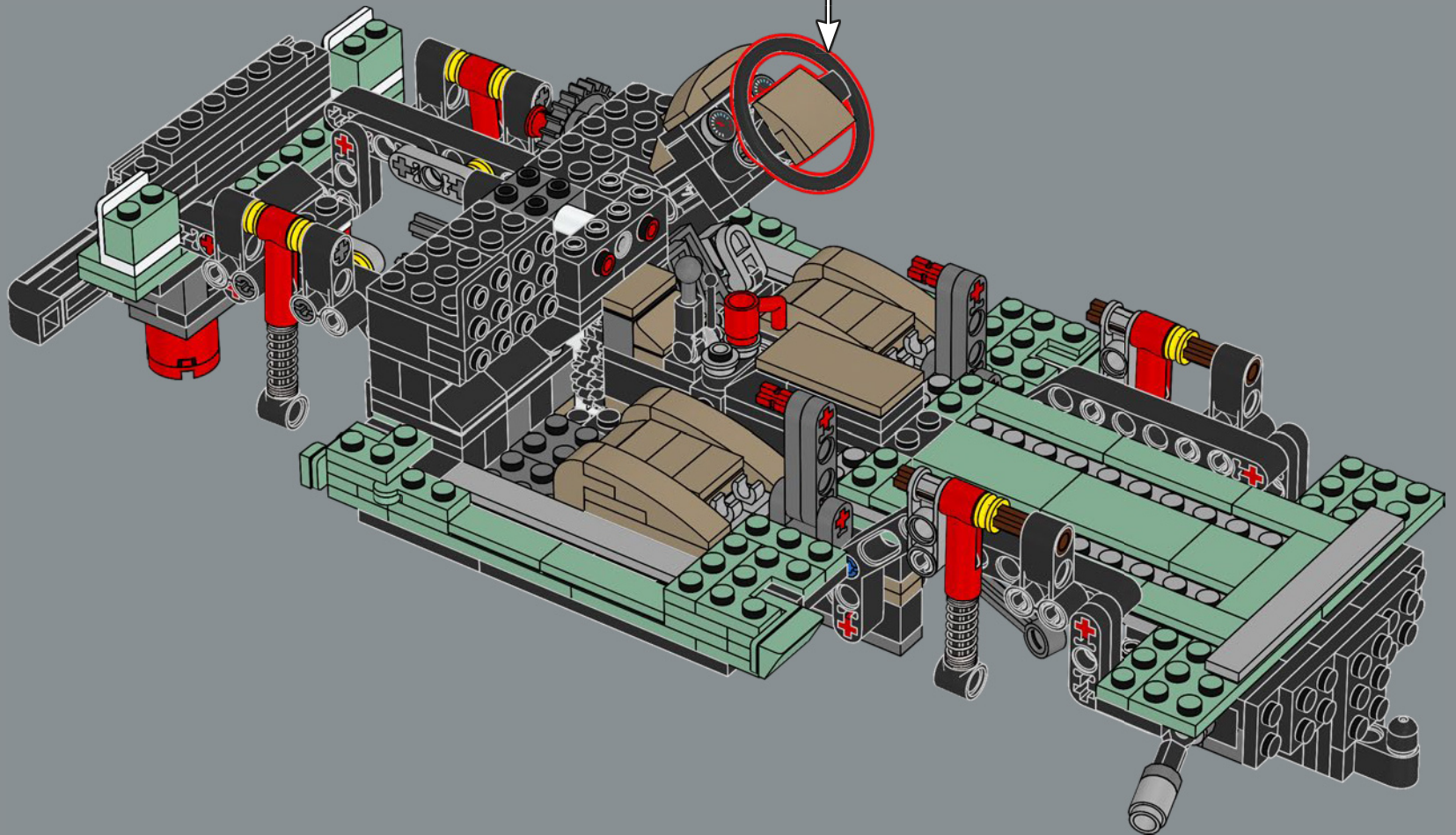
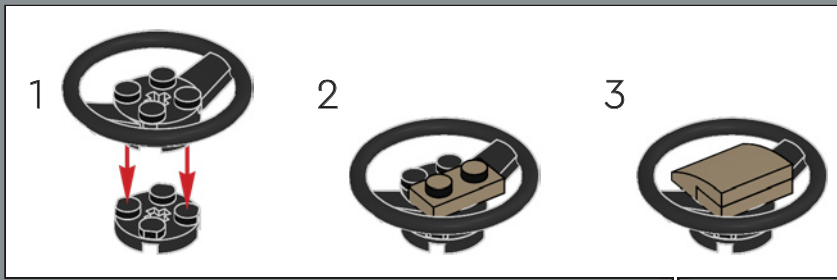

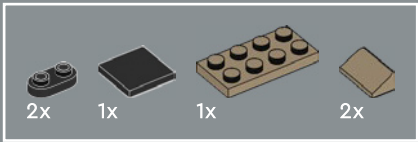

126

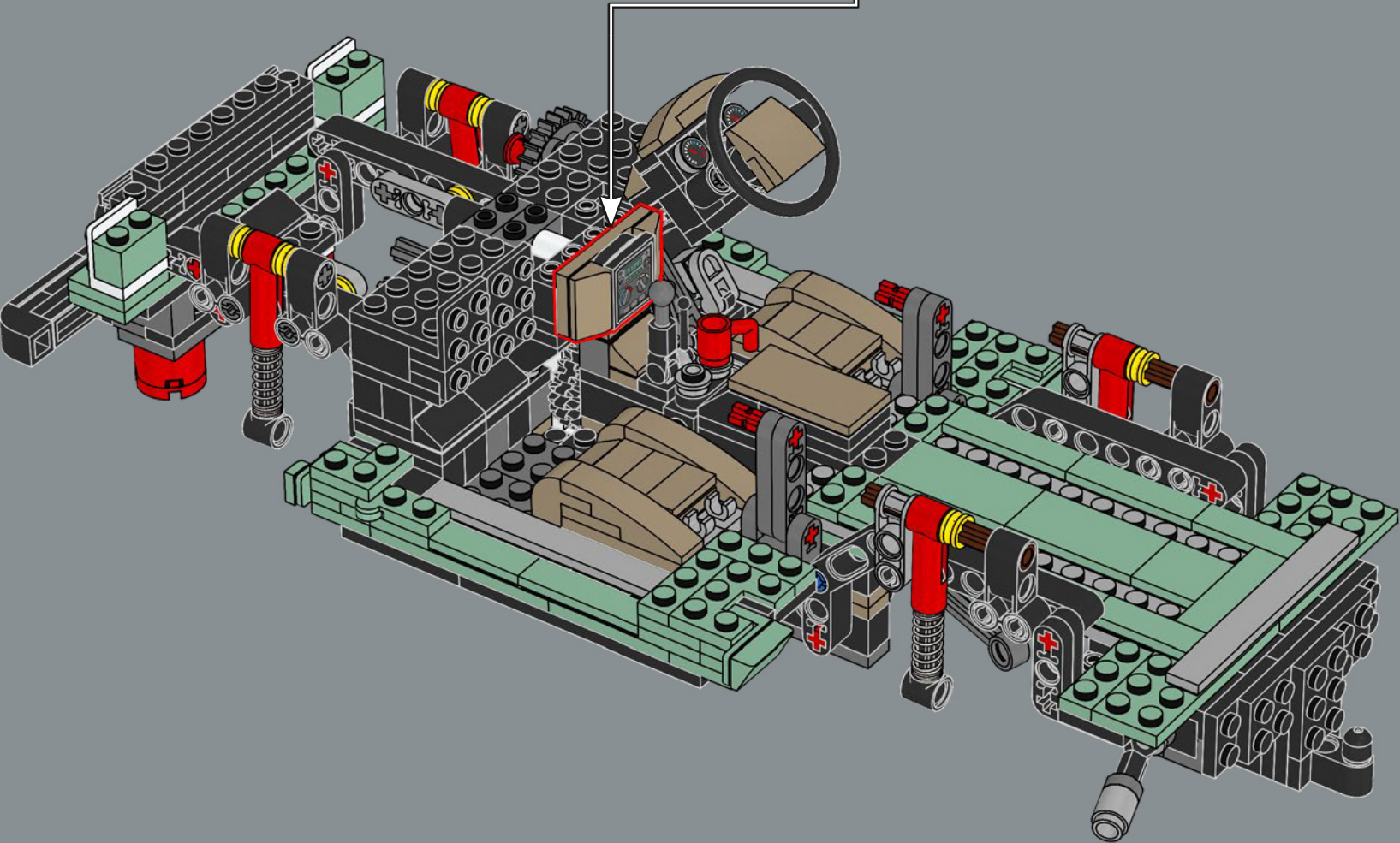
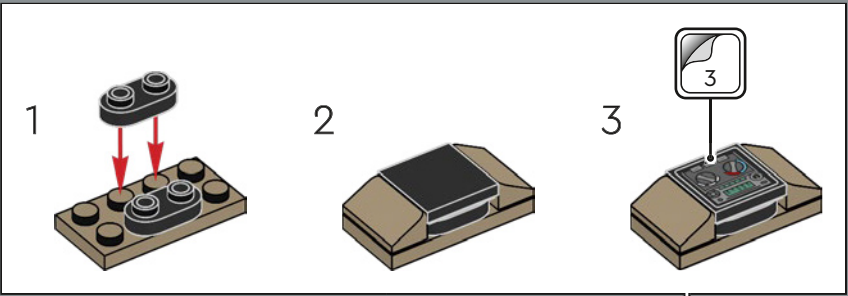

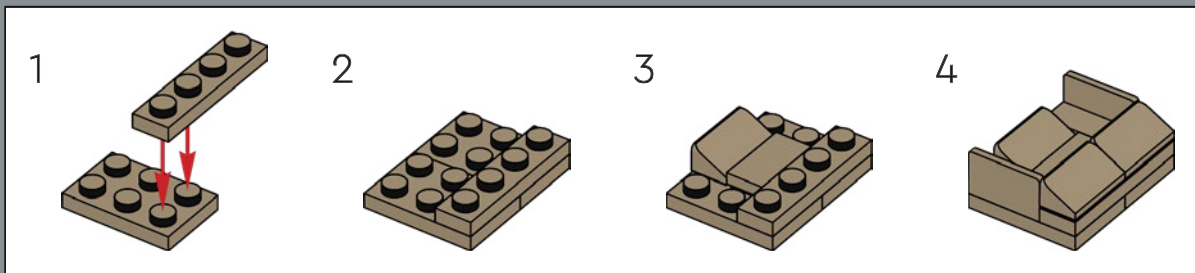
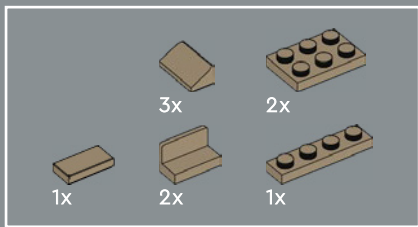

127

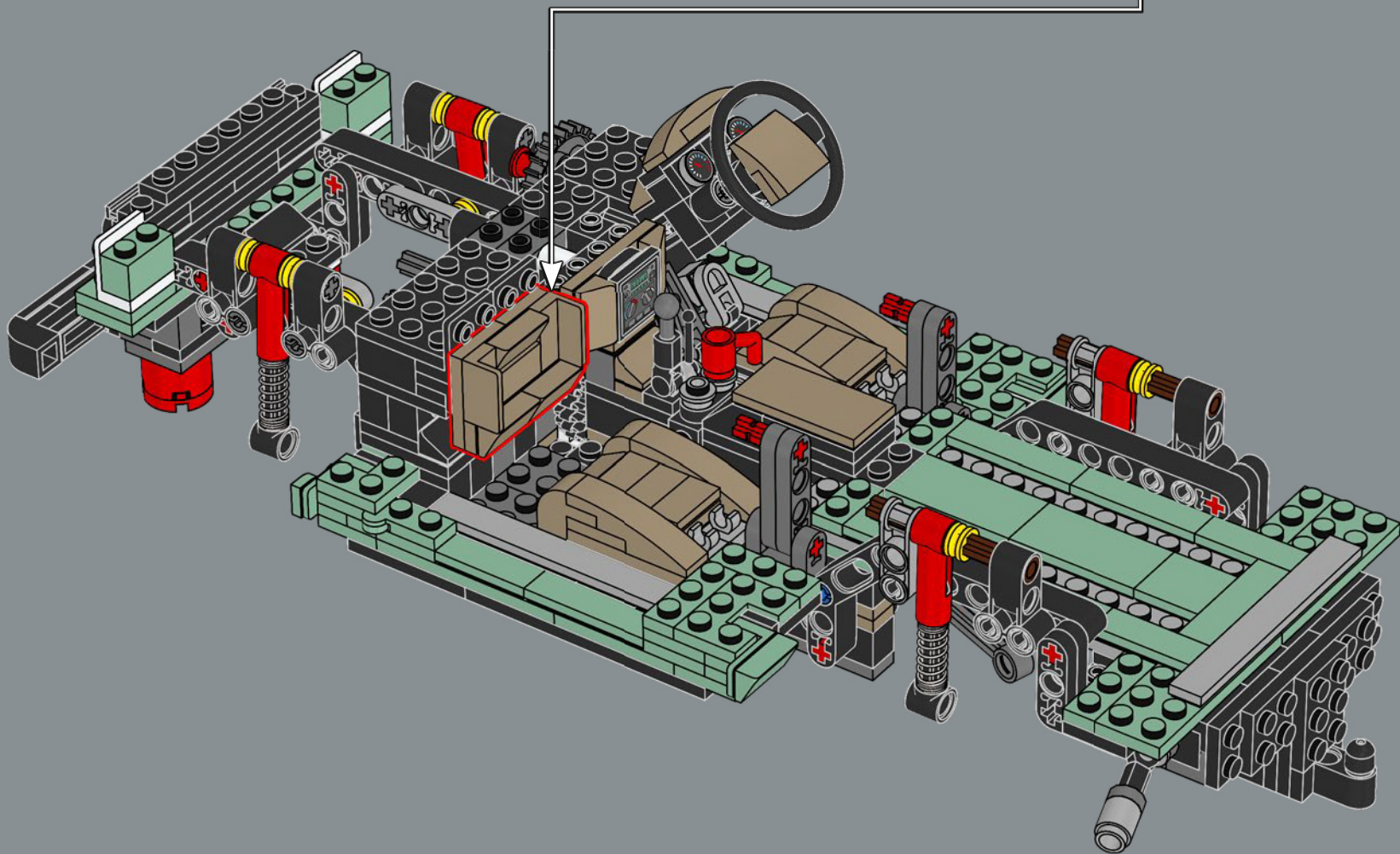

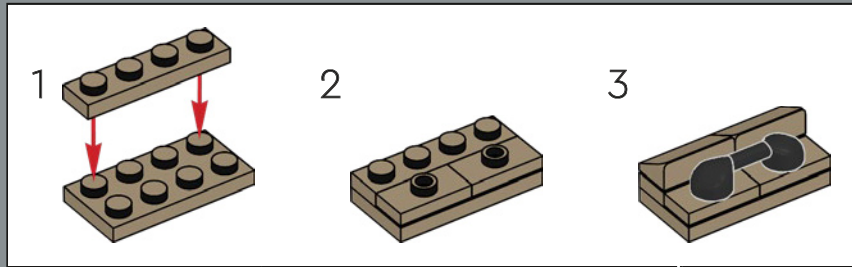
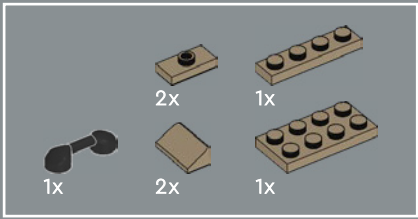

128

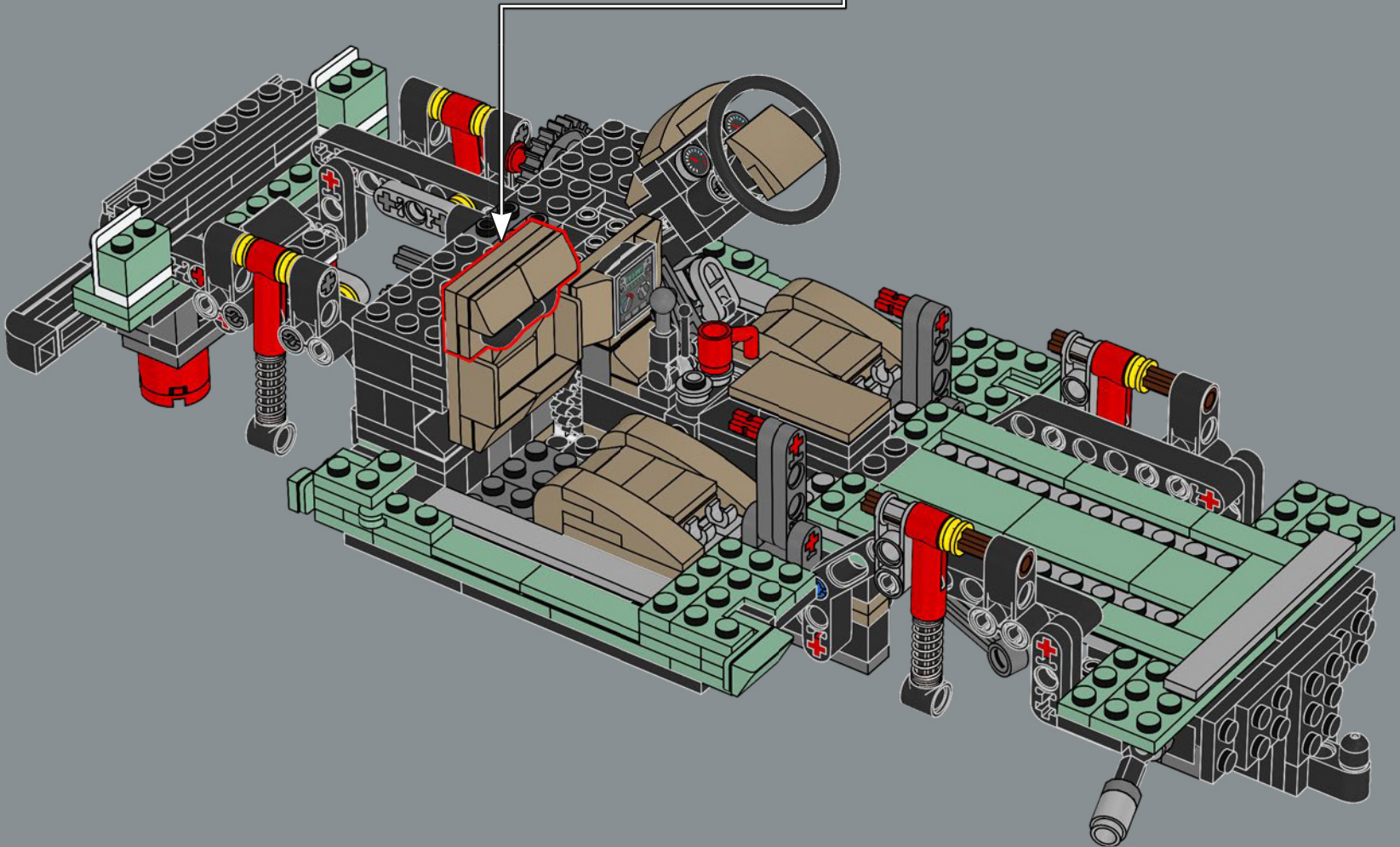

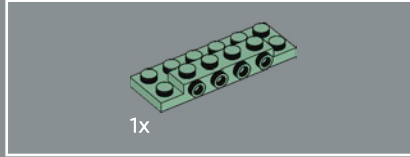
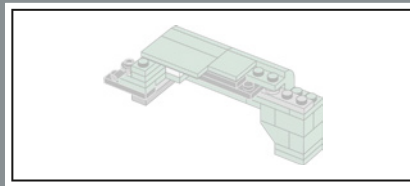

129

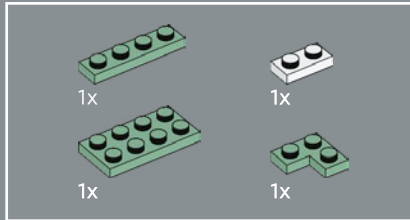
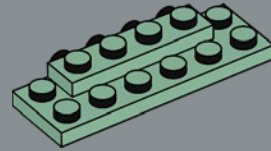

130

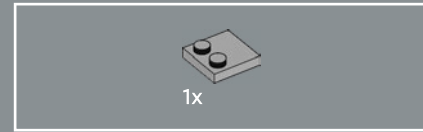
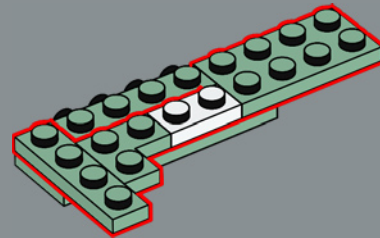

131

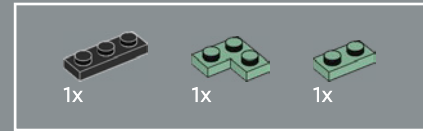
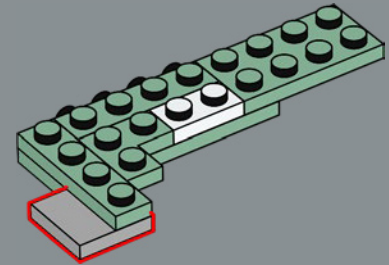

132

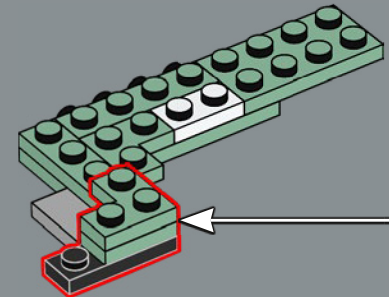
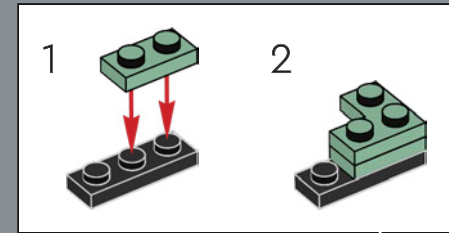

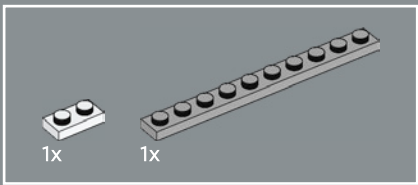

133

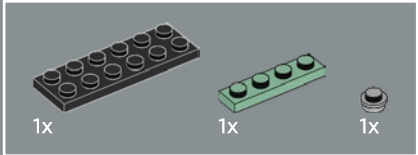
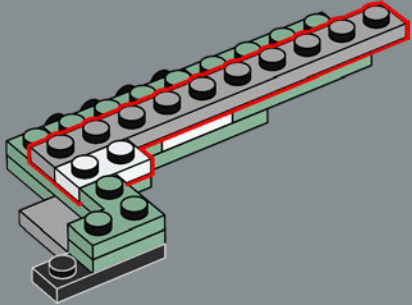

134

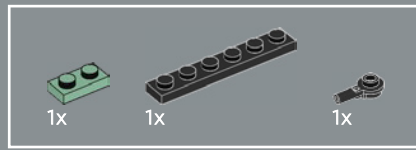
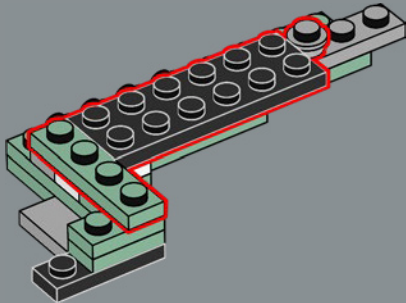

135

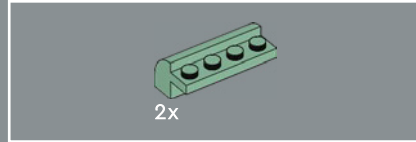
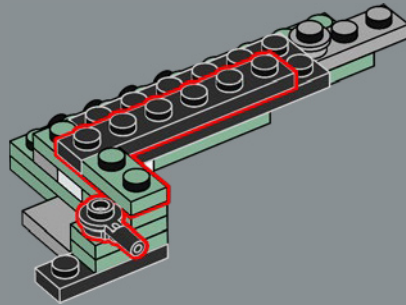

136

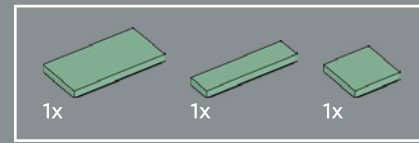
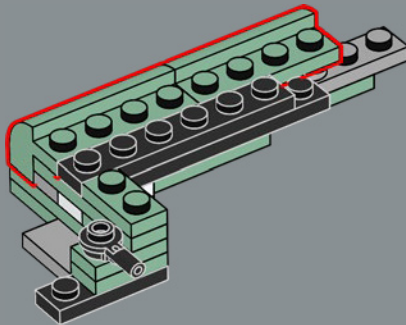

137

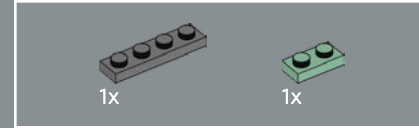
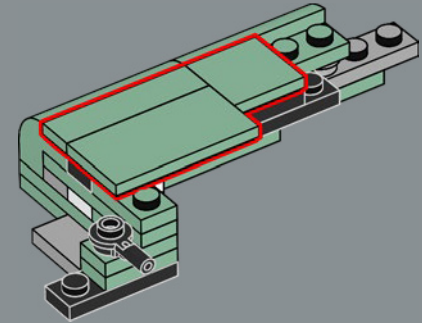

138

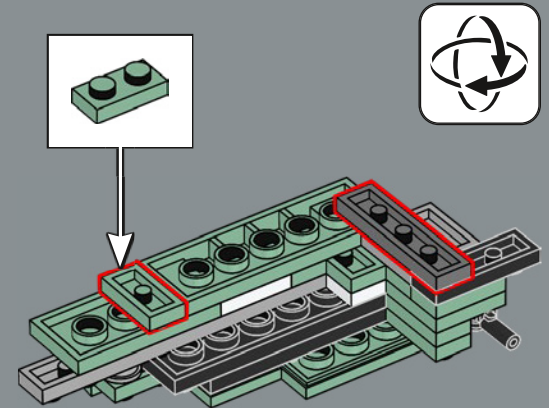

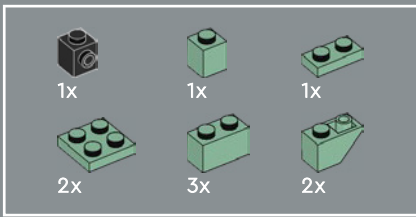

139

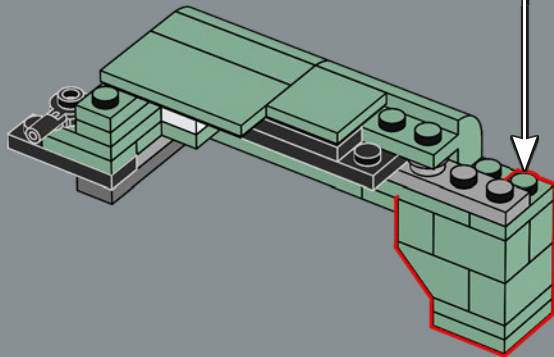
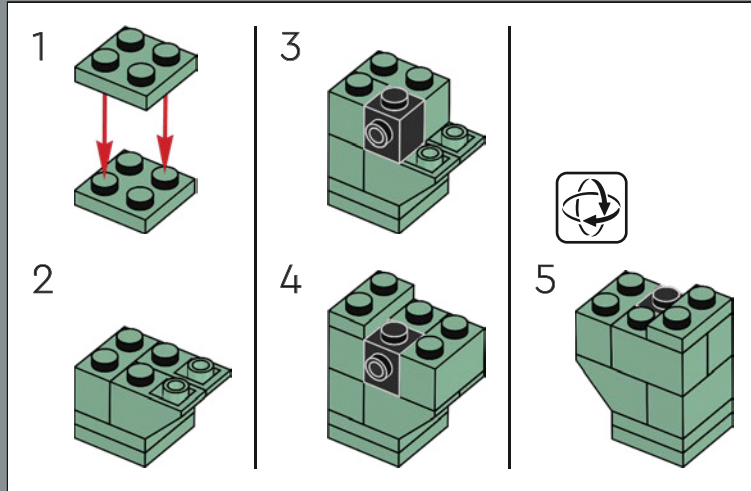

140

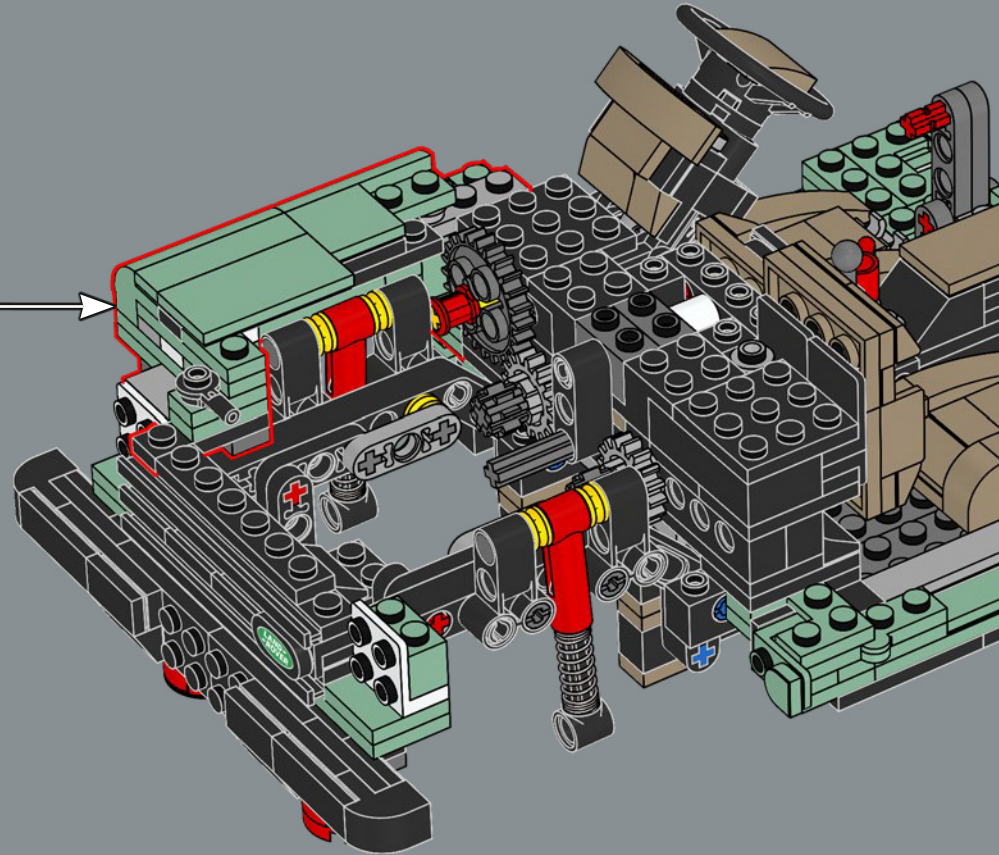

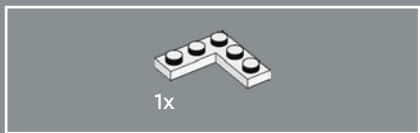

141

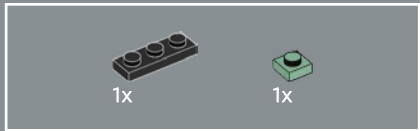

142

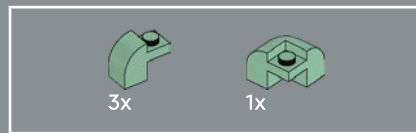
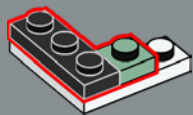

143

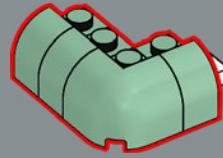

144

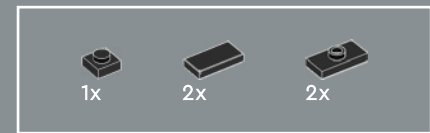
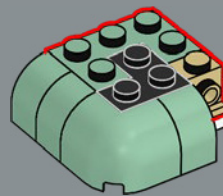

145

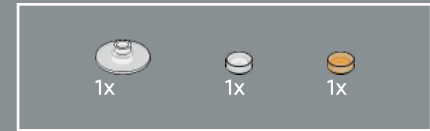
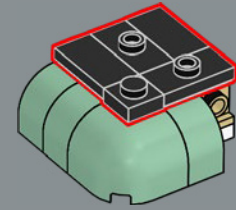

146

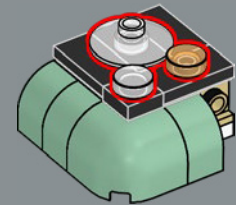

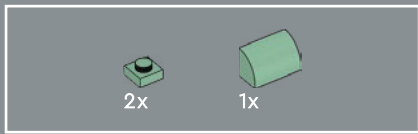

147

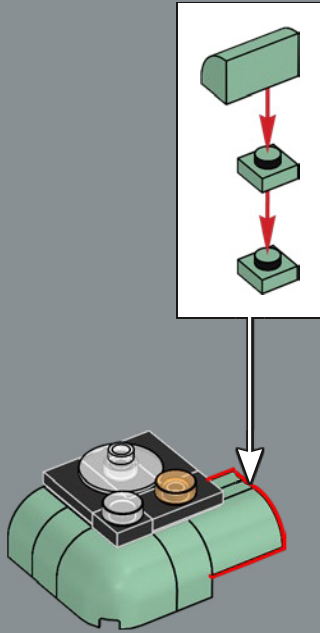

148

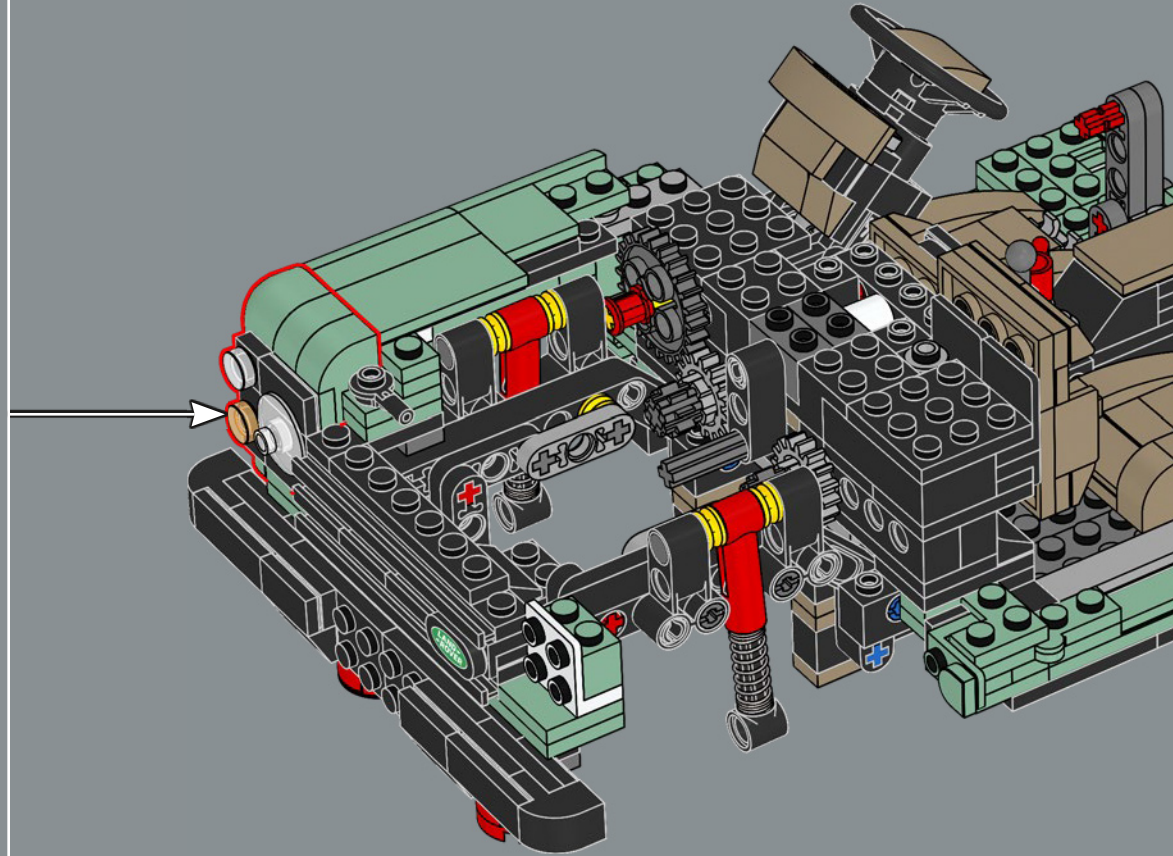

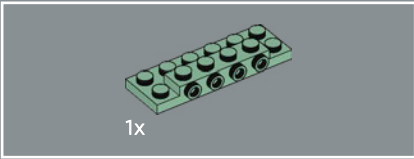
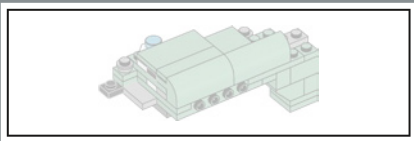

149

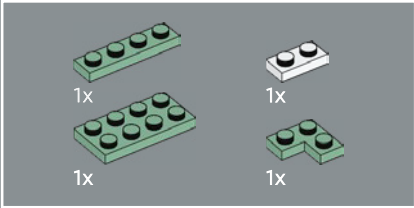
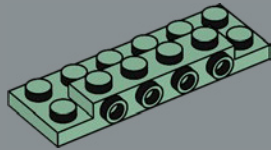

150

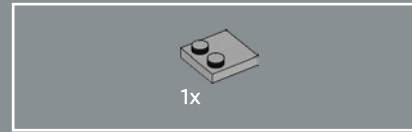
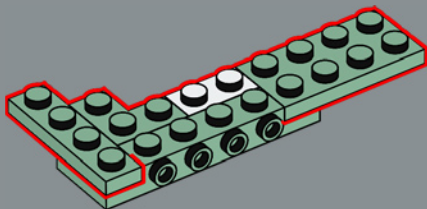

151

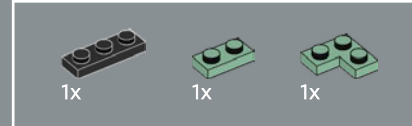
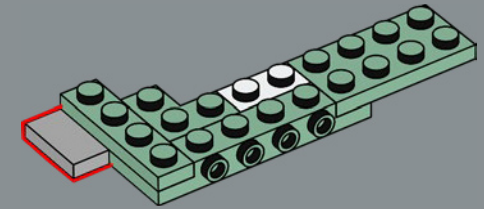

152

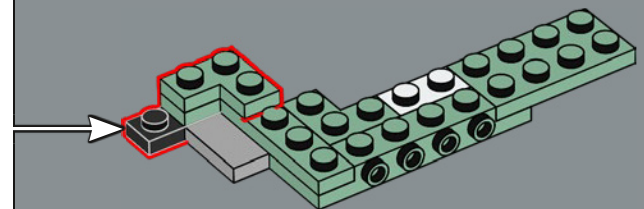
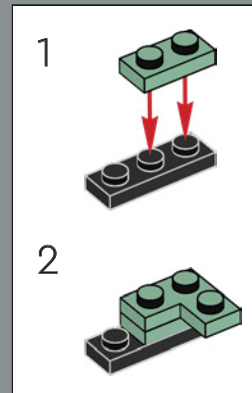

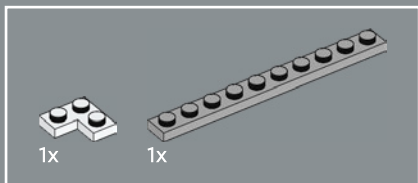

153

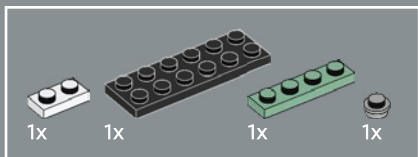
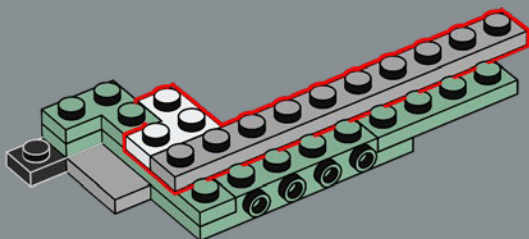

154

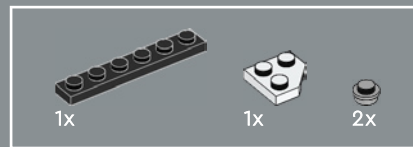
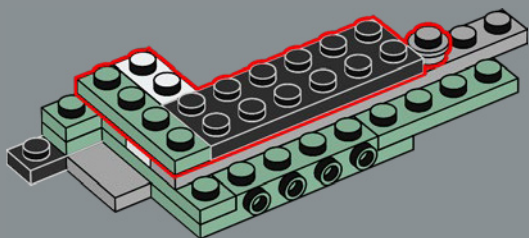

155

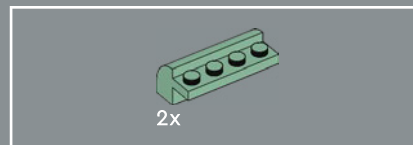
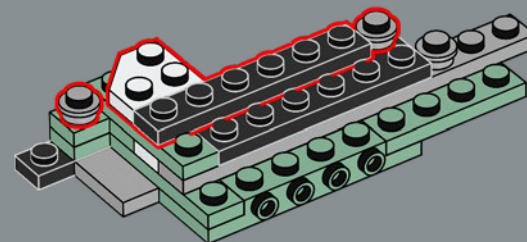

156

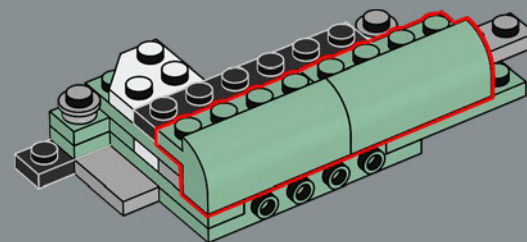

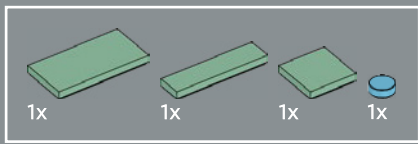

157

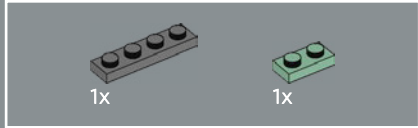
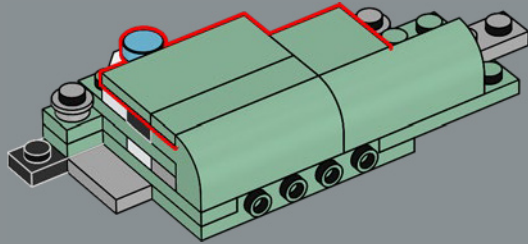

158

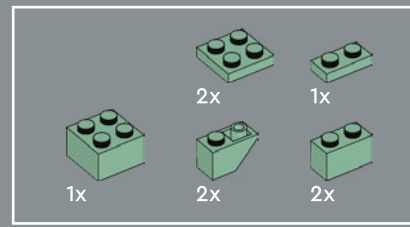
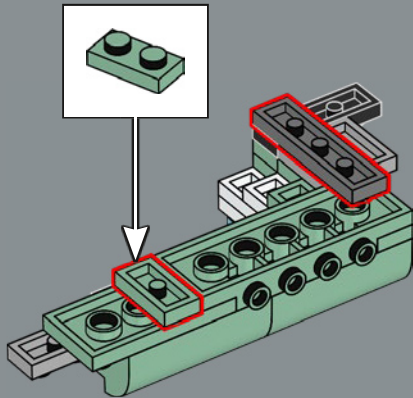

159

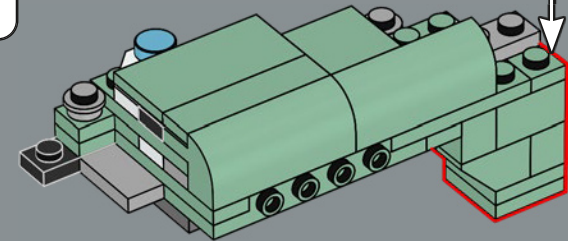
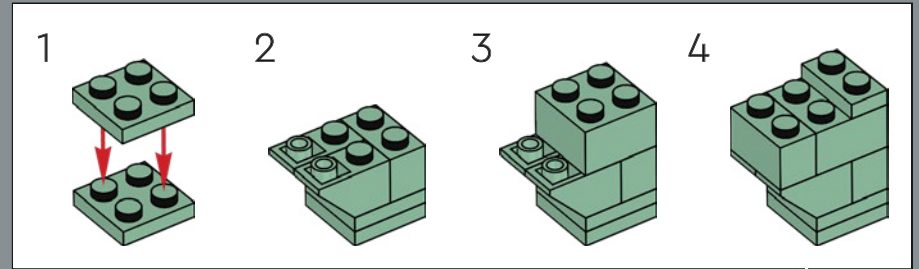

160

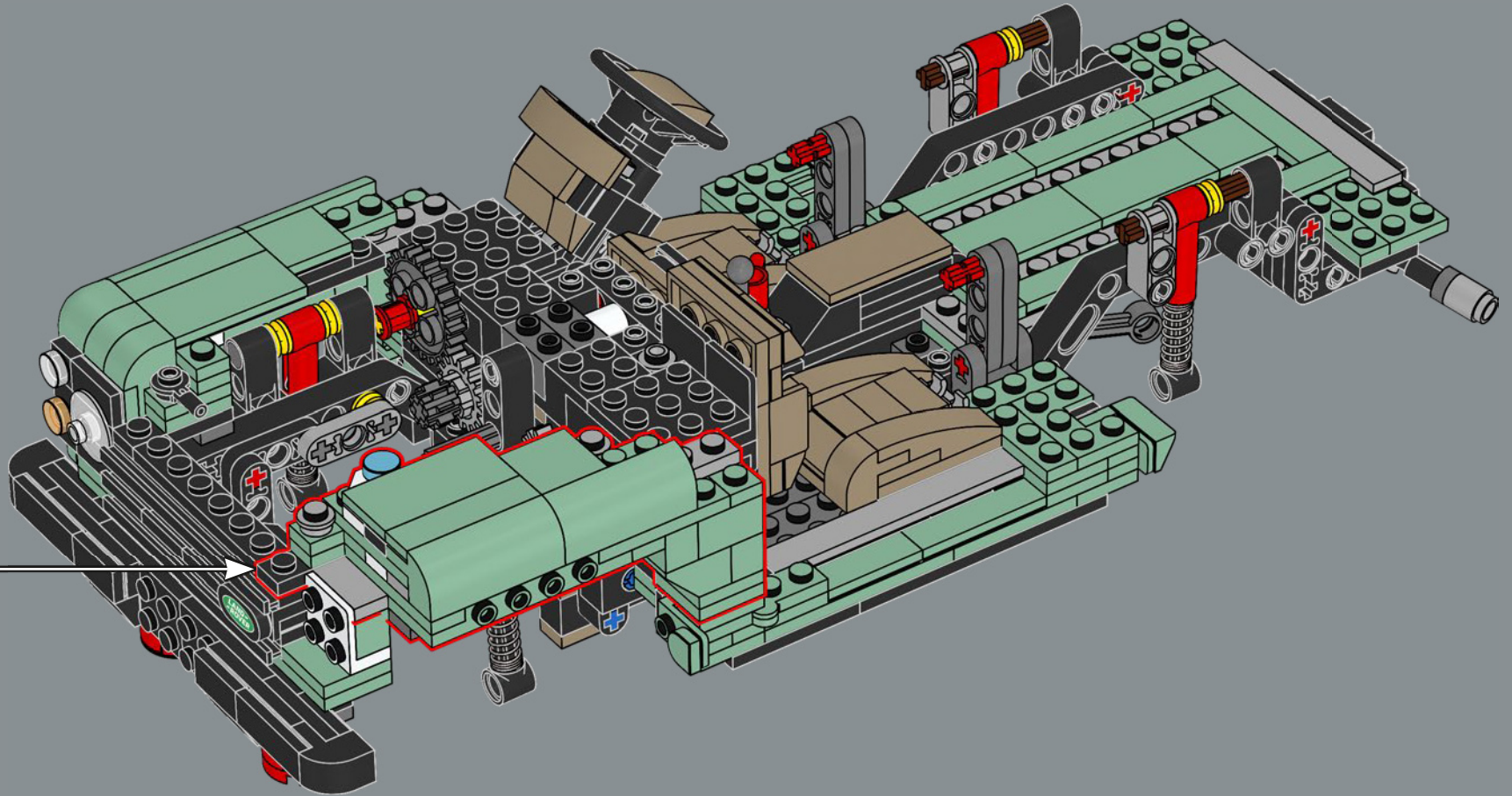

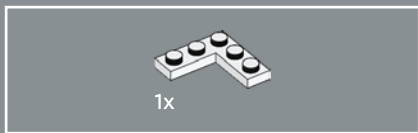

161

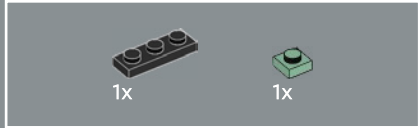
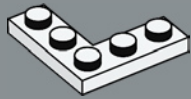

162

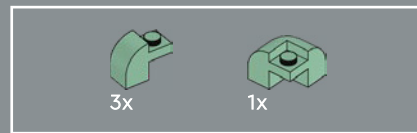

163

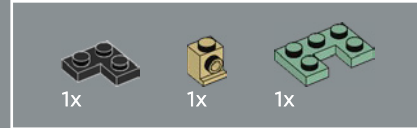
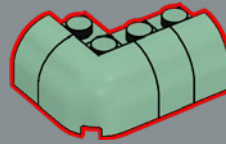

164

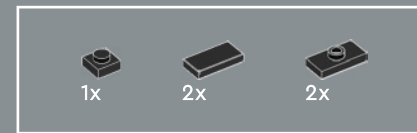
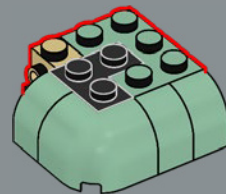

165

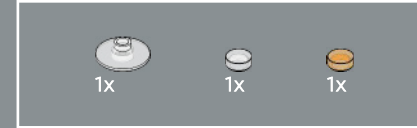
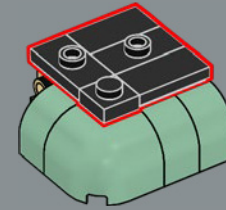

166

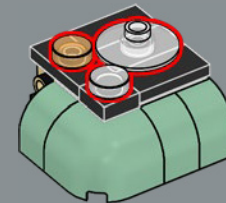

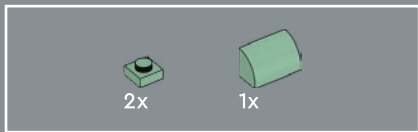

167

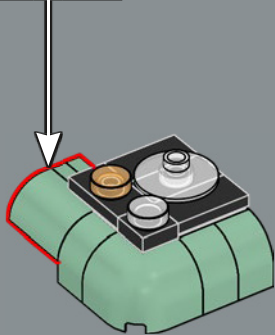
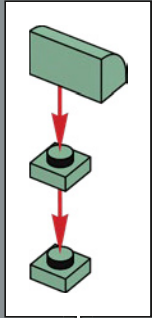

168

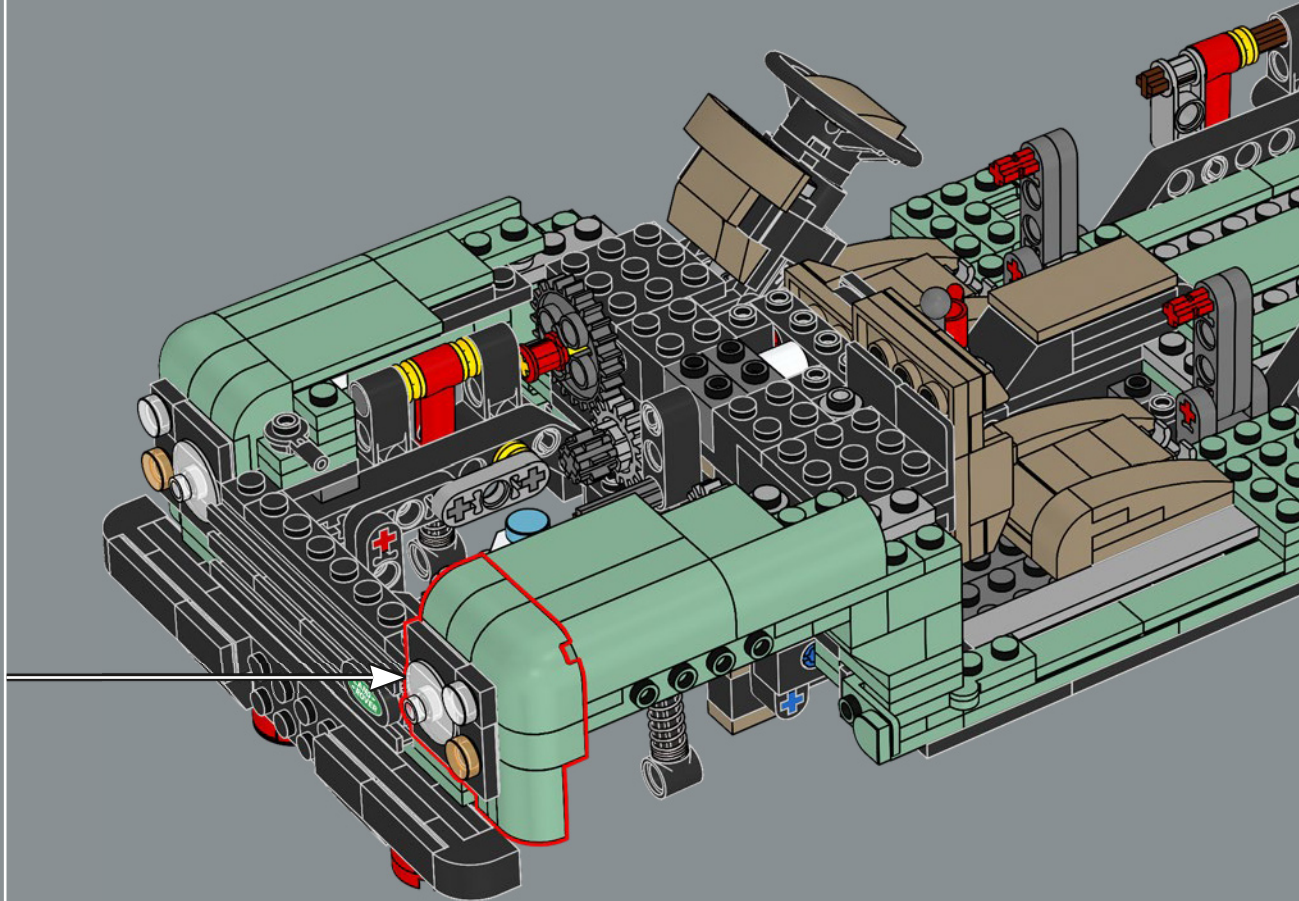

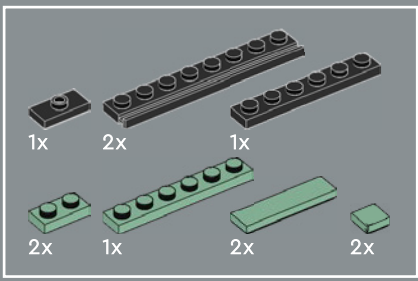

169

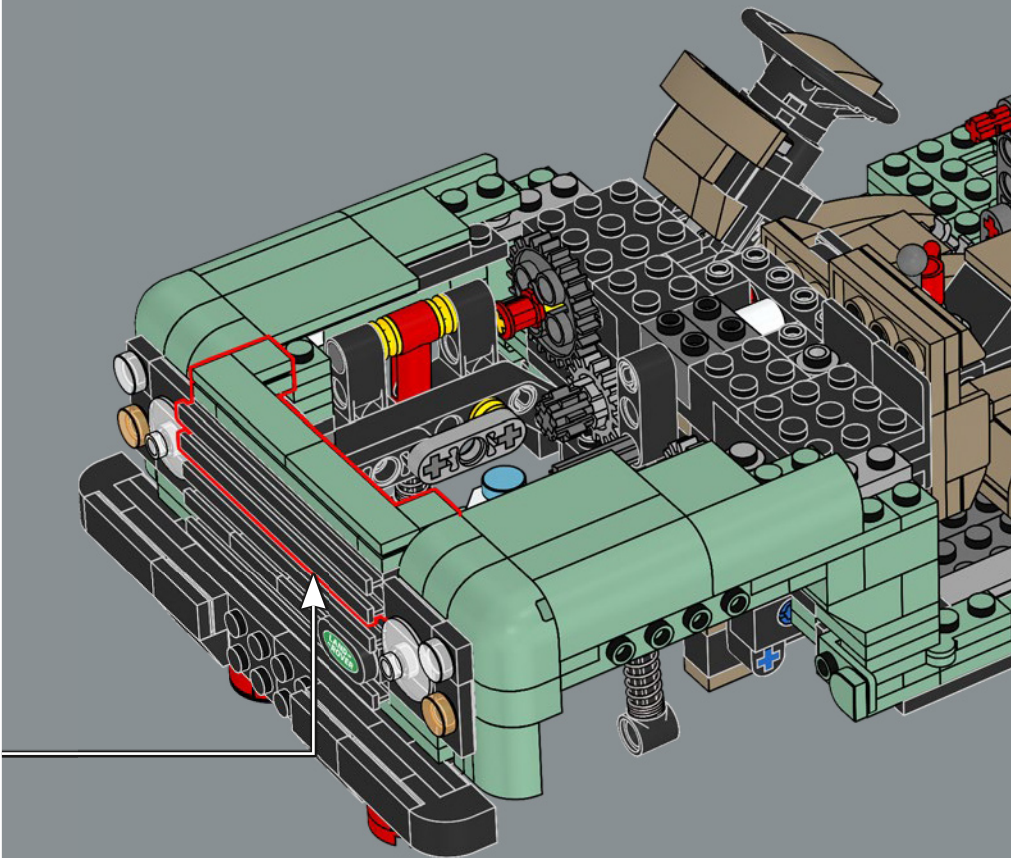
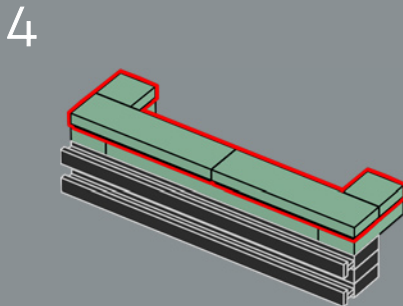
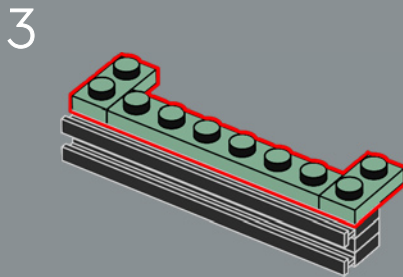
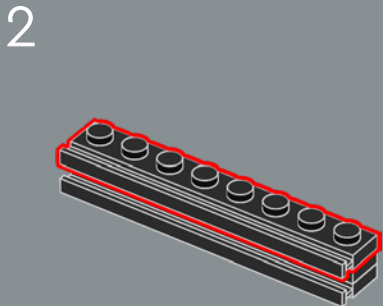
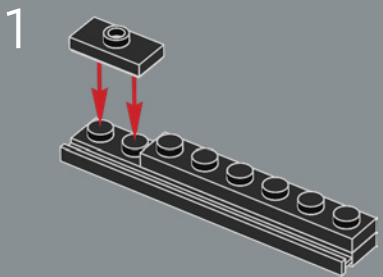

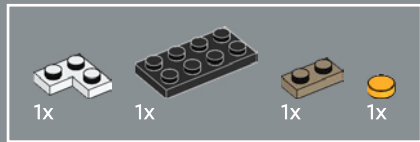

170

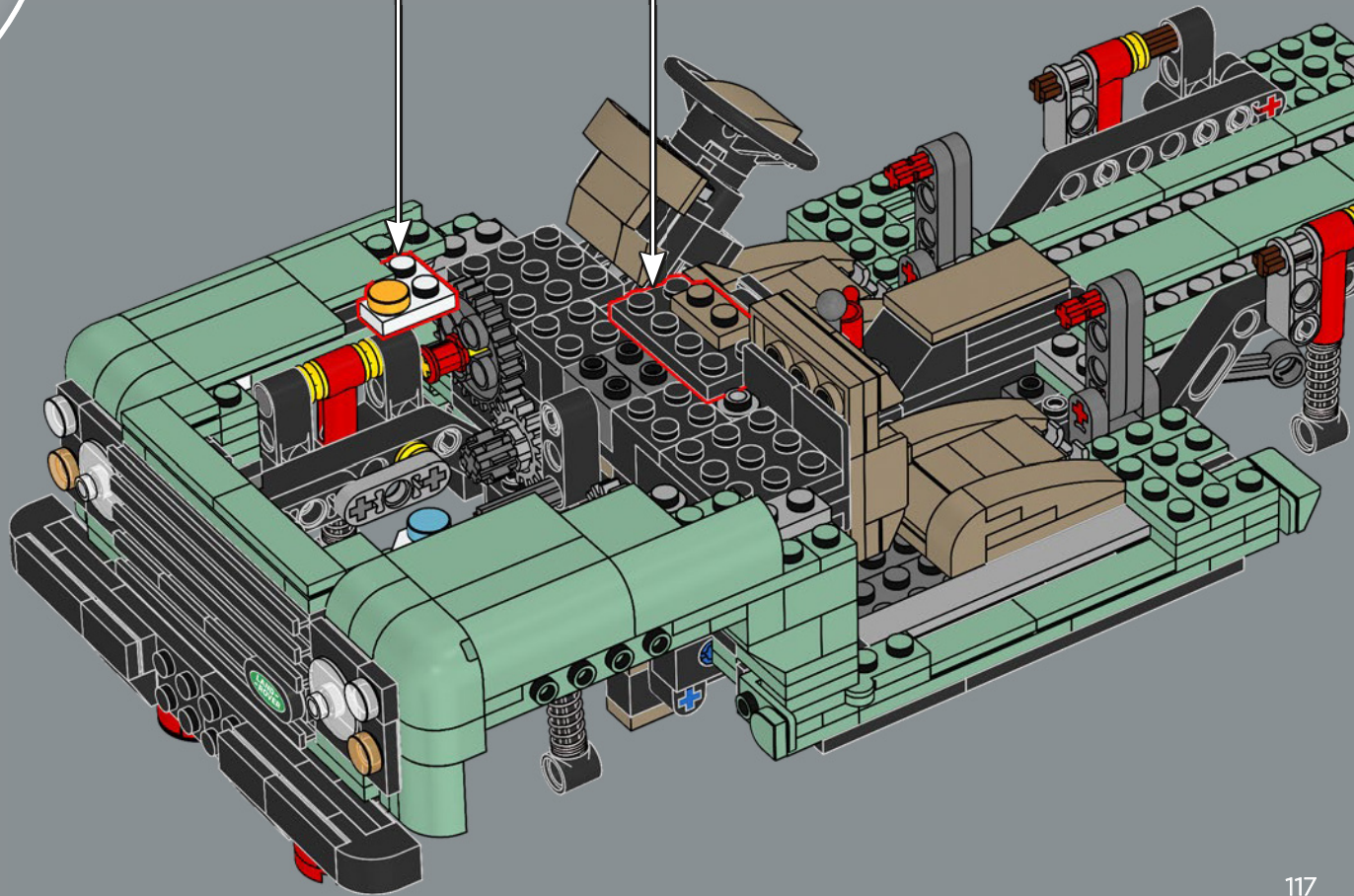
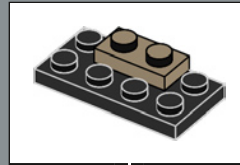
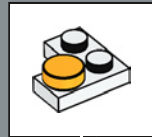

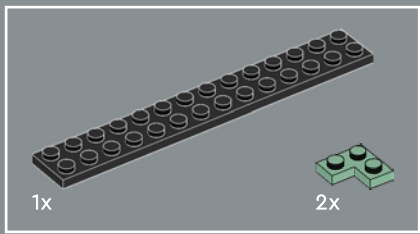

171

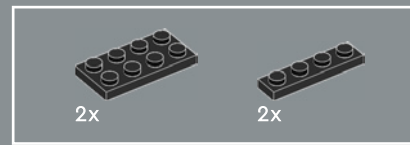
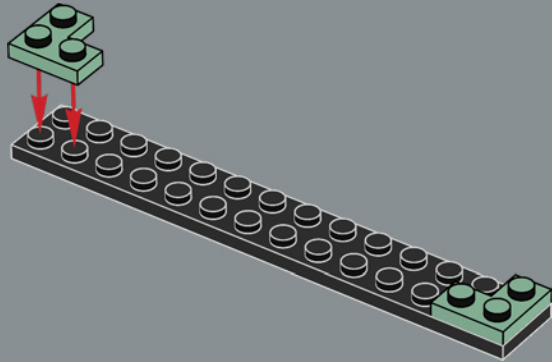

172

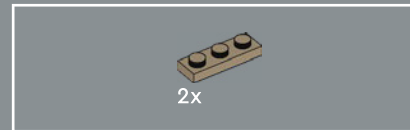
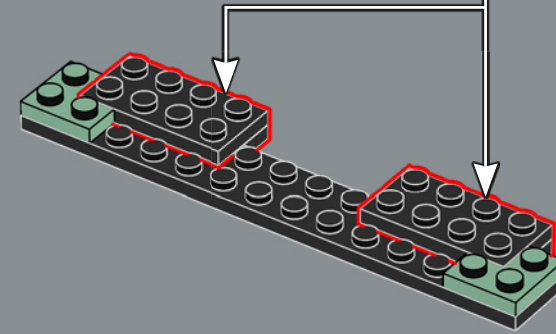
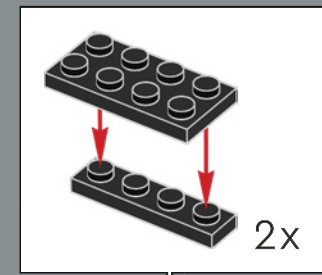

173

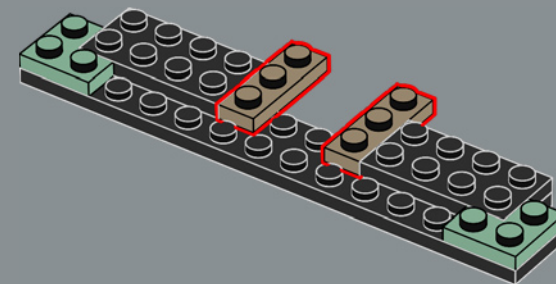



174

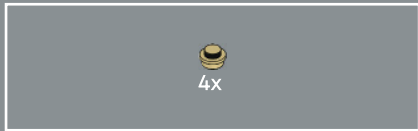
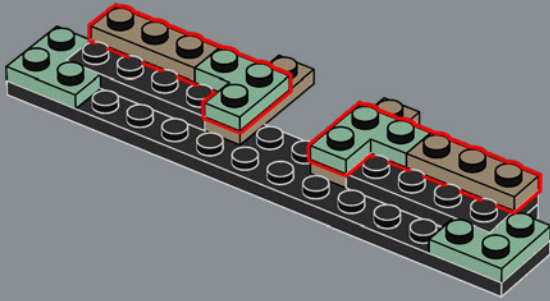

175

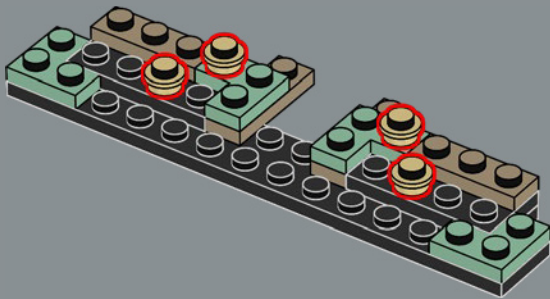

176

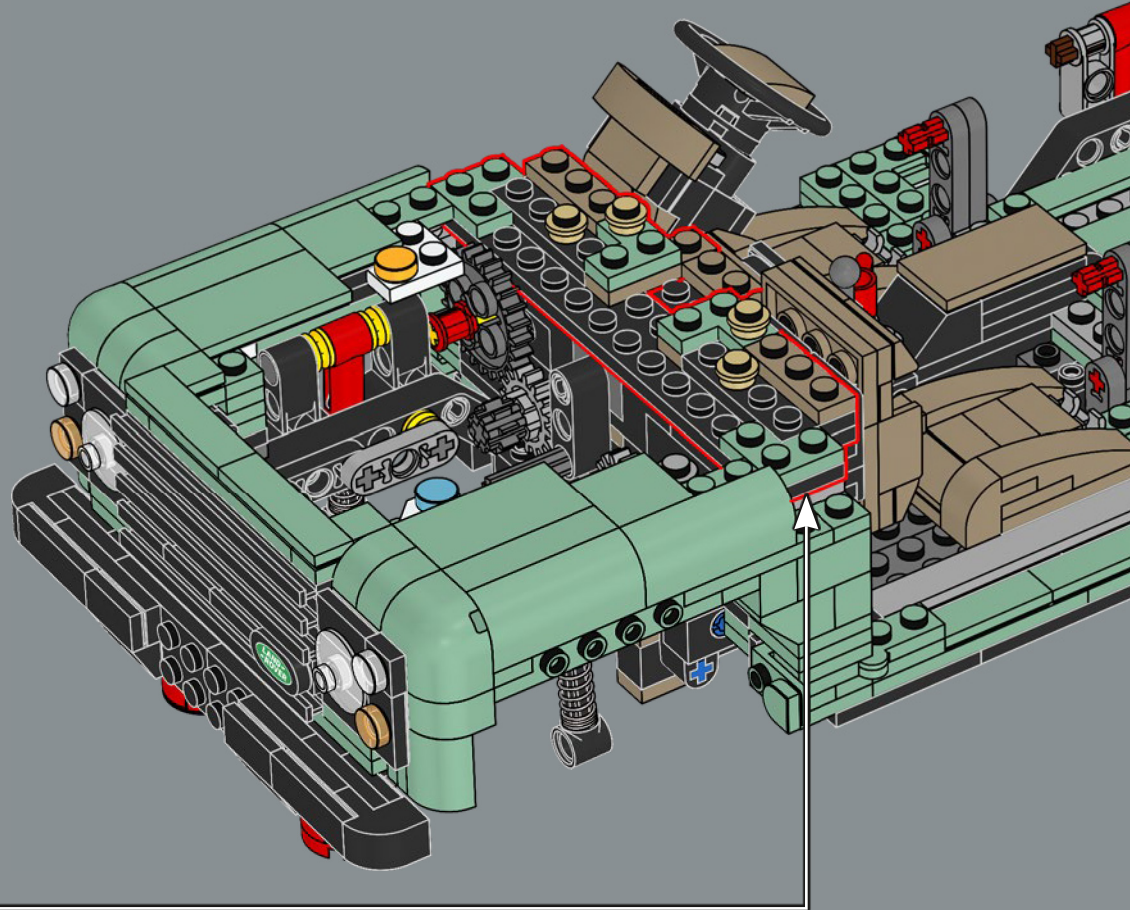

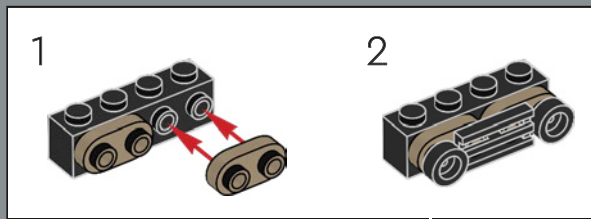
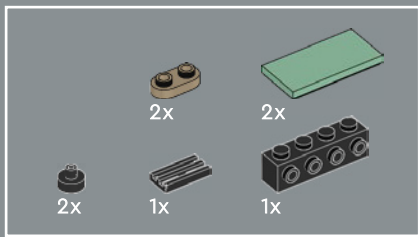

177

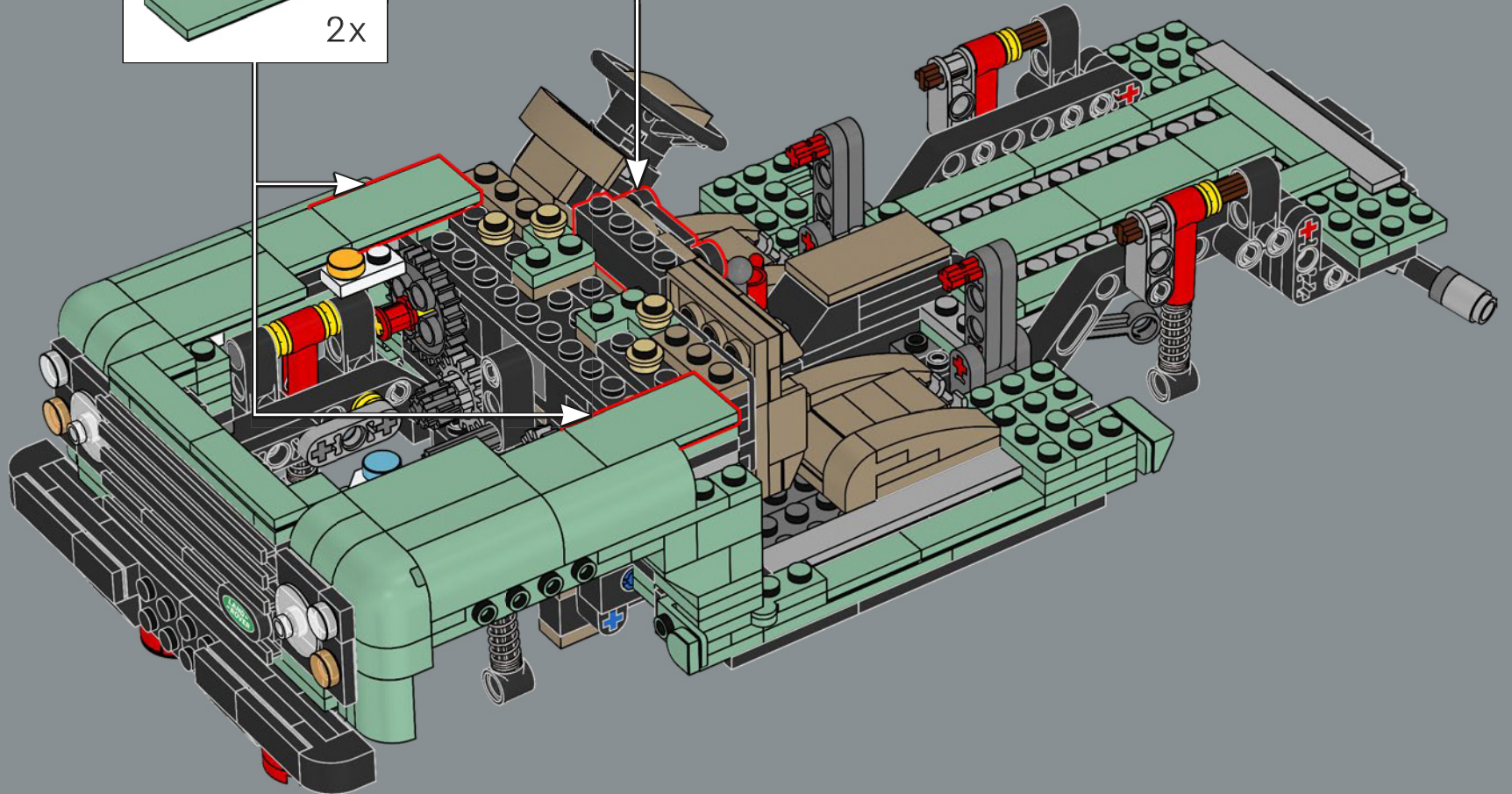
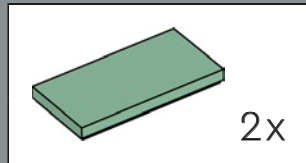

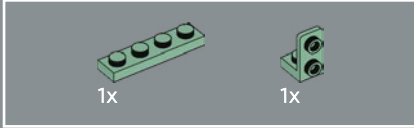
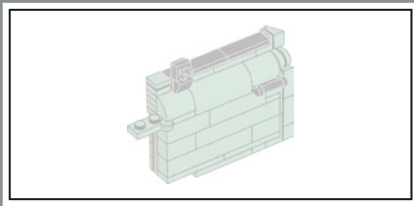

178

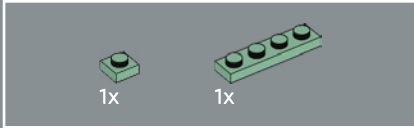
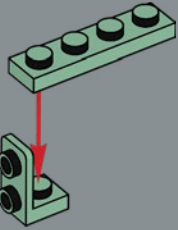

179

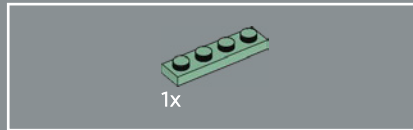
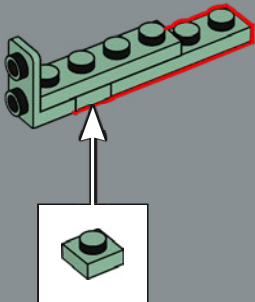

180

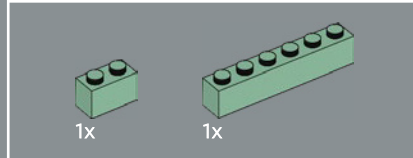
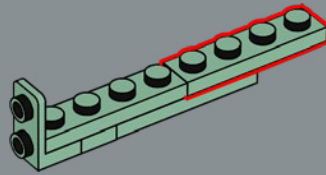

181

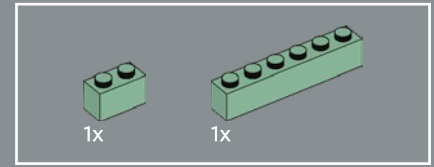
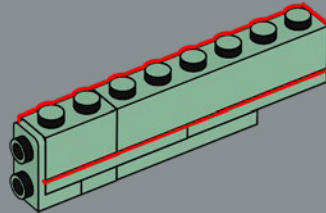

182

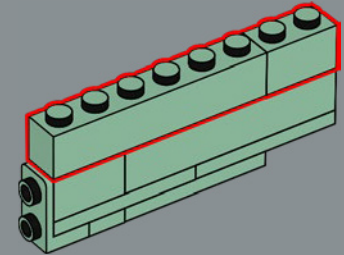

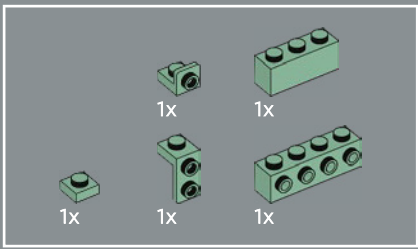

183

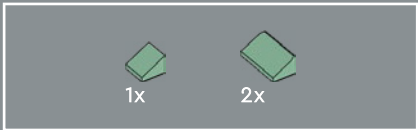
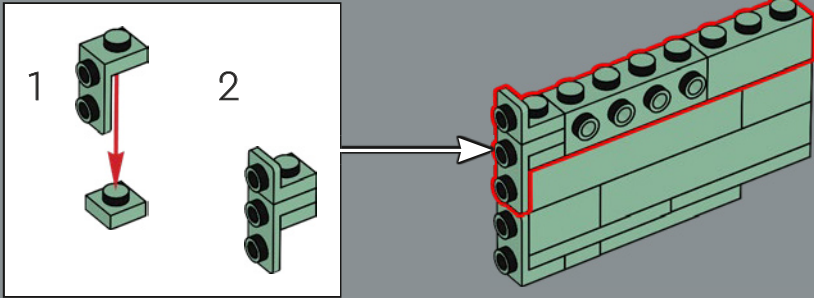

184

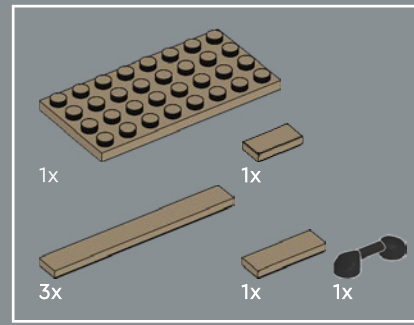
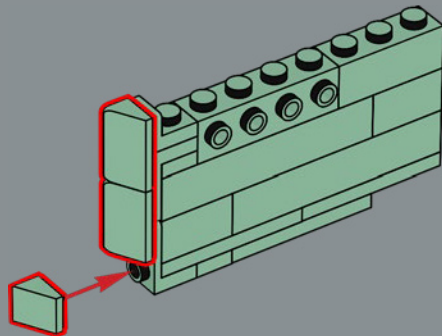

185

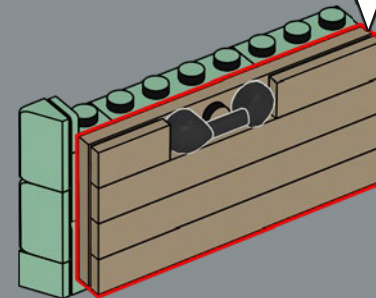
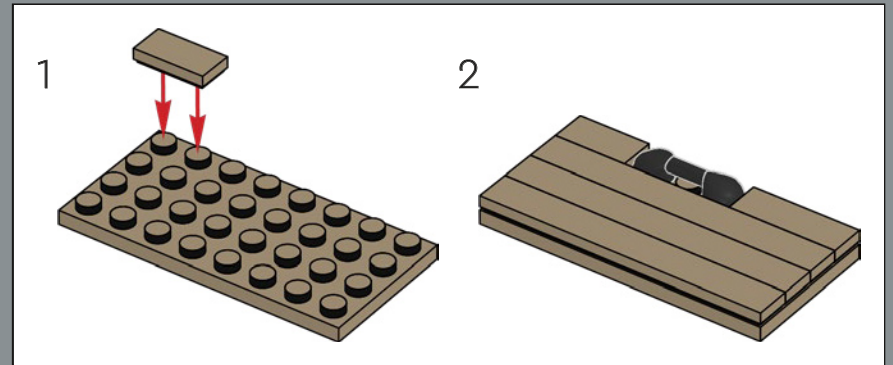

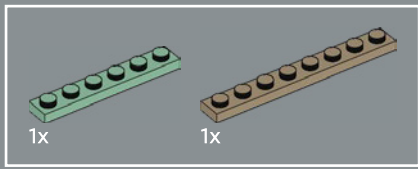

186

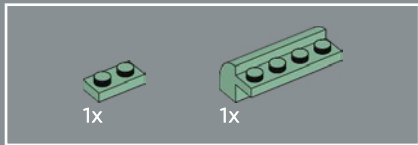
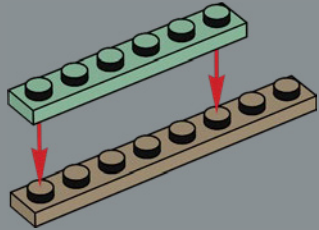

187

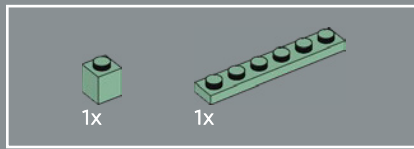
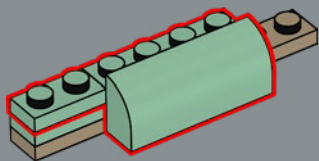

188

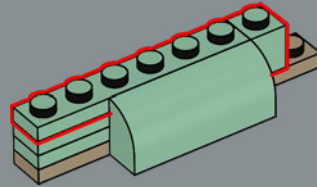

189

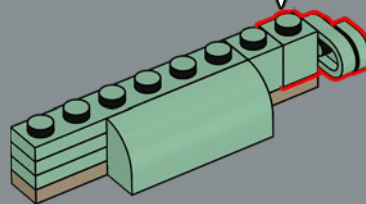
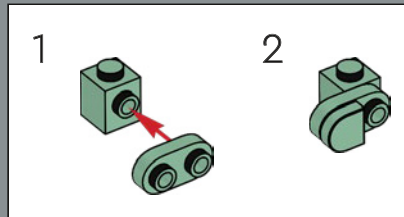

190

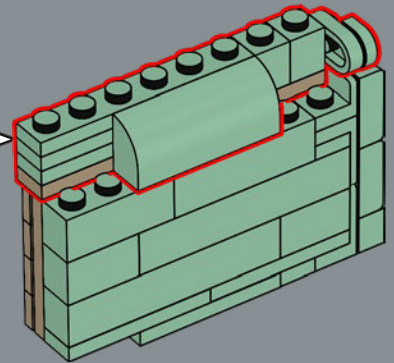

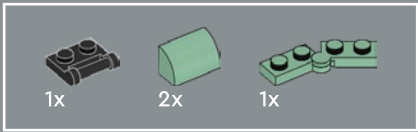

191

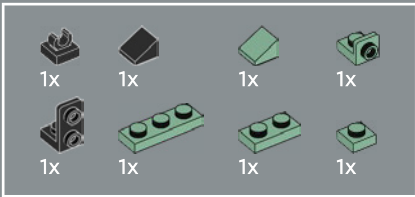
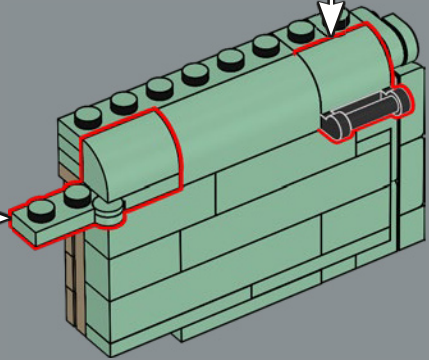
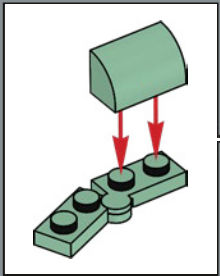
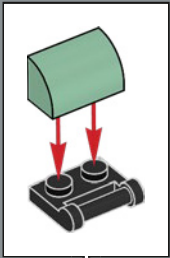

192

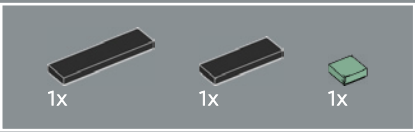
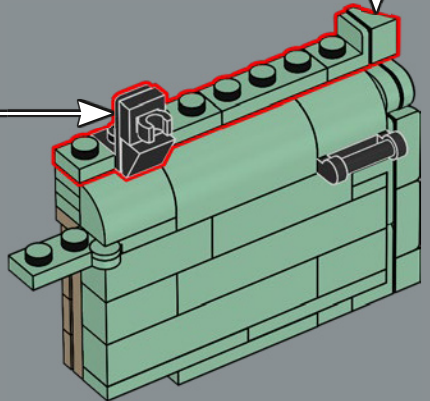
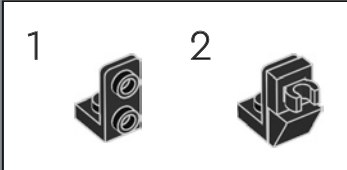
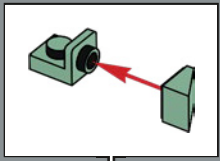

193

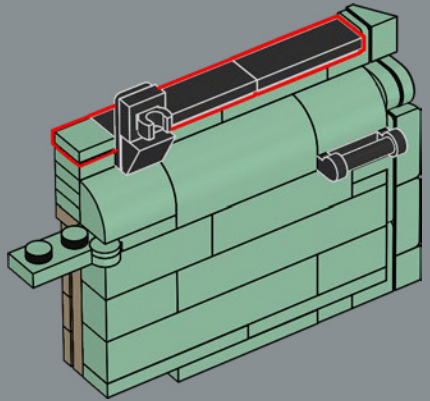

194

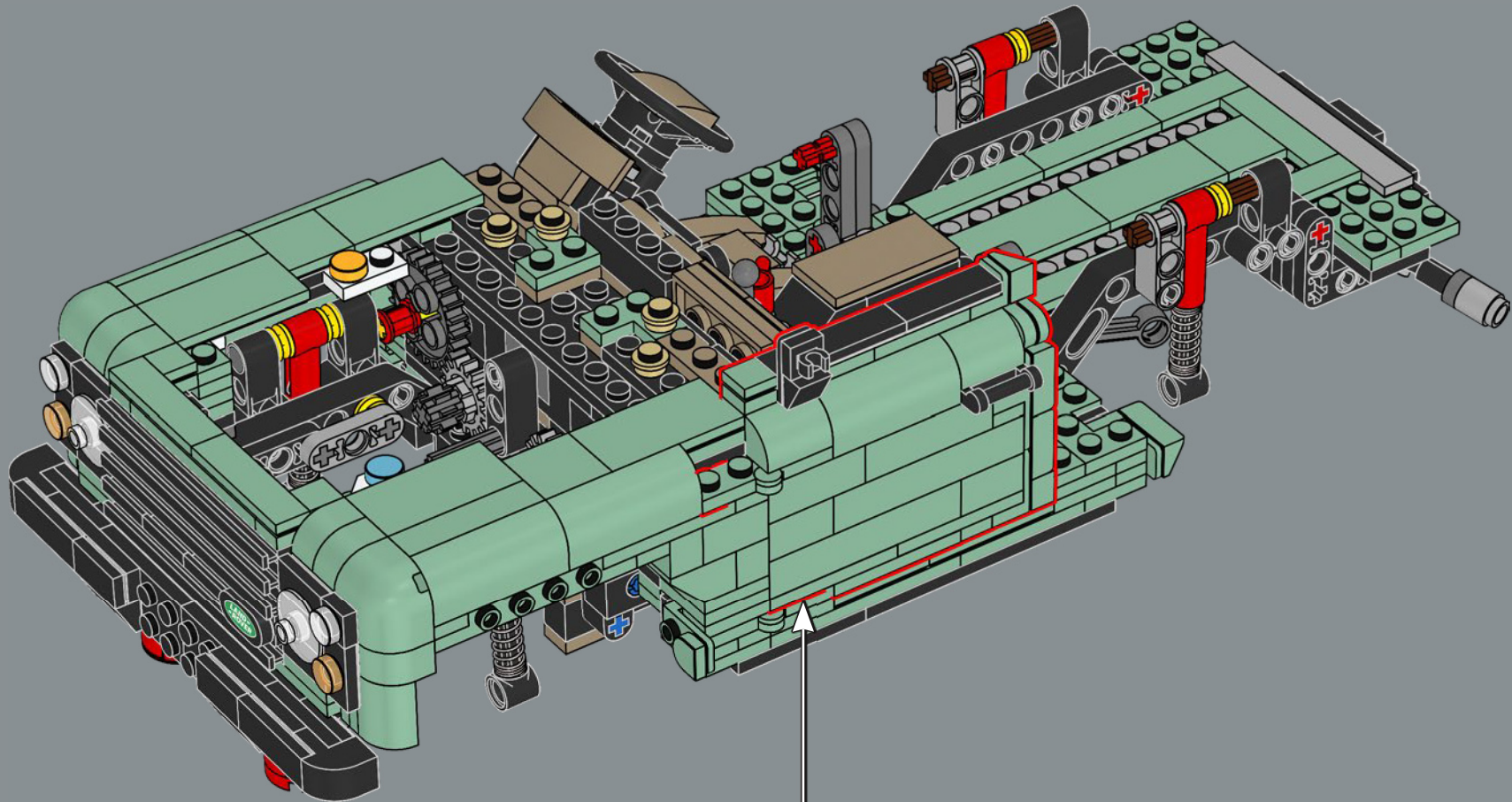

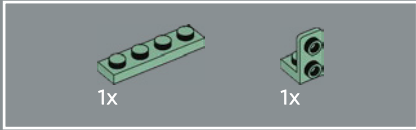
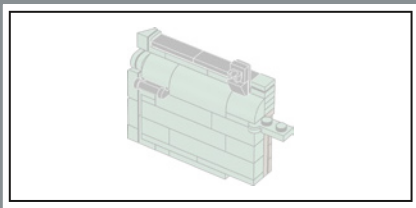

195

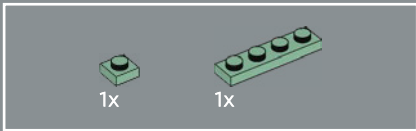
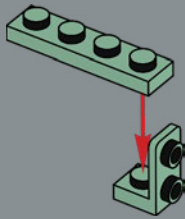

196

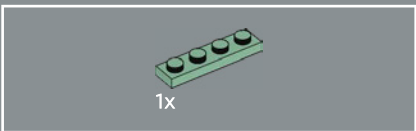
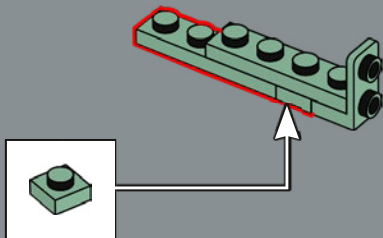

197

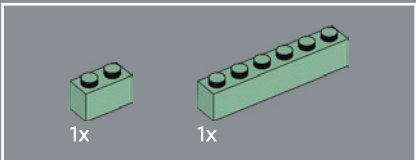
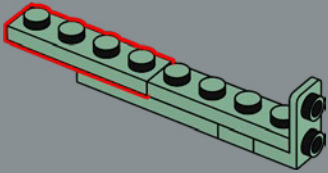

198

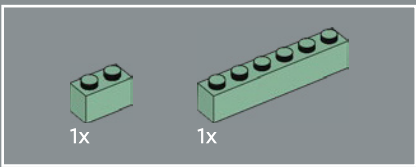
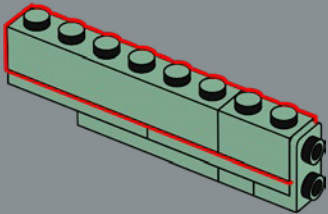

199

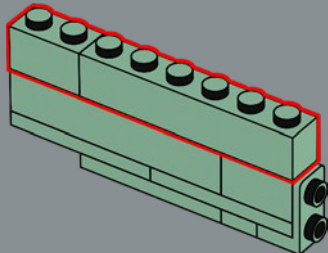

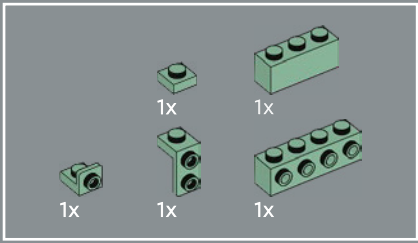

200

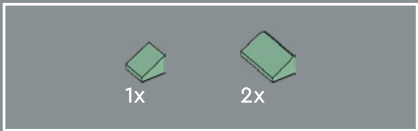
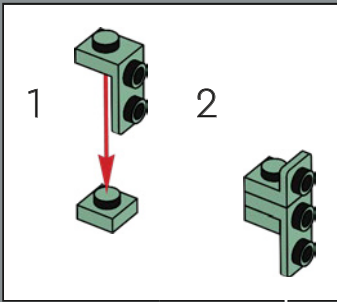
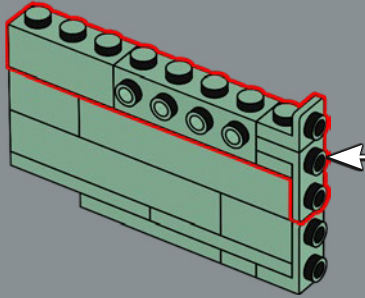

201

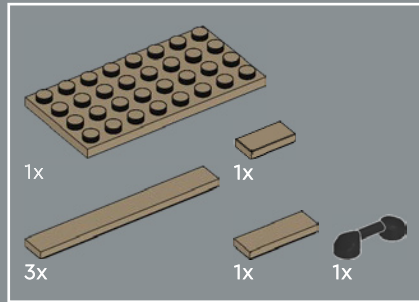
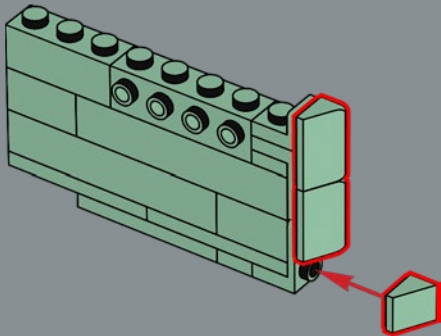

202

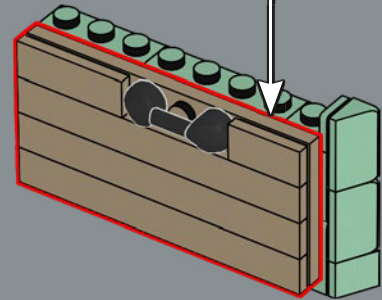
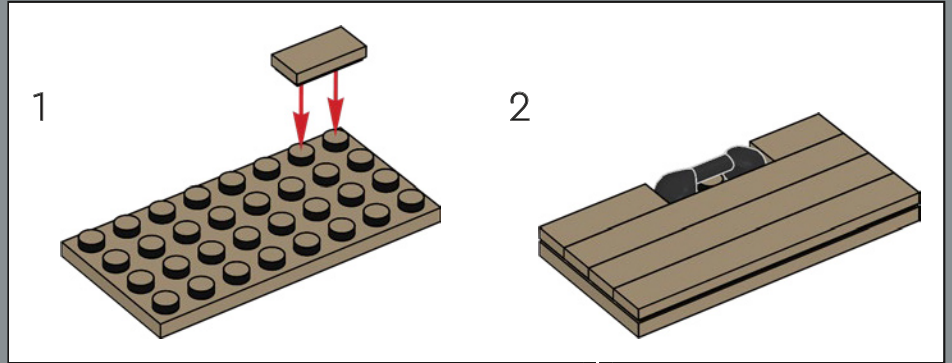

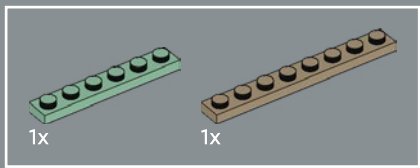

203

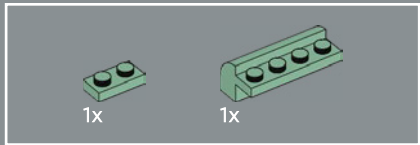
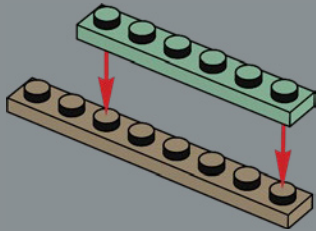

204

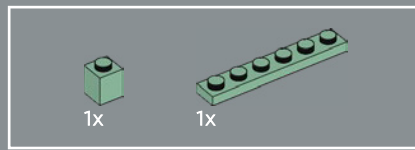
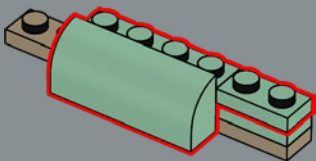

205

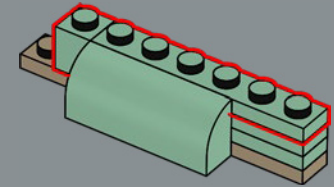

206

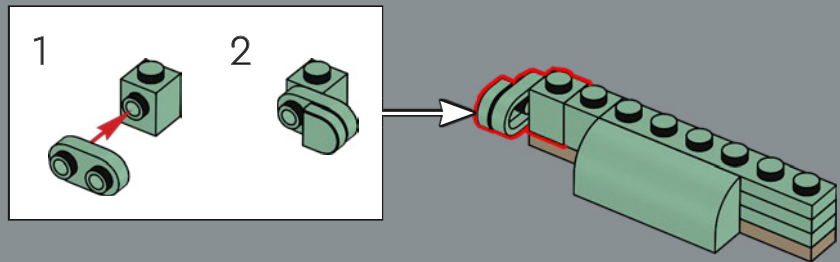

207

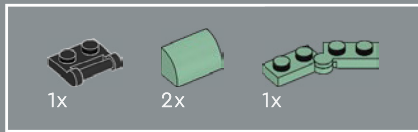
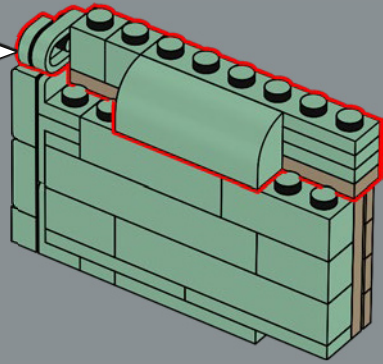

208

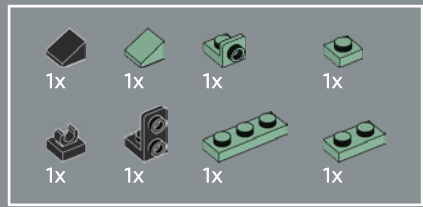
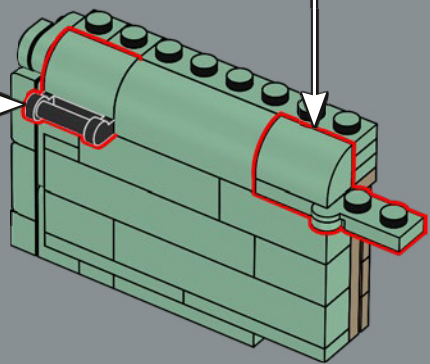
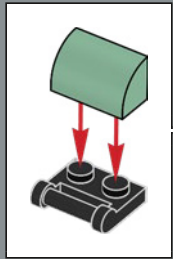
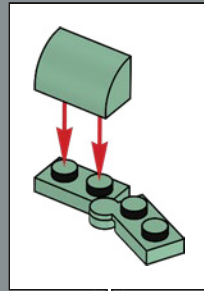

209

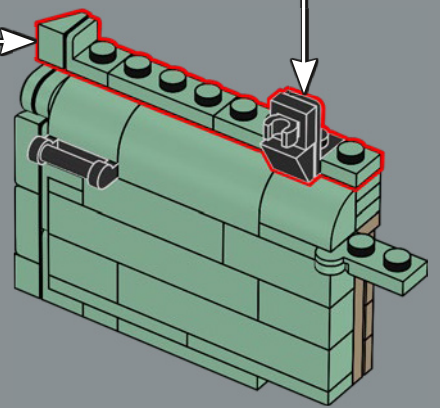
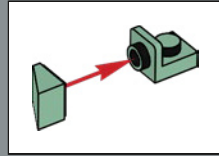
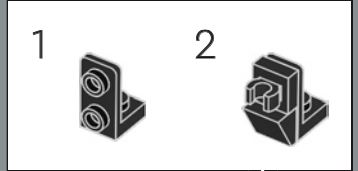

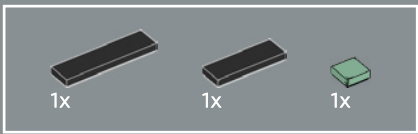

210

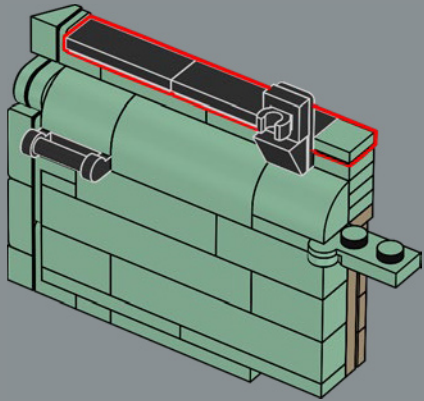

211

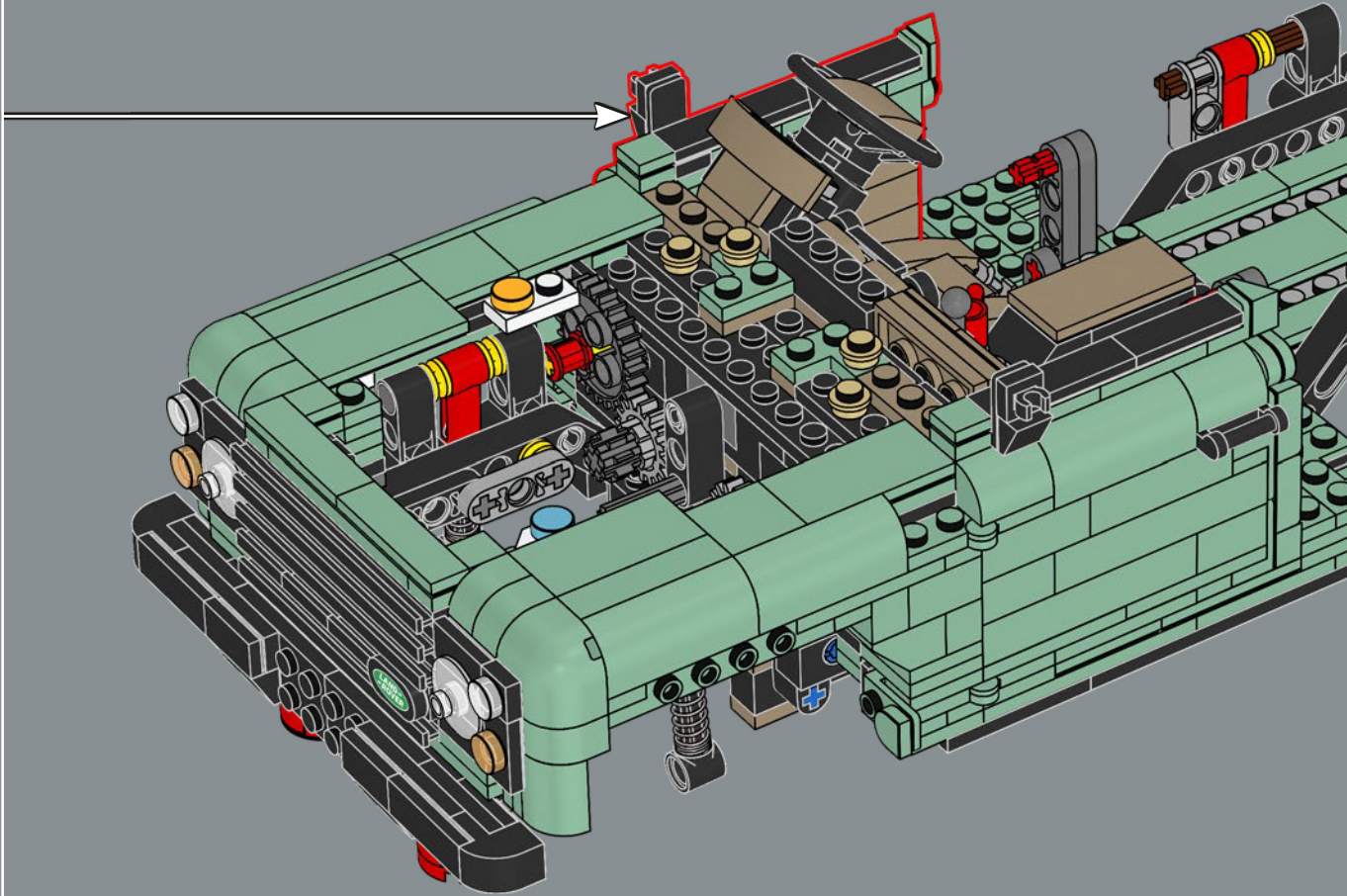

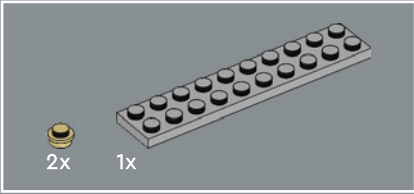
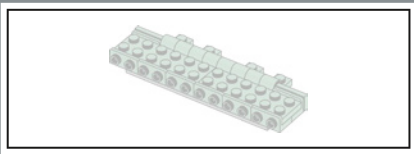

212

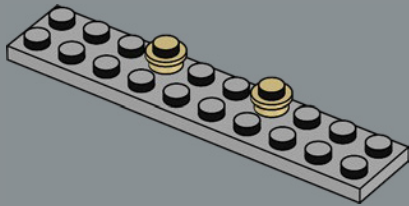

213

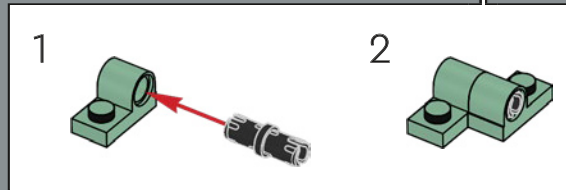
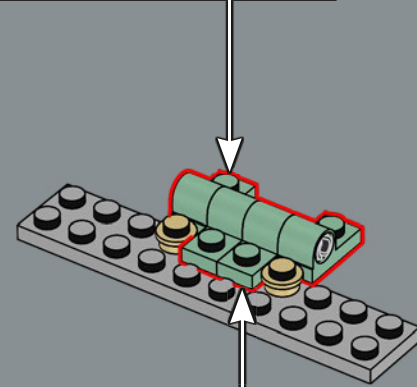
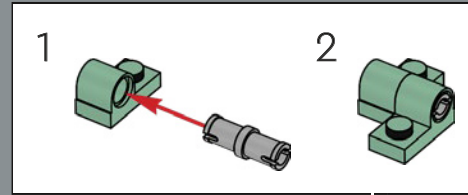

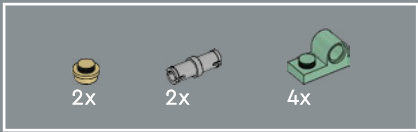

214

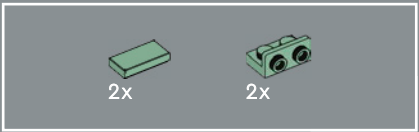
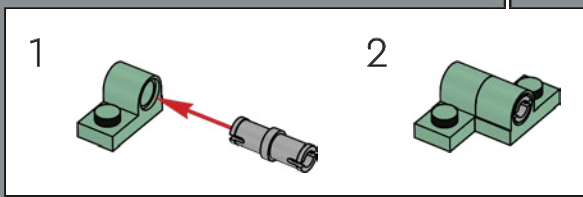
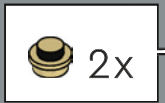
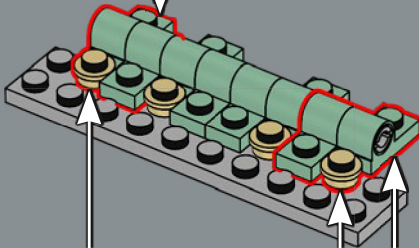
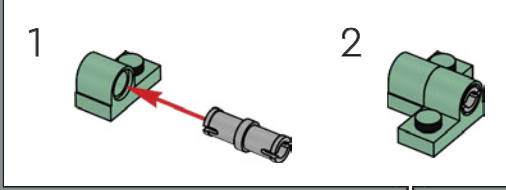

215

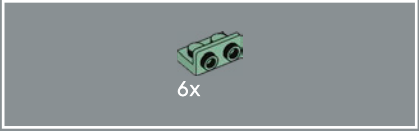
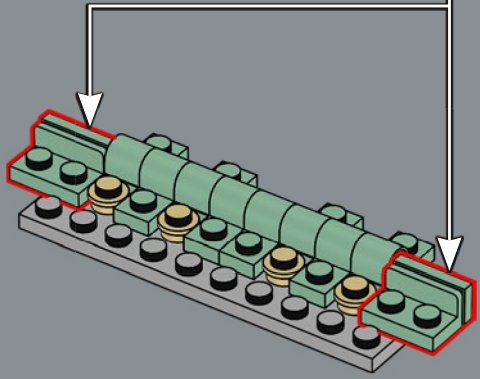
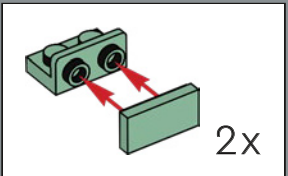

216

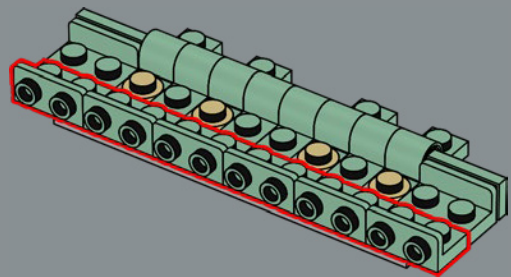

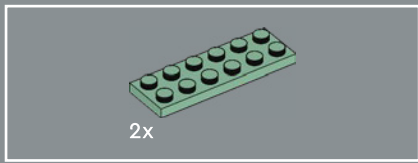

217

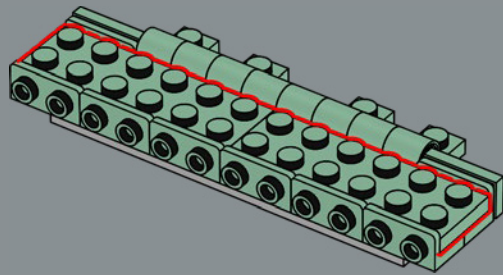

218

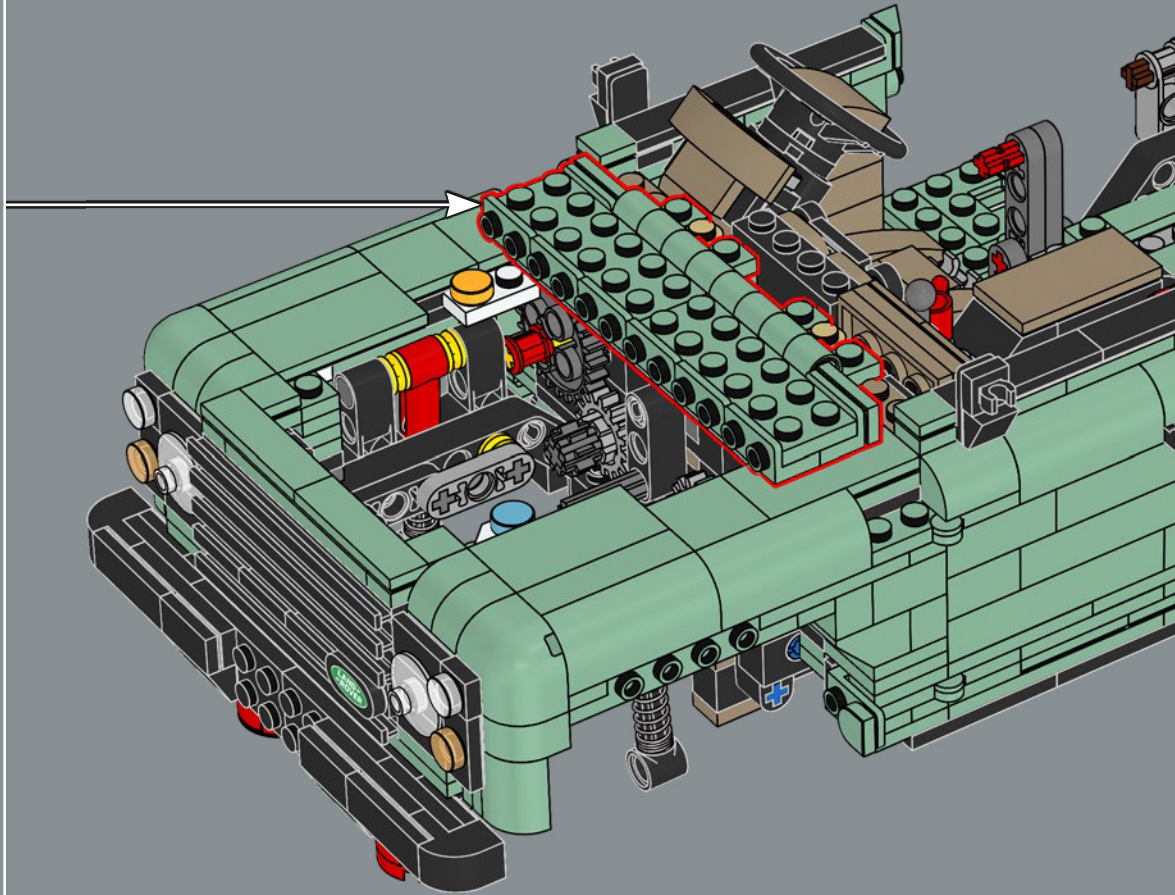

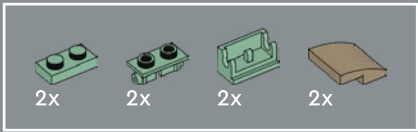

219

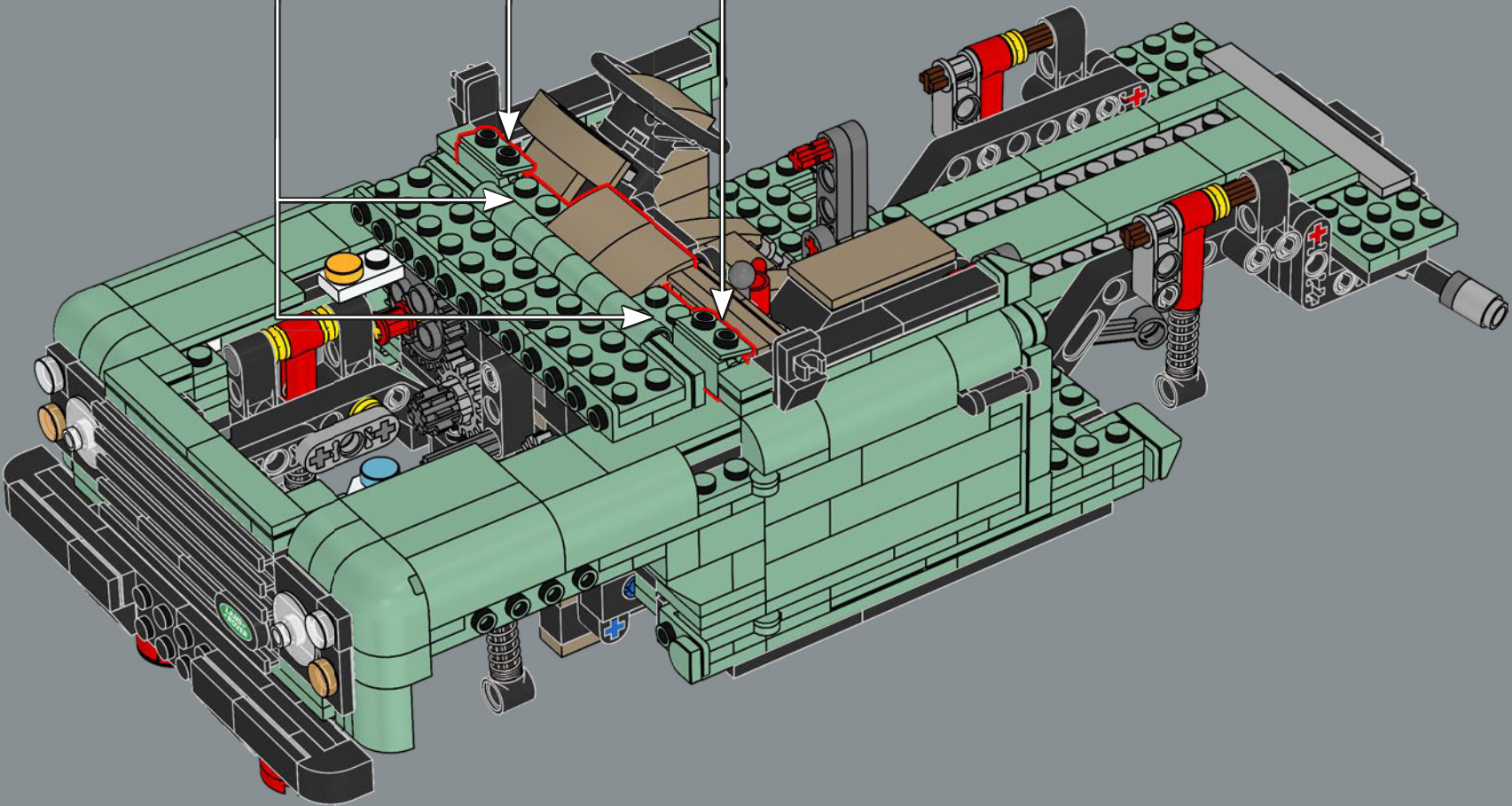
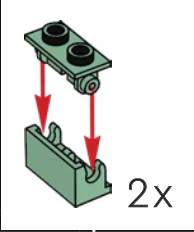
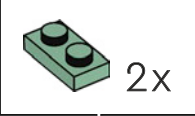

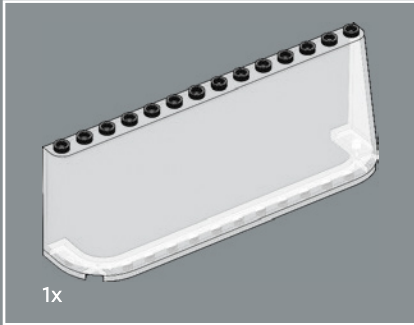
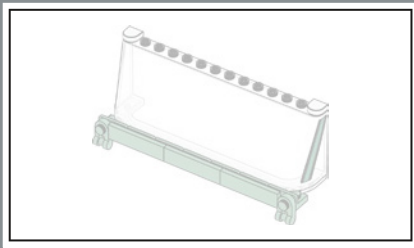

1x

220

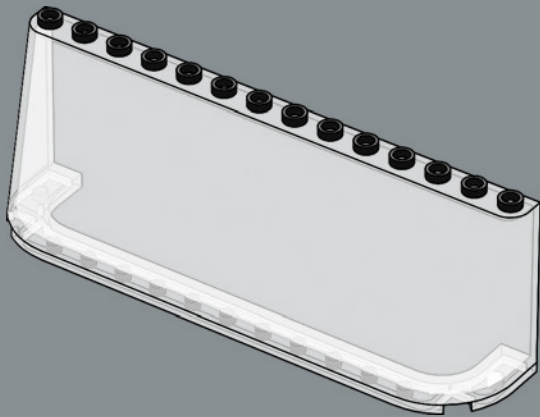

7x

221

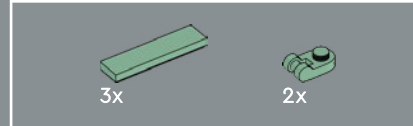
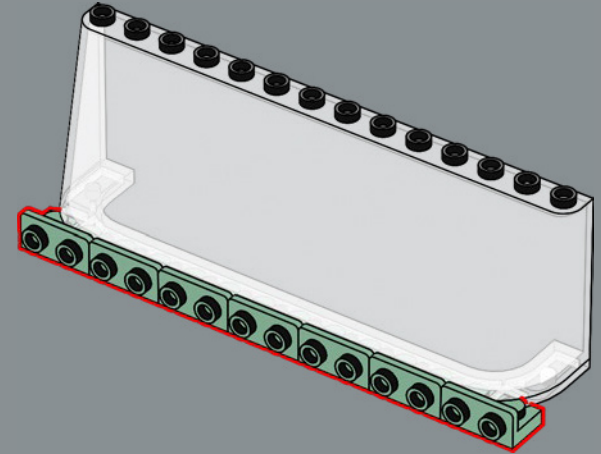

3x

2x

222

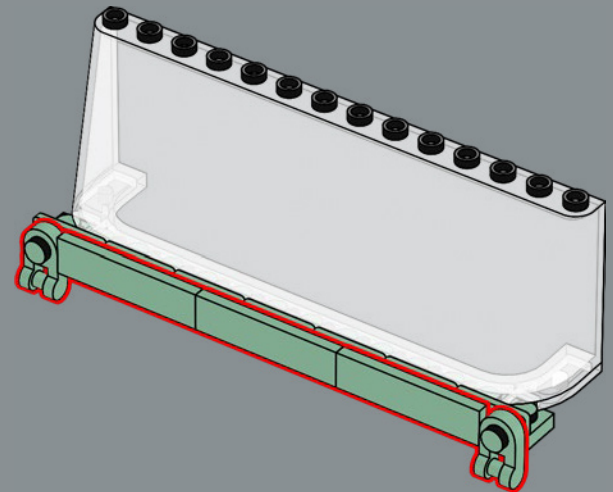

223

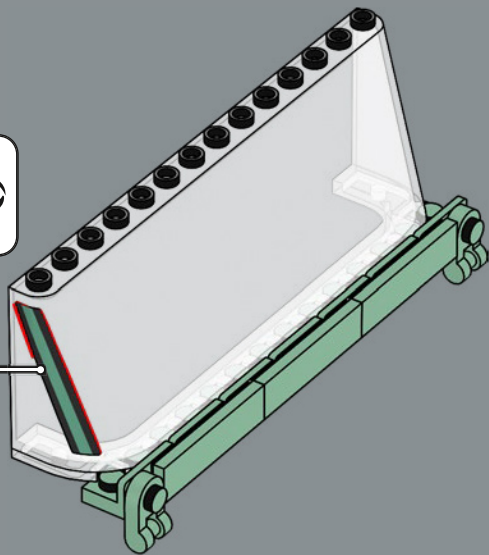

224

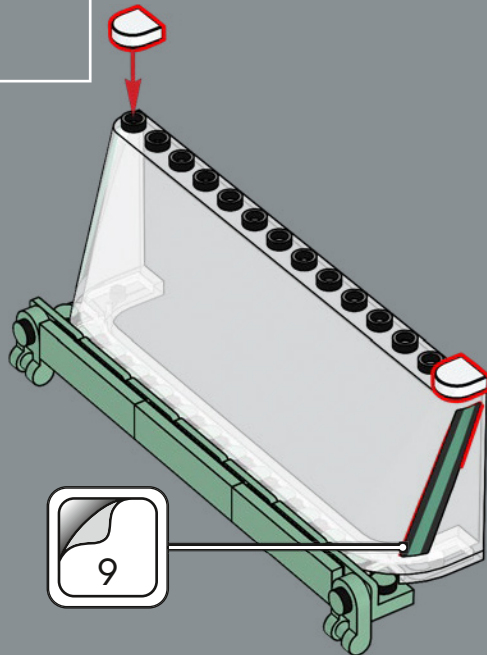

225

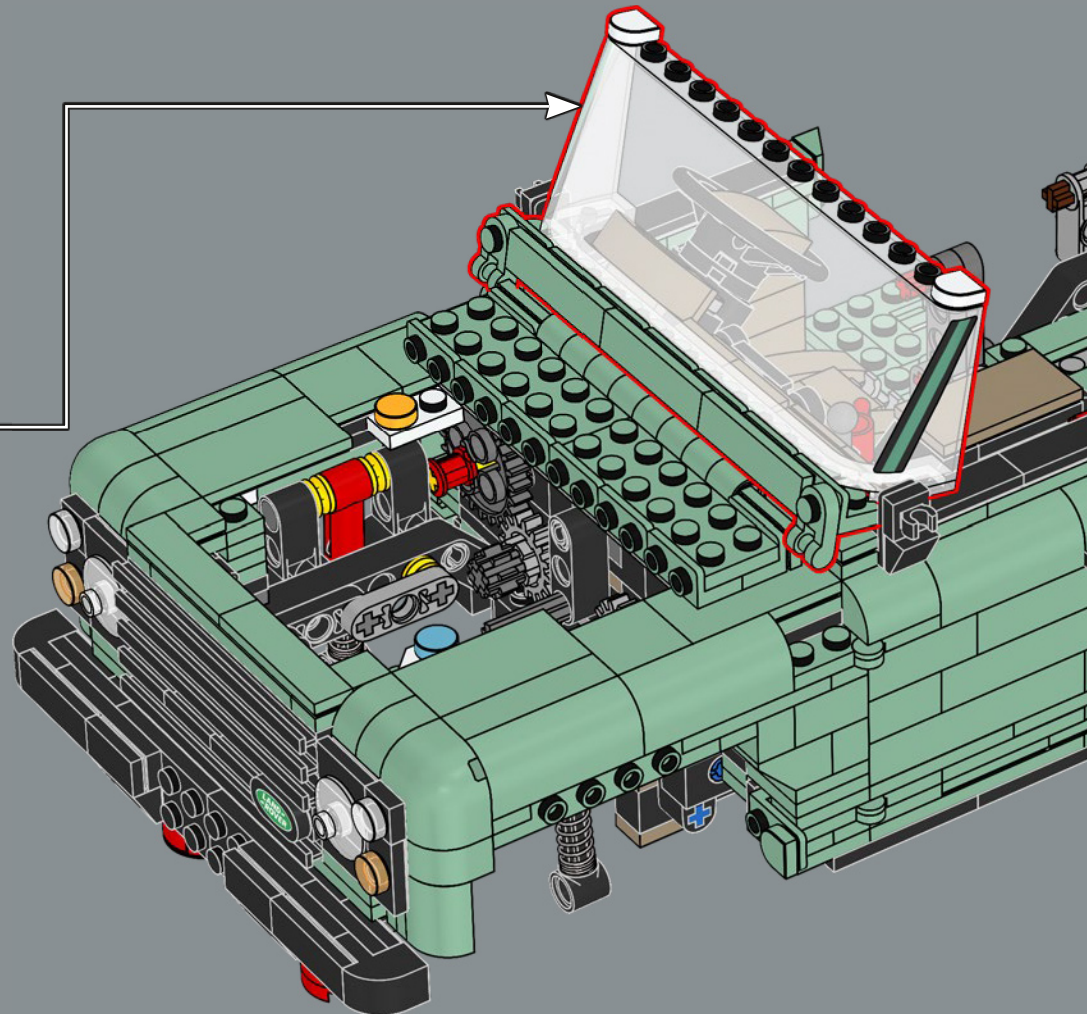



226

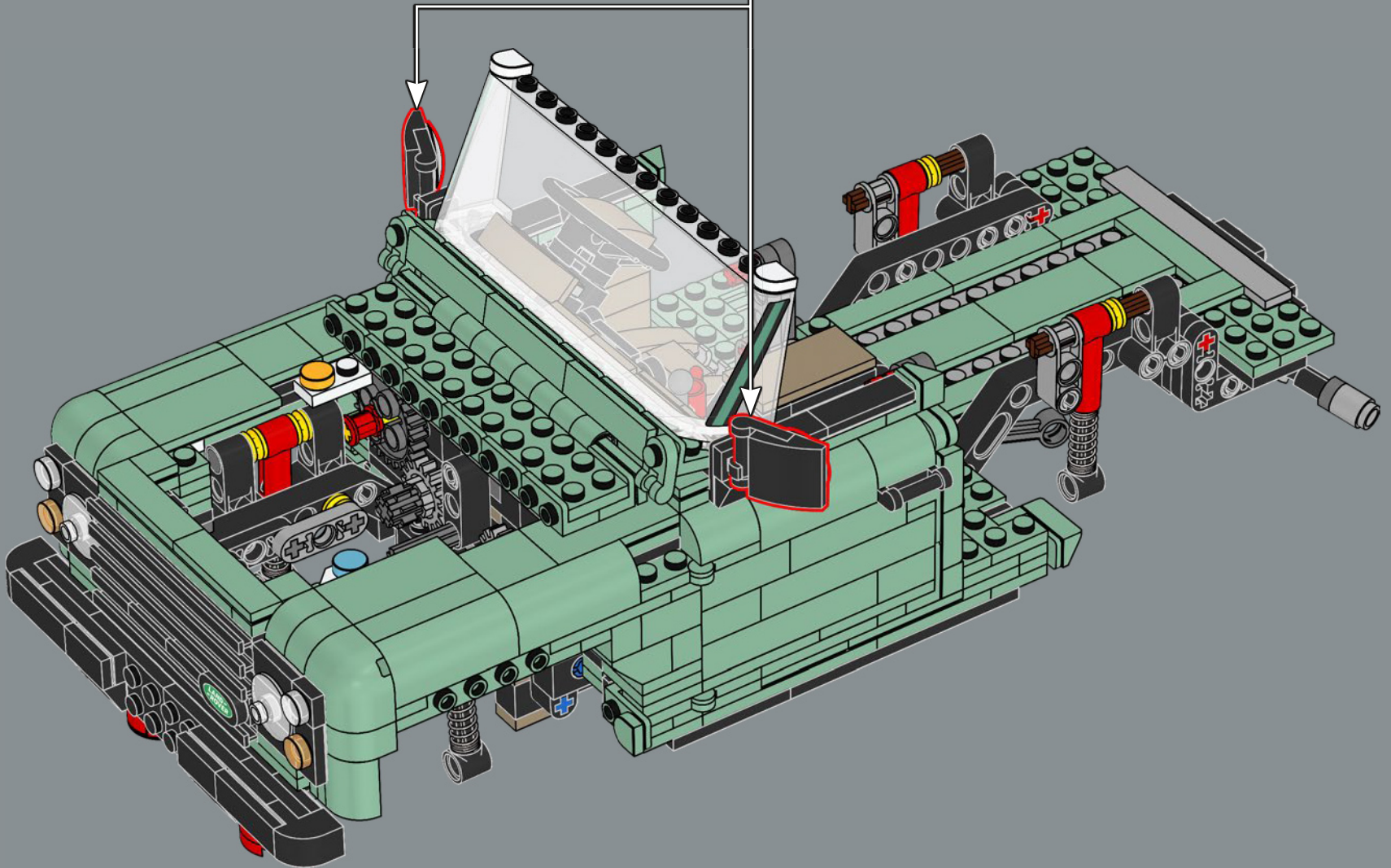
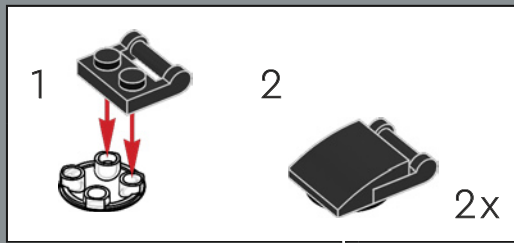

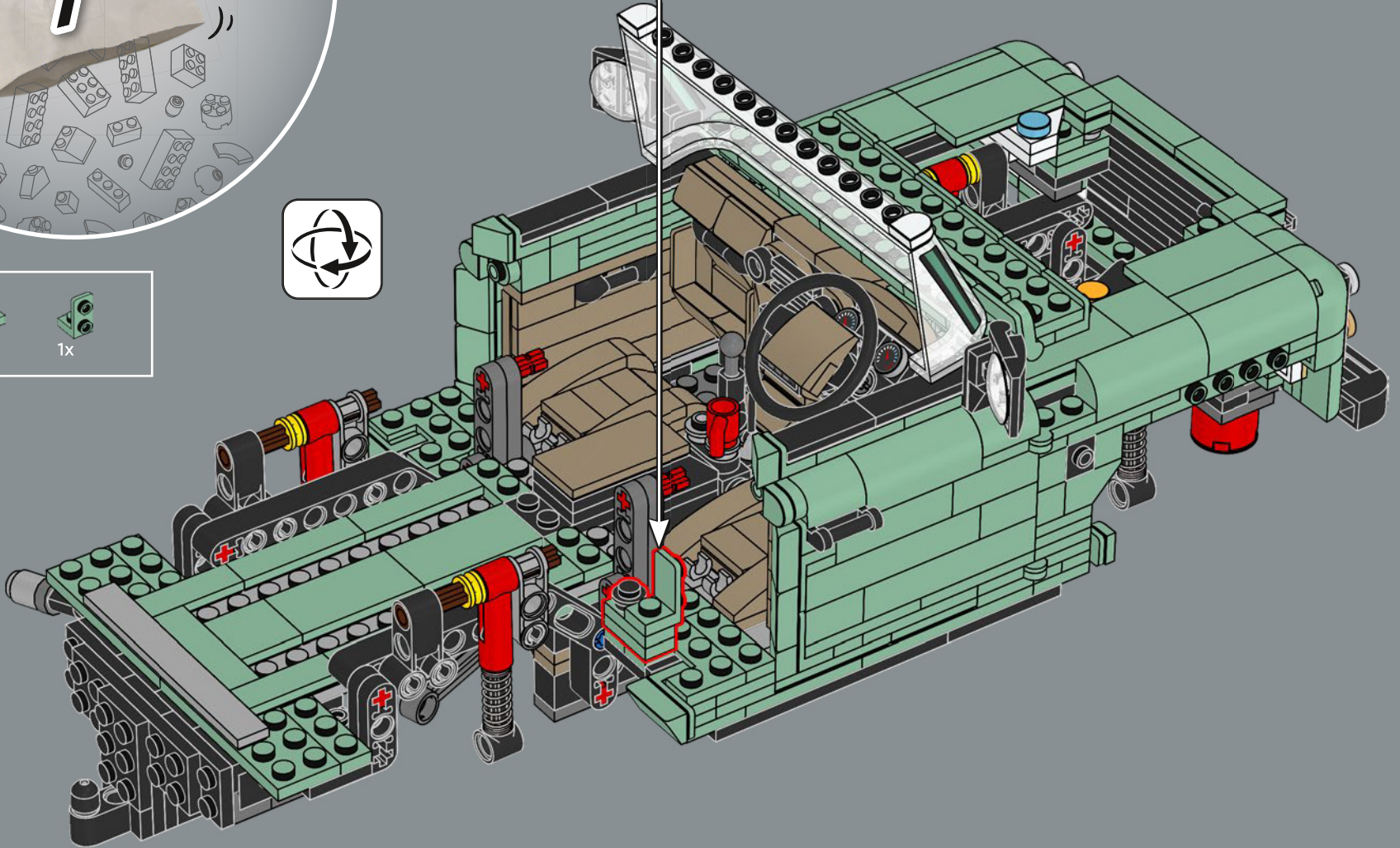
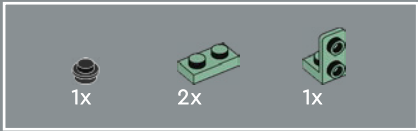
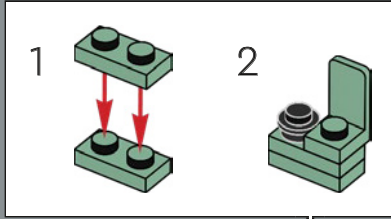

227

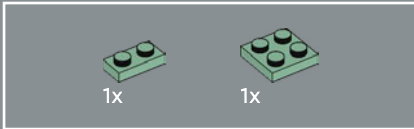
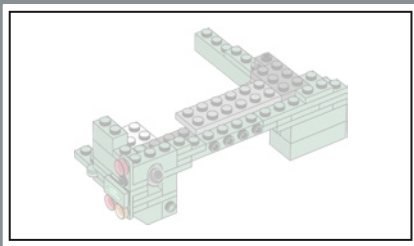

228

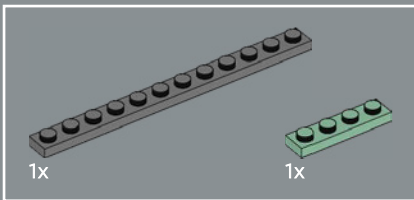
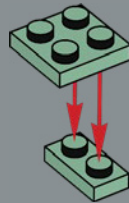

229

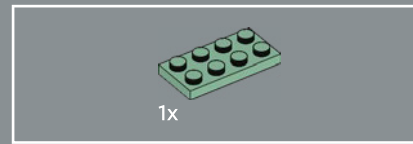
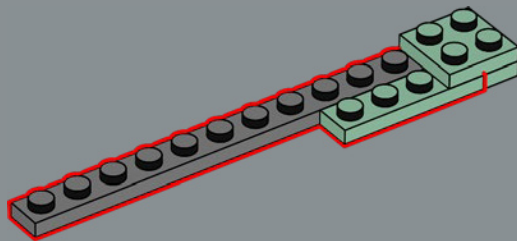

230

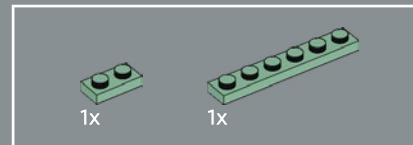
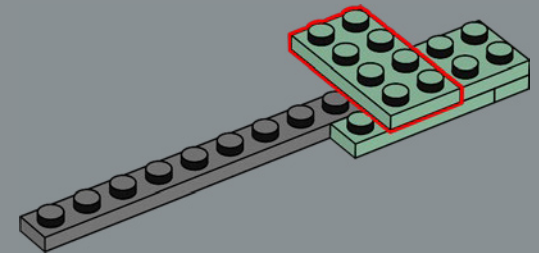

231

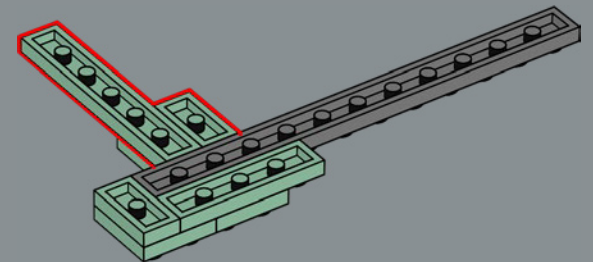

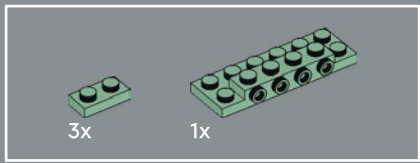

232

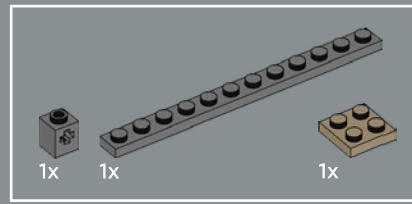
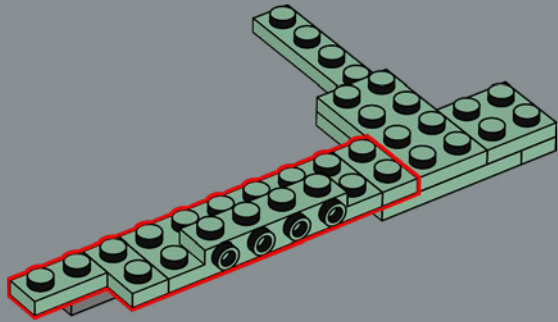

233

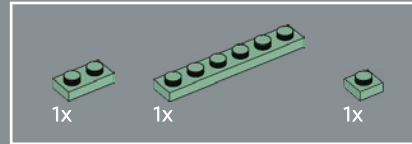
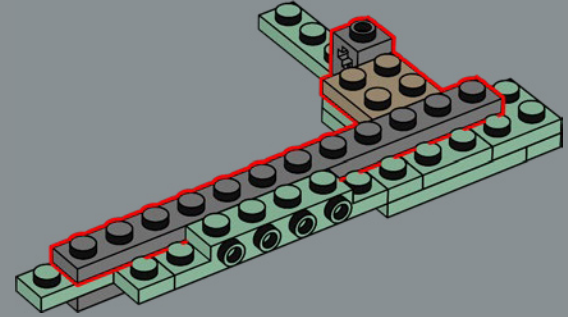

234

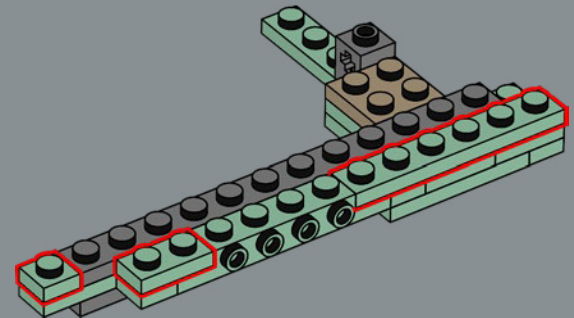

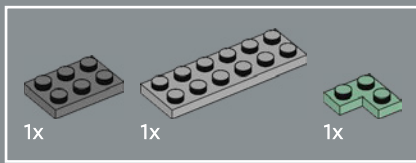

235

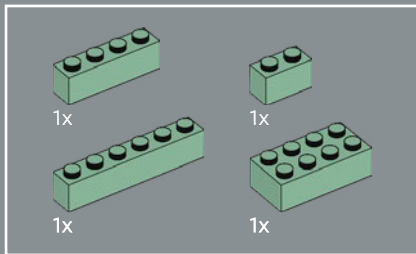
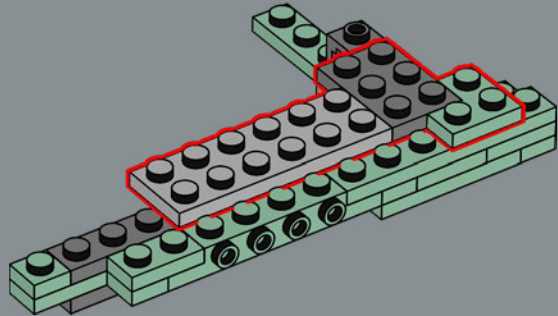

236

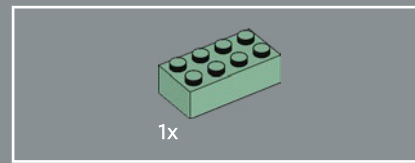
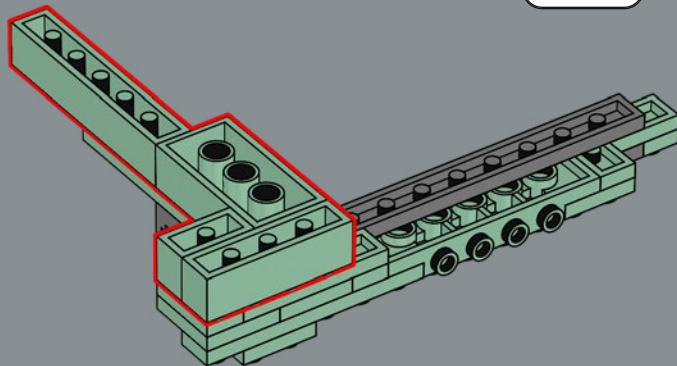

237

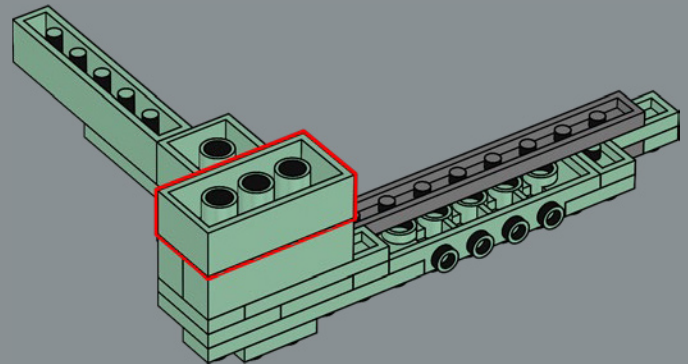

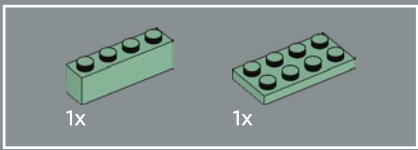

238

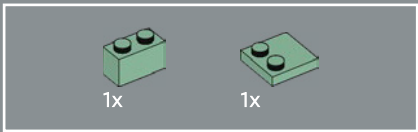
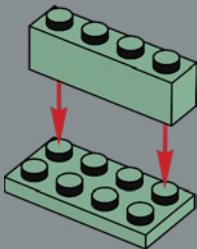

239

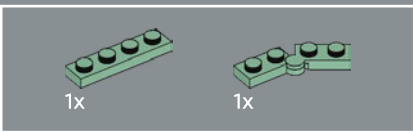
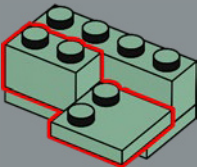

240

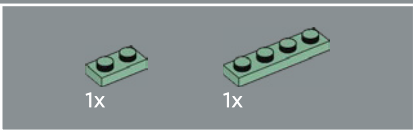
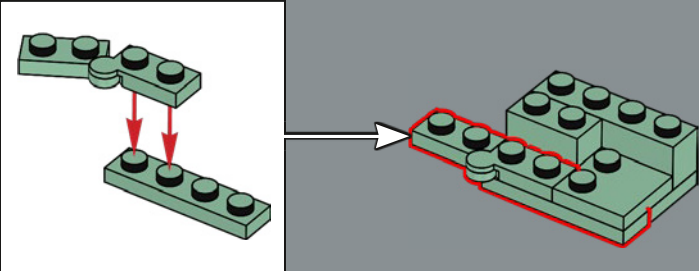

241

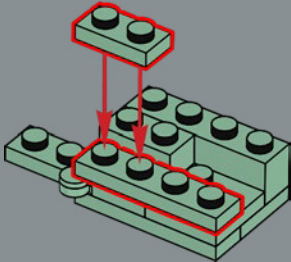

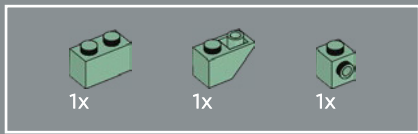

242

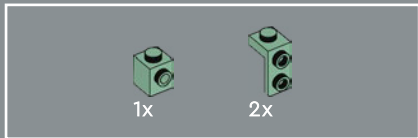
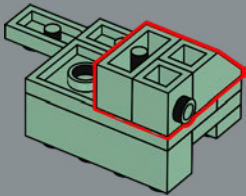

243

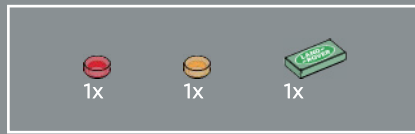
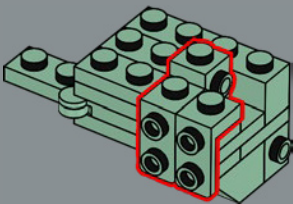

244

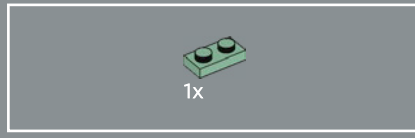
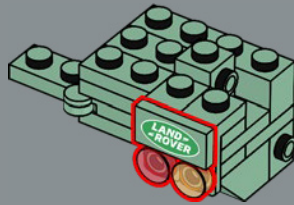

245

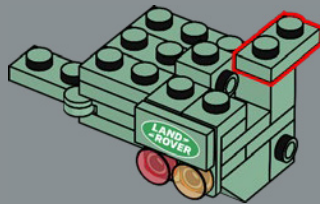

246

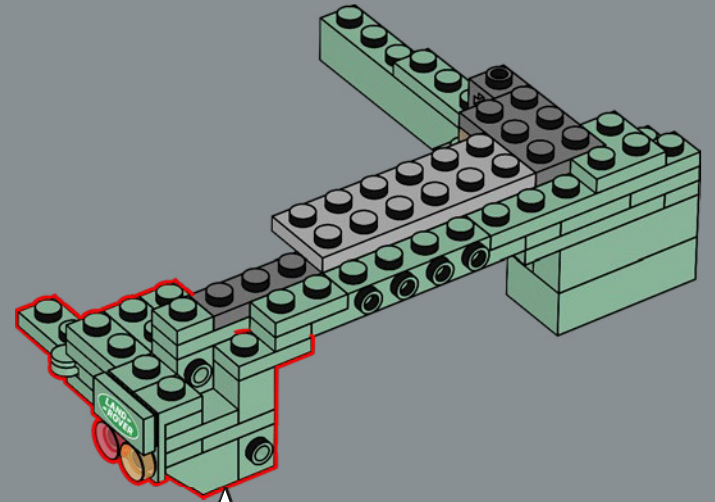

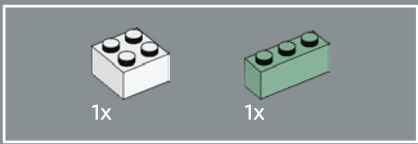

247

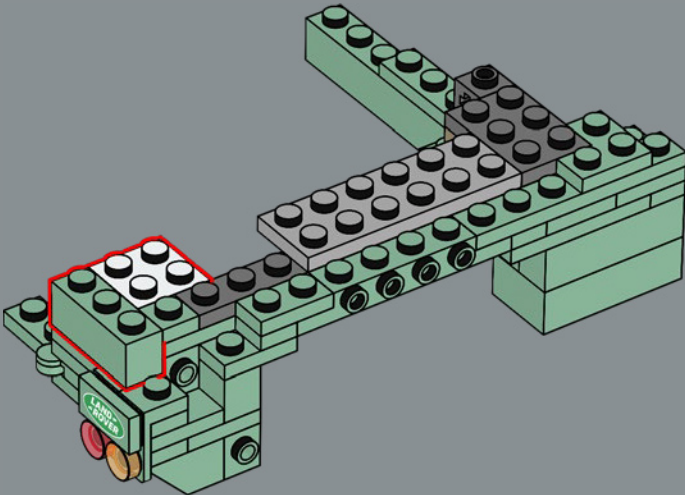

248

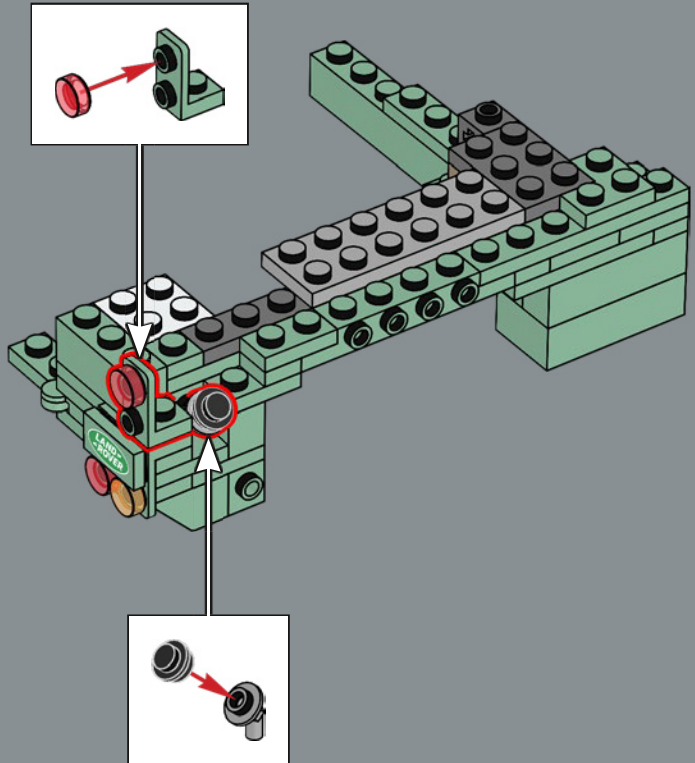

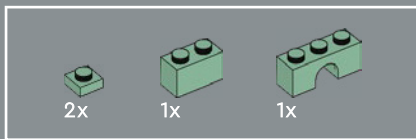

249

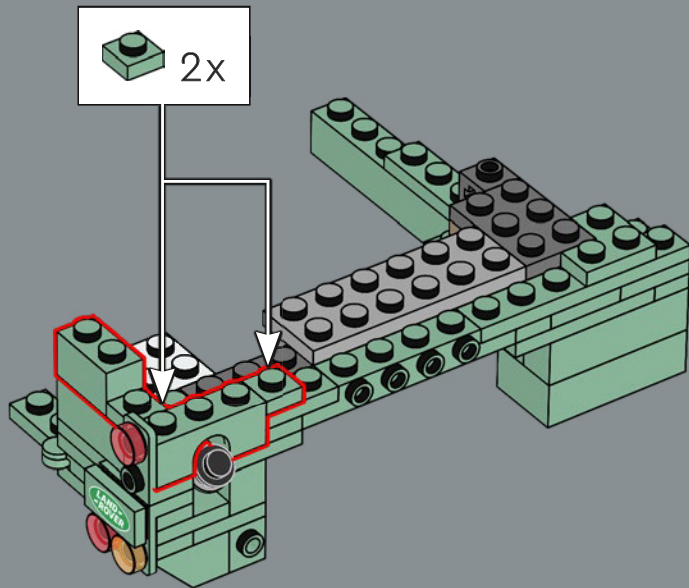

250

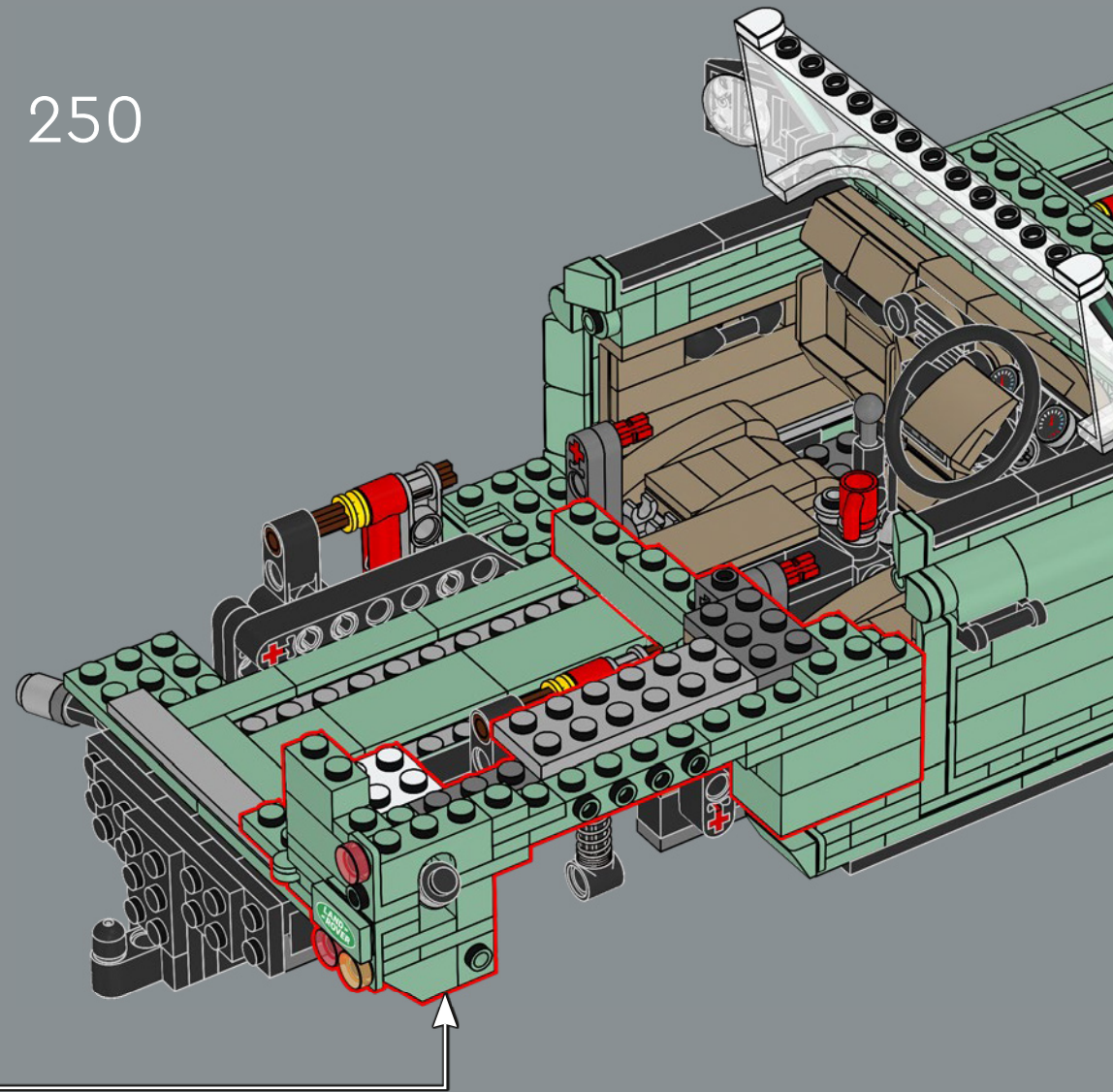

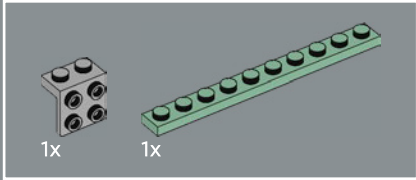
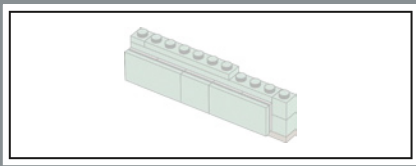

251

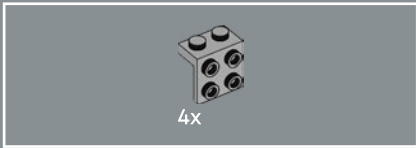
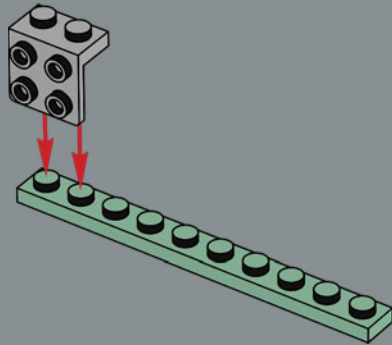

252

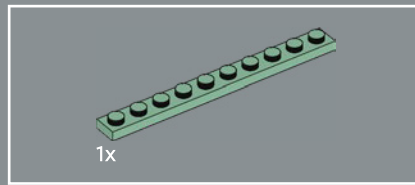
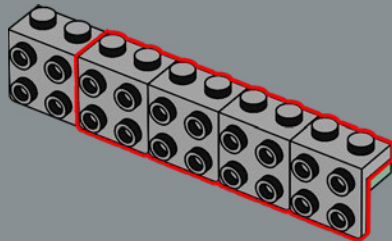

253

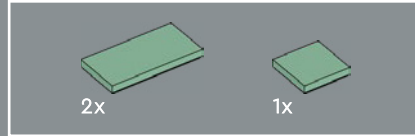
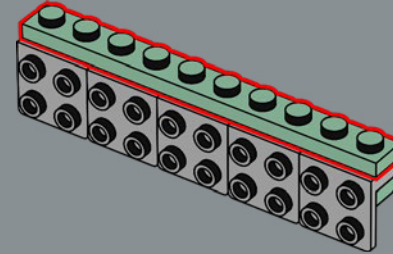

254

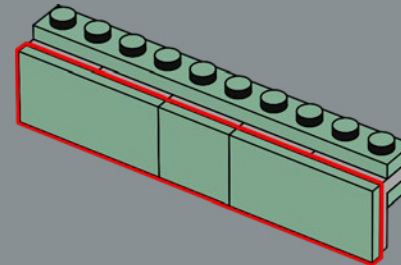

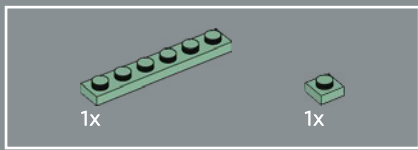

255

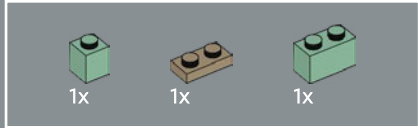
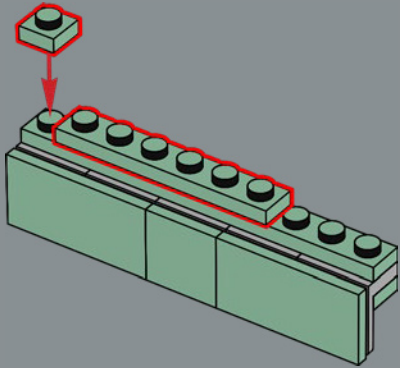

256

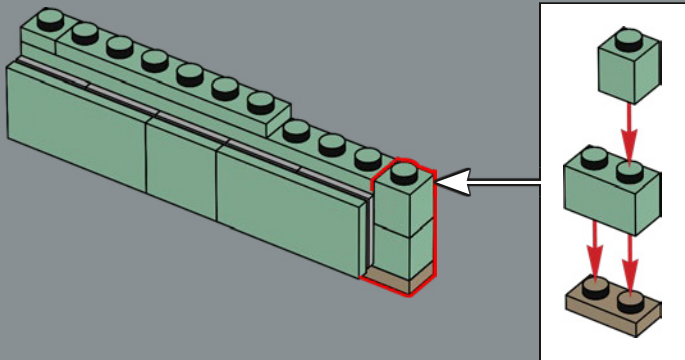

257

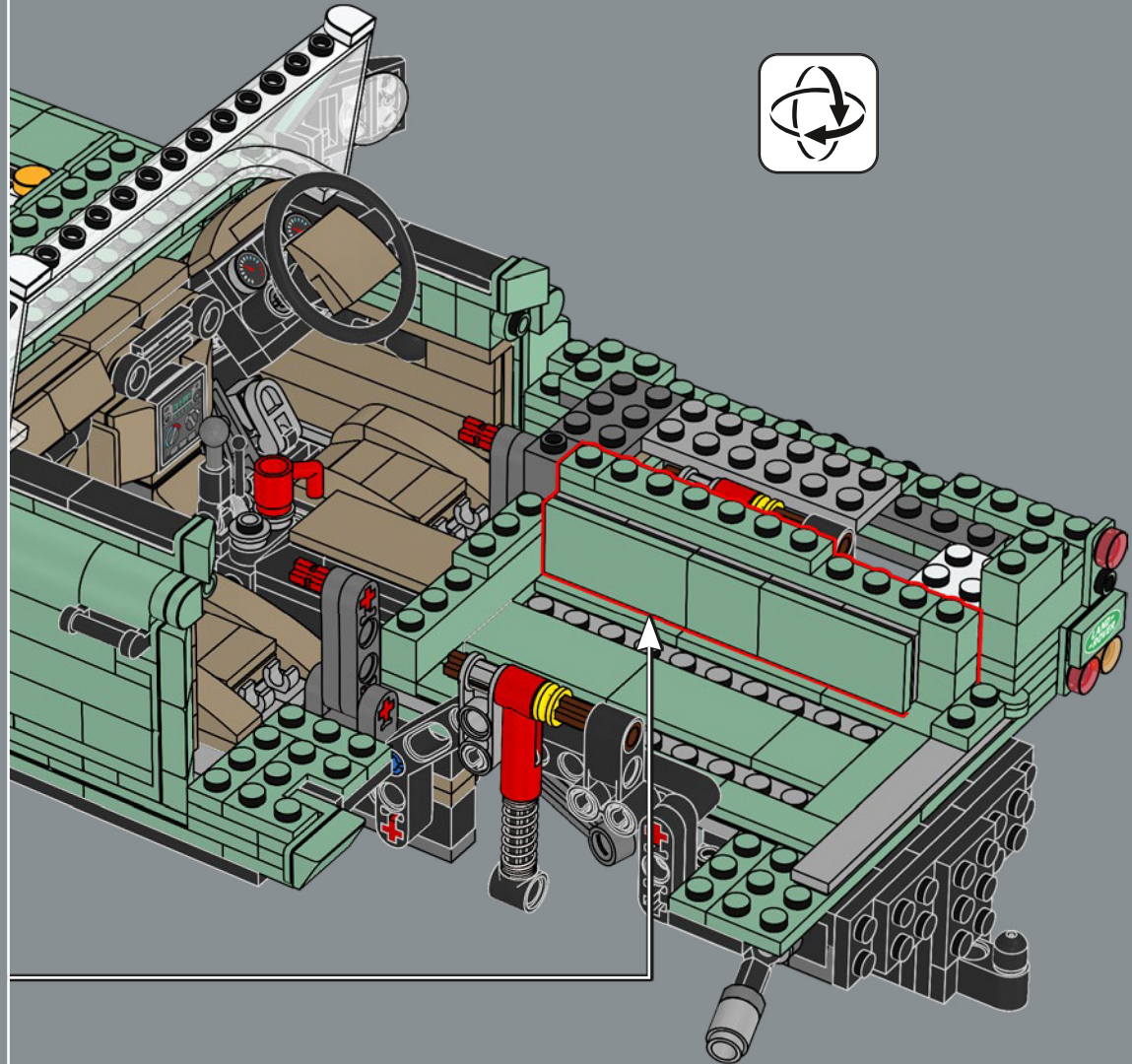

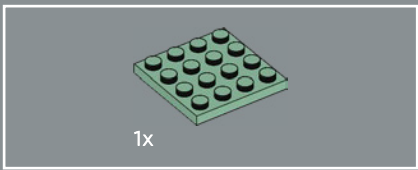

258

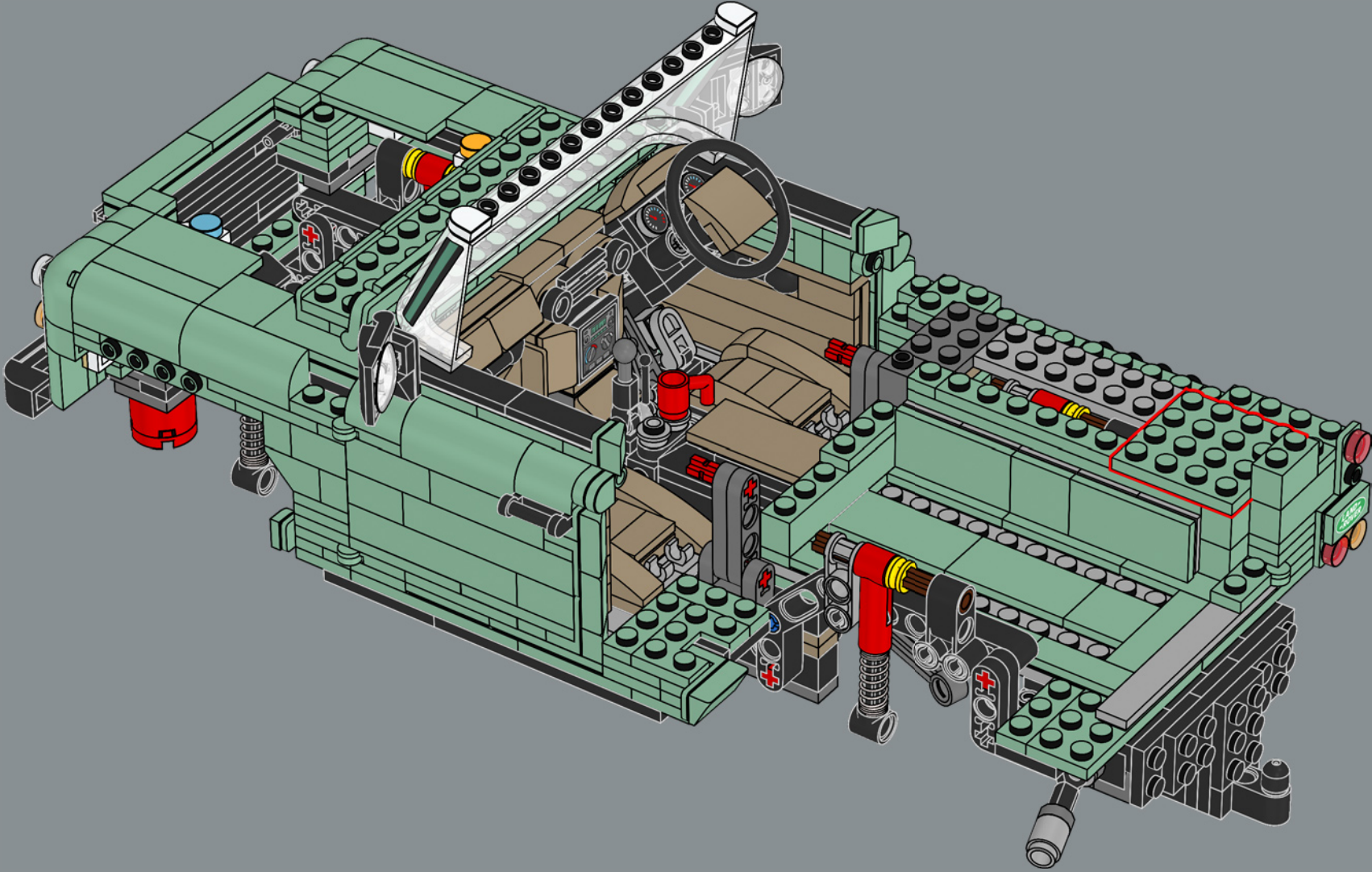

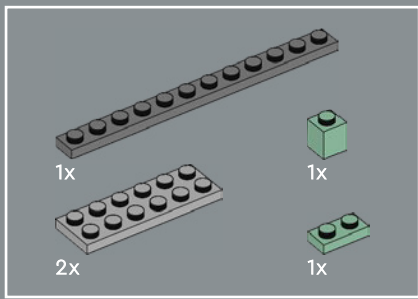

259

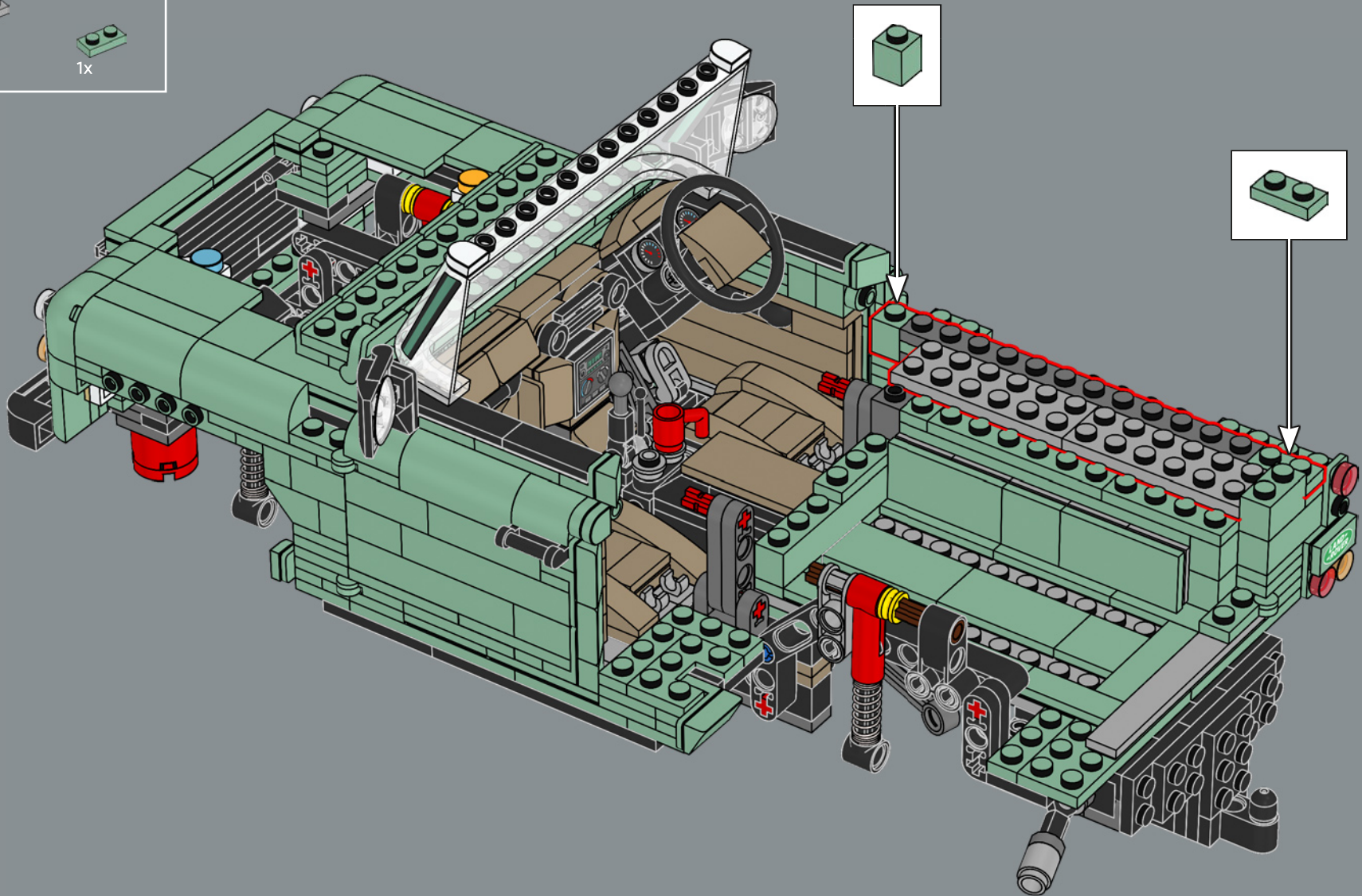

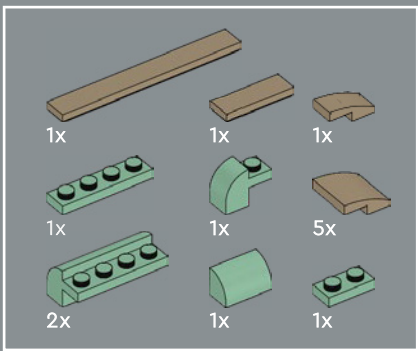

260

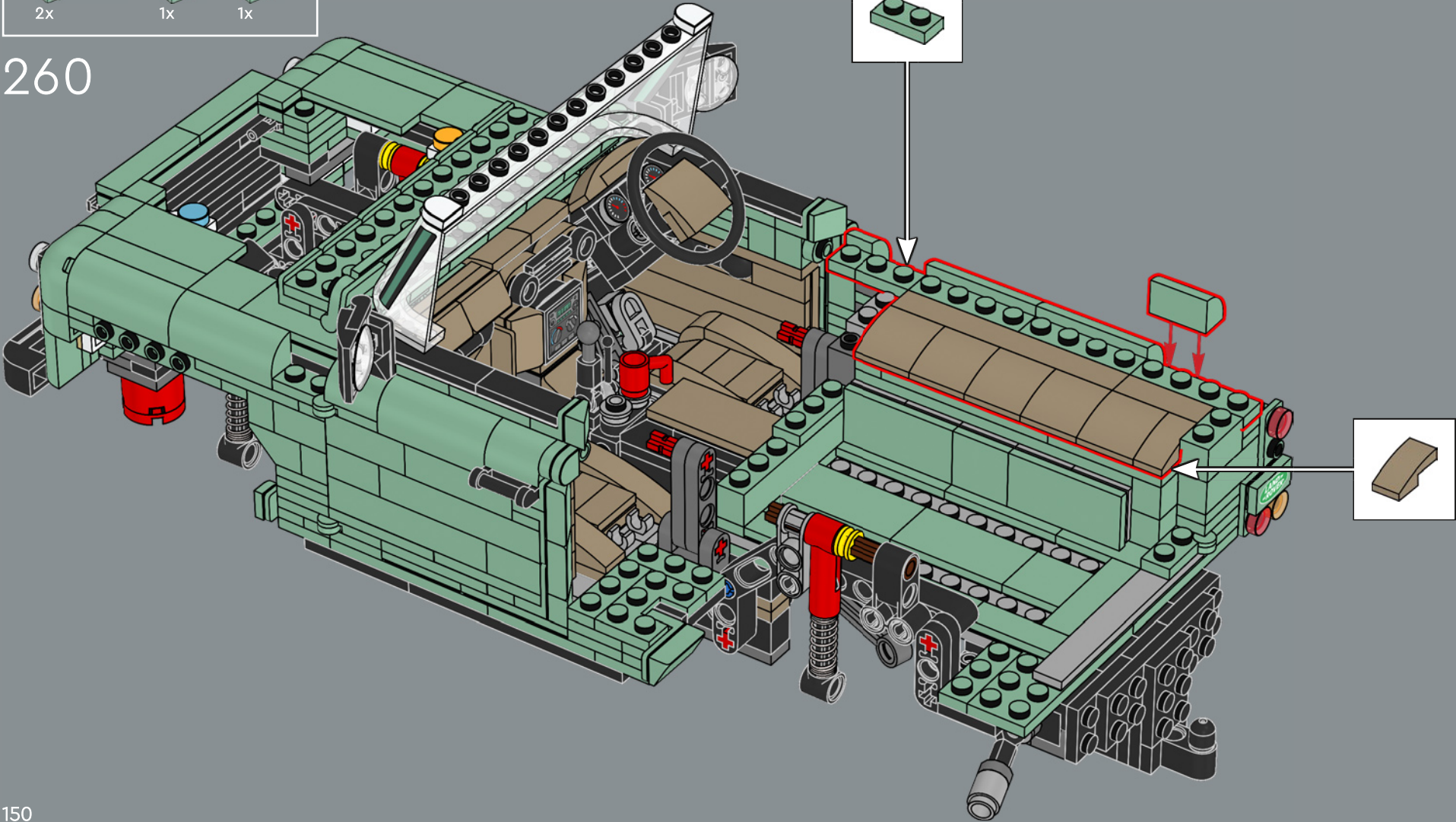

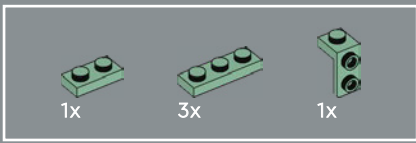

261

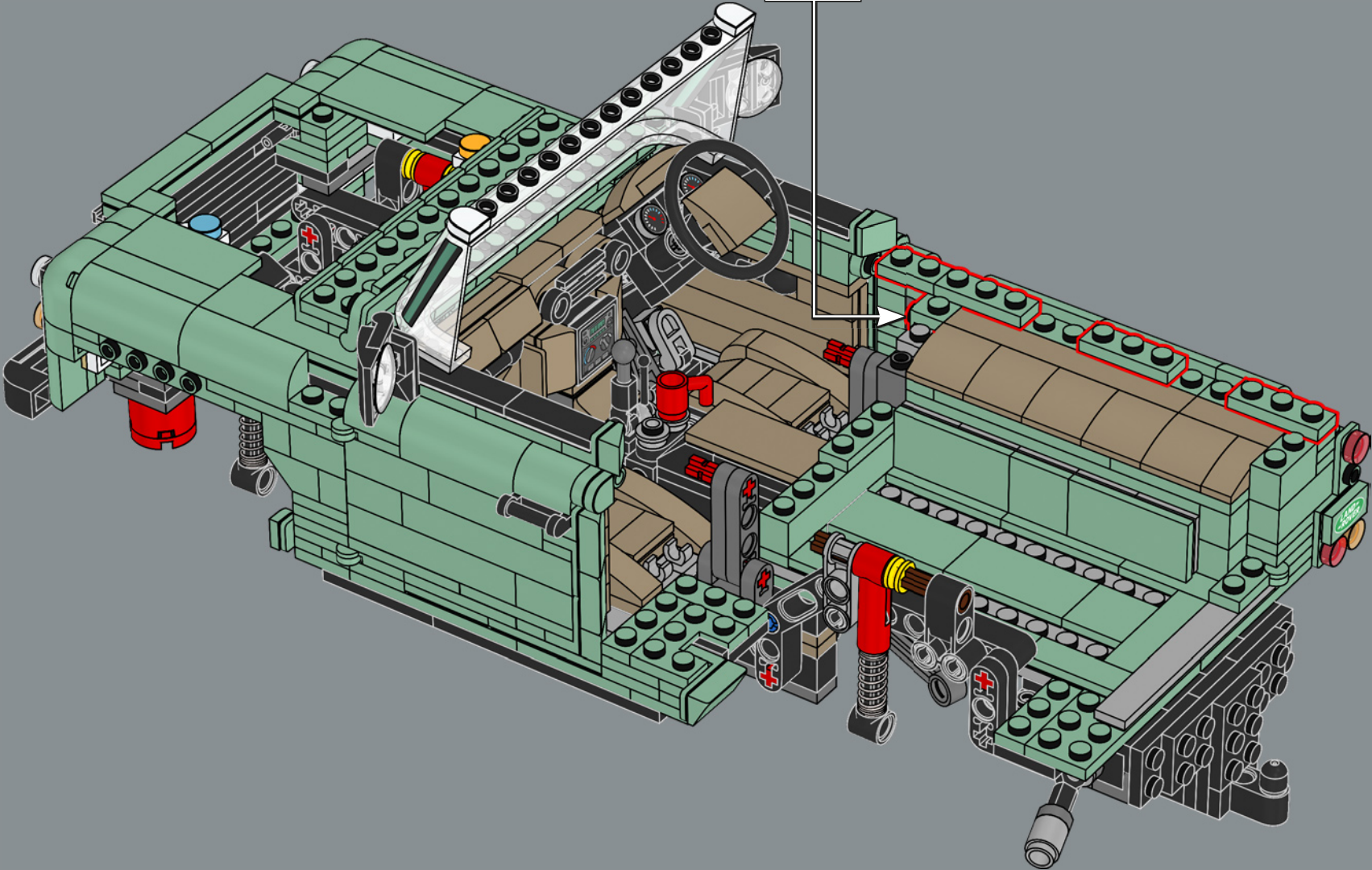

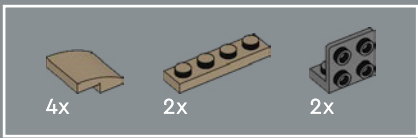

262

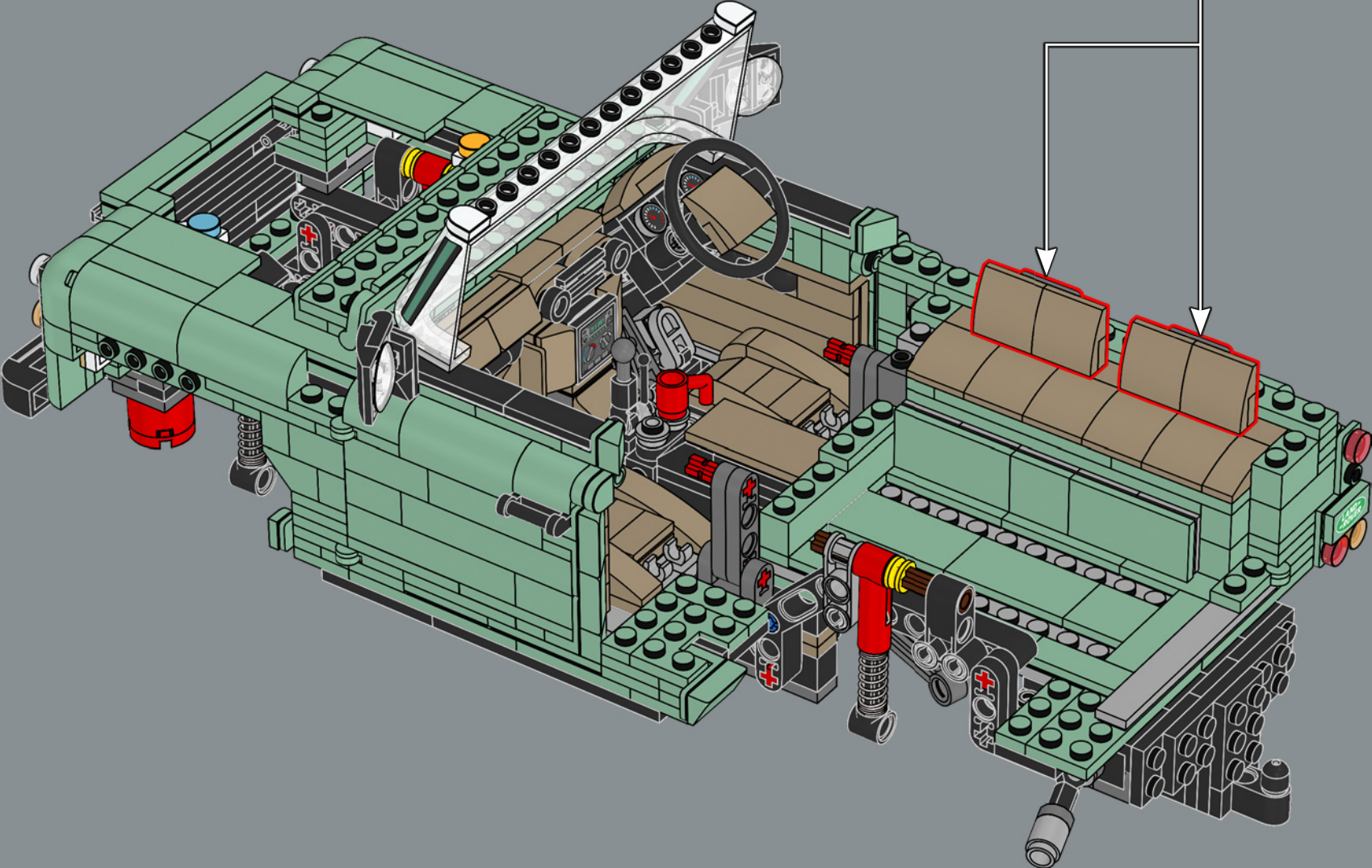
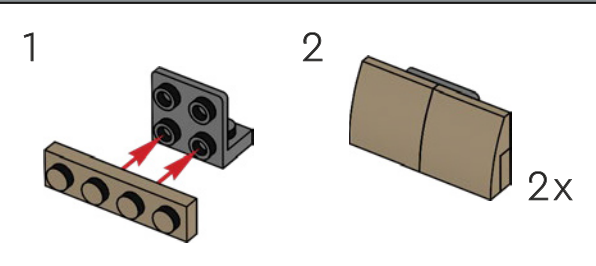

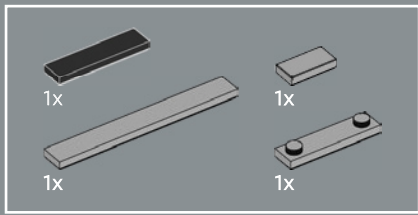

263

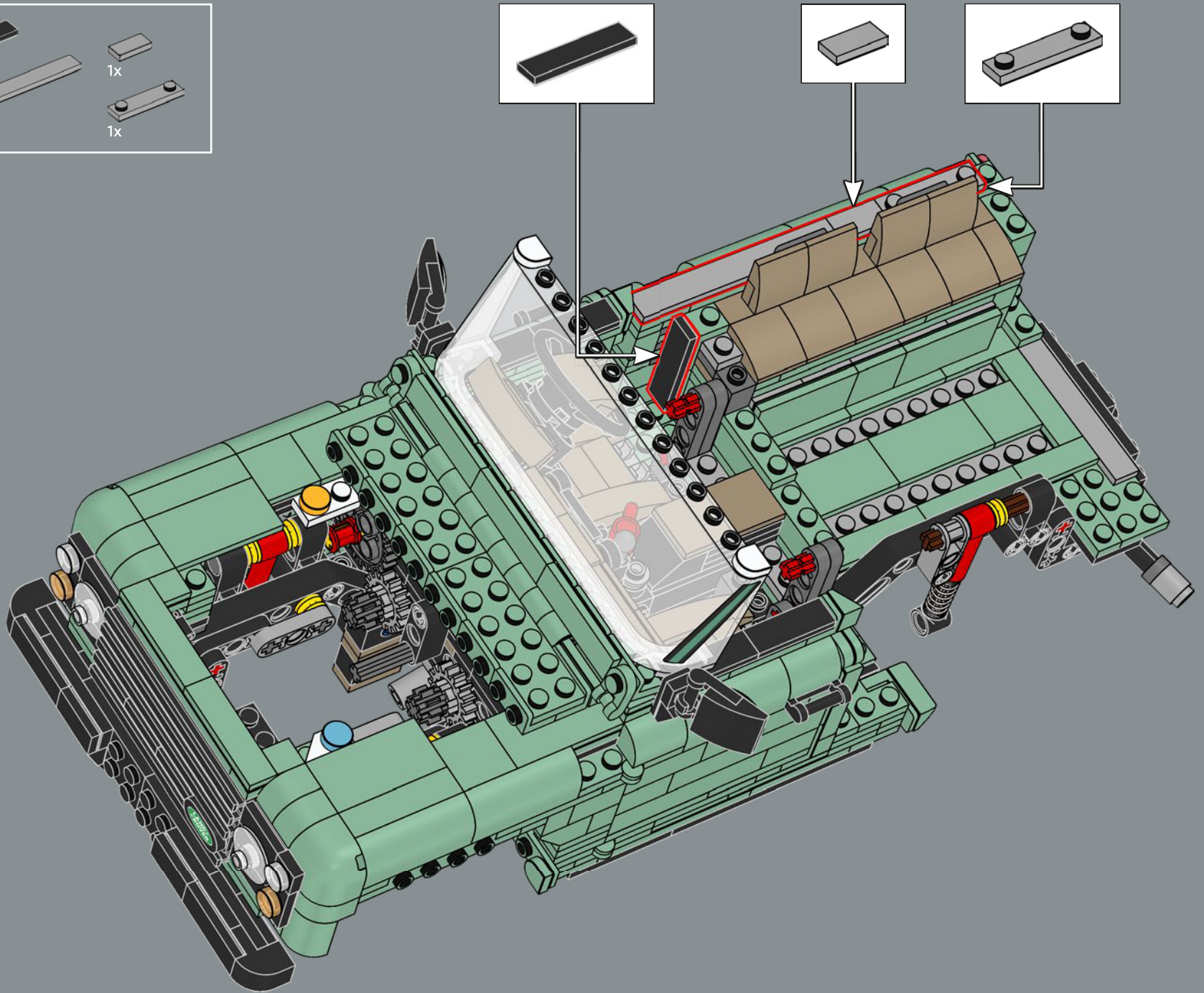

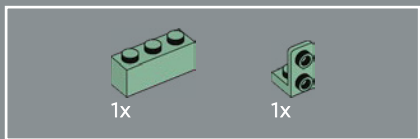

264

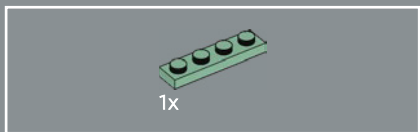
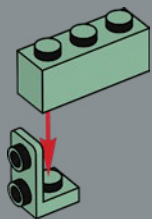

265

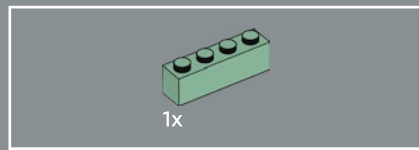
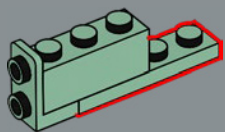

266

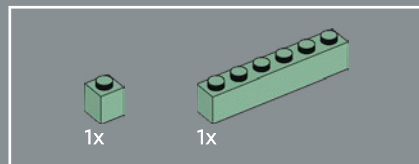
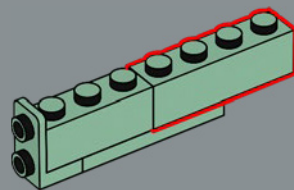

267

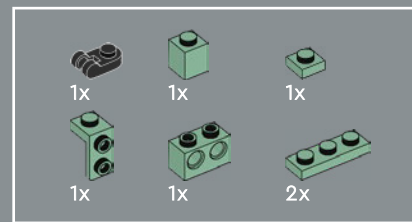
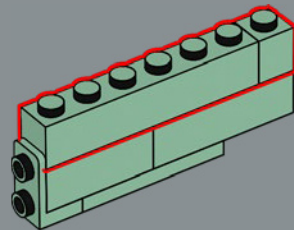

268

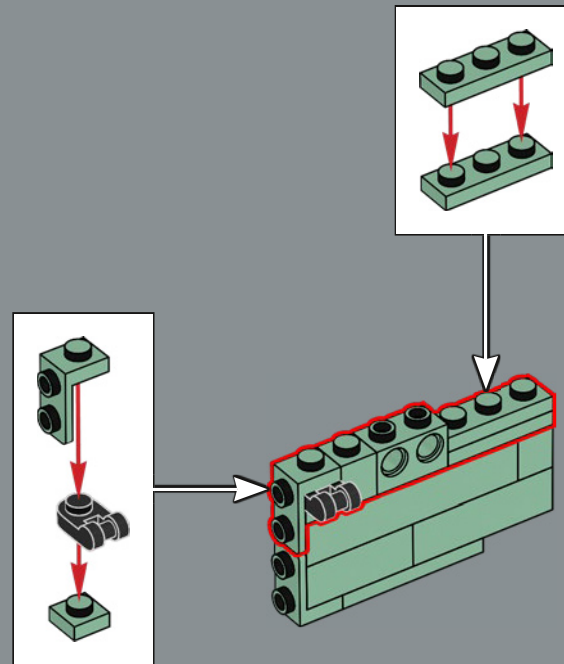

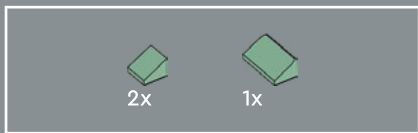

269

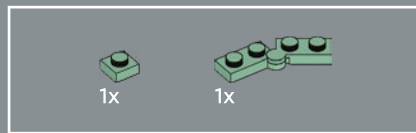
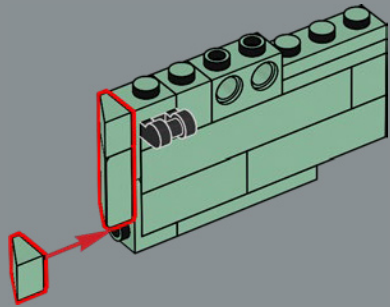

270

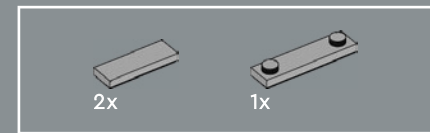
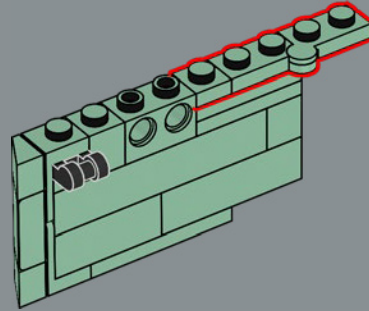

271

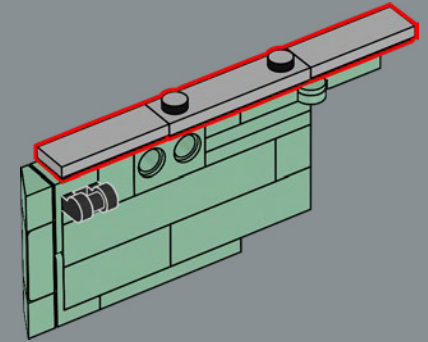

272

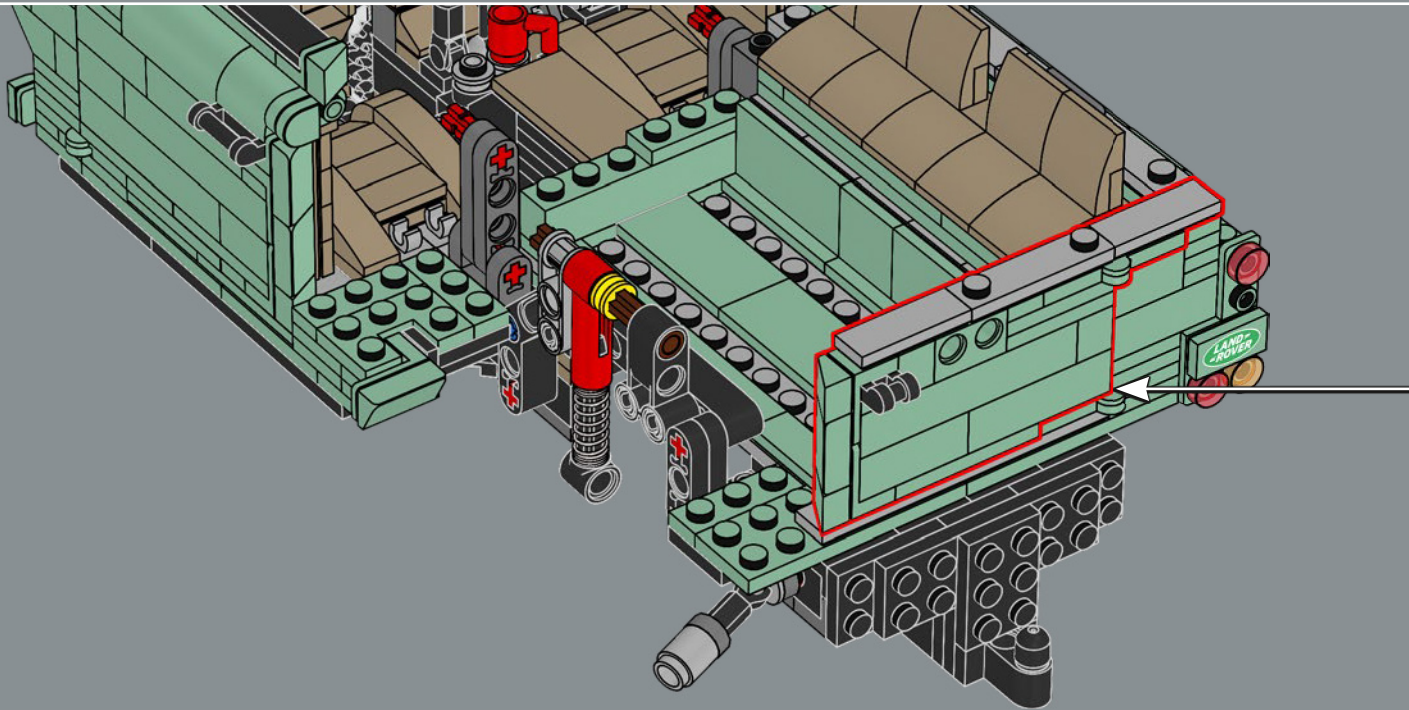

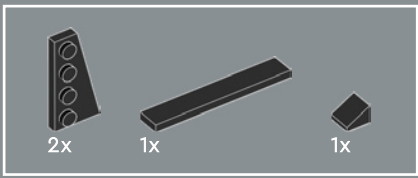

273

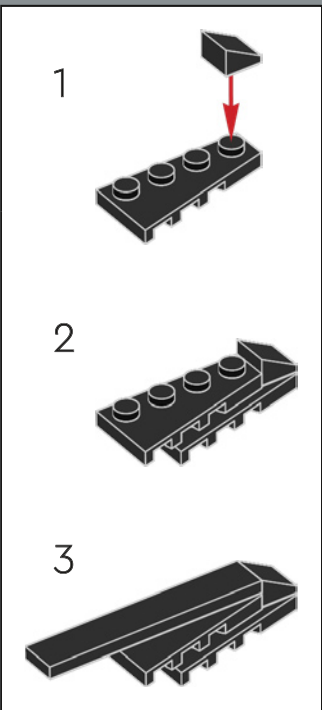
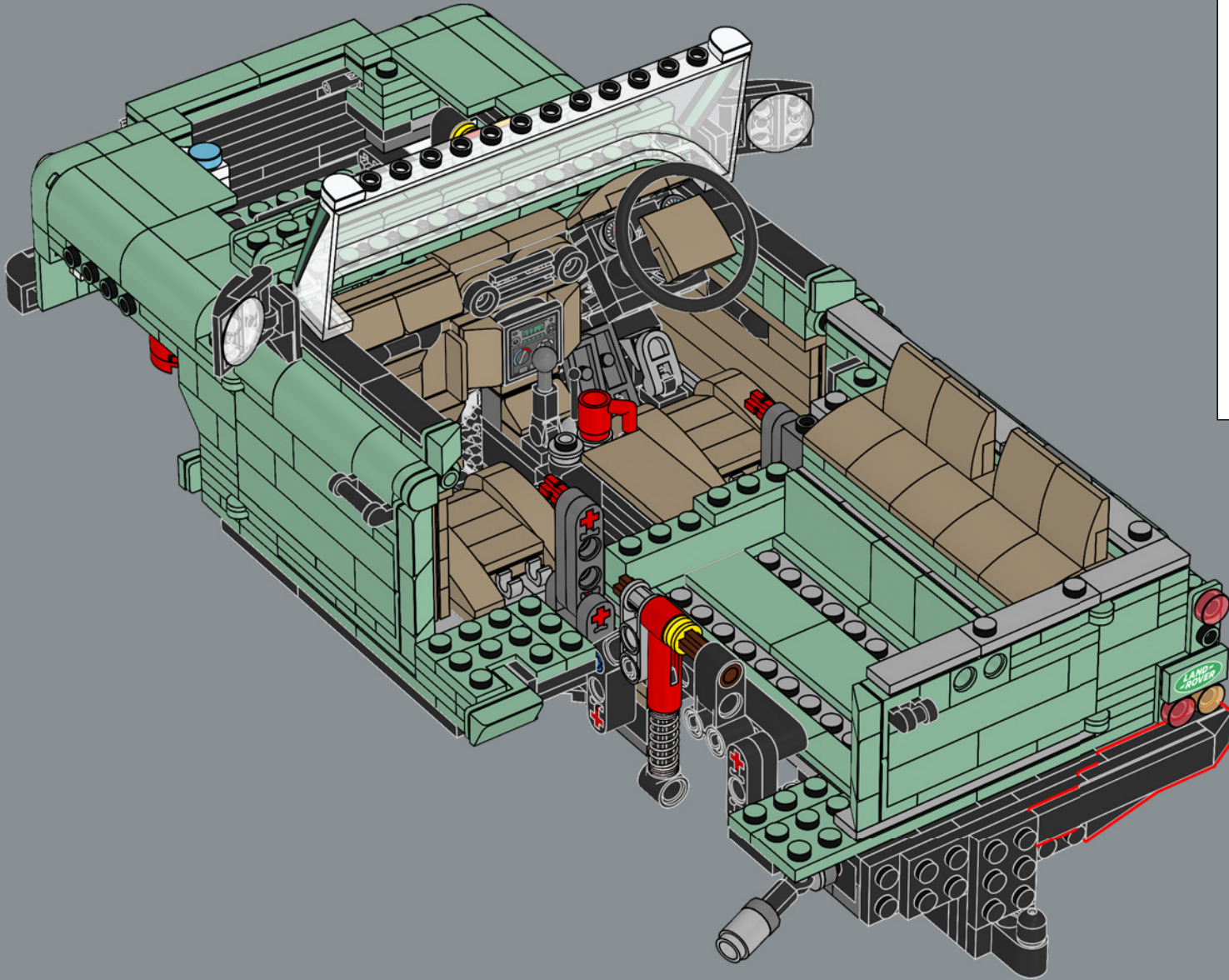

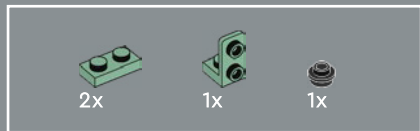

274

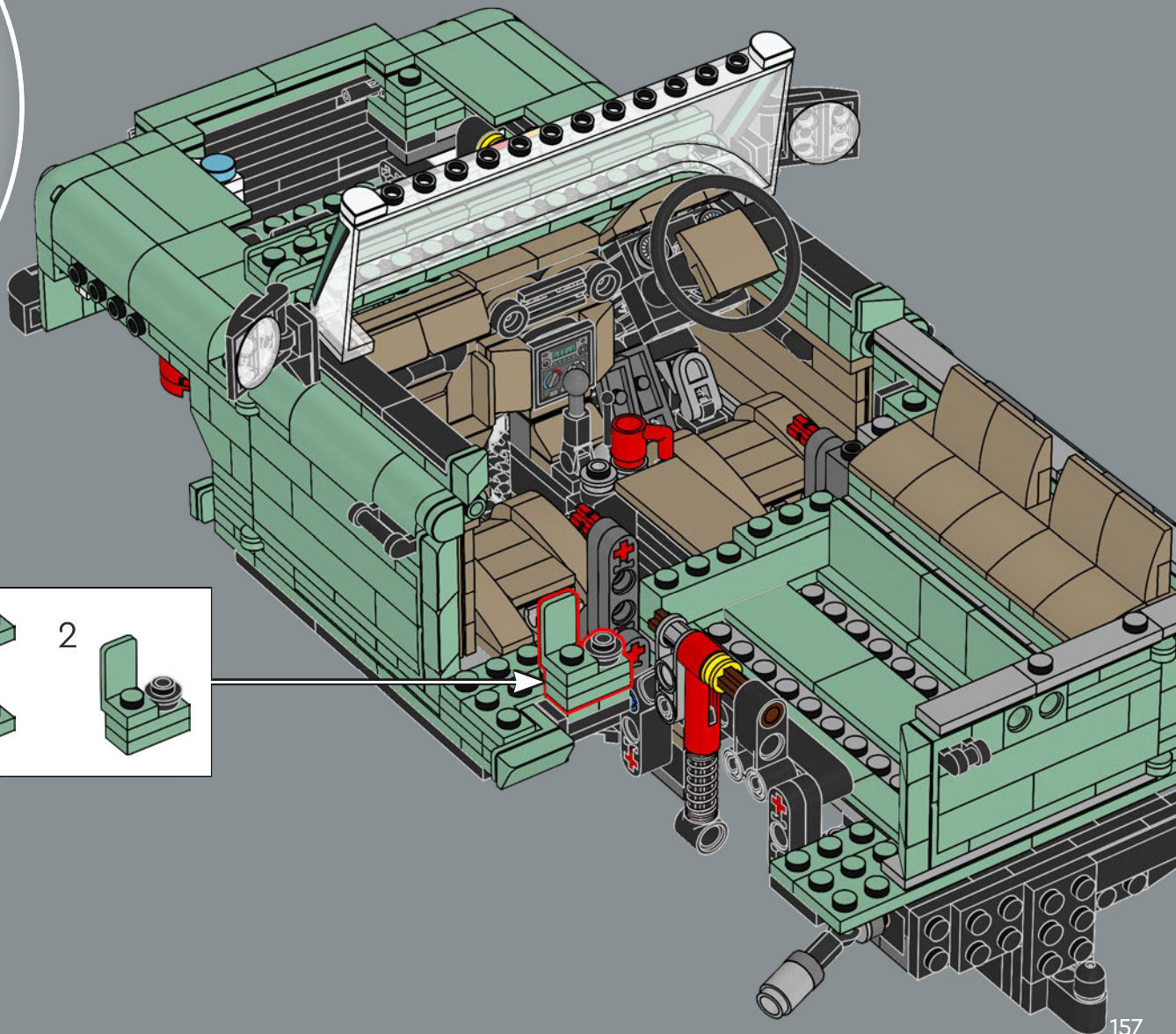
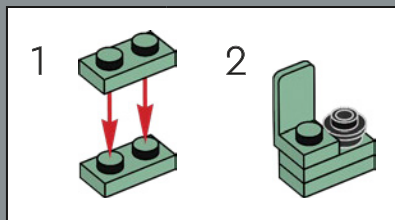

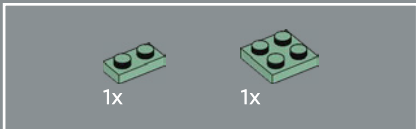
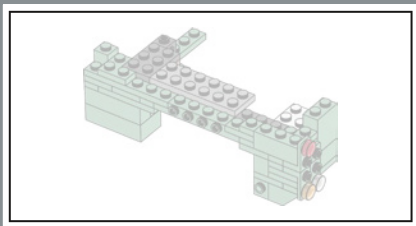

275

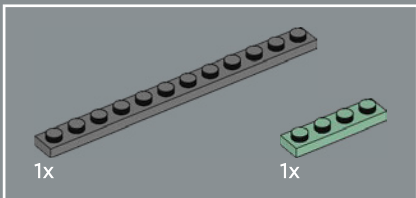
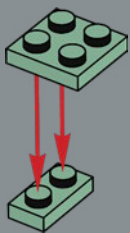

276

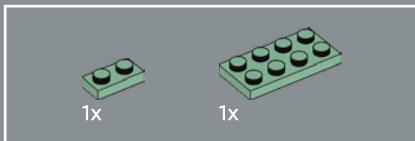
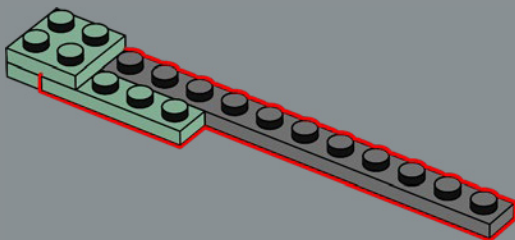

277

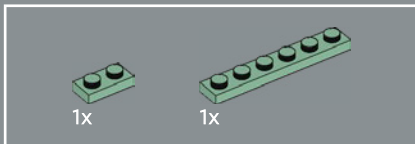
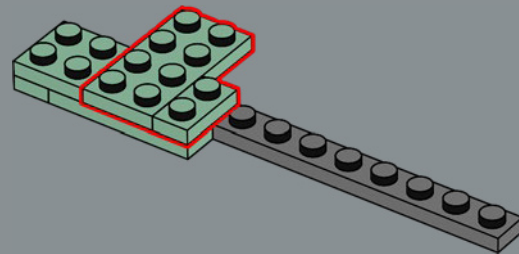

278

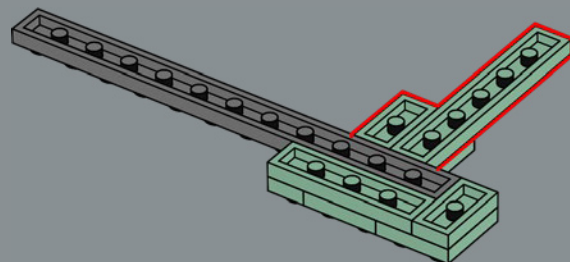

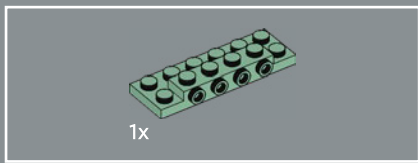

1x

279

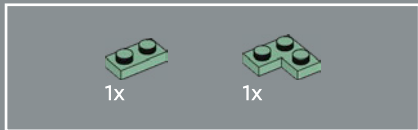
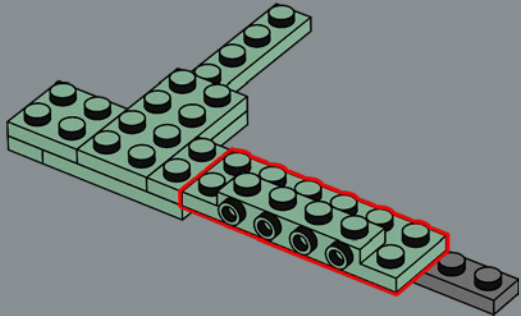

1x

1x

280

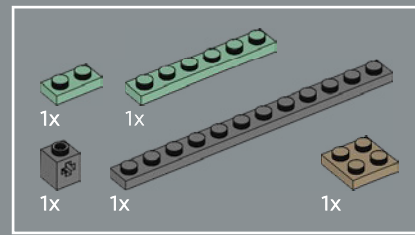
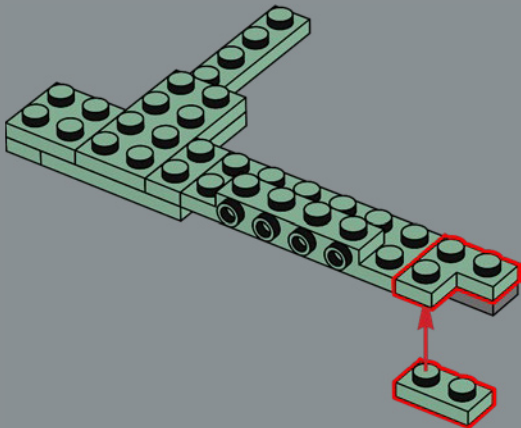

1x

1x

1x

1x

1x

281

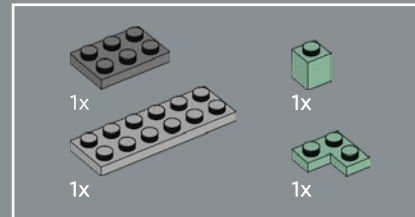
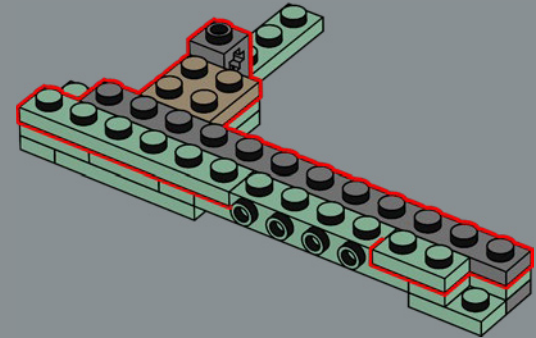

1x

1x

1x

1x

282

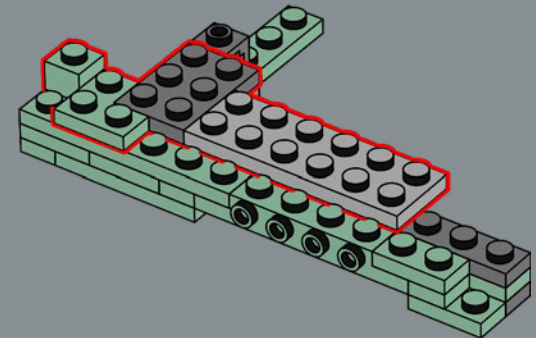

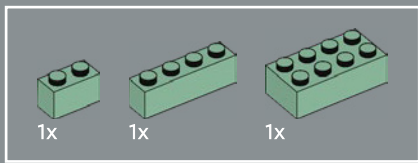

283

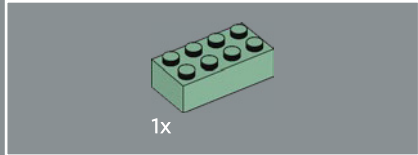
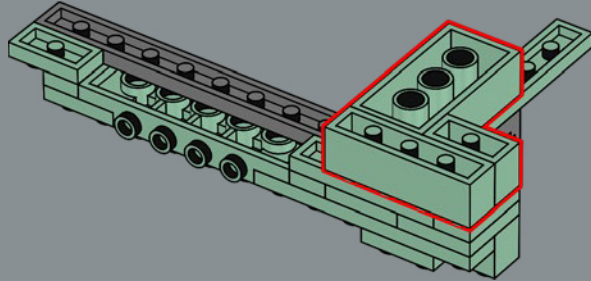

284

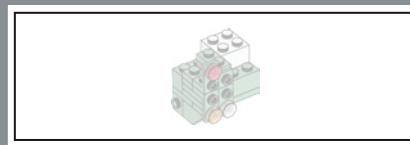
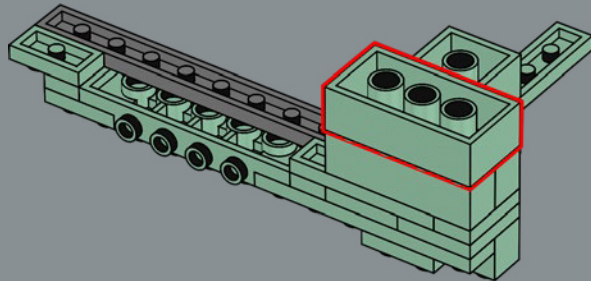

285

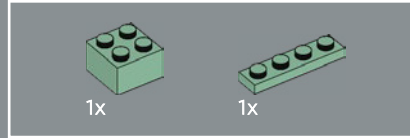
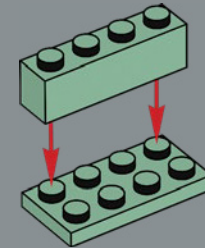
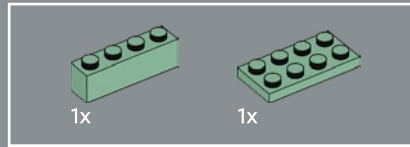

286

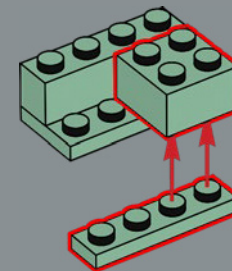

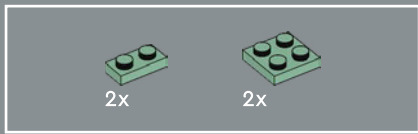

287

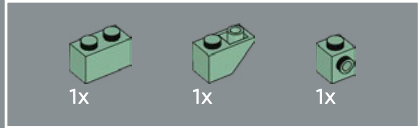
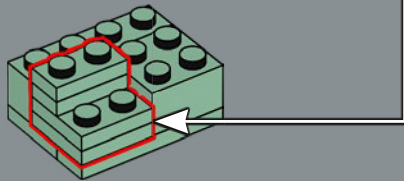
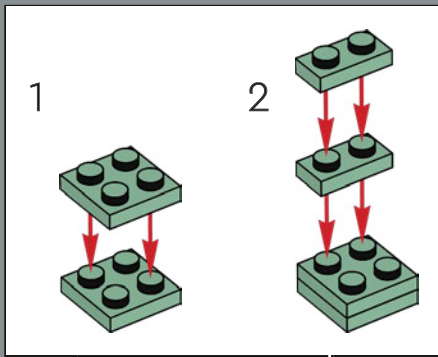

288

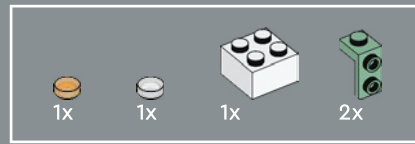
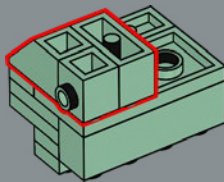

289

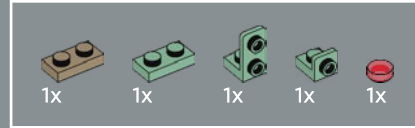
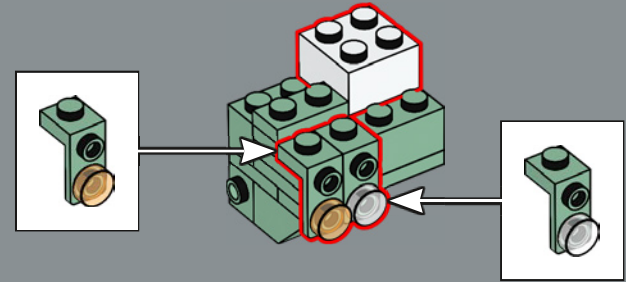

290

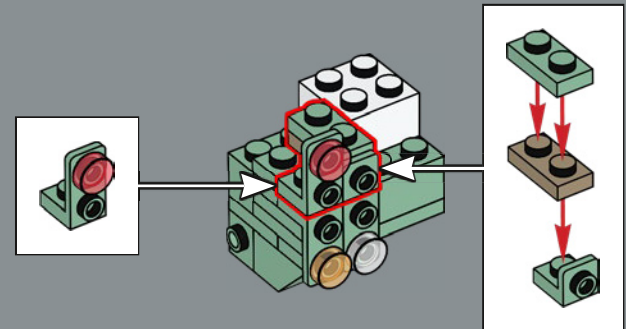

291

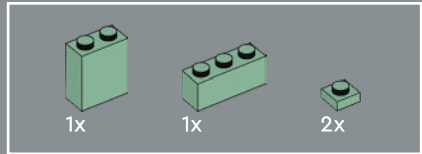
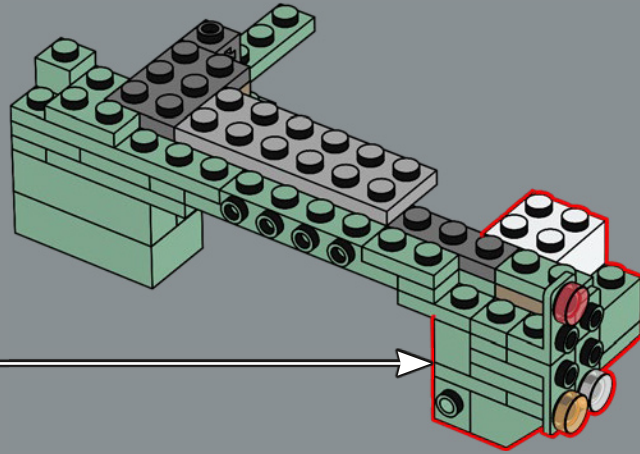

292

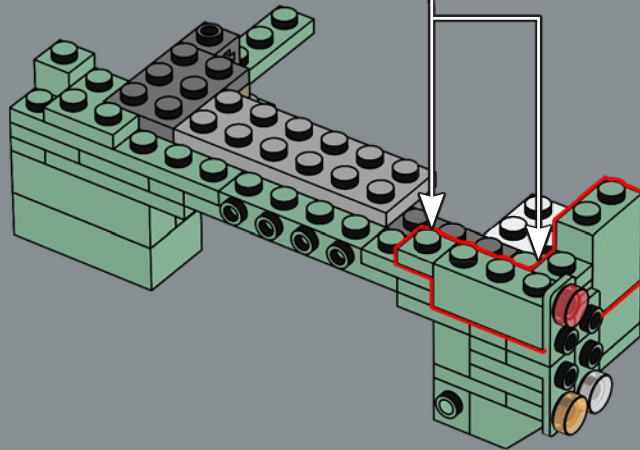
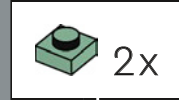

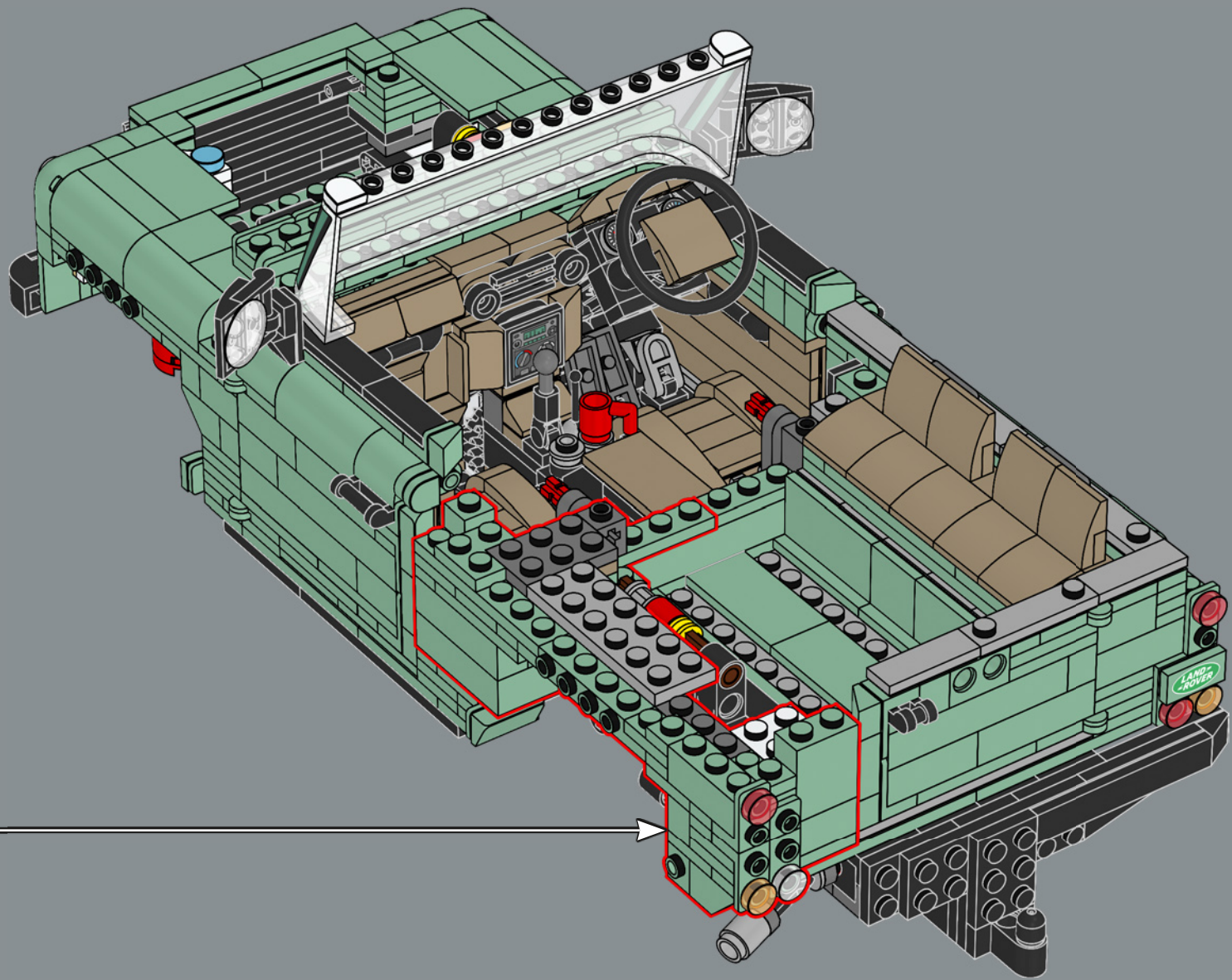

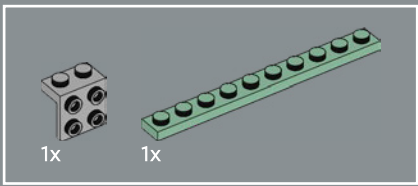

294

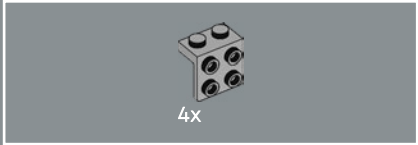
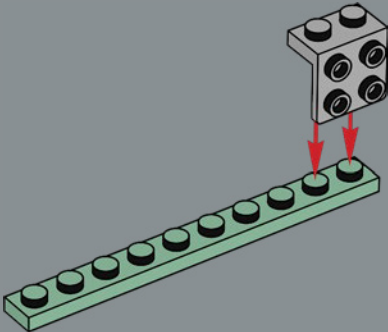

295

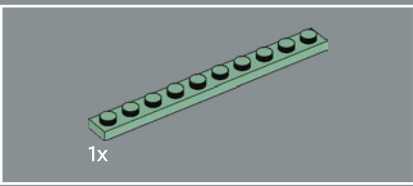
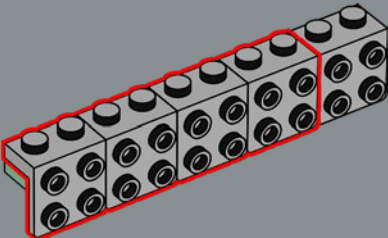

296

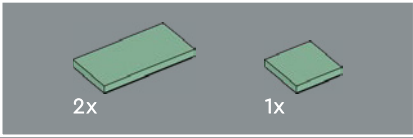
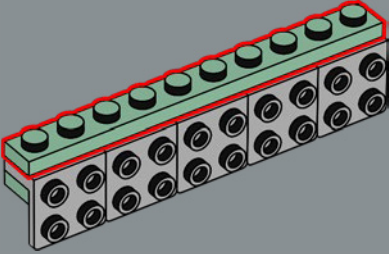

297

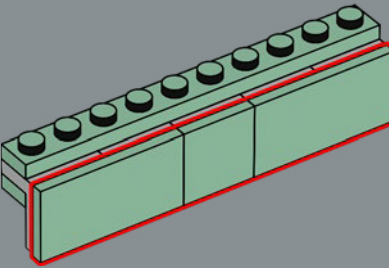

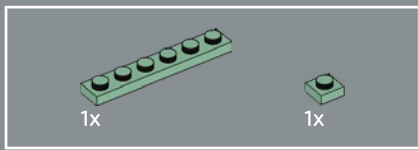

298

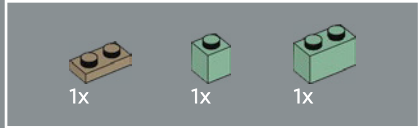
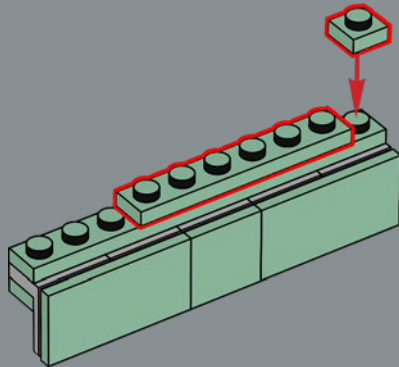

299

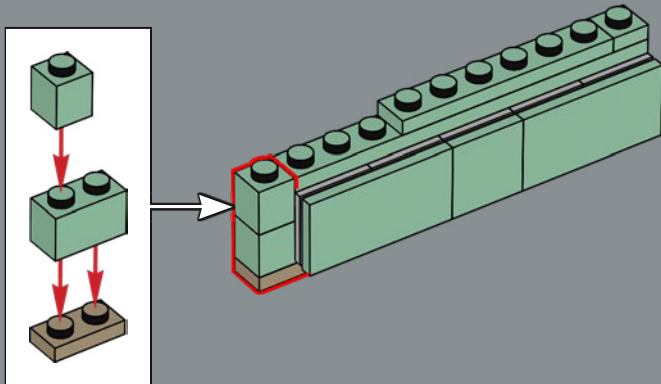

300

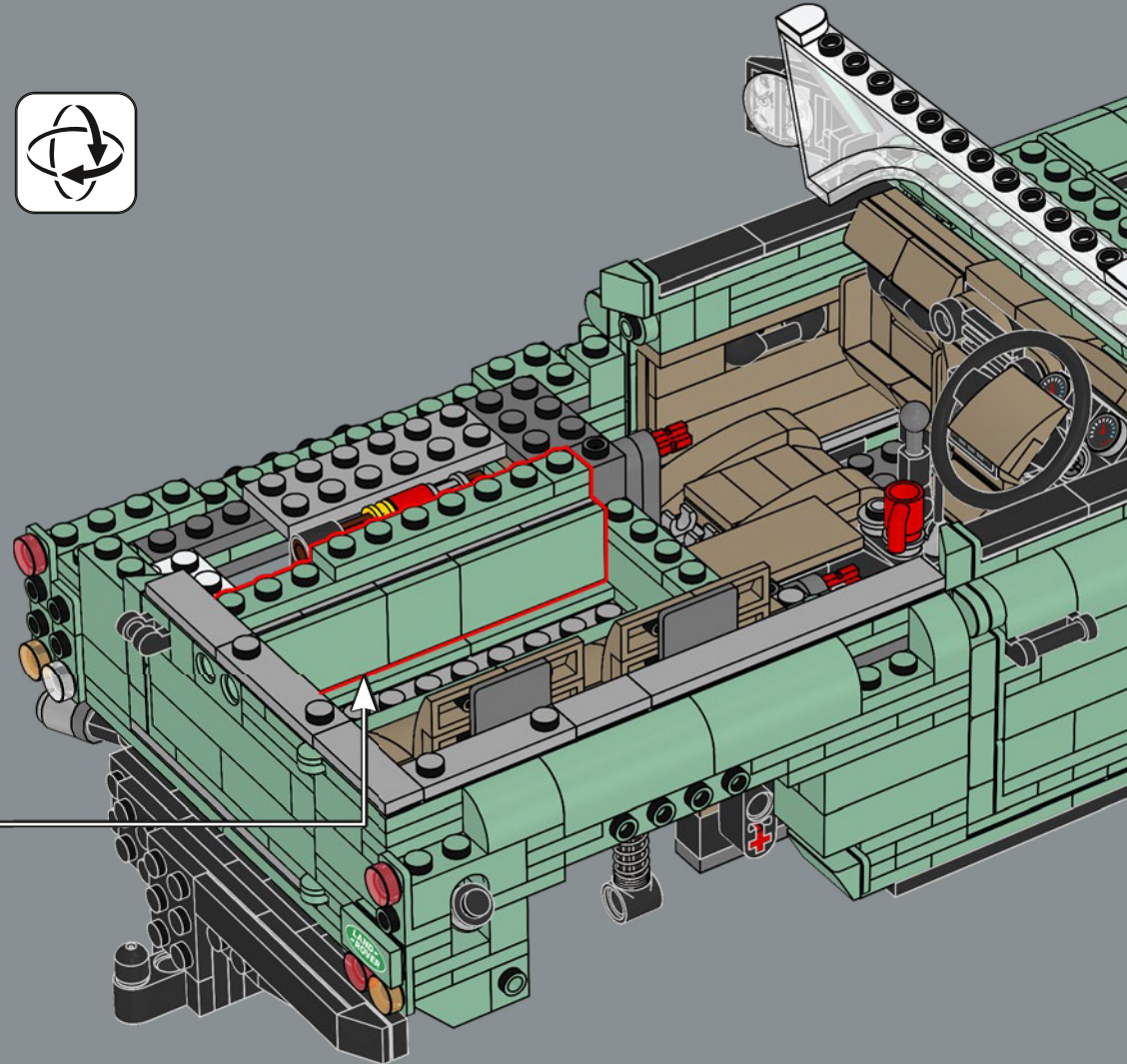

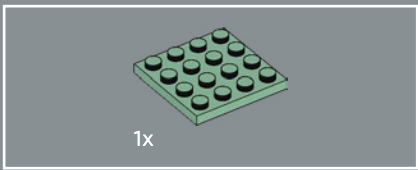

301

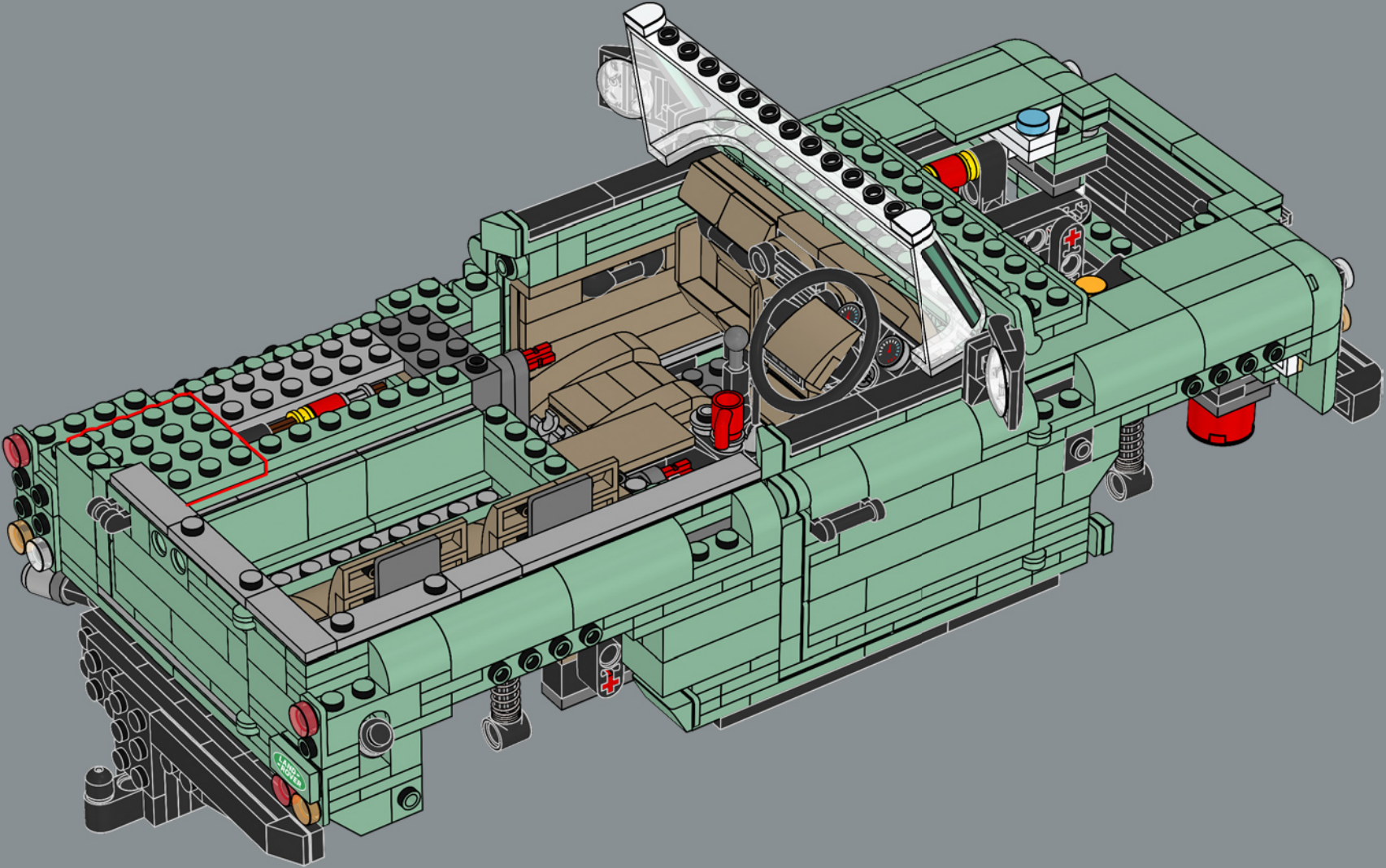

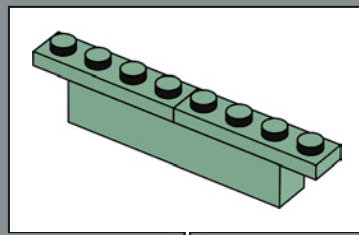
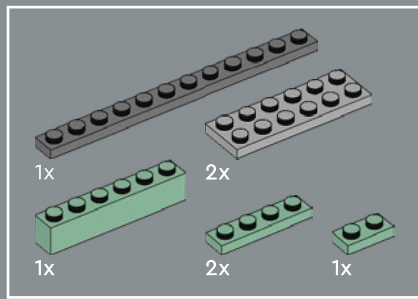

302

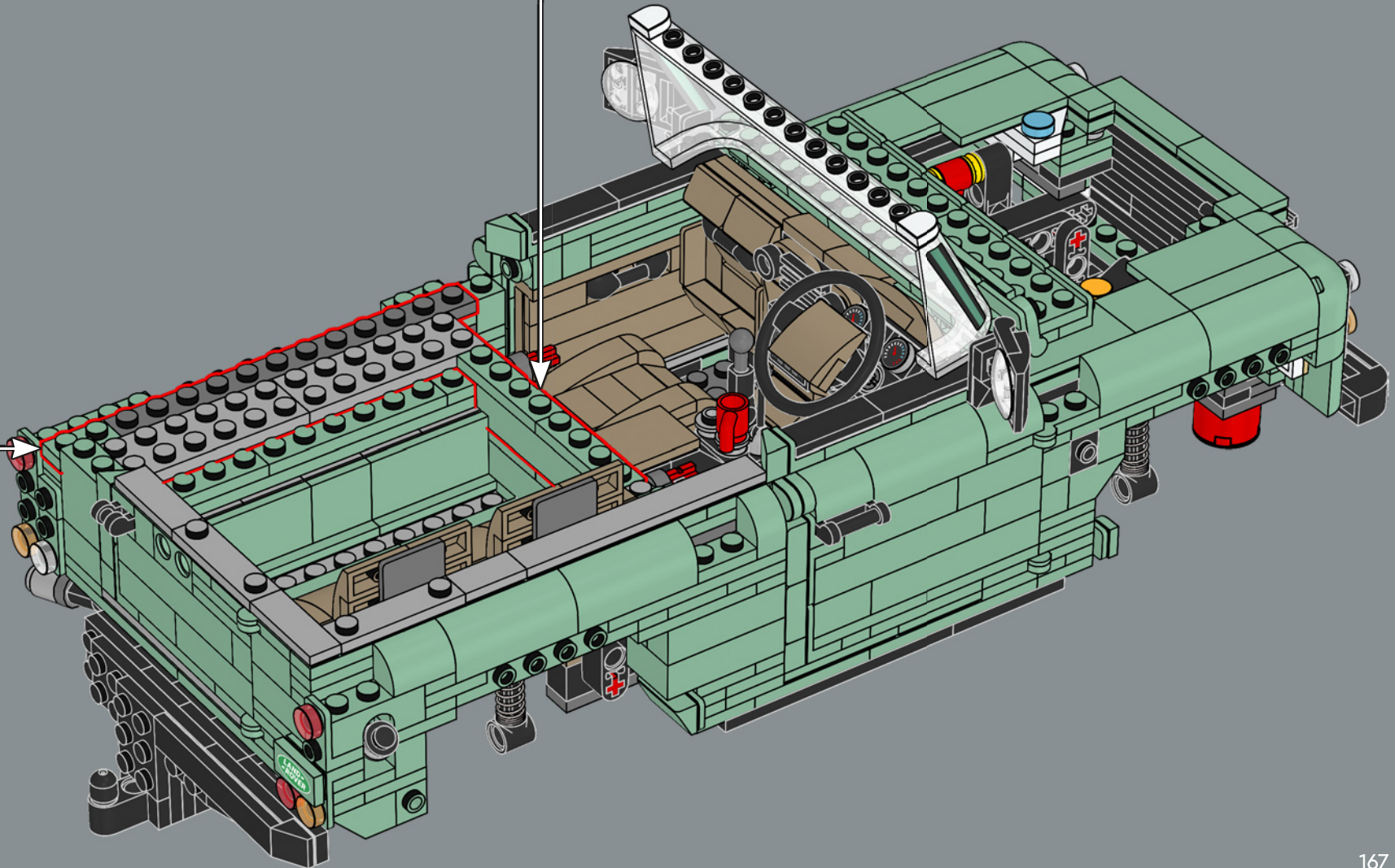
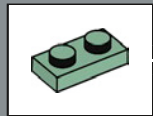

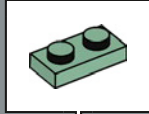
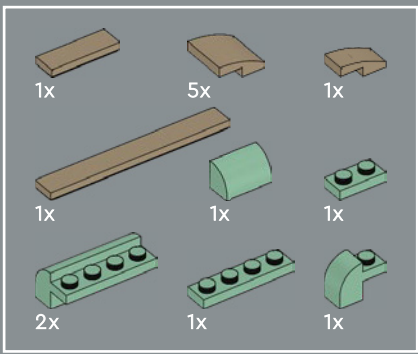

303

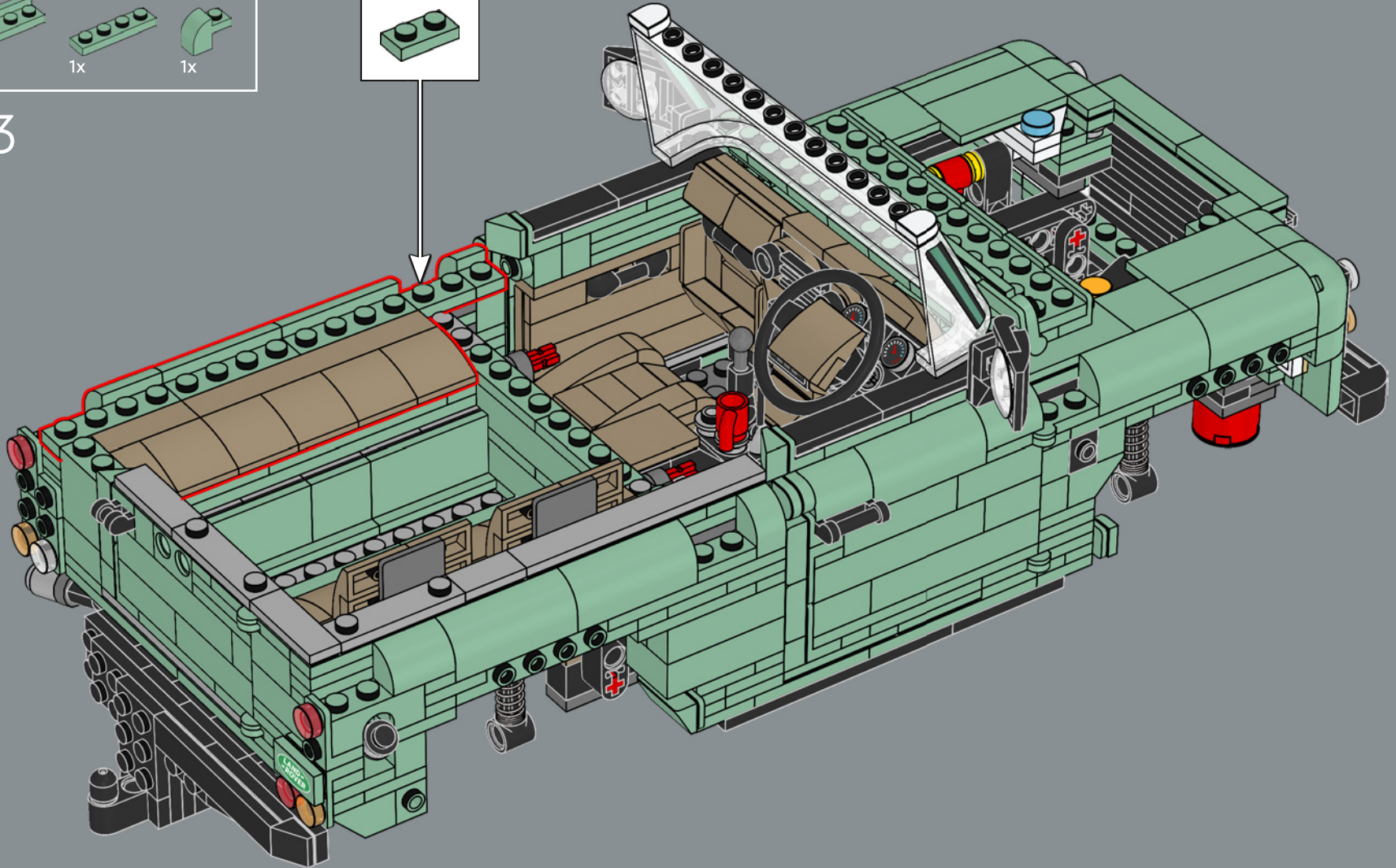

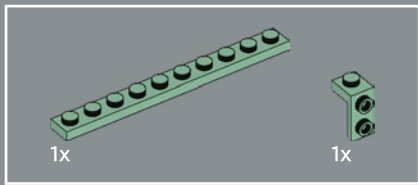

304

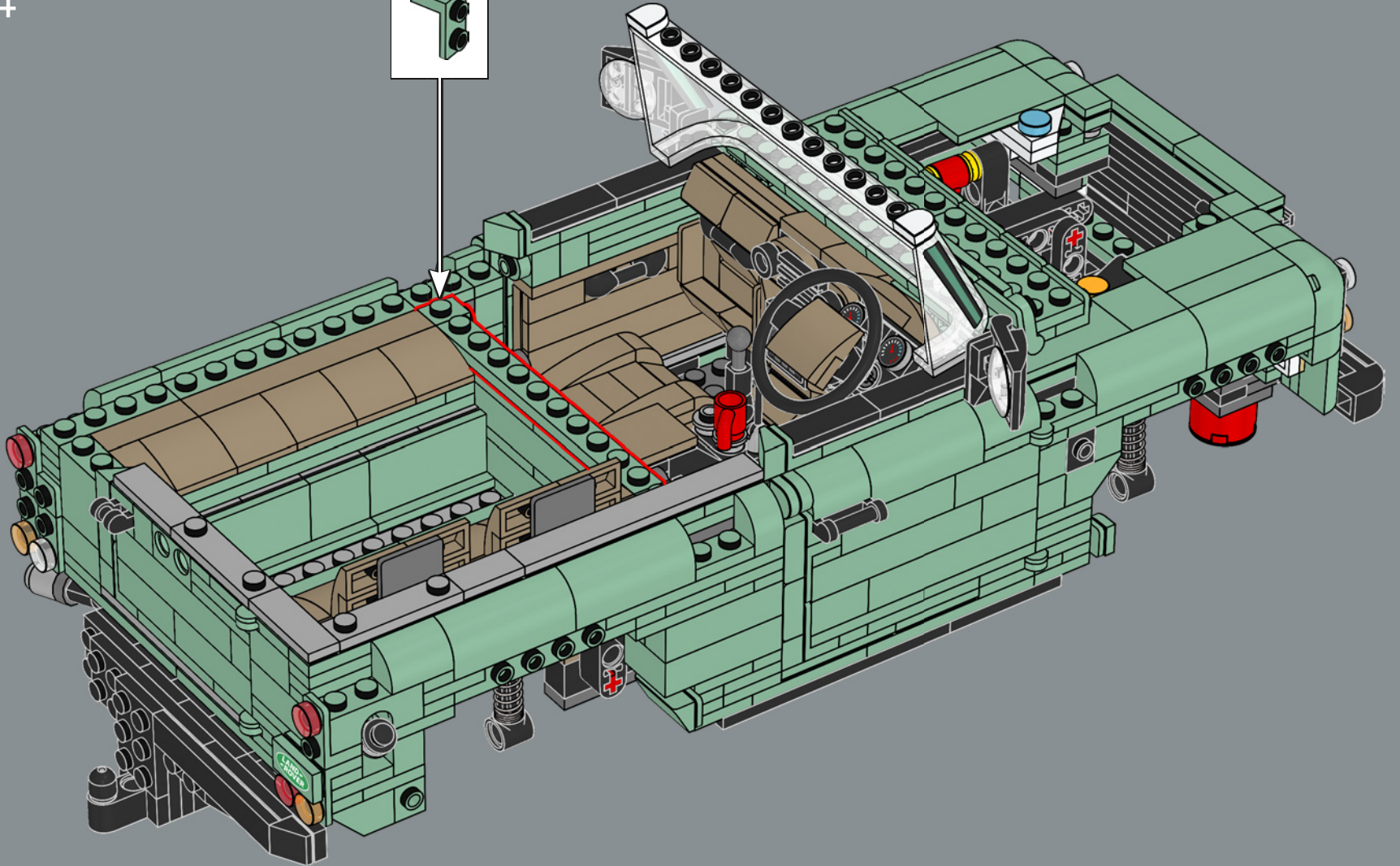
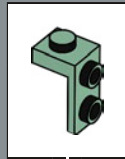

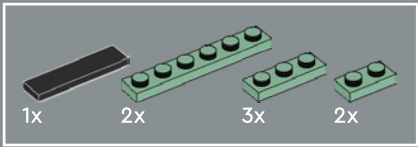

305

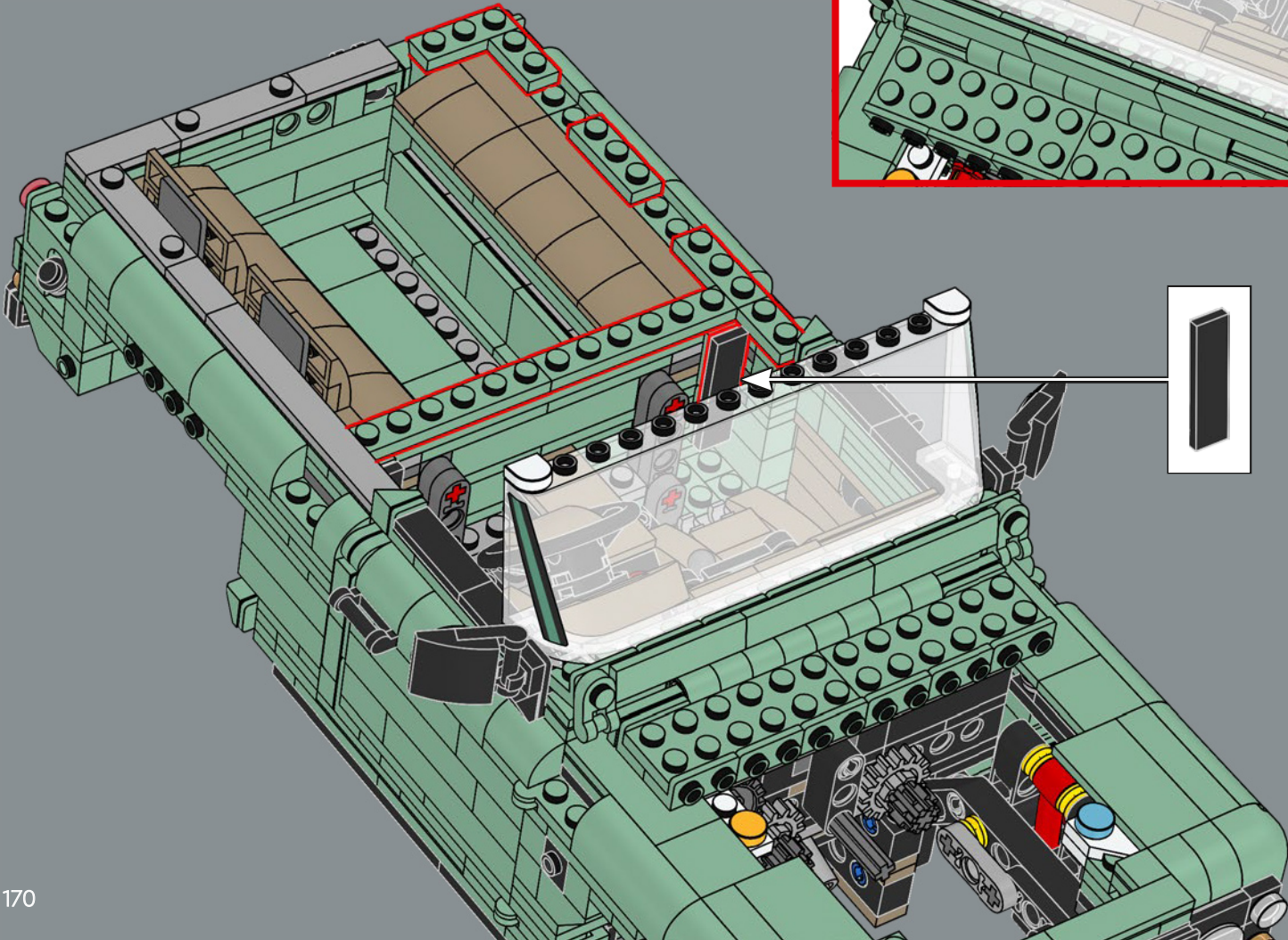
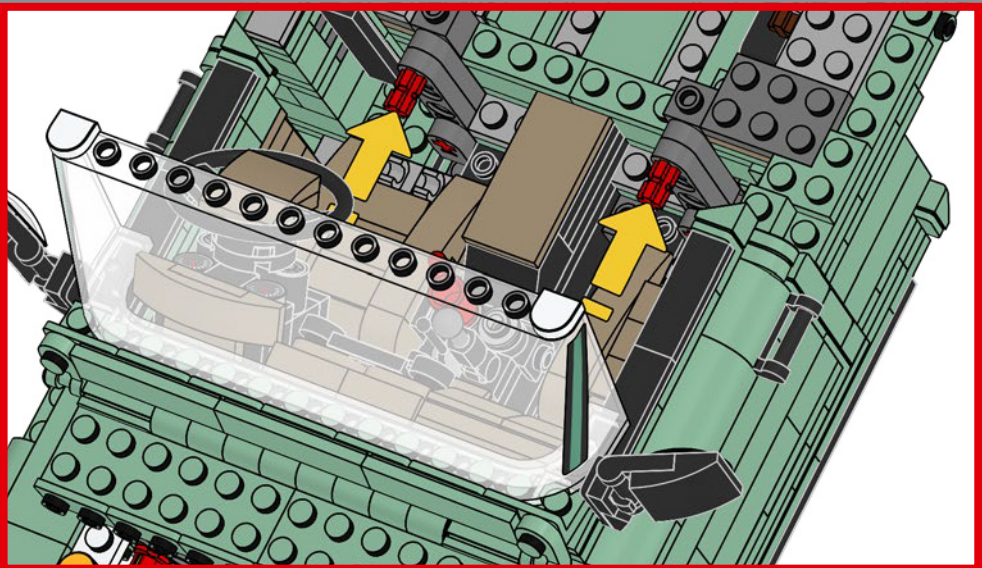

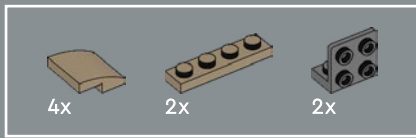

306

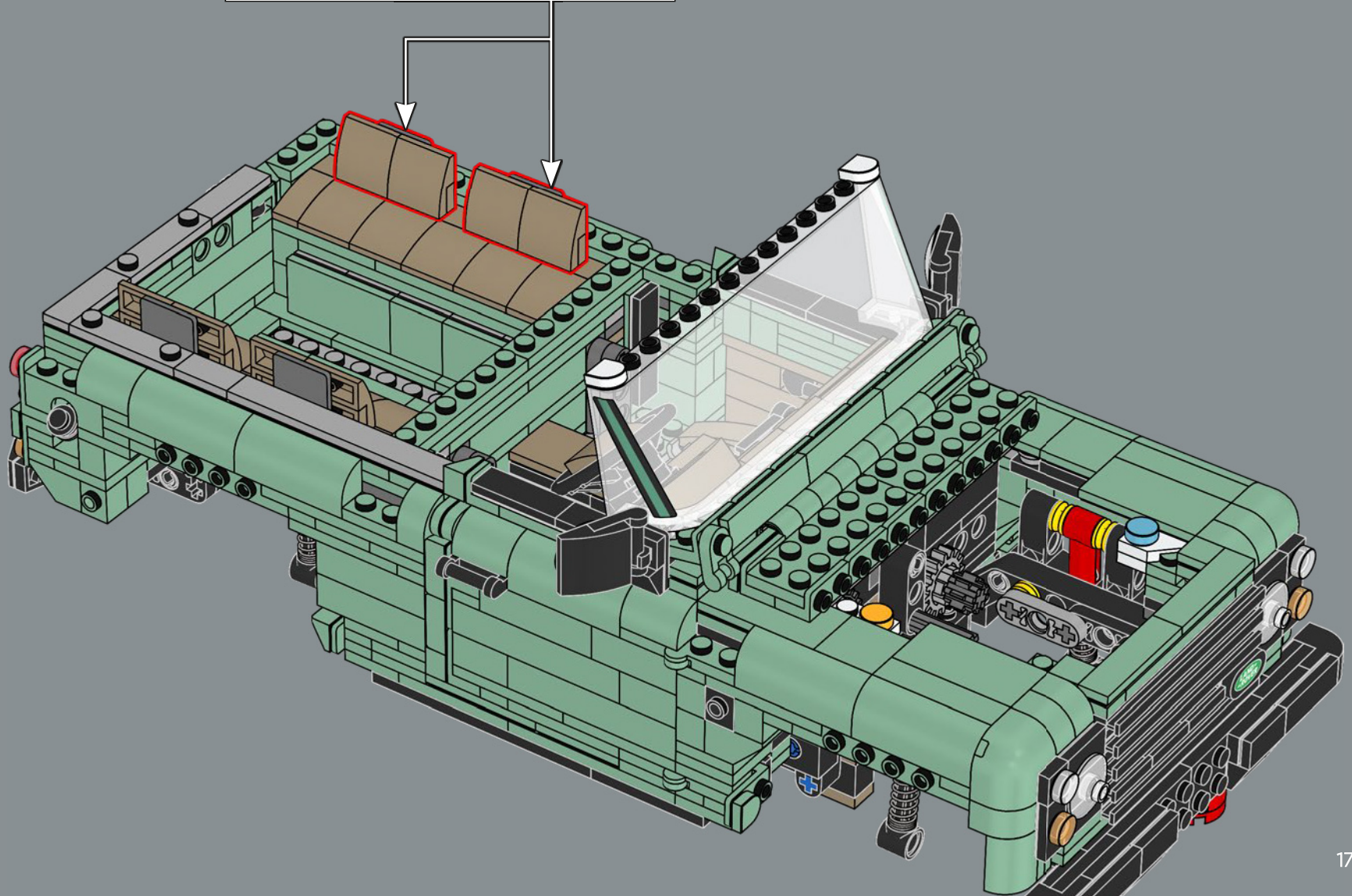
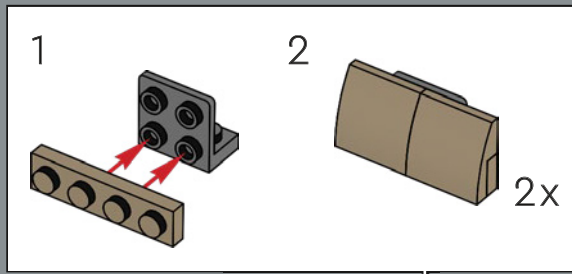

The official LEGO® color code of the seats is 138, but LEGO designers call it 'wet sand.'

Les sièges portent la couleur LEGO® 138, que les concepteurs LEGO appellent « sable mouillé ».

El código oficial de LEGO® para el color de los asientos es 138, pero los diseñadores de LEGO lo llaman "arena mojada".

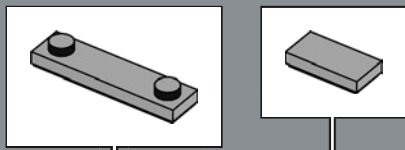
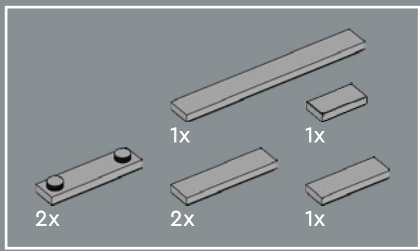

307

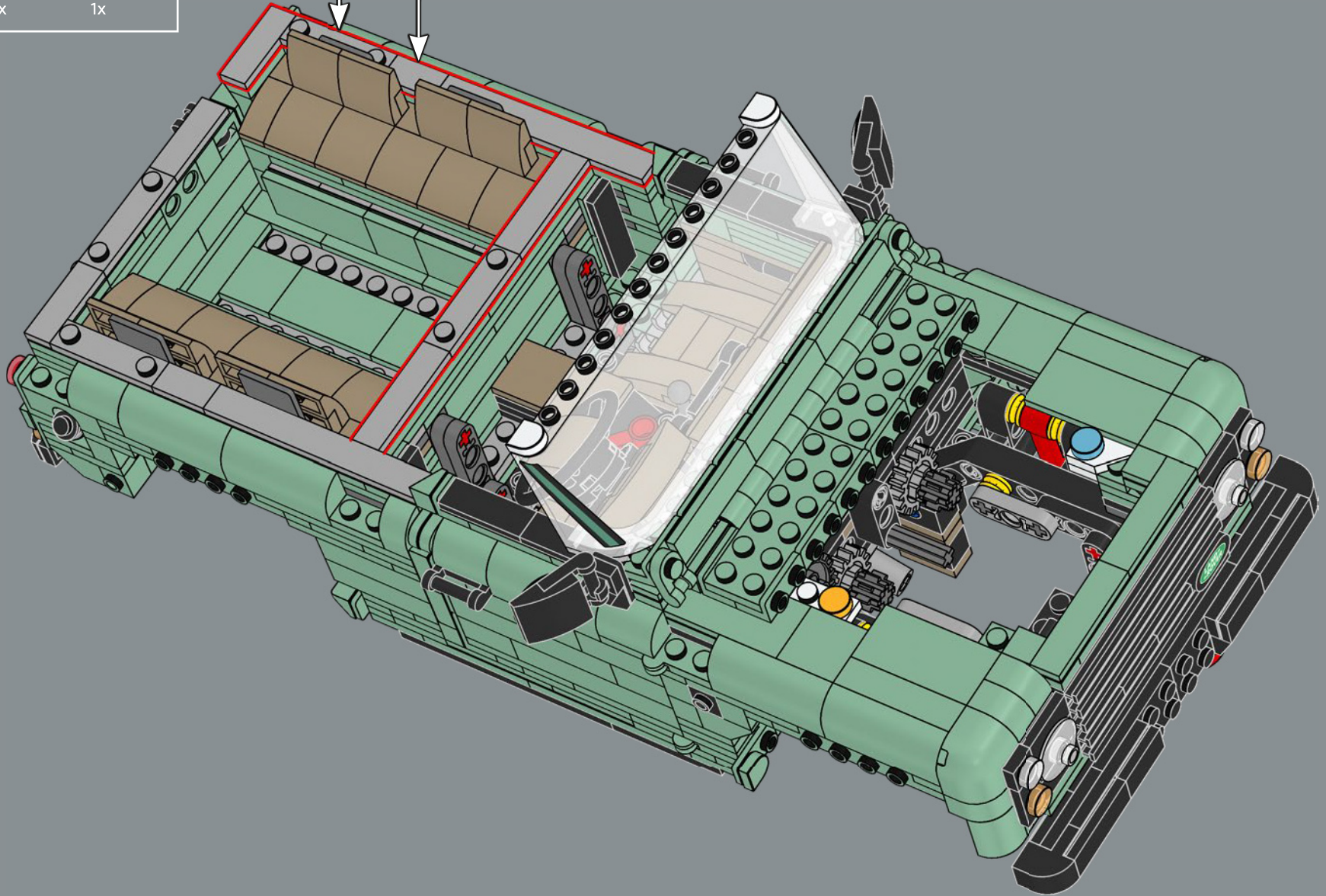

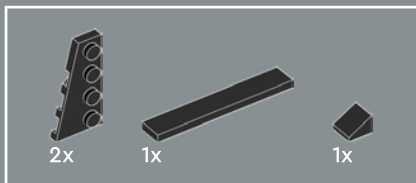

308

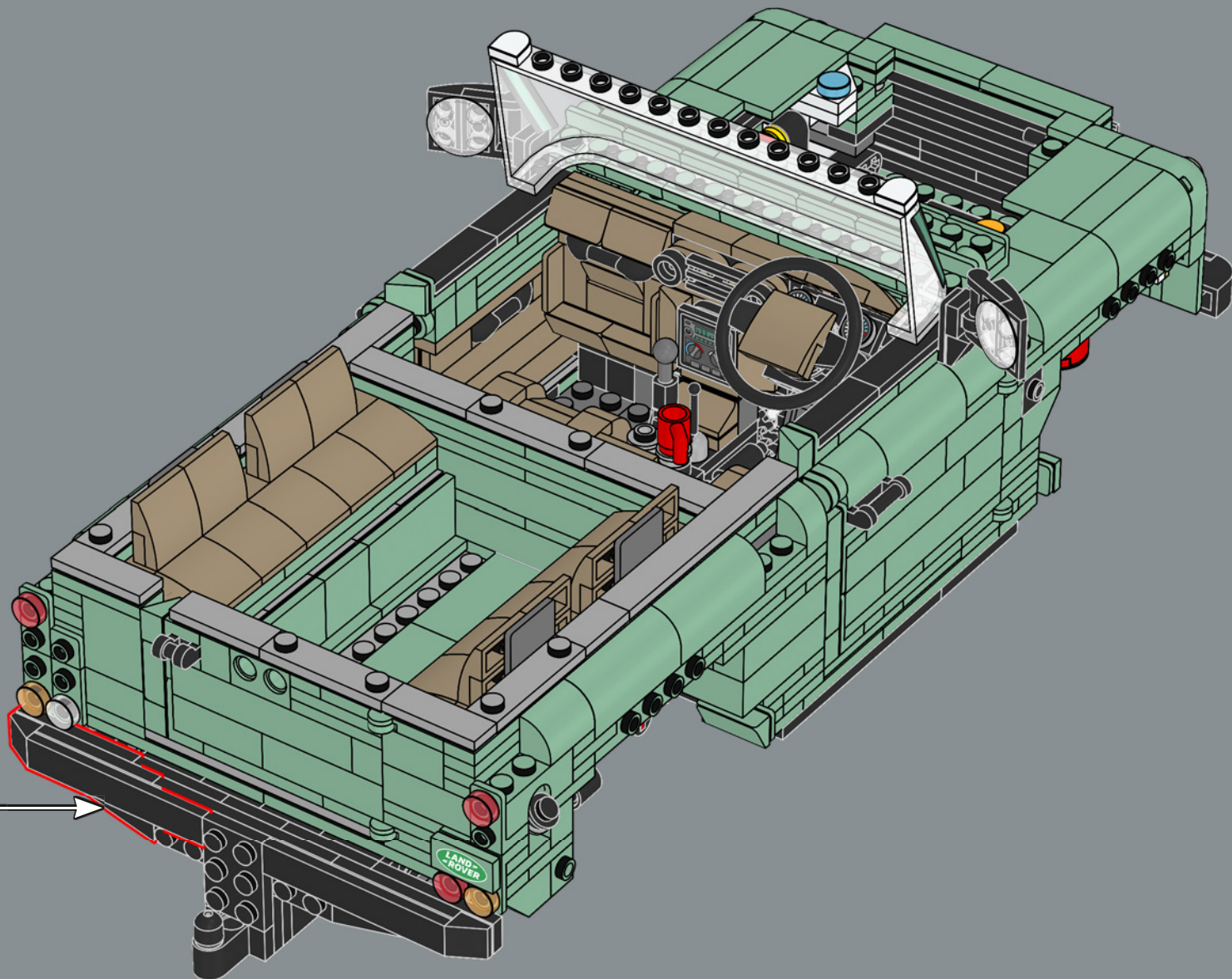
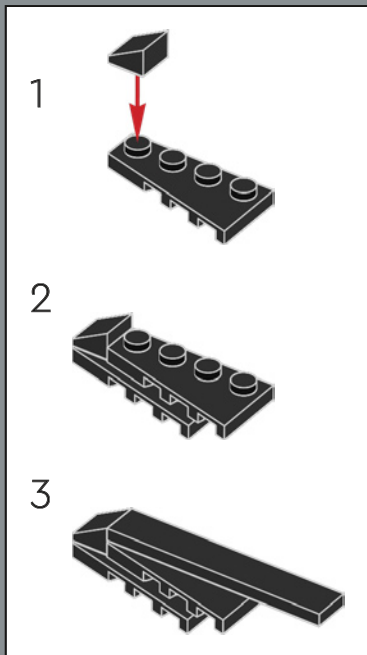

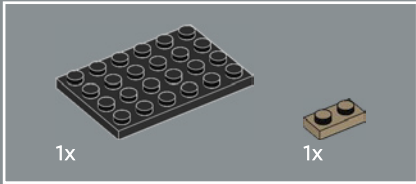
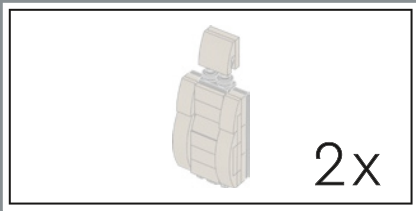

309

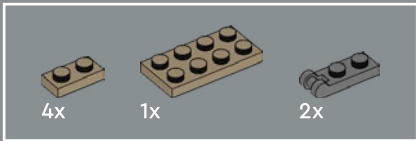
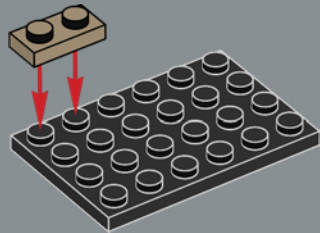

310

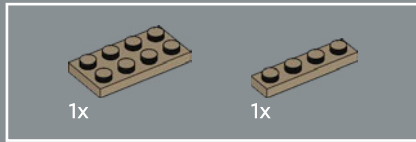
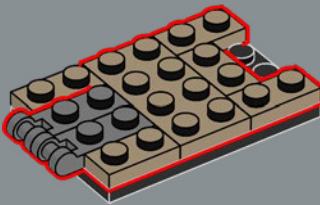

311

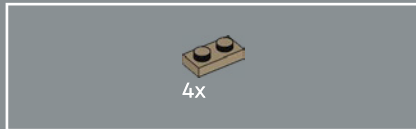
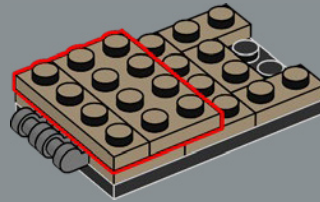

312

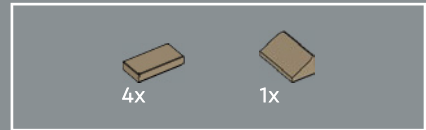
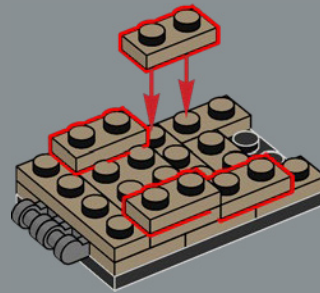

313

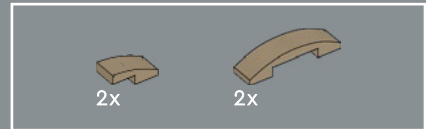
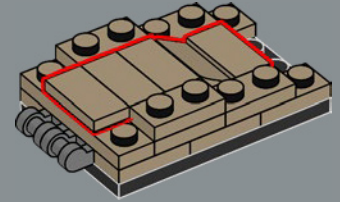

314

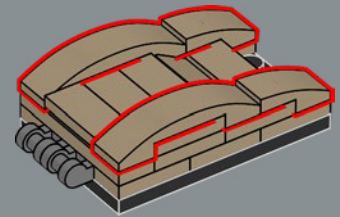

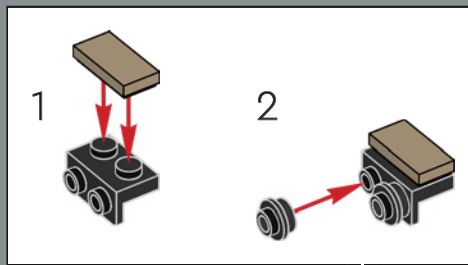
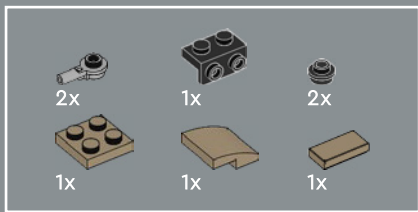

315

1

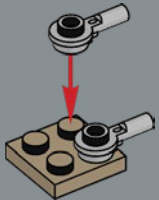

2

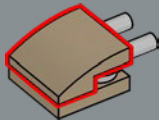

3

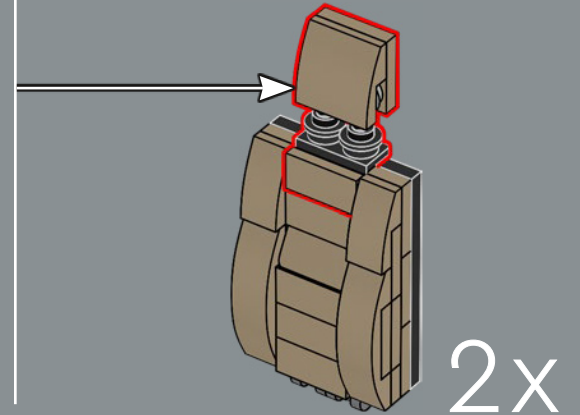
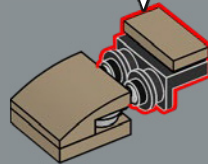

316

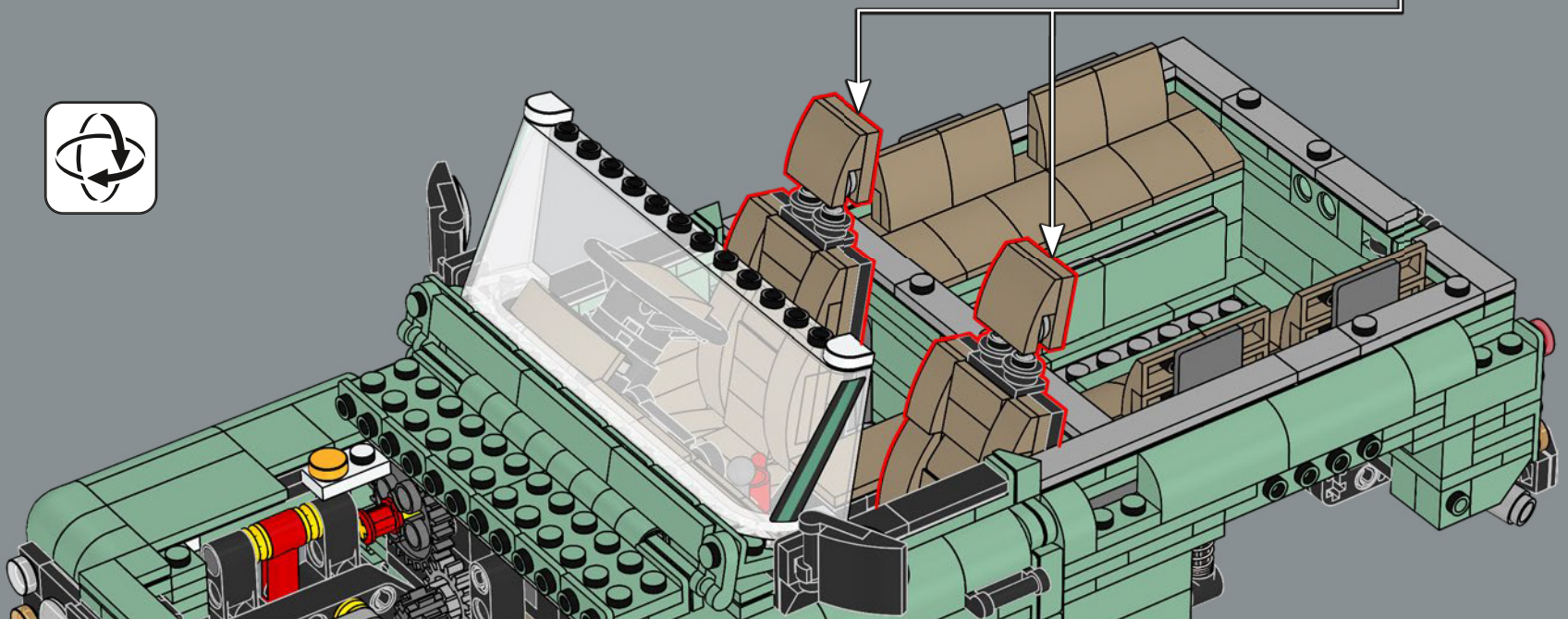

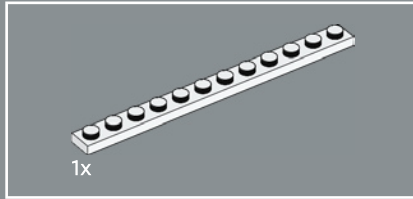
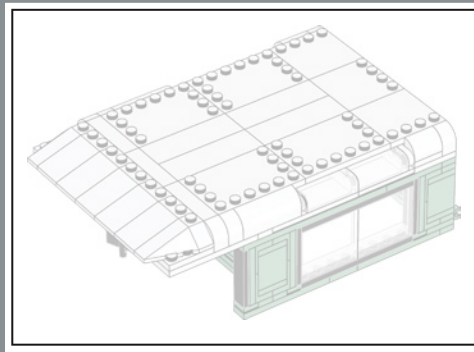

317

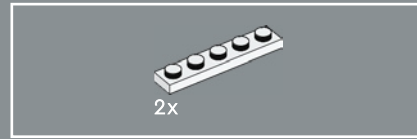
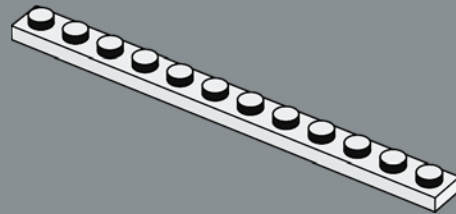

318

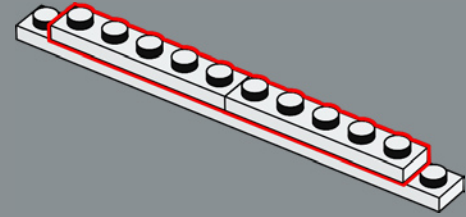

319

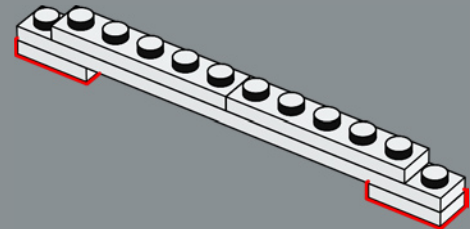

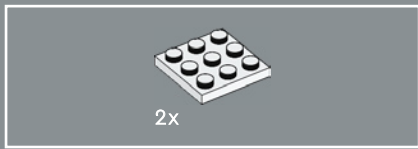

320

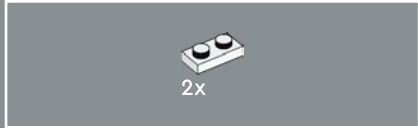
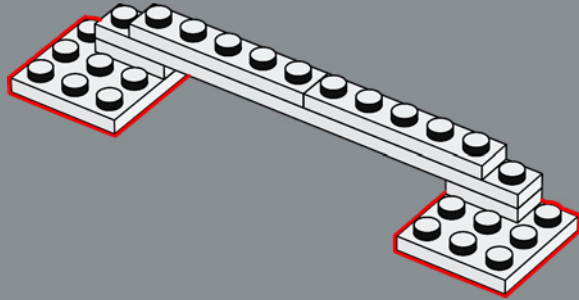

321

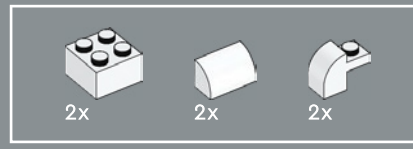
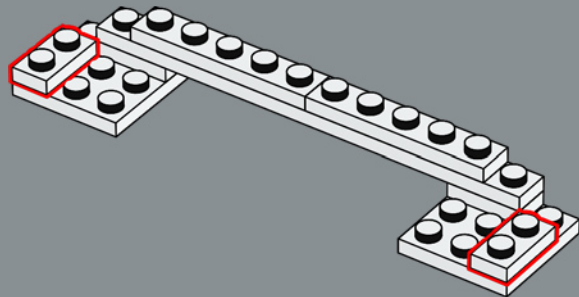

322

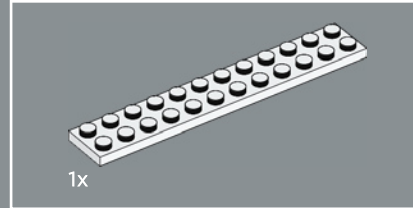
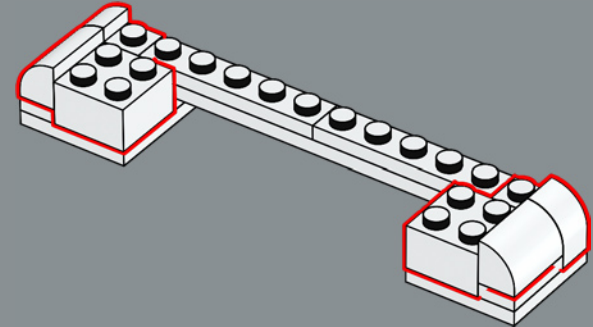

323

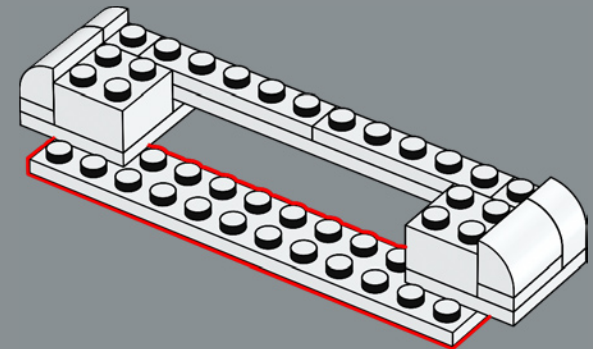

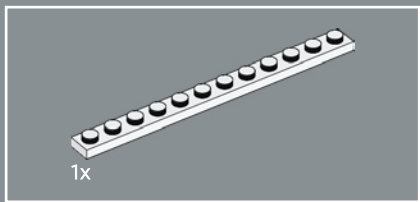

324

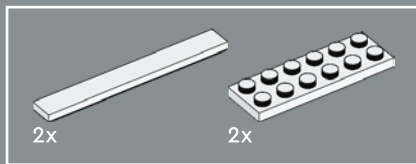
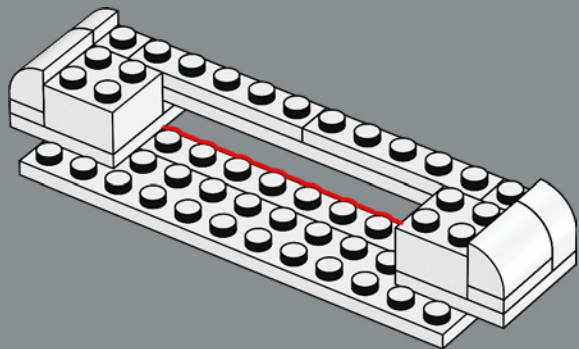

325

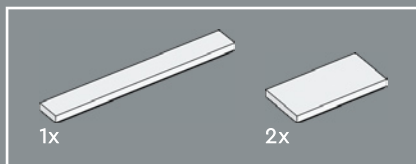
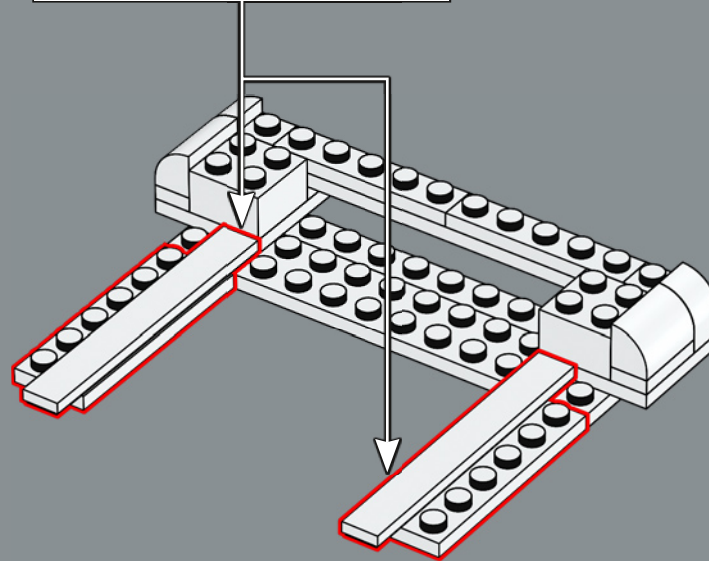
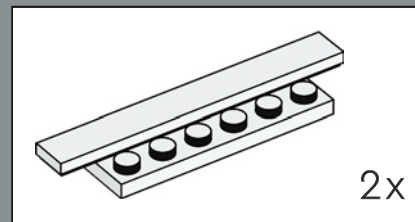

326

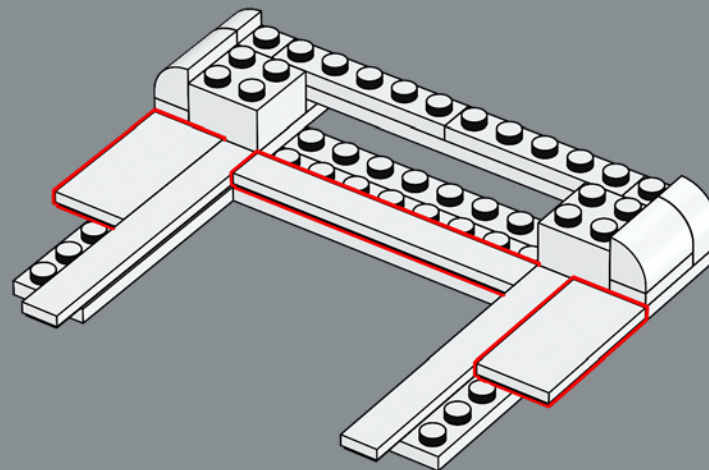

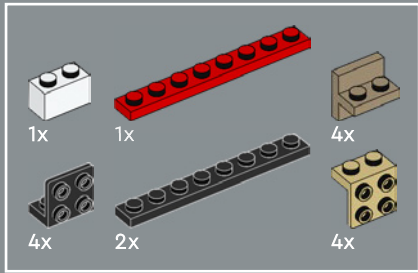

327

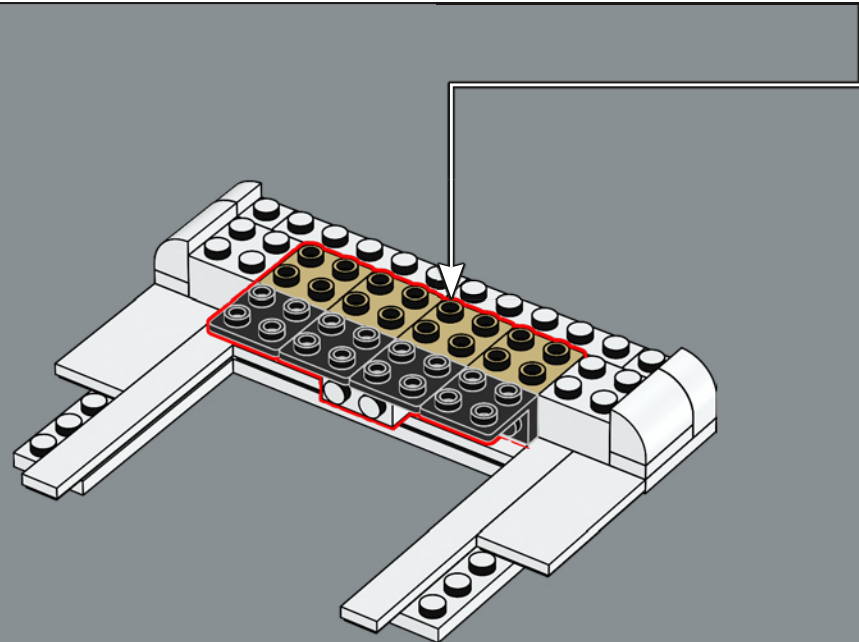
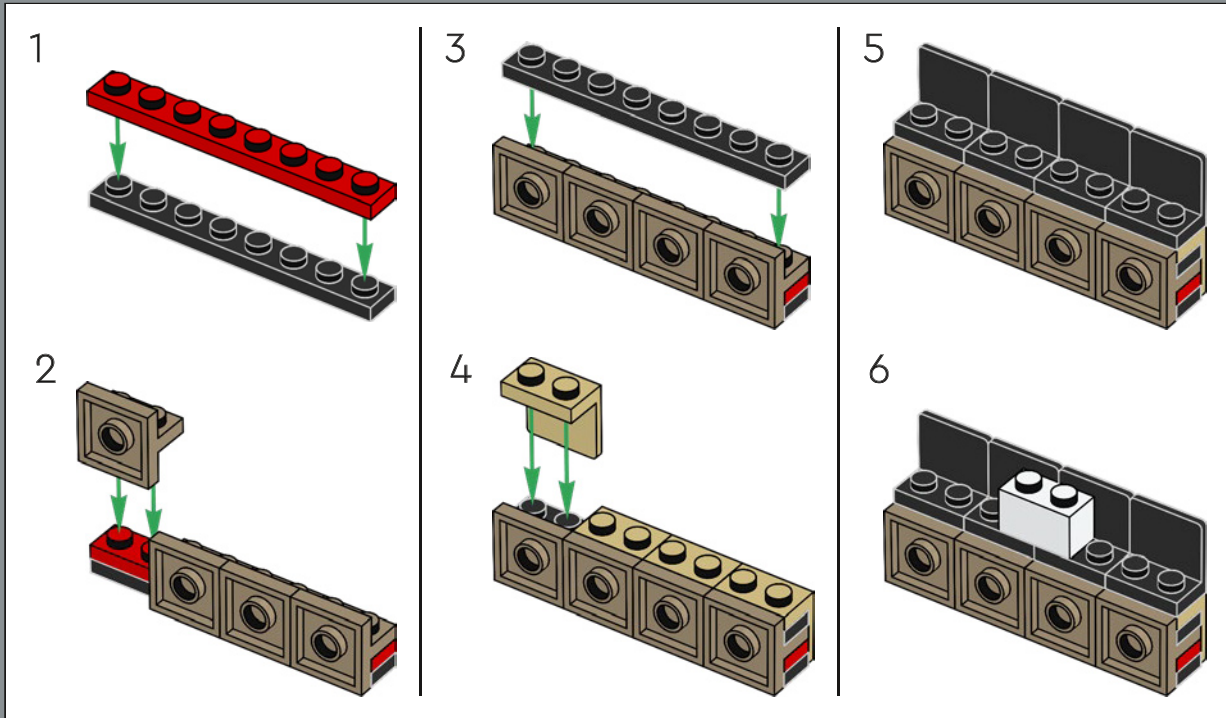

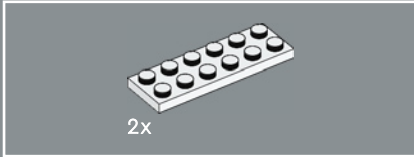
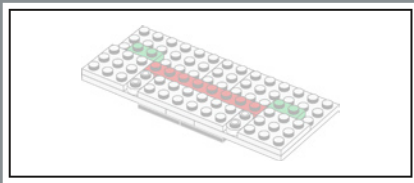

330

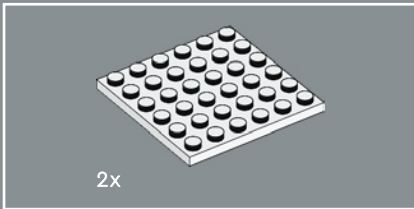
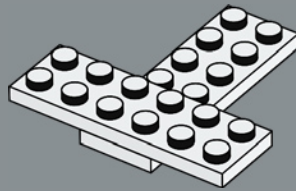

331

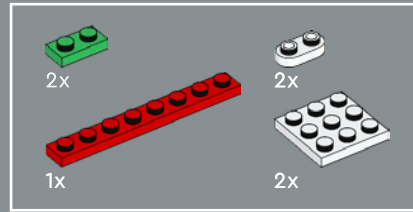
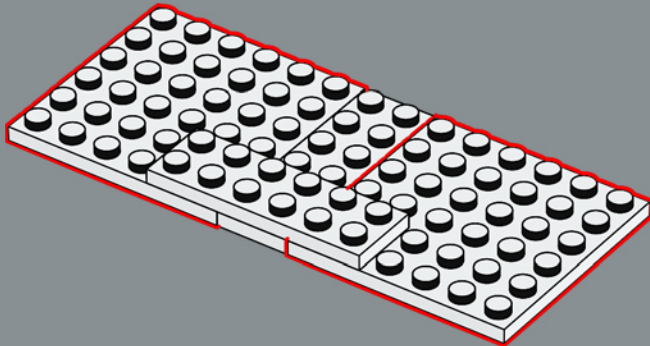

332

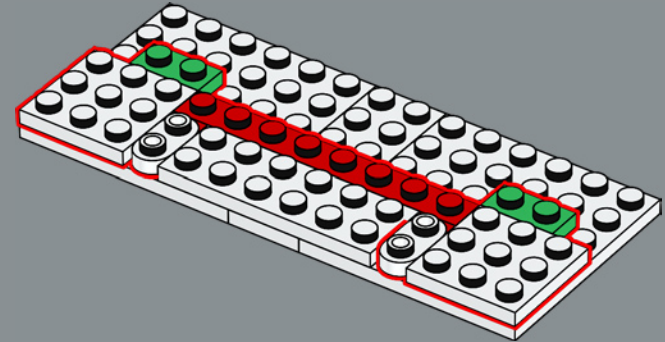

333

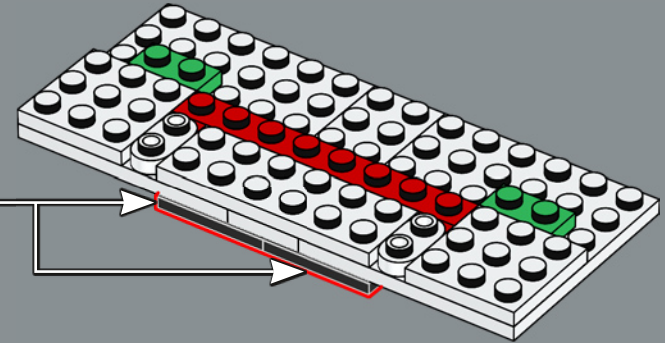

334

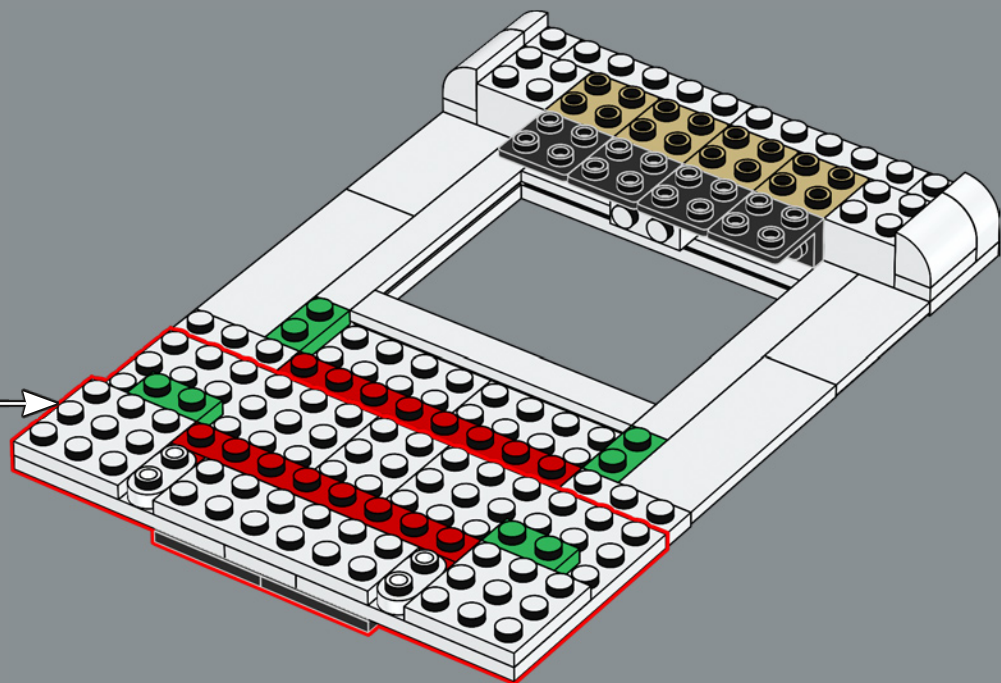

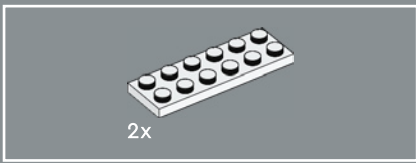

335

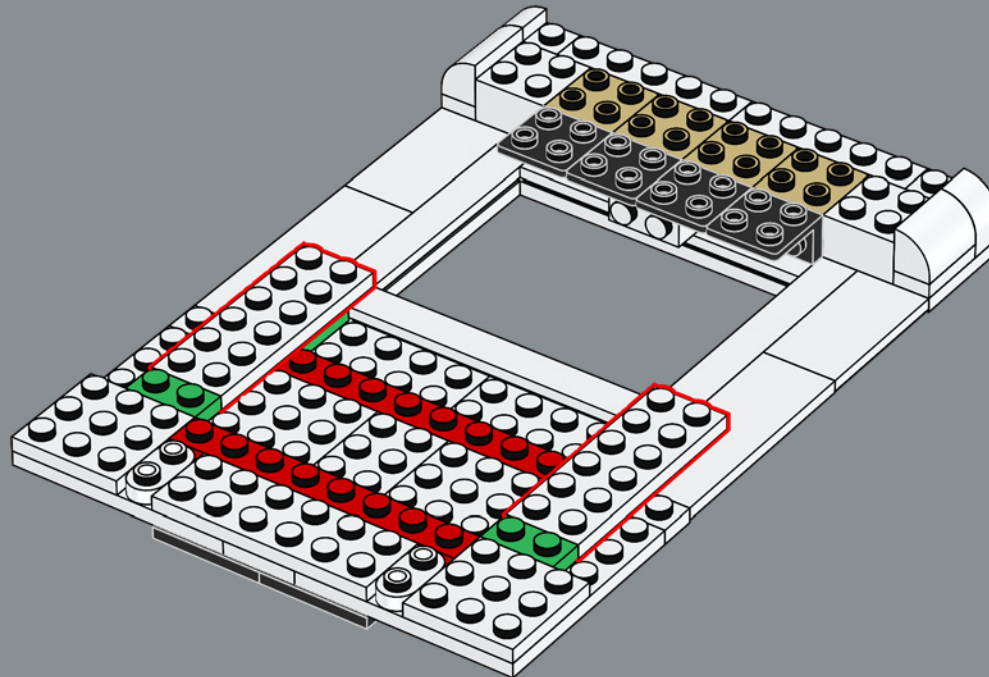

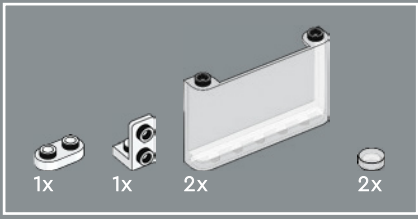

336

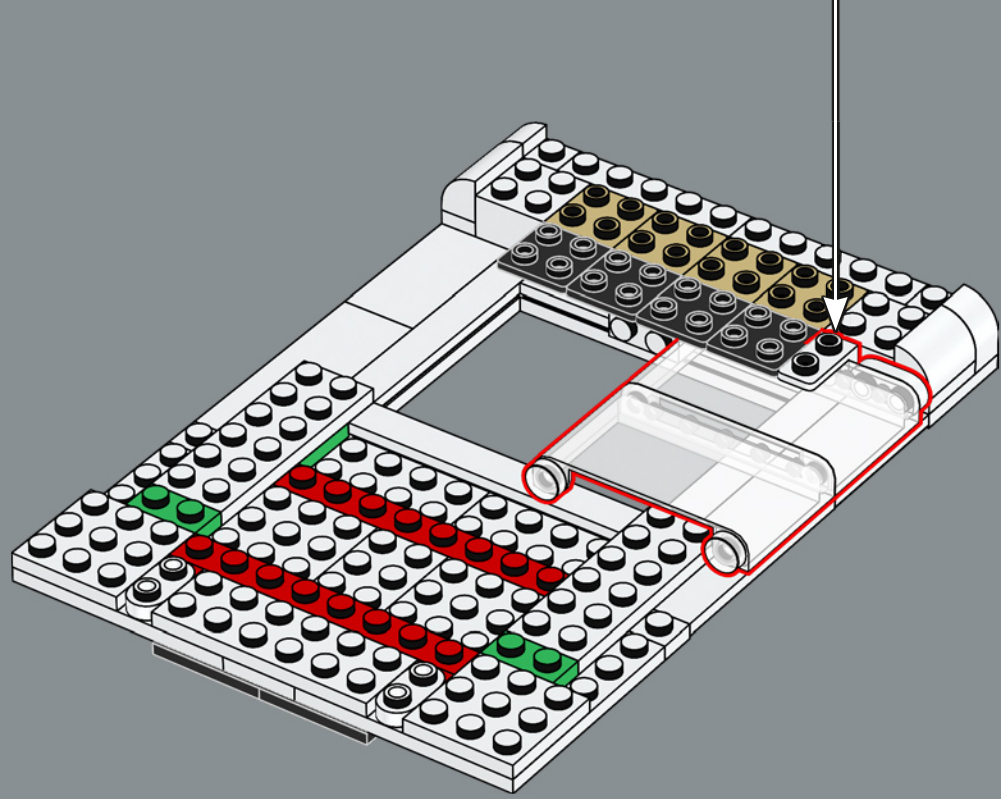
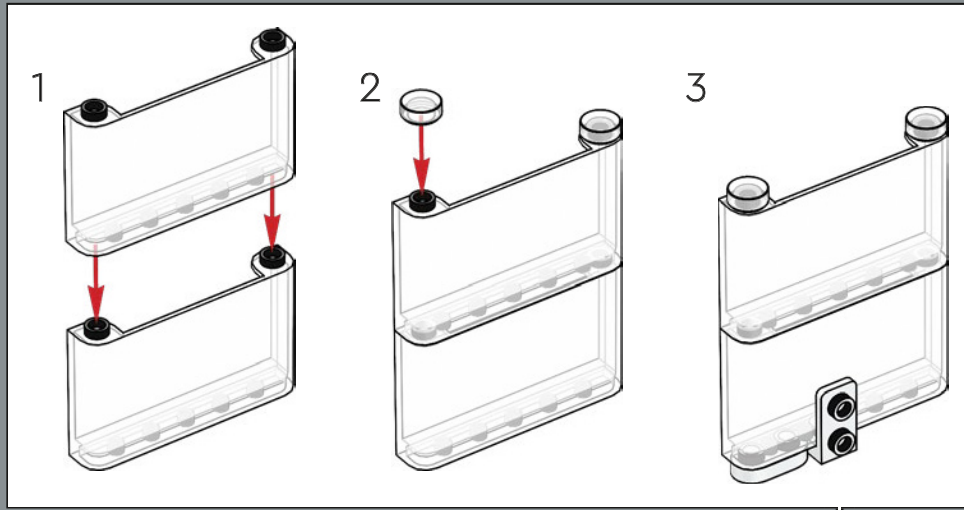

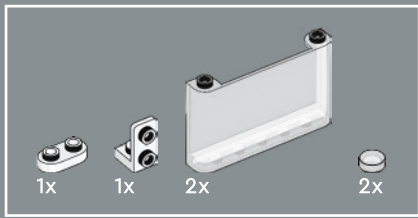

337

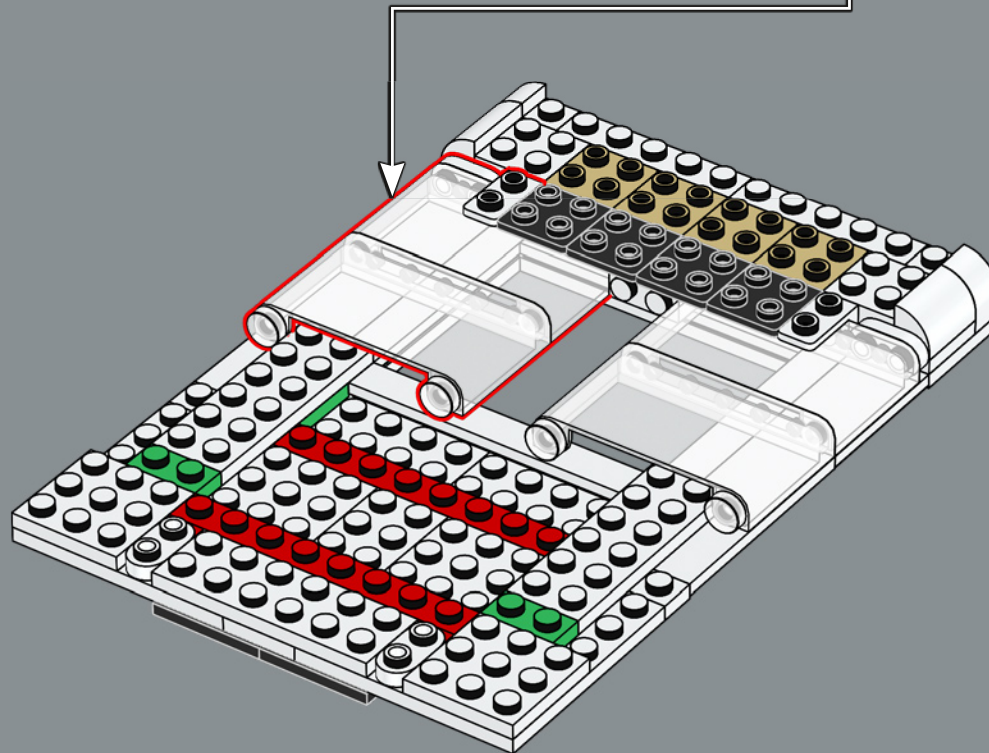
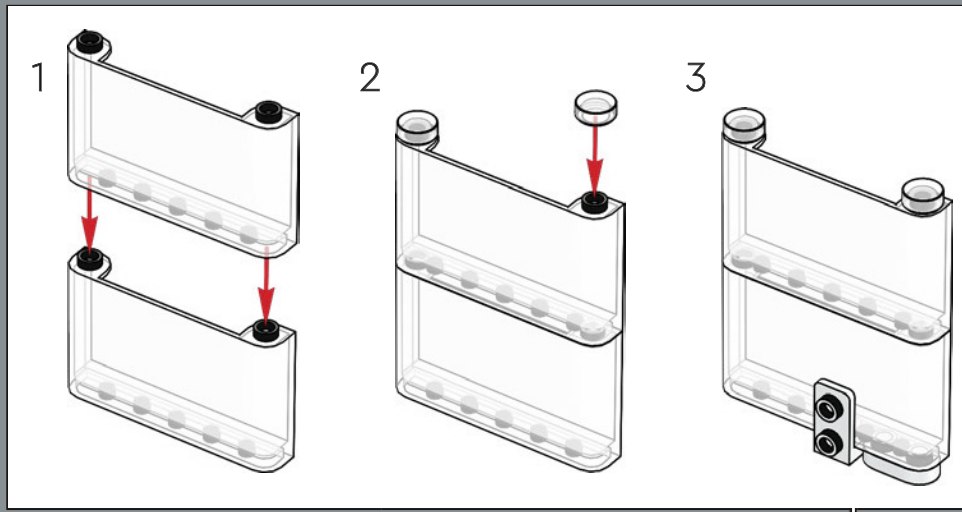

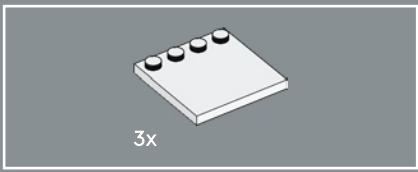

338

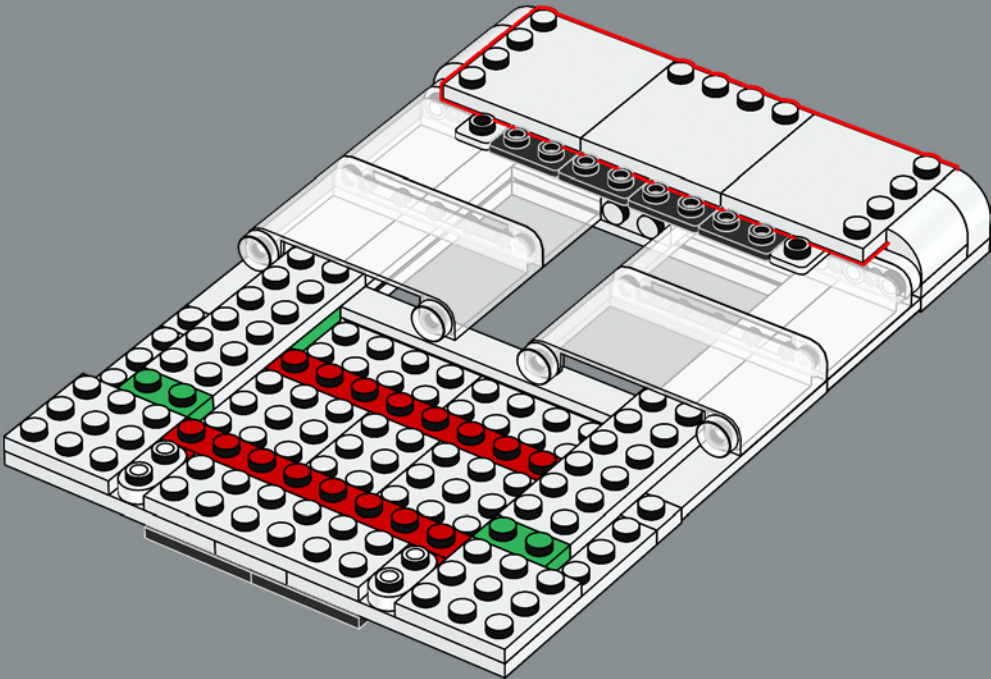

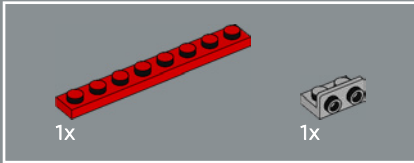
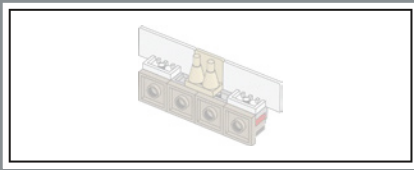

339

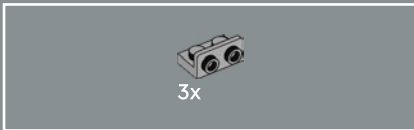
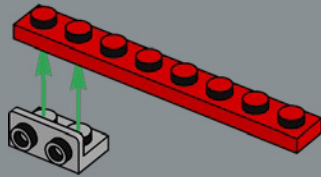

340

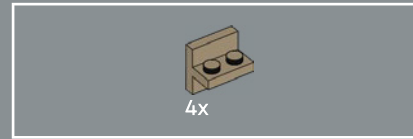
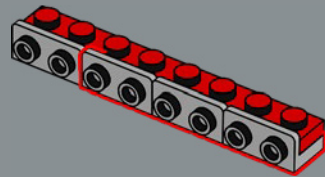

341

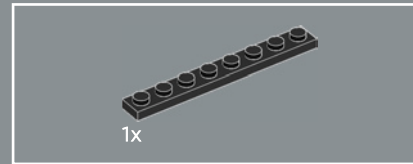
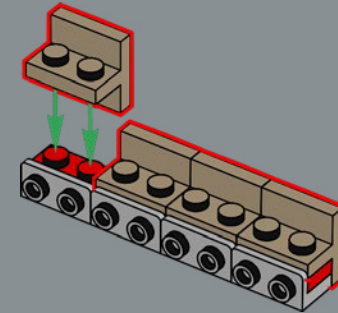

342

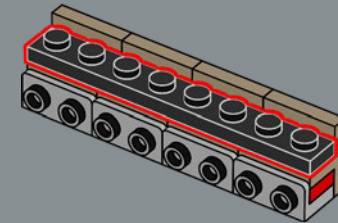

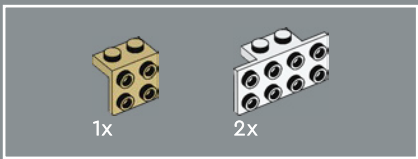

343

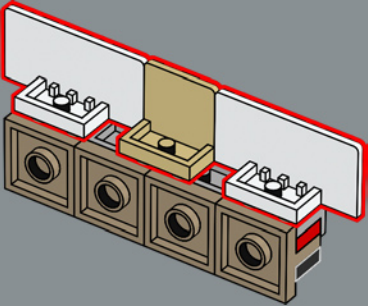

344

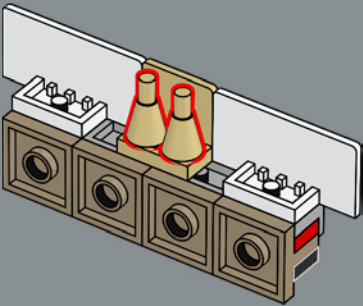

345

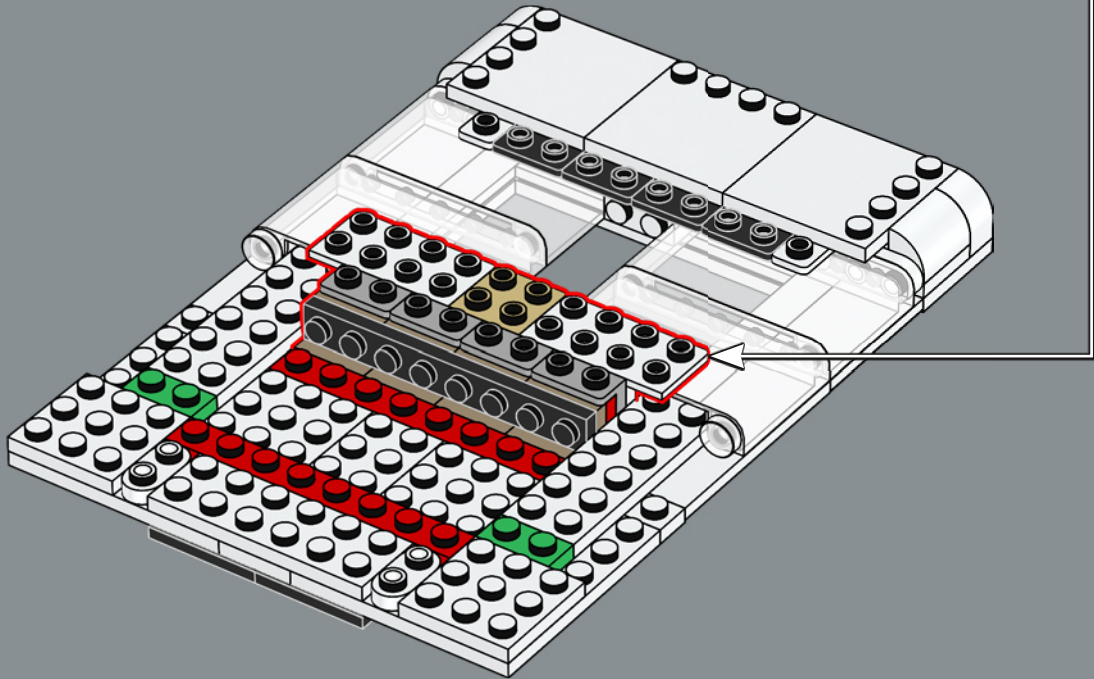

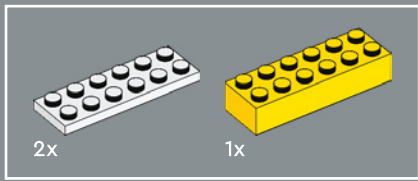

346

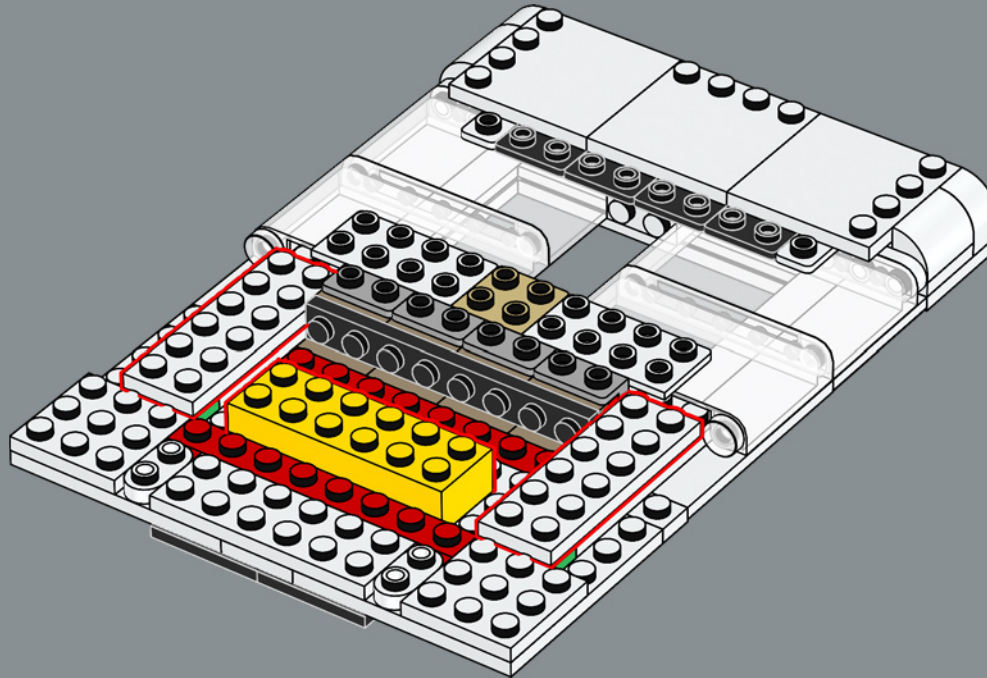

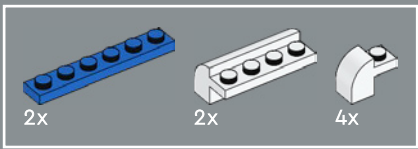

347

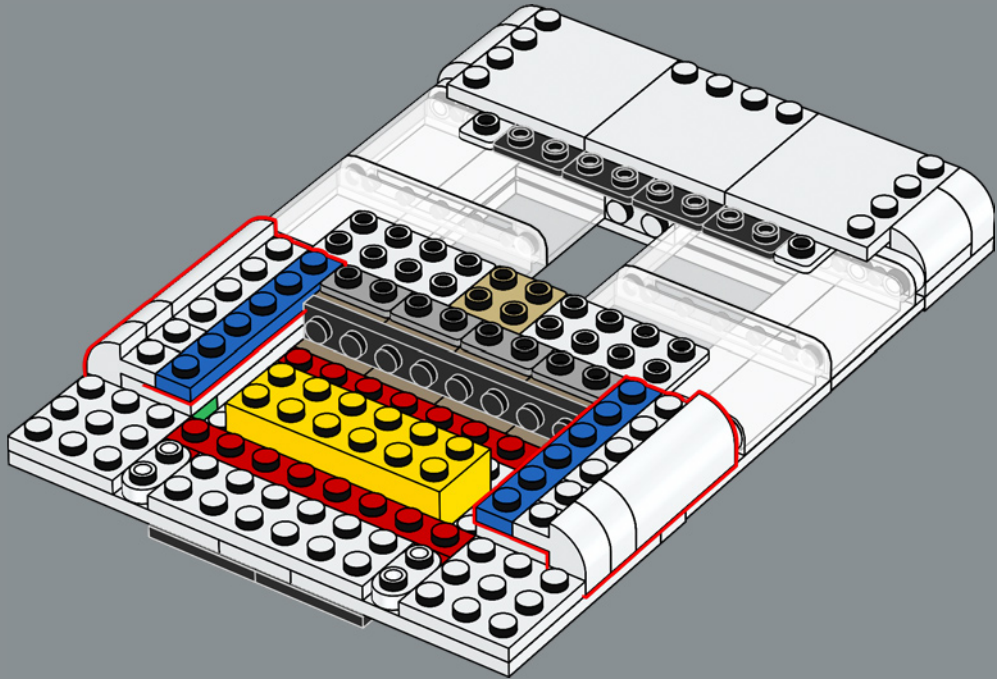

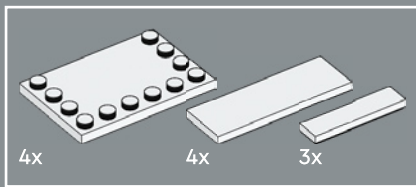

348

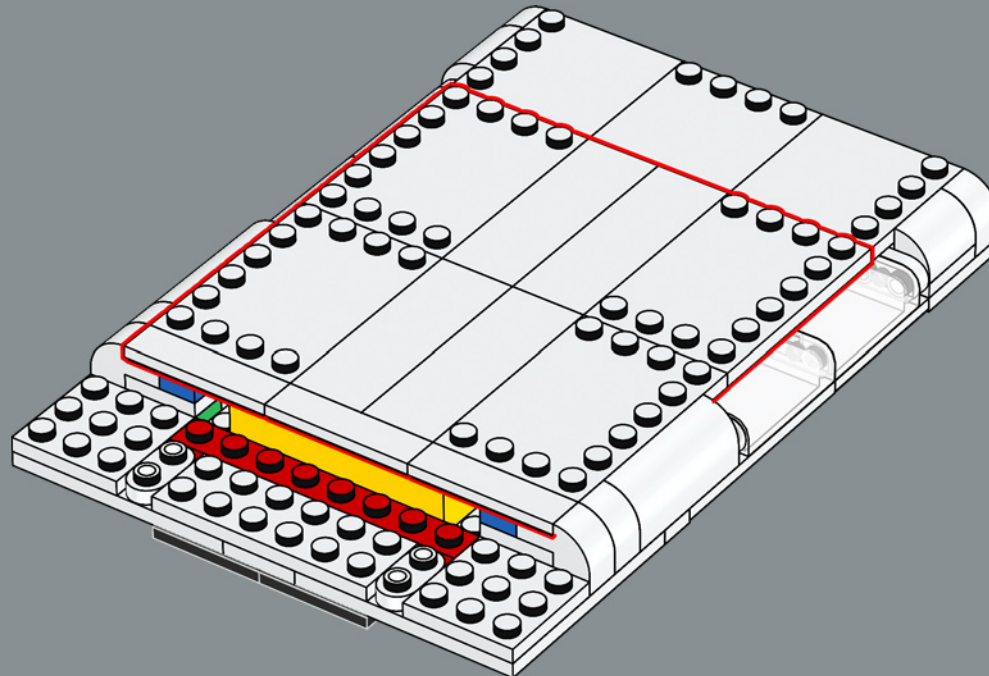

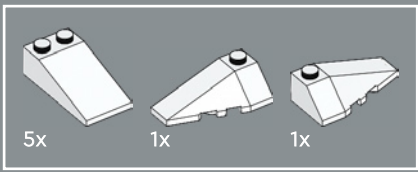

349

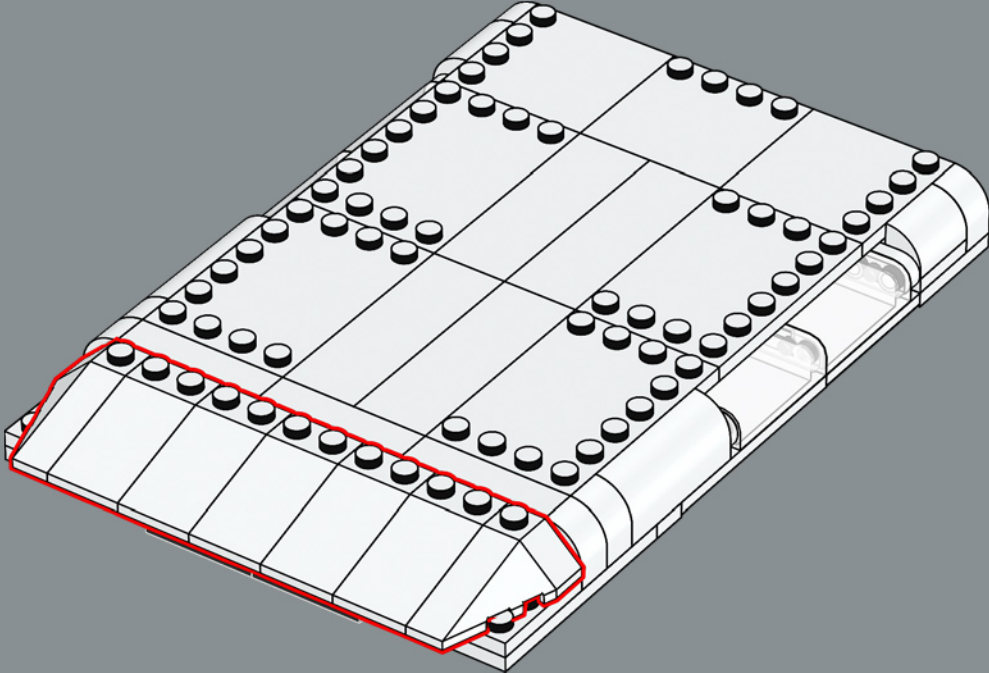

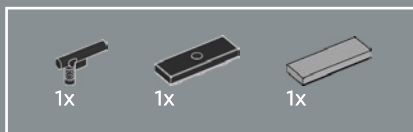

350

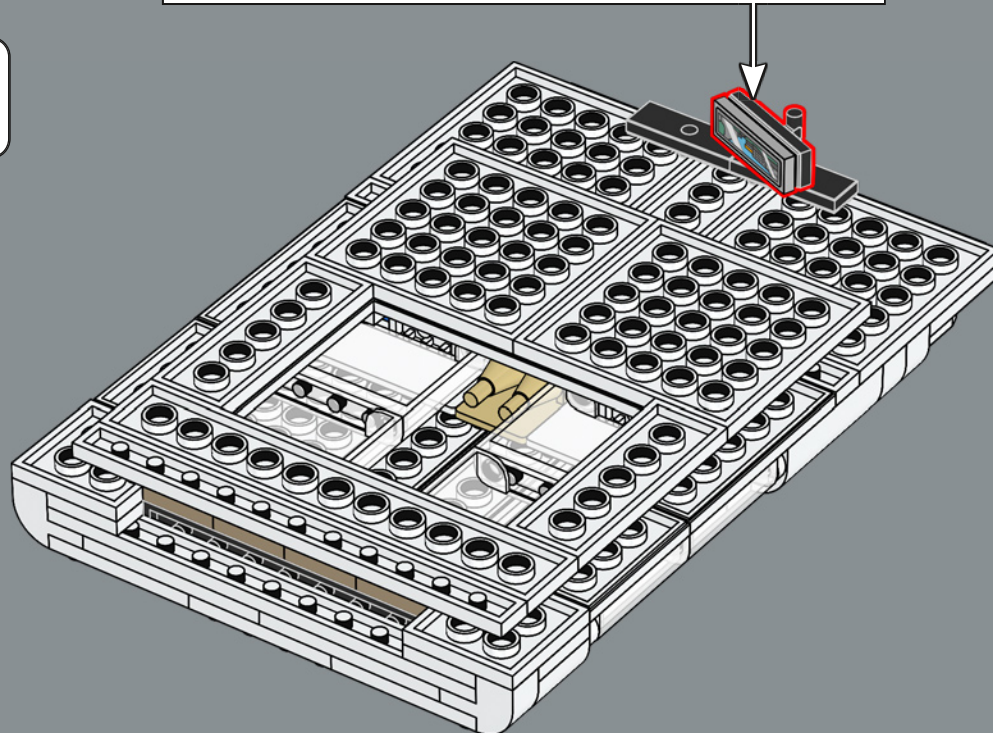
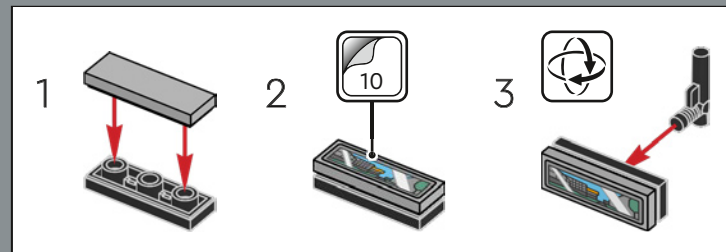

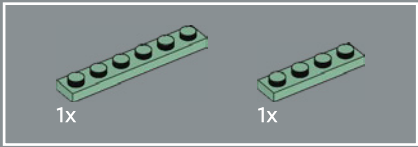
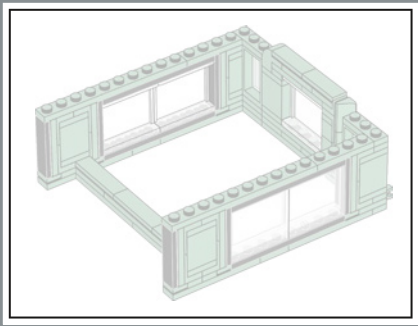

351

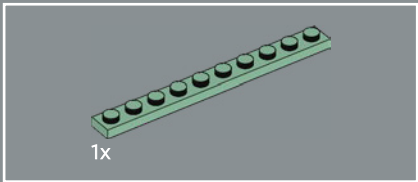
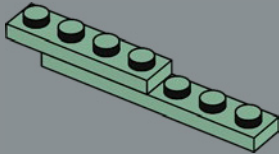

352

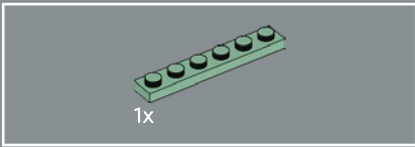
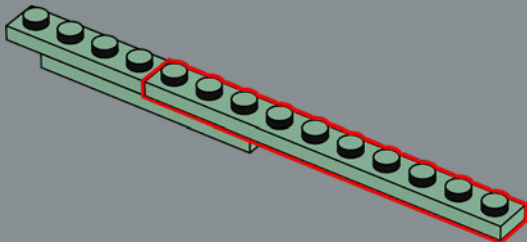

353

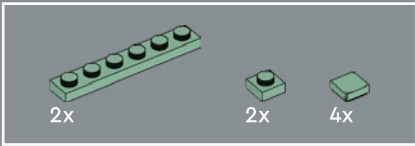
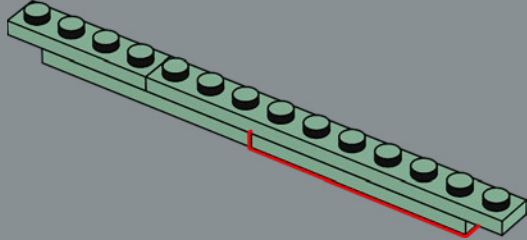

354

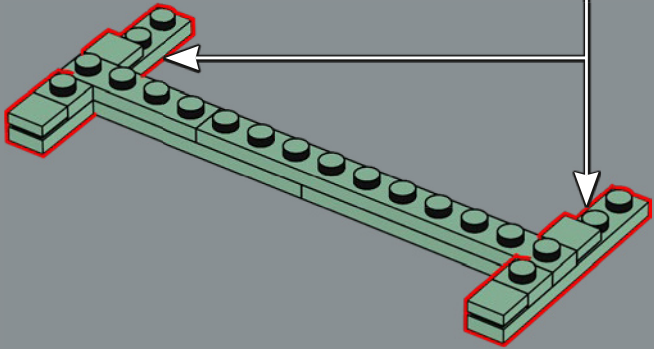
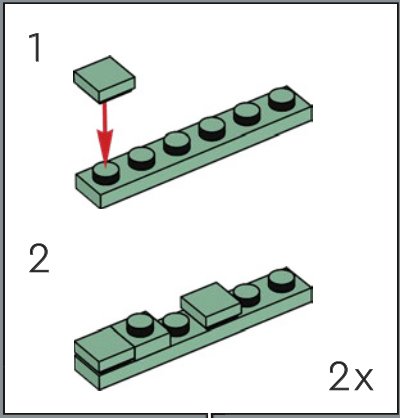

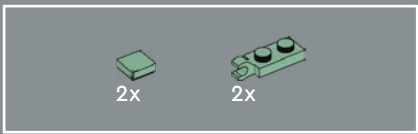

358

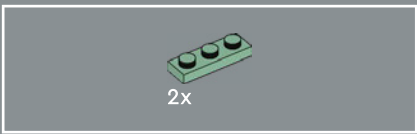
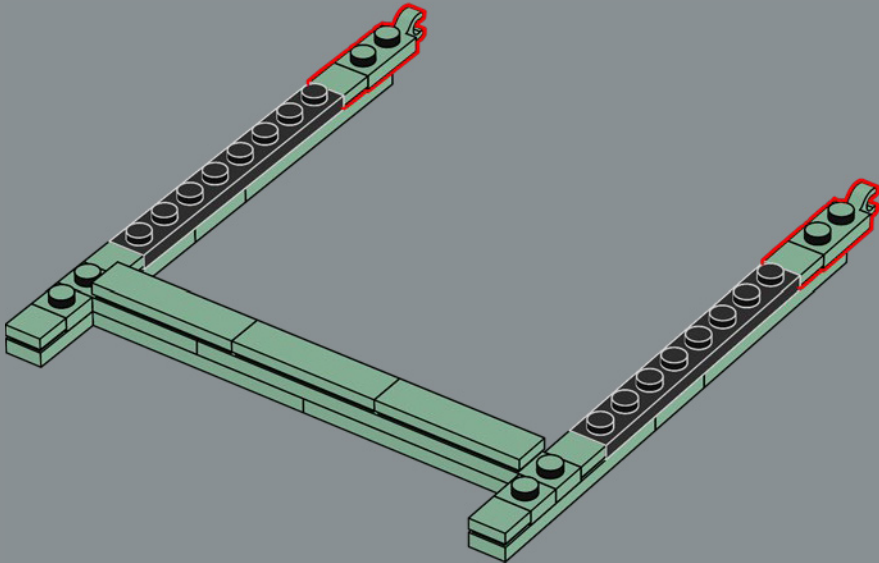

359

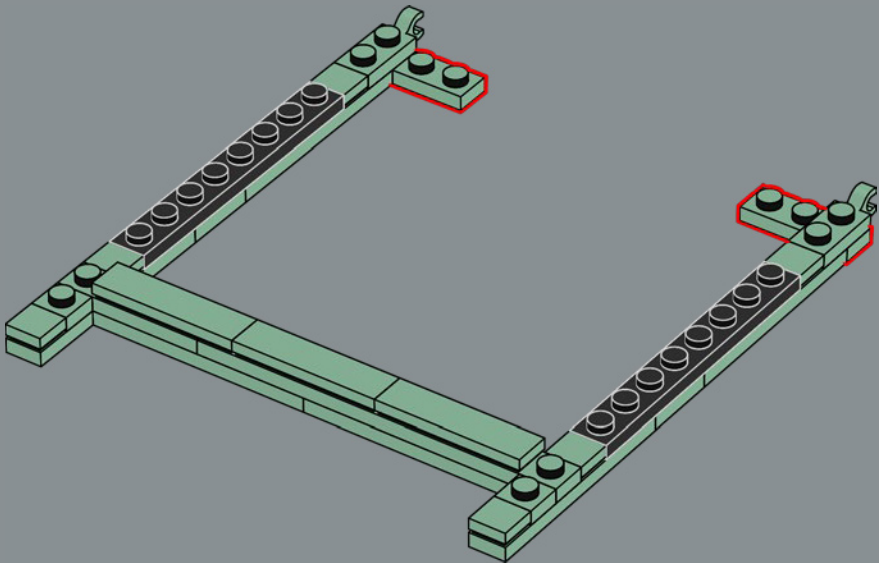

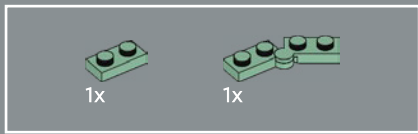

360

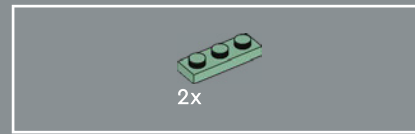
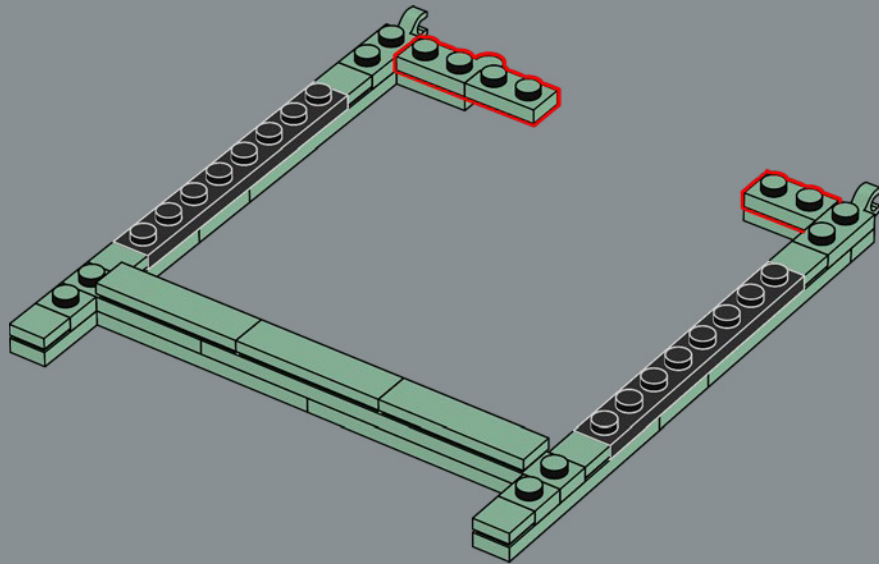

361

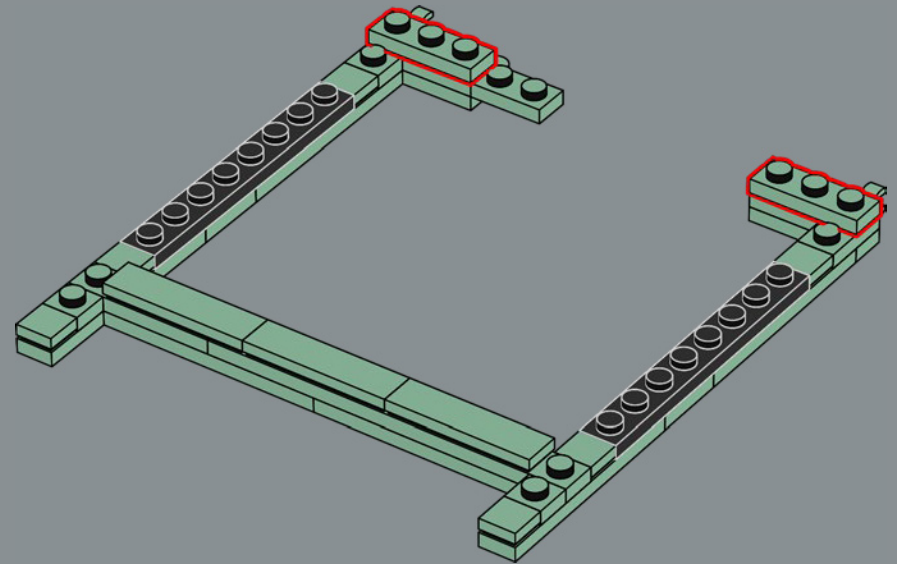

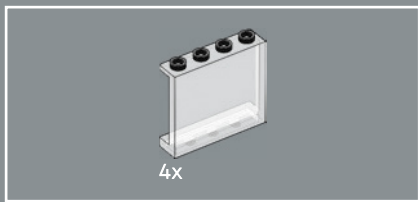

362

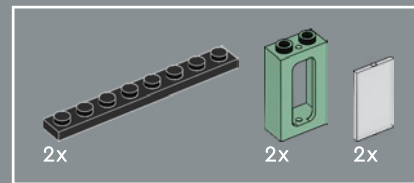
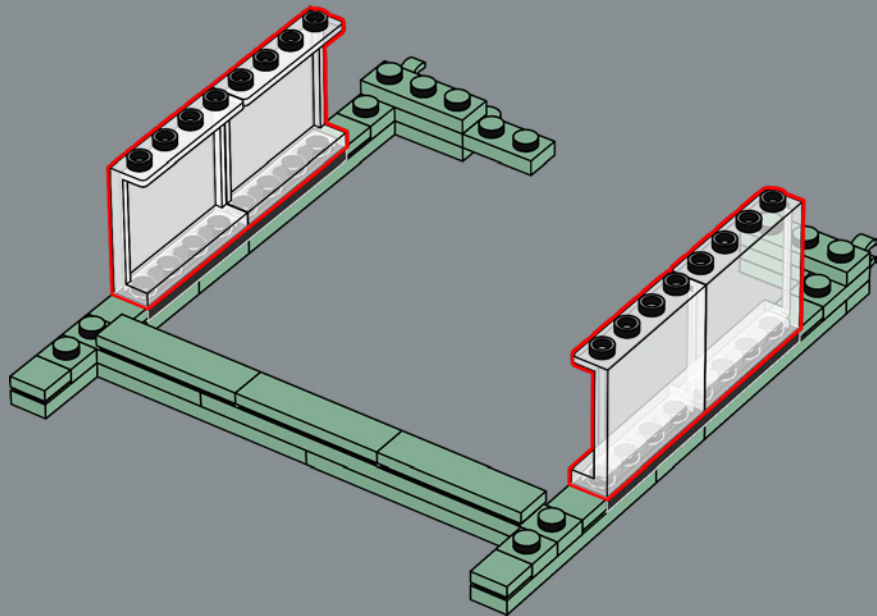

363

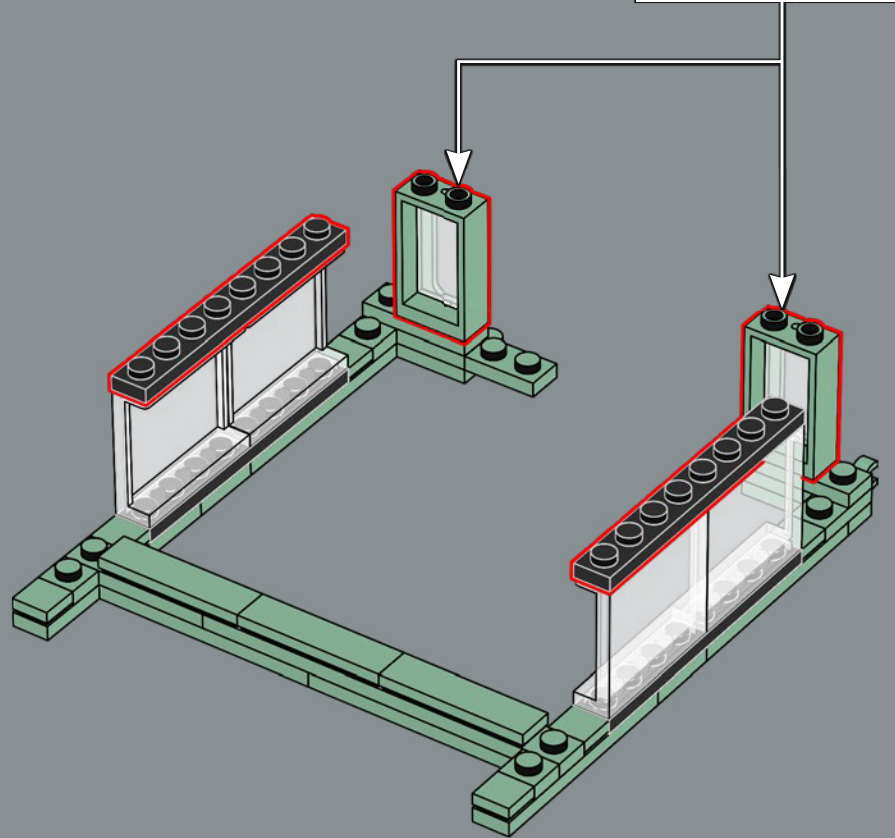
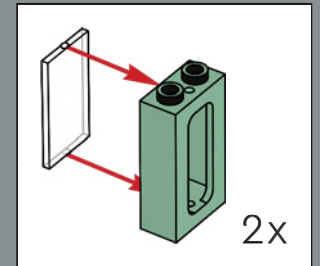

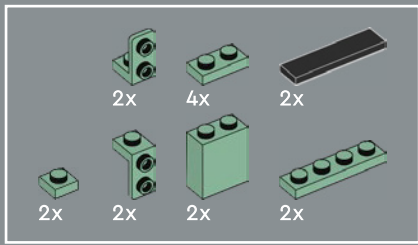

364

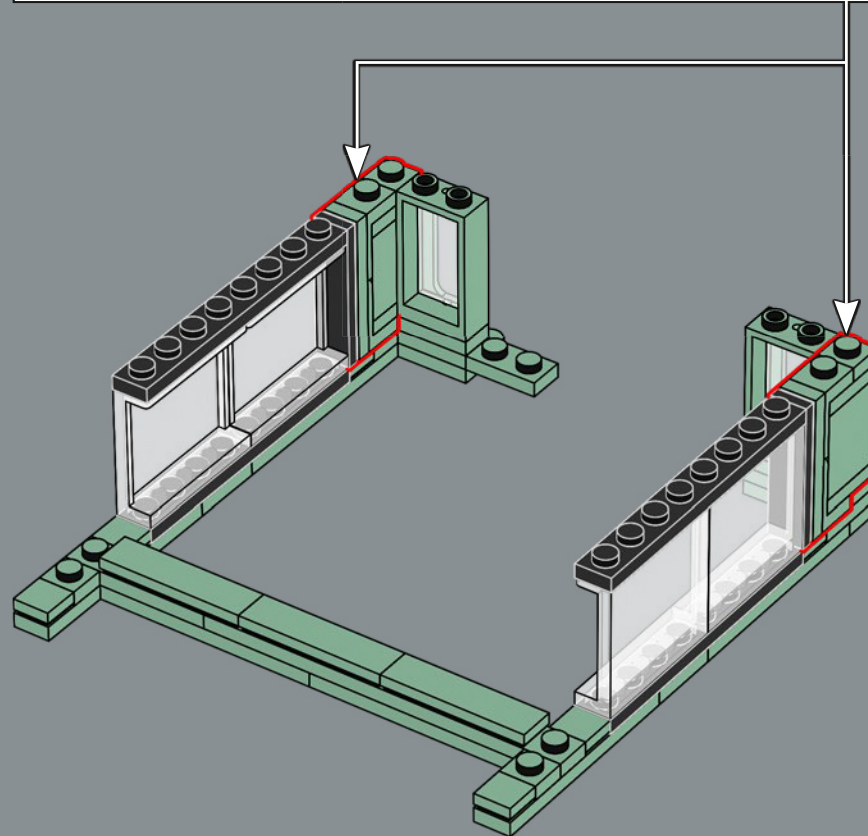
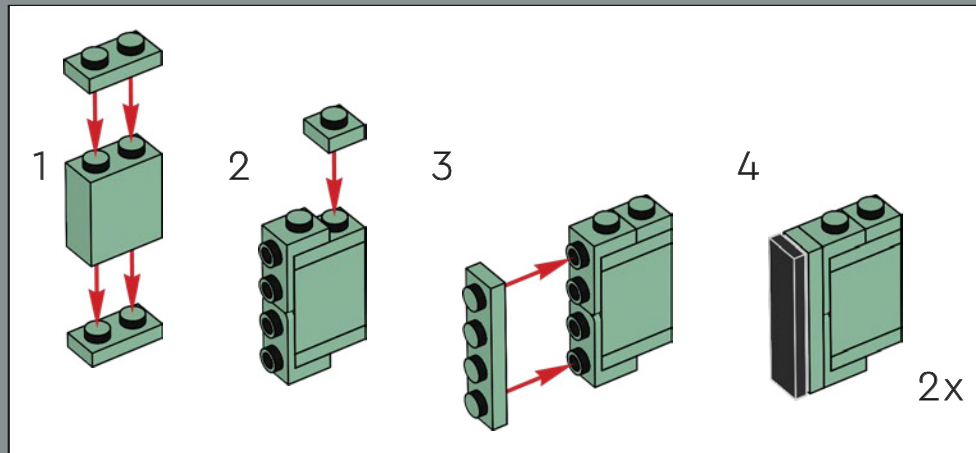

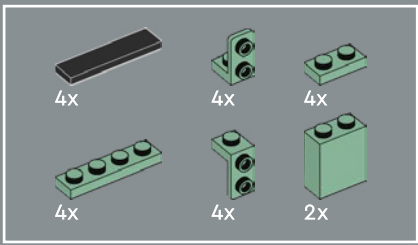

365

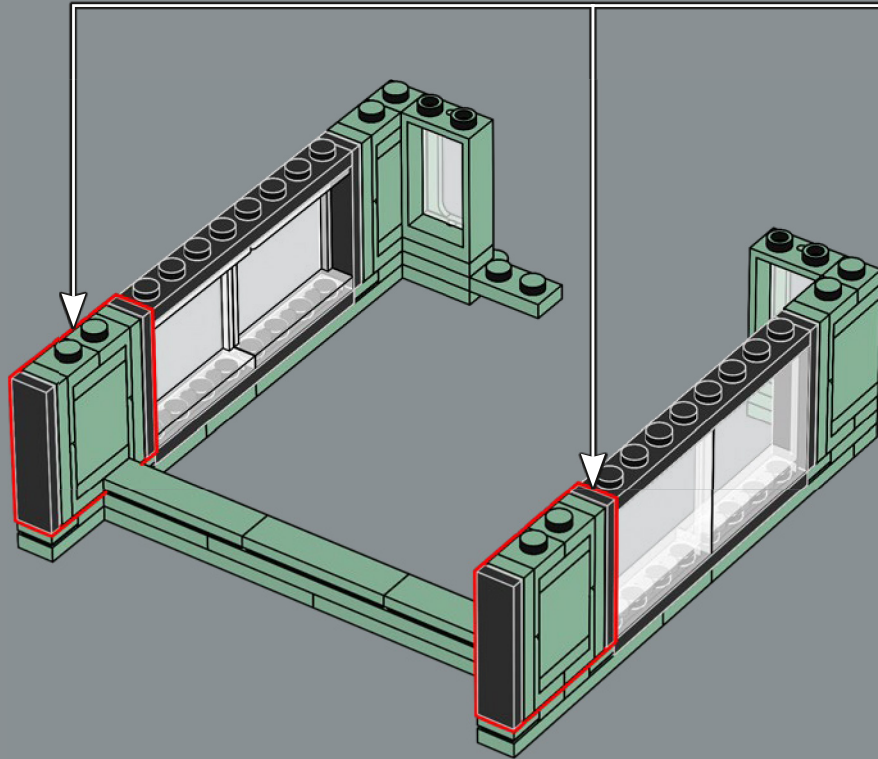
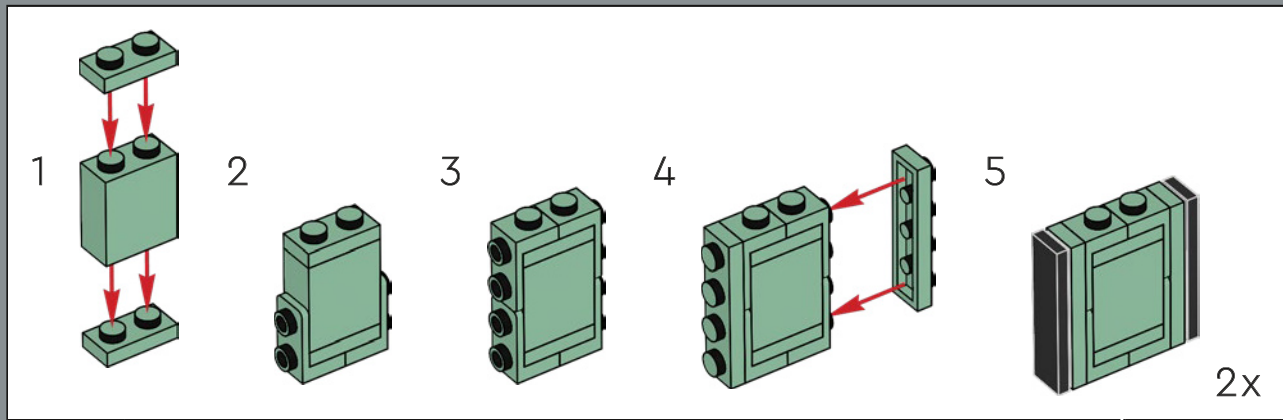

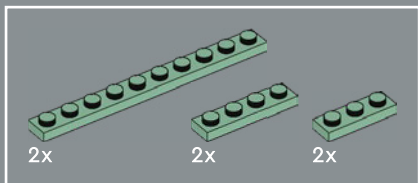

366

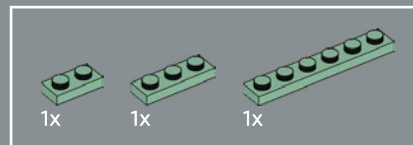
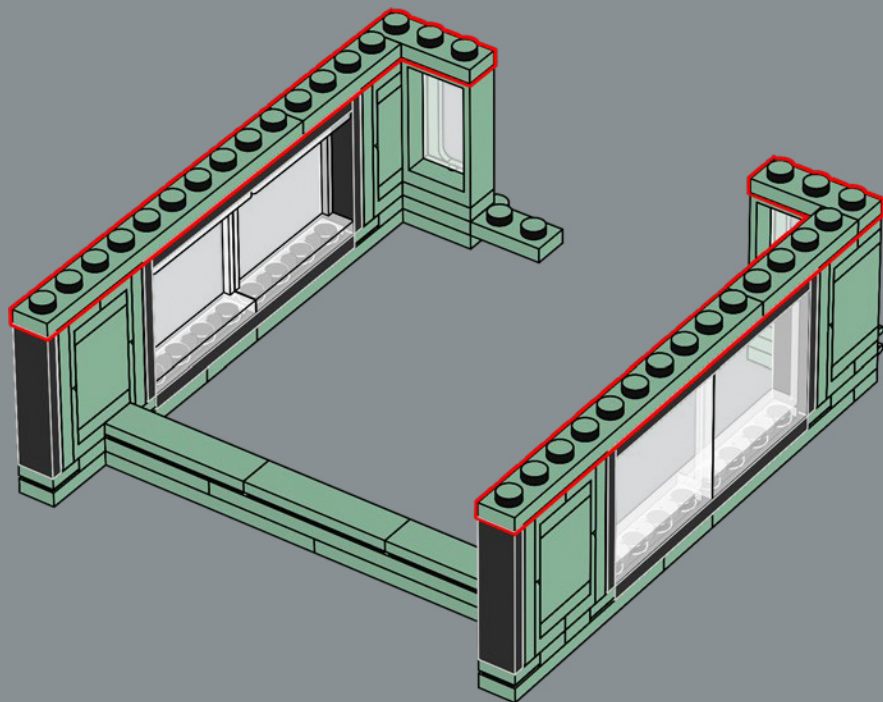

367

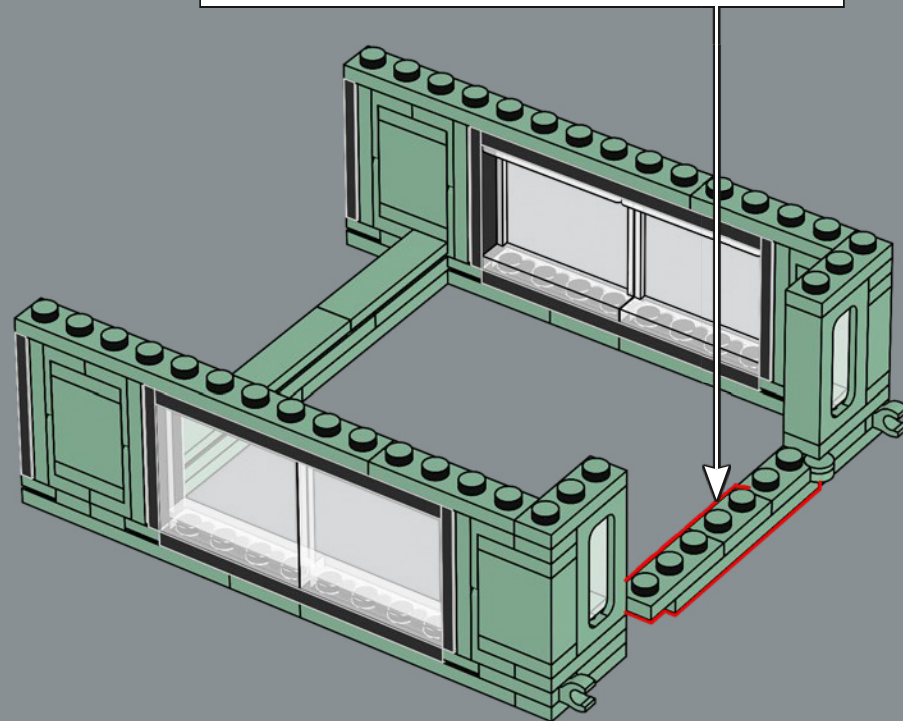
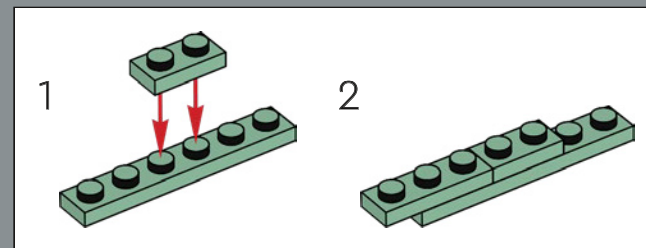

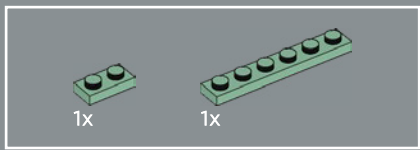

368

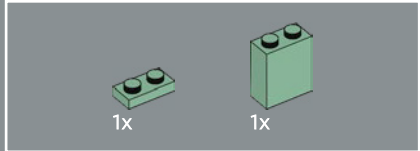
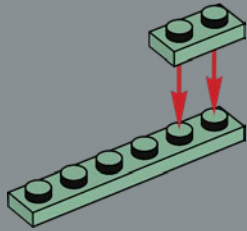

369

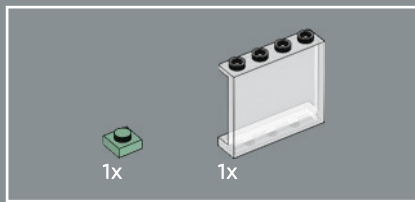
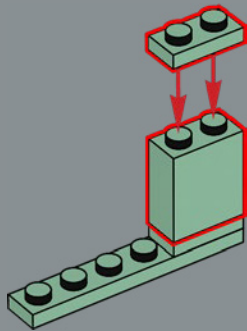

370

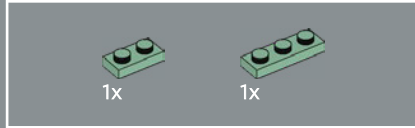
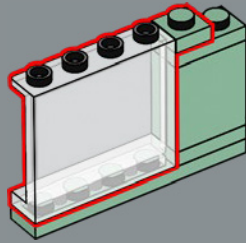

371

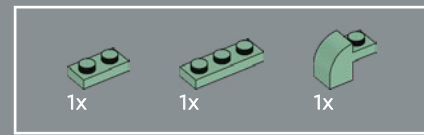
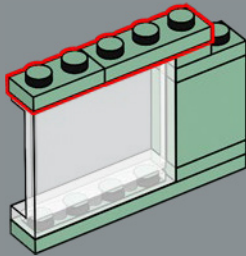

372

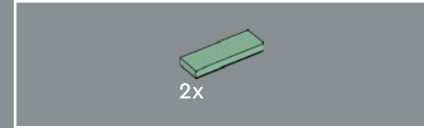
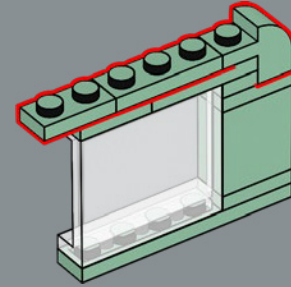

373

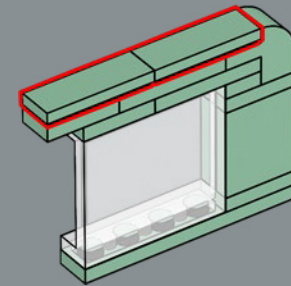

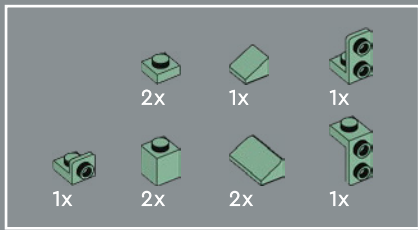

374

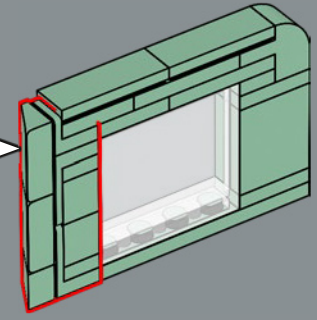
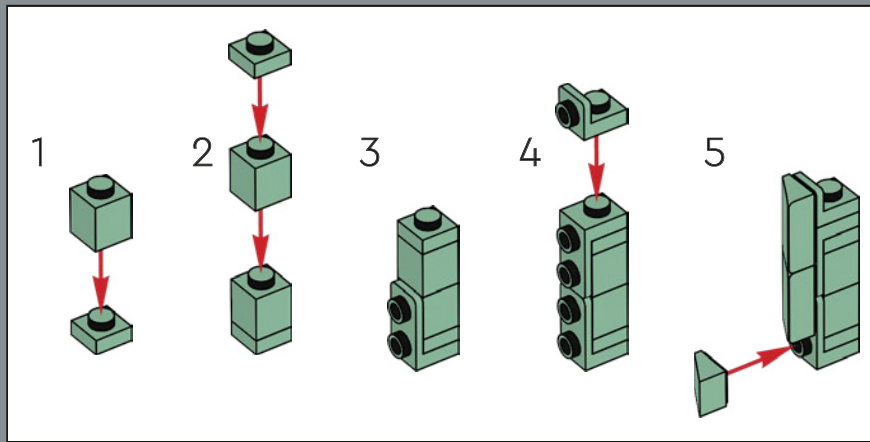

375

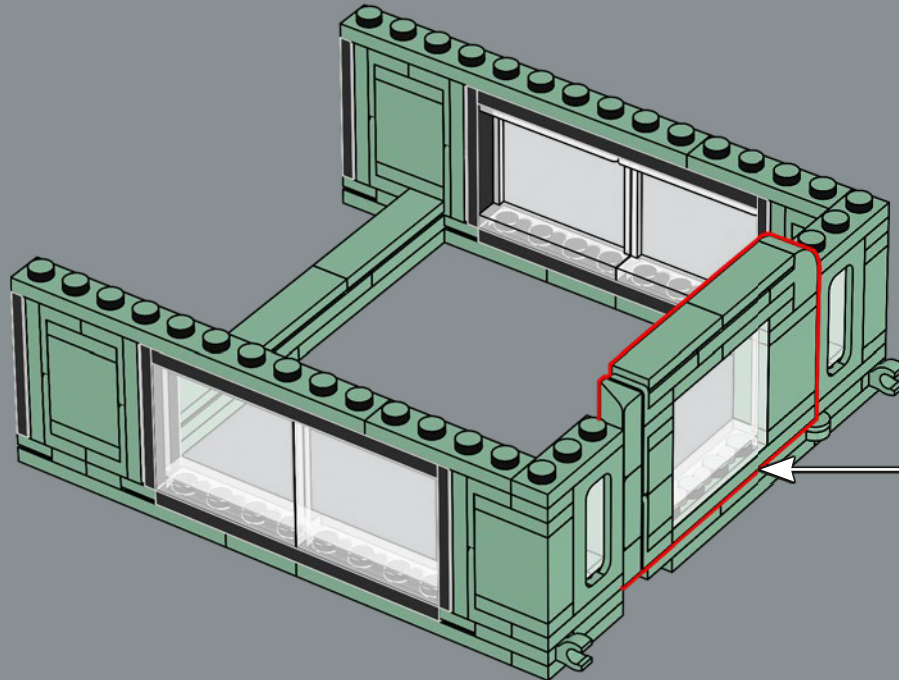



376

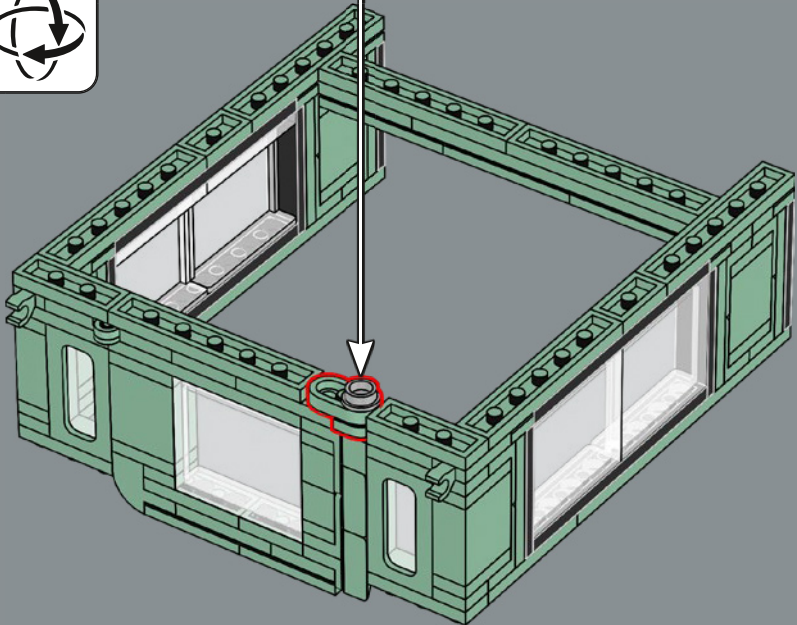
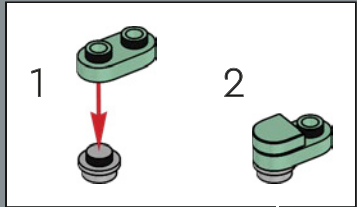

377

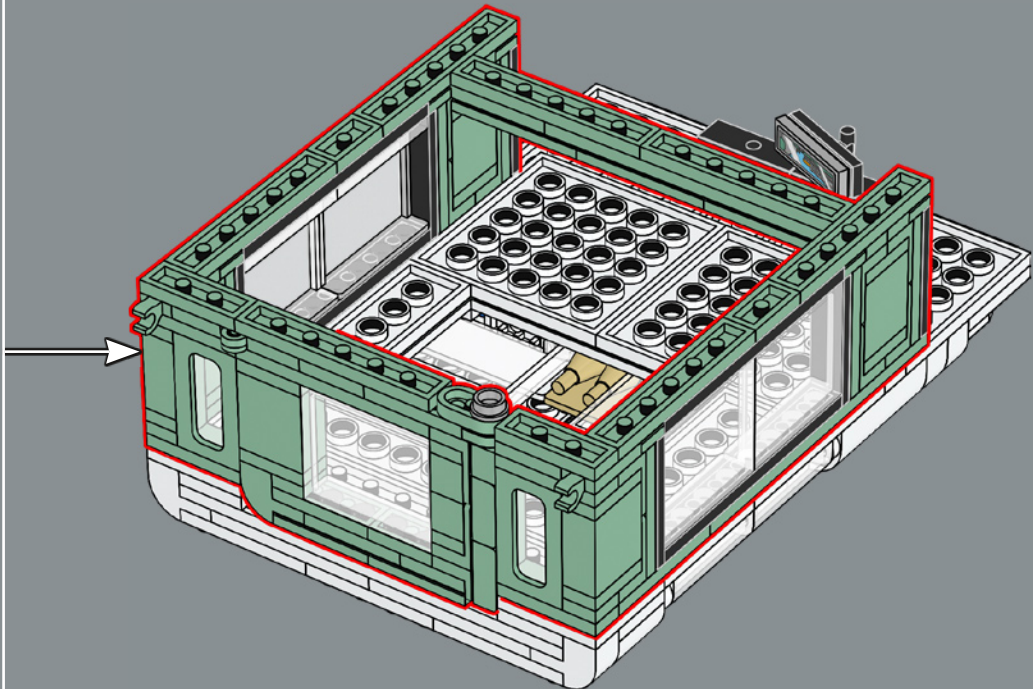

378

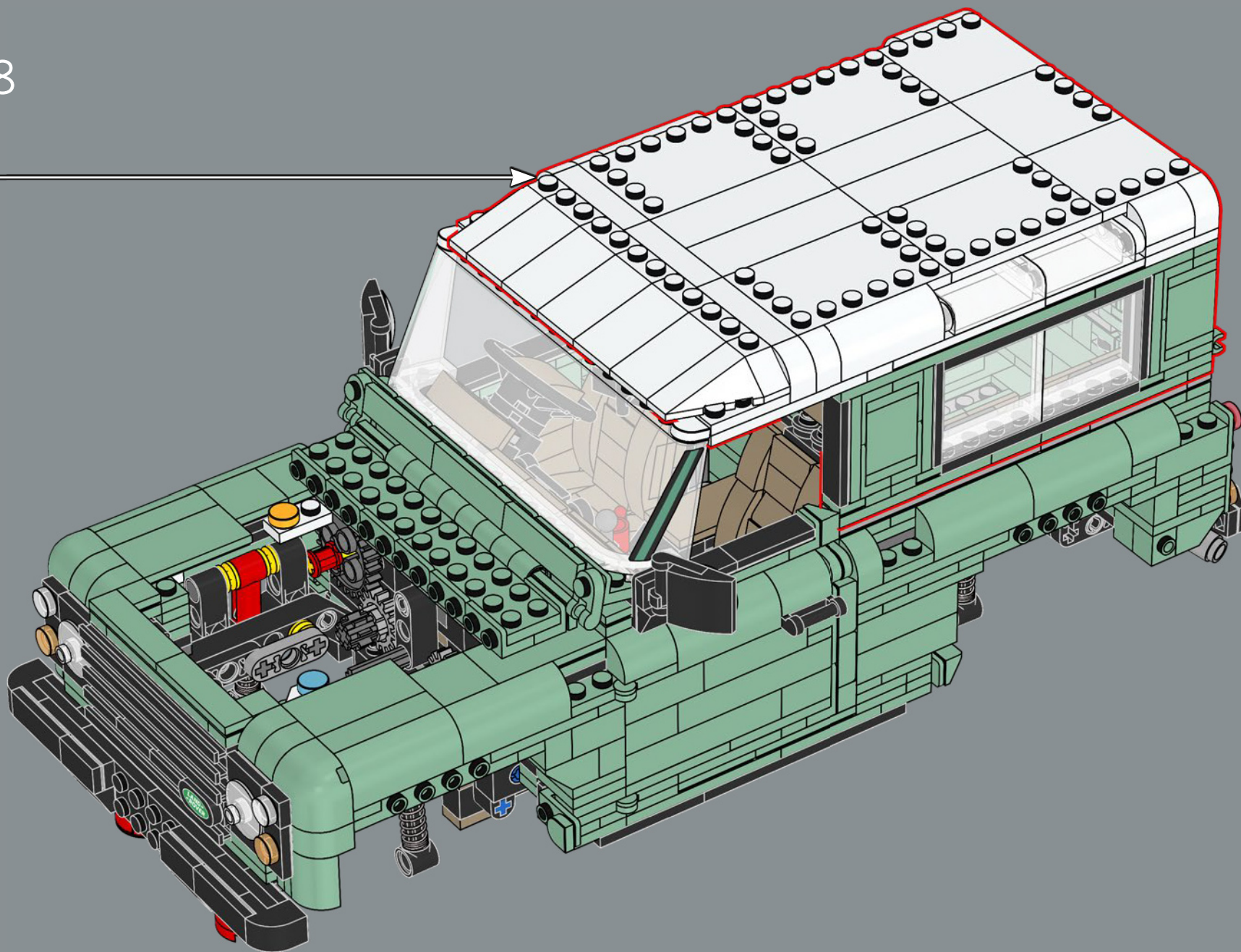

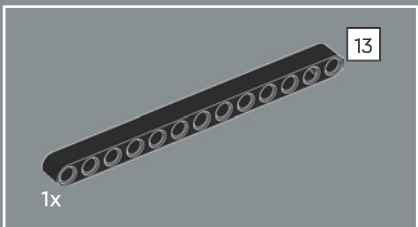
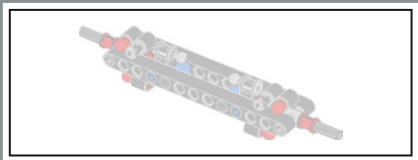

379

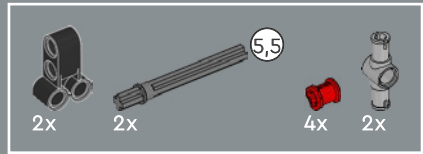
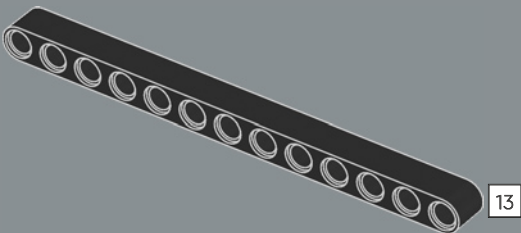

380

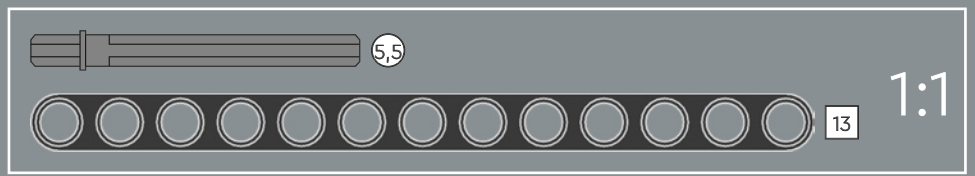
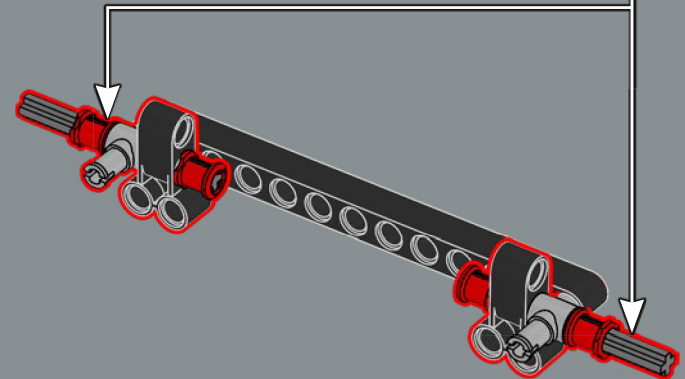
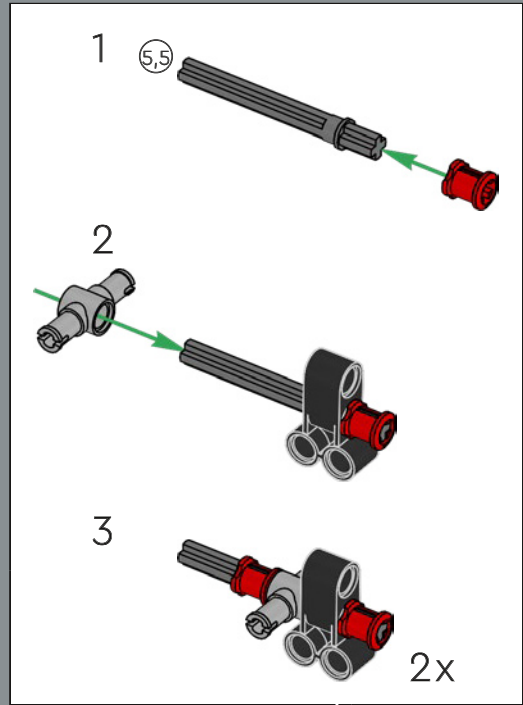

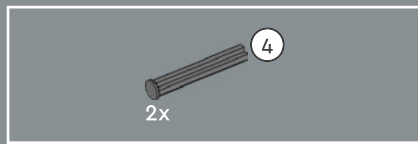

381

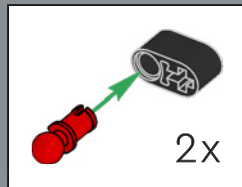
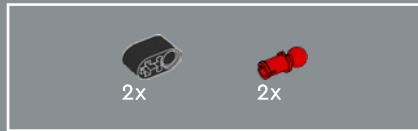
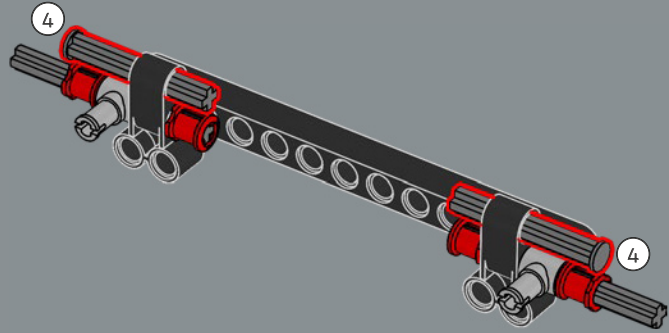

382

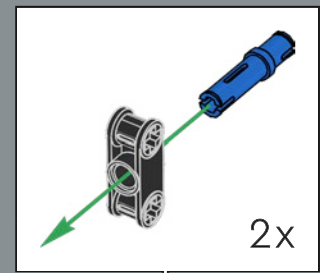
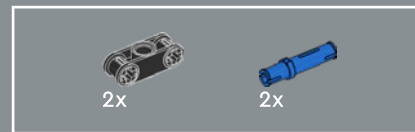
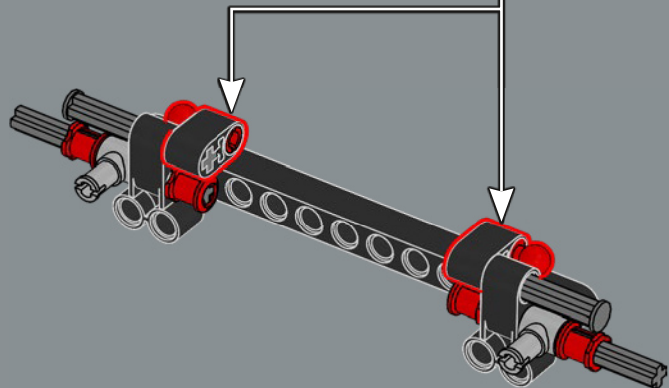

383

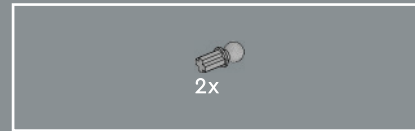
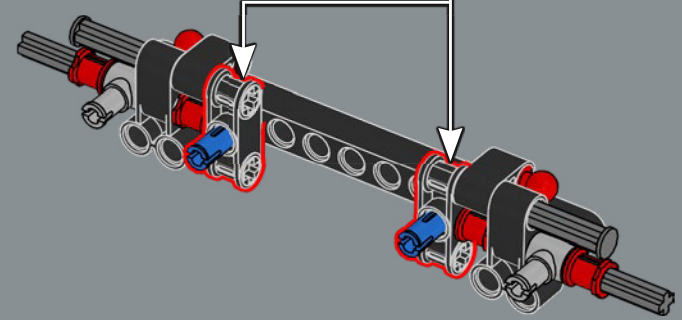

384

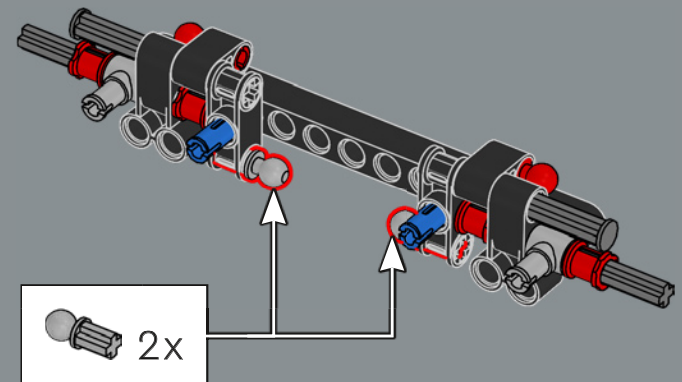



385

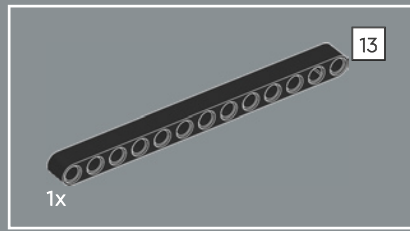
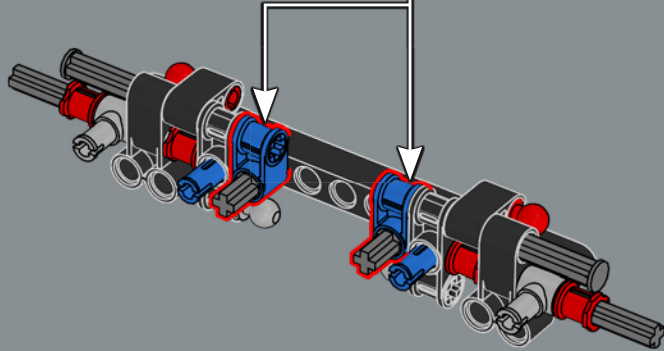
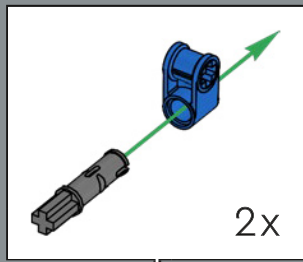

387

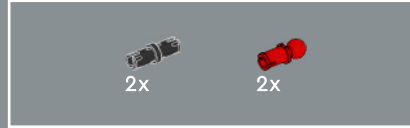
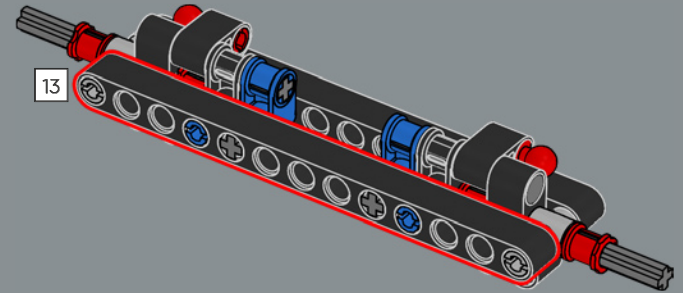

388

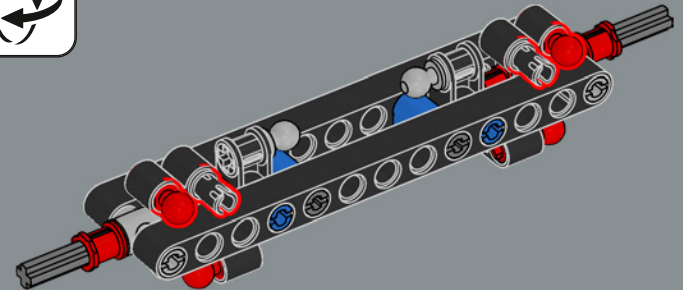
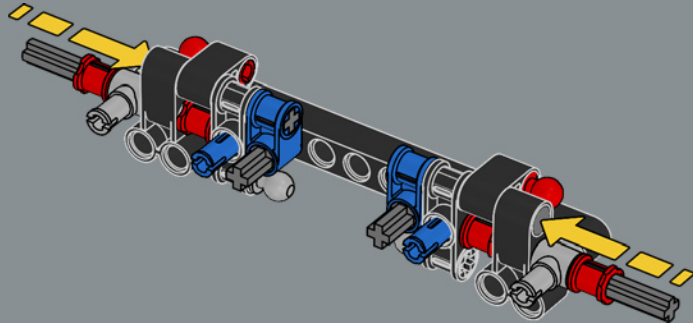

389

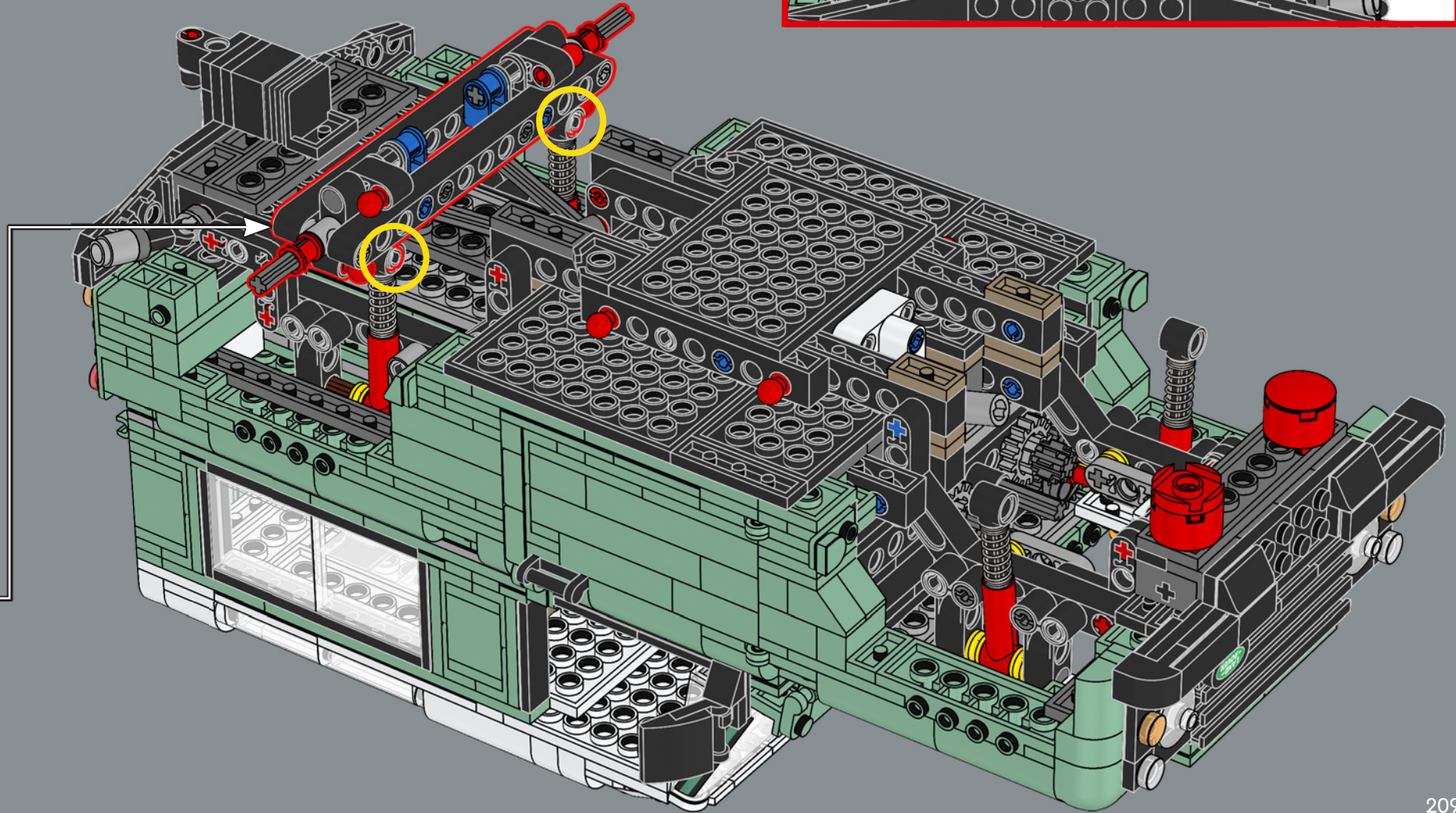
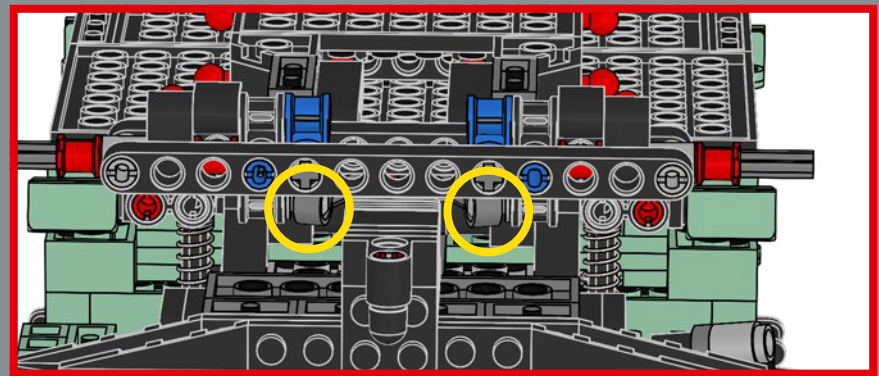

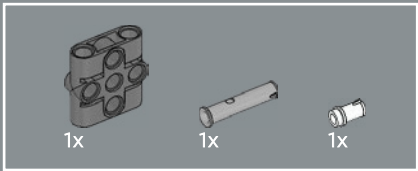

390

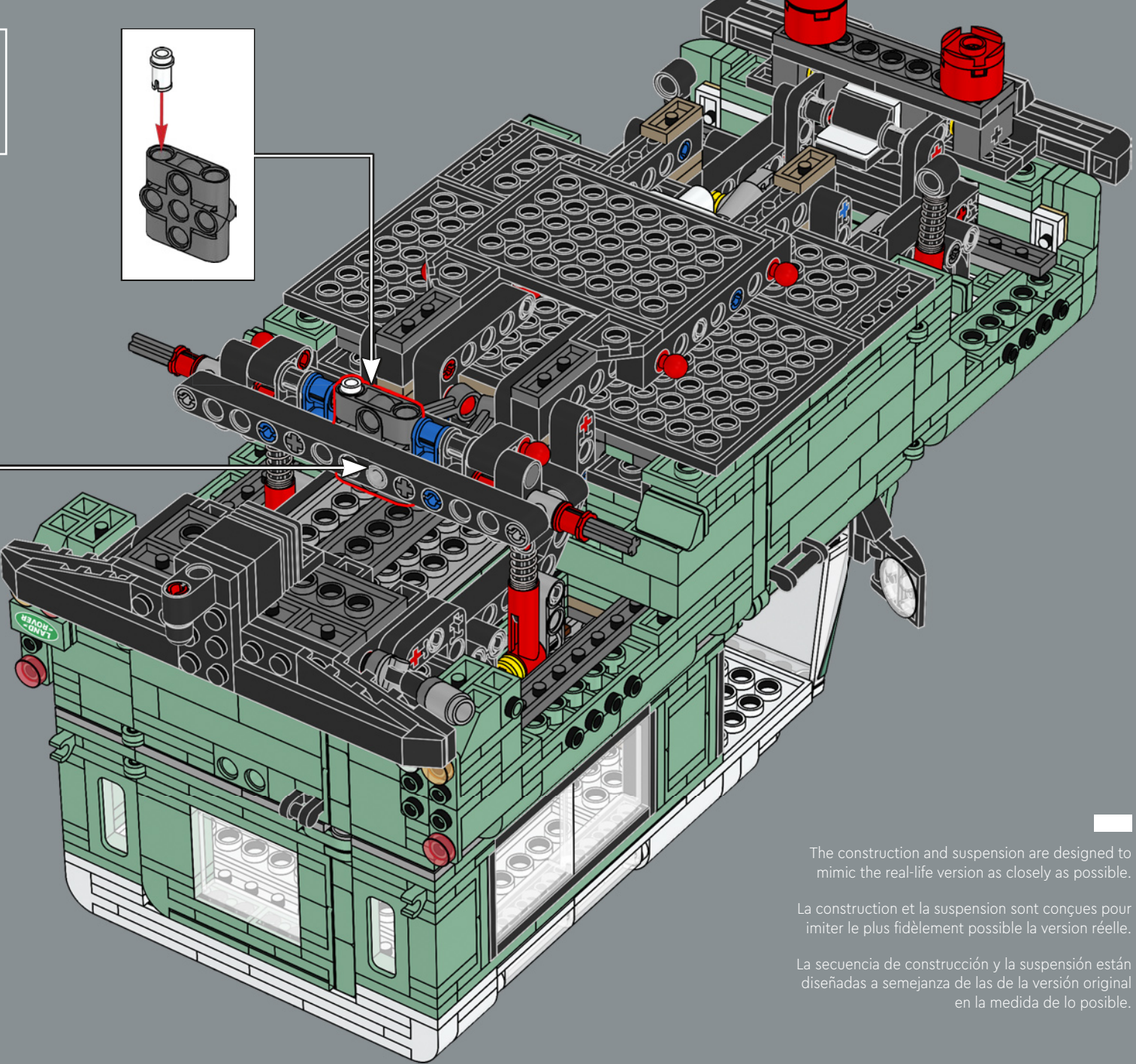
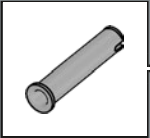
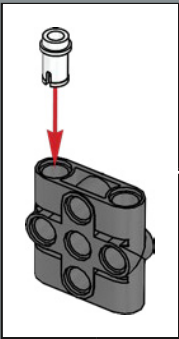

The construction and suspension are designed to mimic the real-life version as closely as possible.

La construction et la suspension sont conçues pour imiter le plus fidèlement possible la version réelle.

La secuencia de construcción y la suspensión están diseñadas a semejanza de las de la versión original en la medida de lo posible.

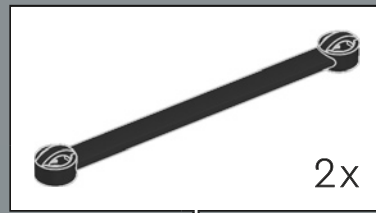
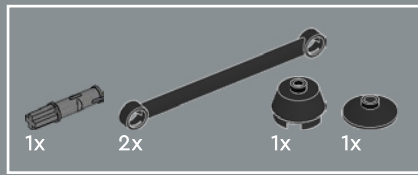

391

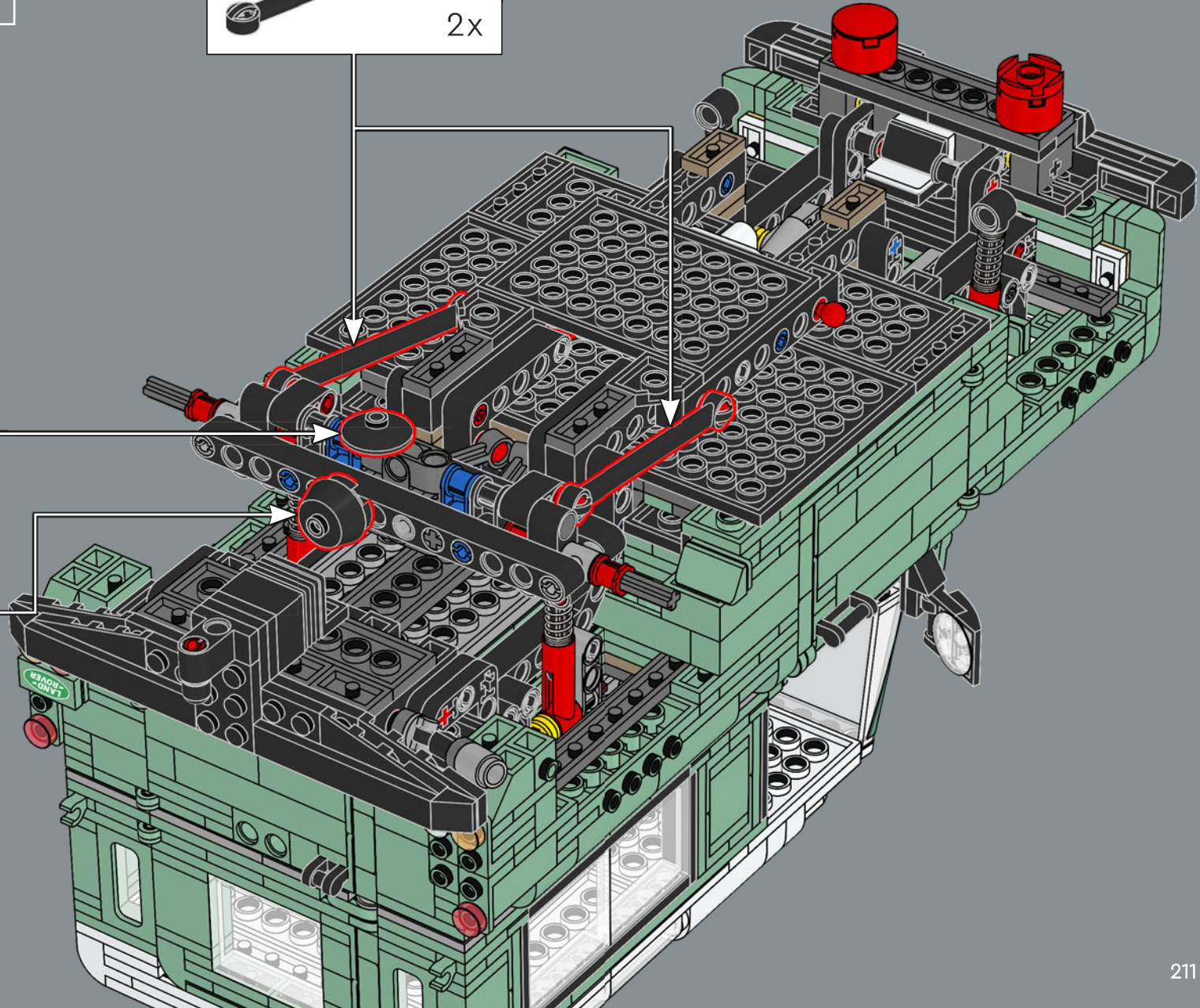
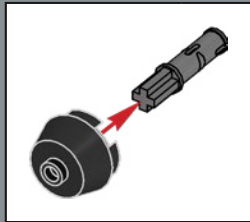

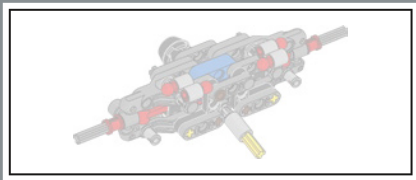

392

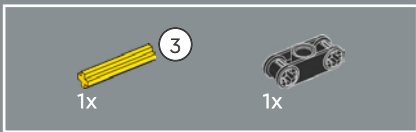
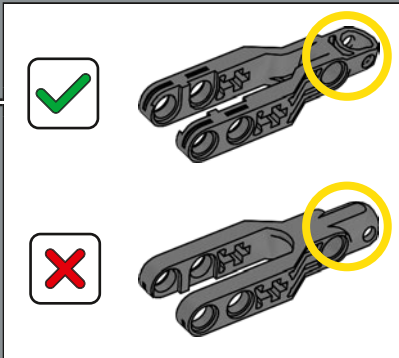

393

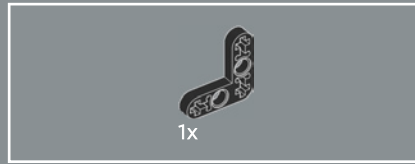
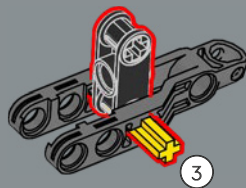

394

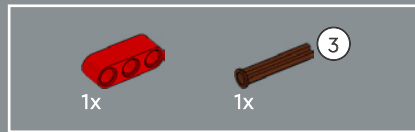
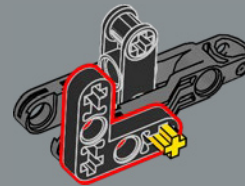

395

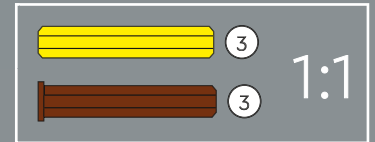
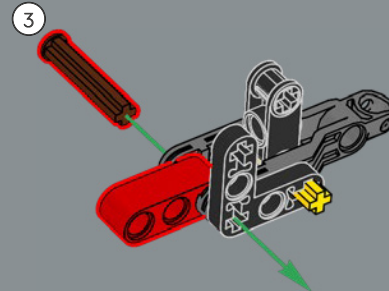

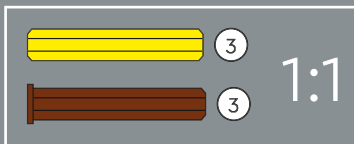
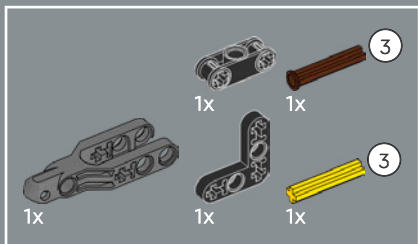

396

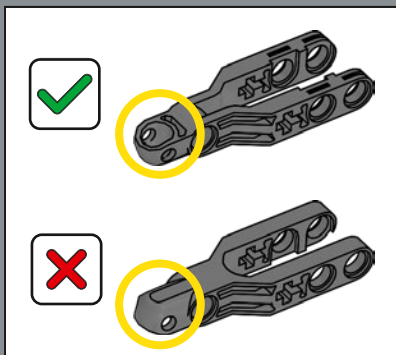

1

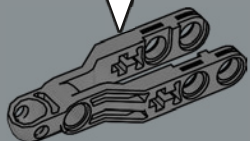

2

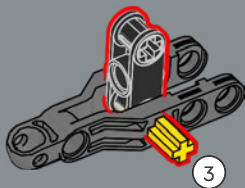

3

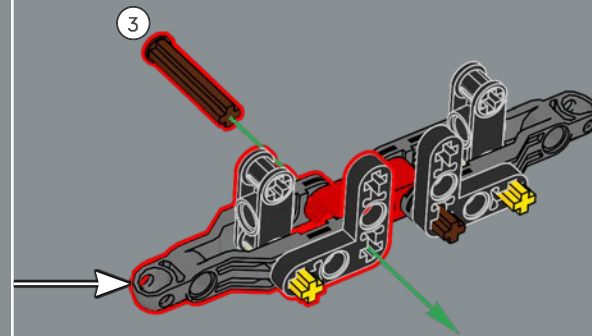
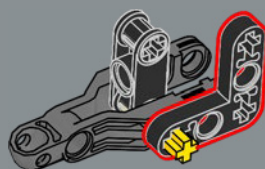



2x

397

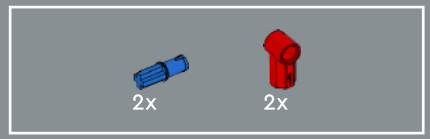
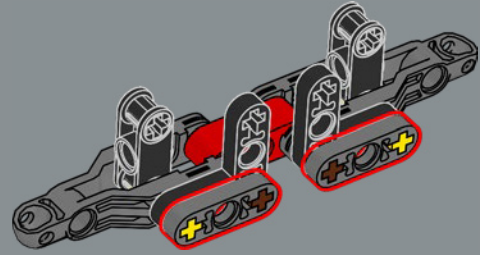

2x

2x

398

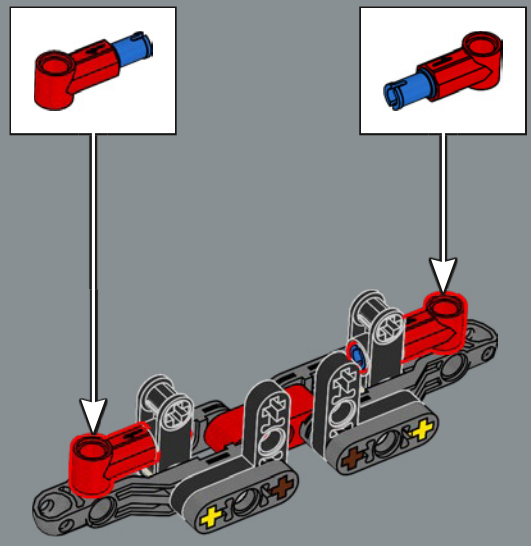

2x

399

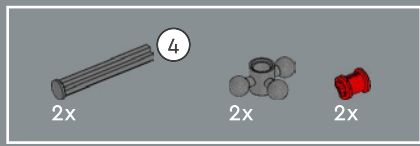
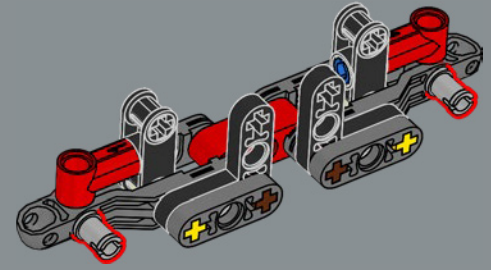

2x

2x

2x



4

1:1

400

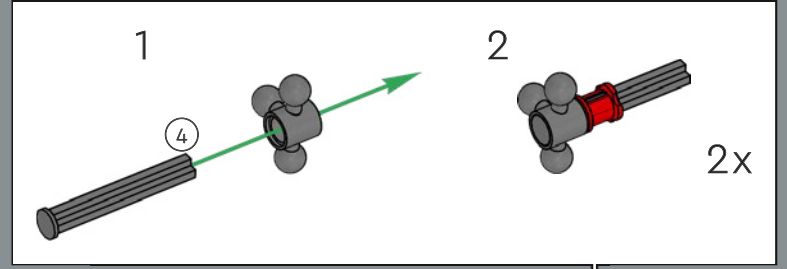

1

2

4

2x

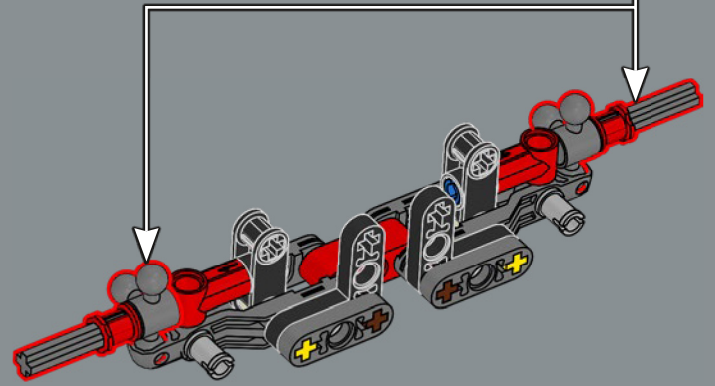

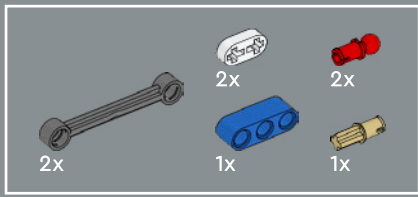

401

1

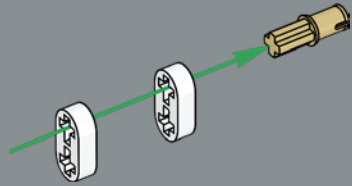

2

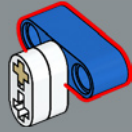

3

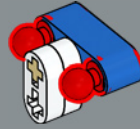

4

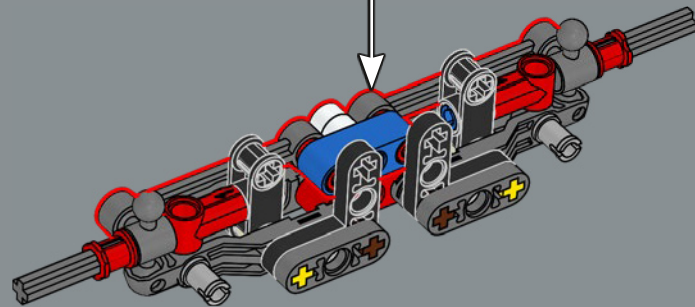
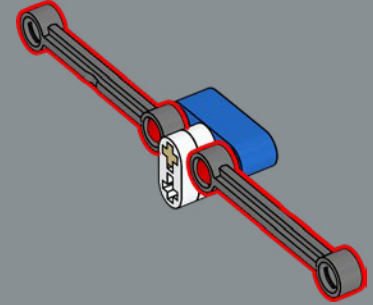

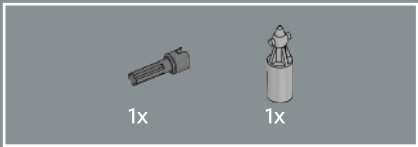

402

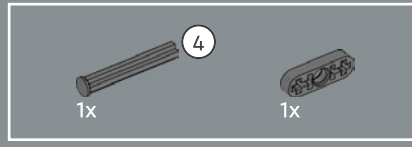
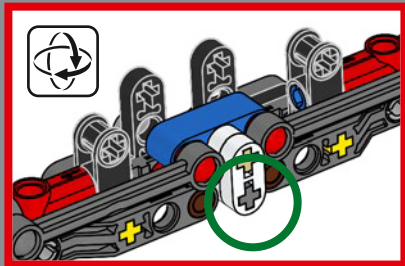
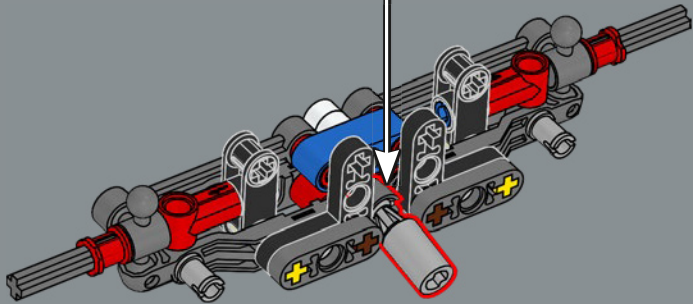
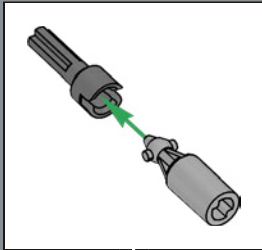

403

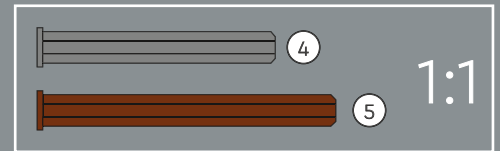
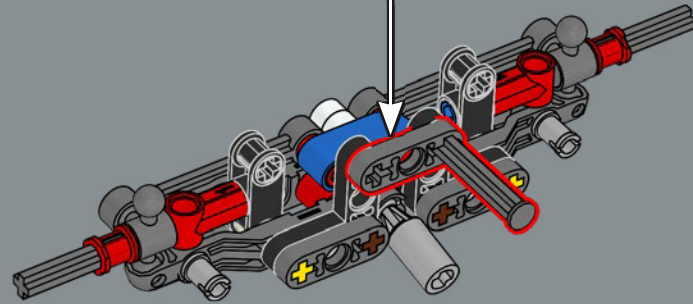
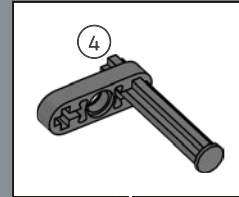

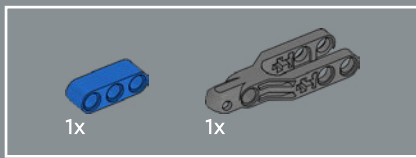

404

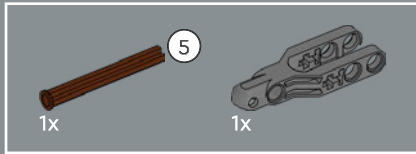
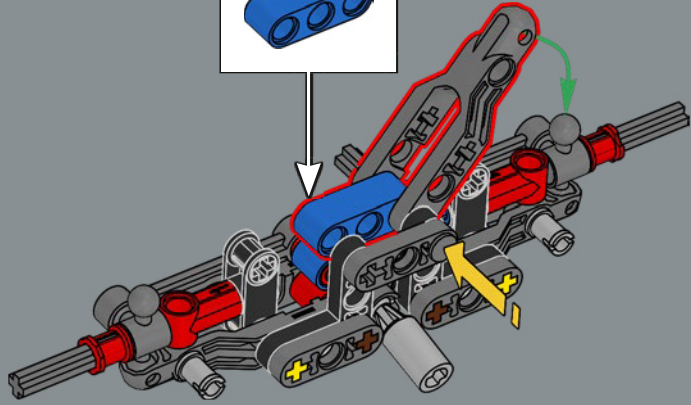
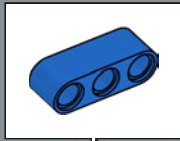

405

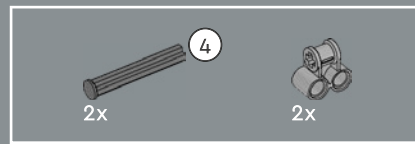
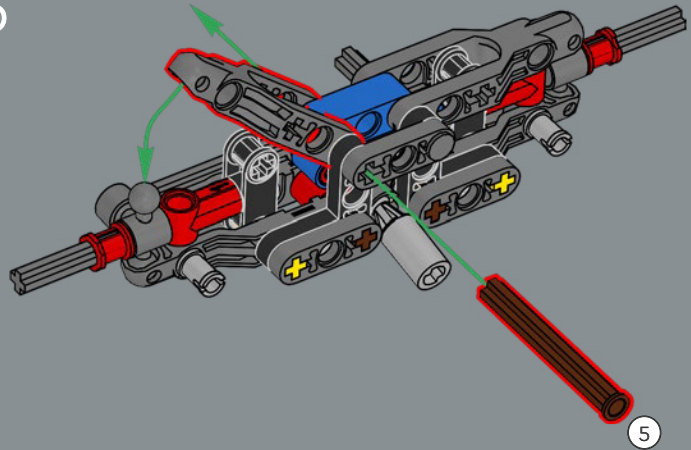

406

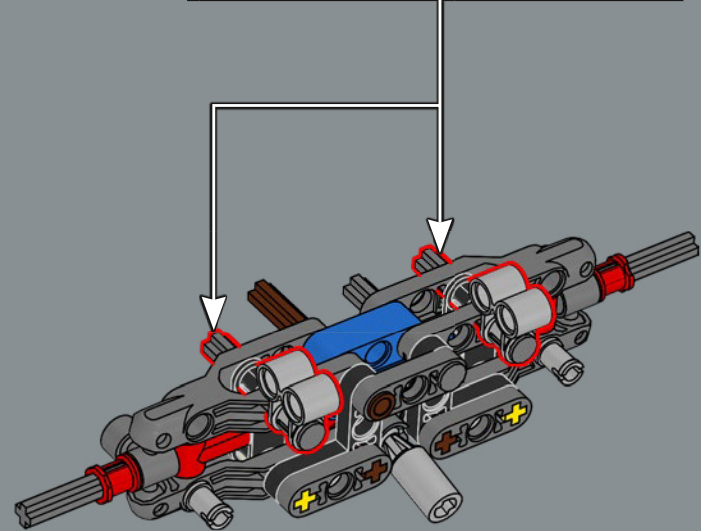
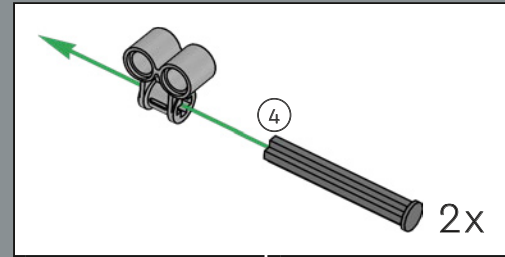



407

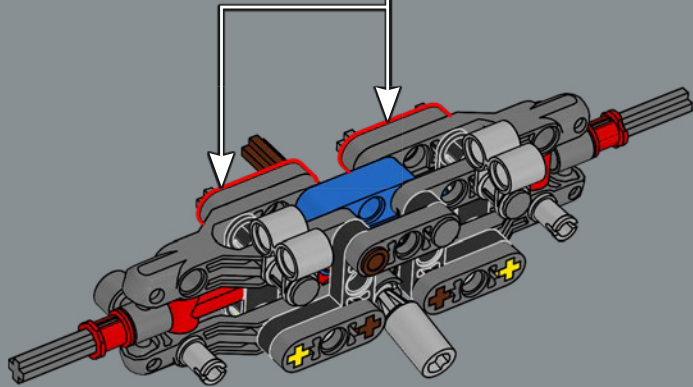
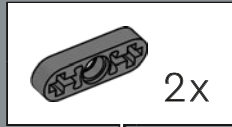

408

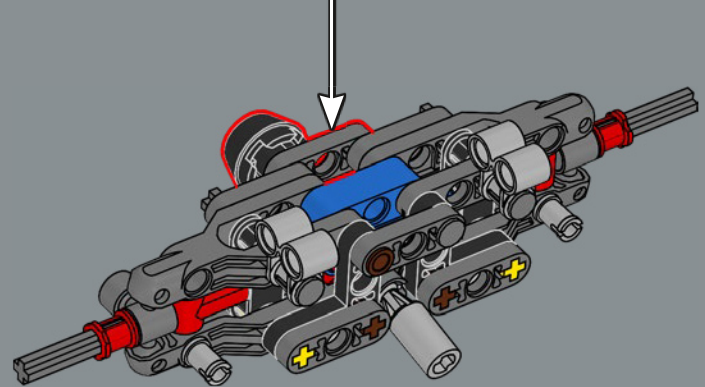
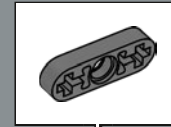

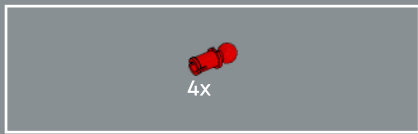

409

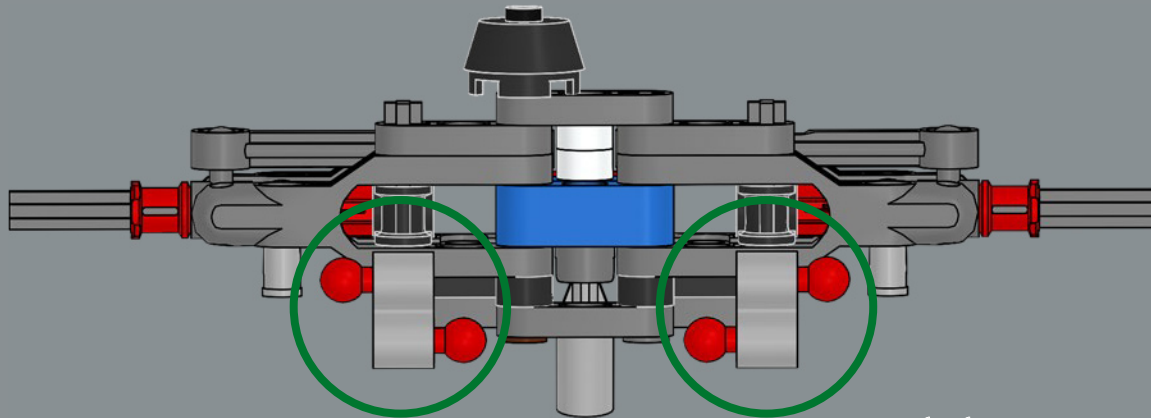
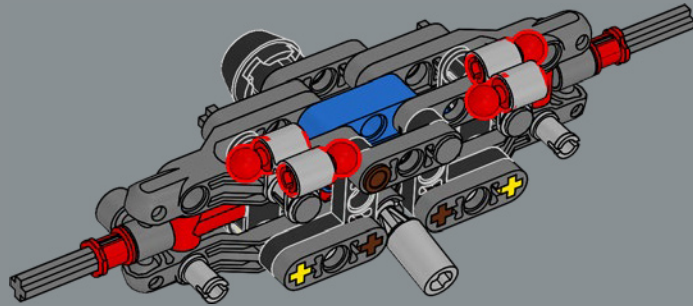

1:1

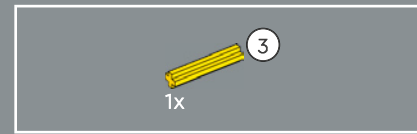

410

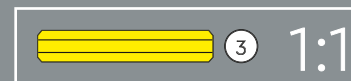
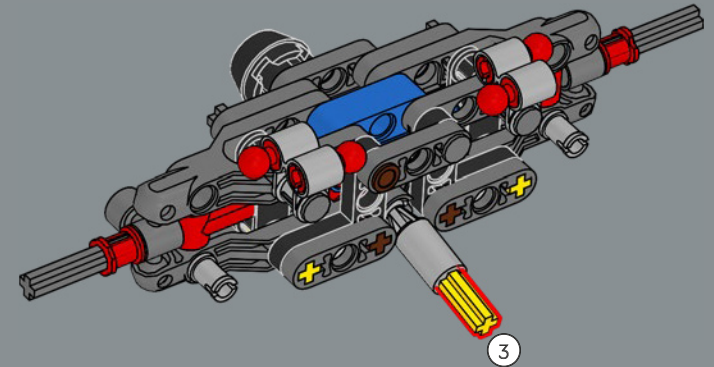

411

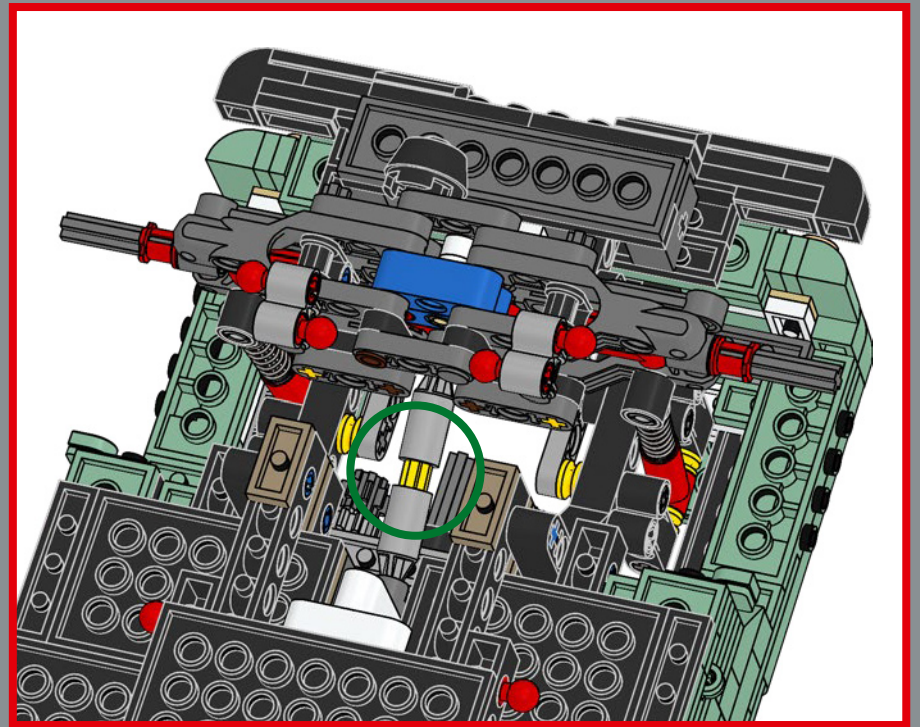
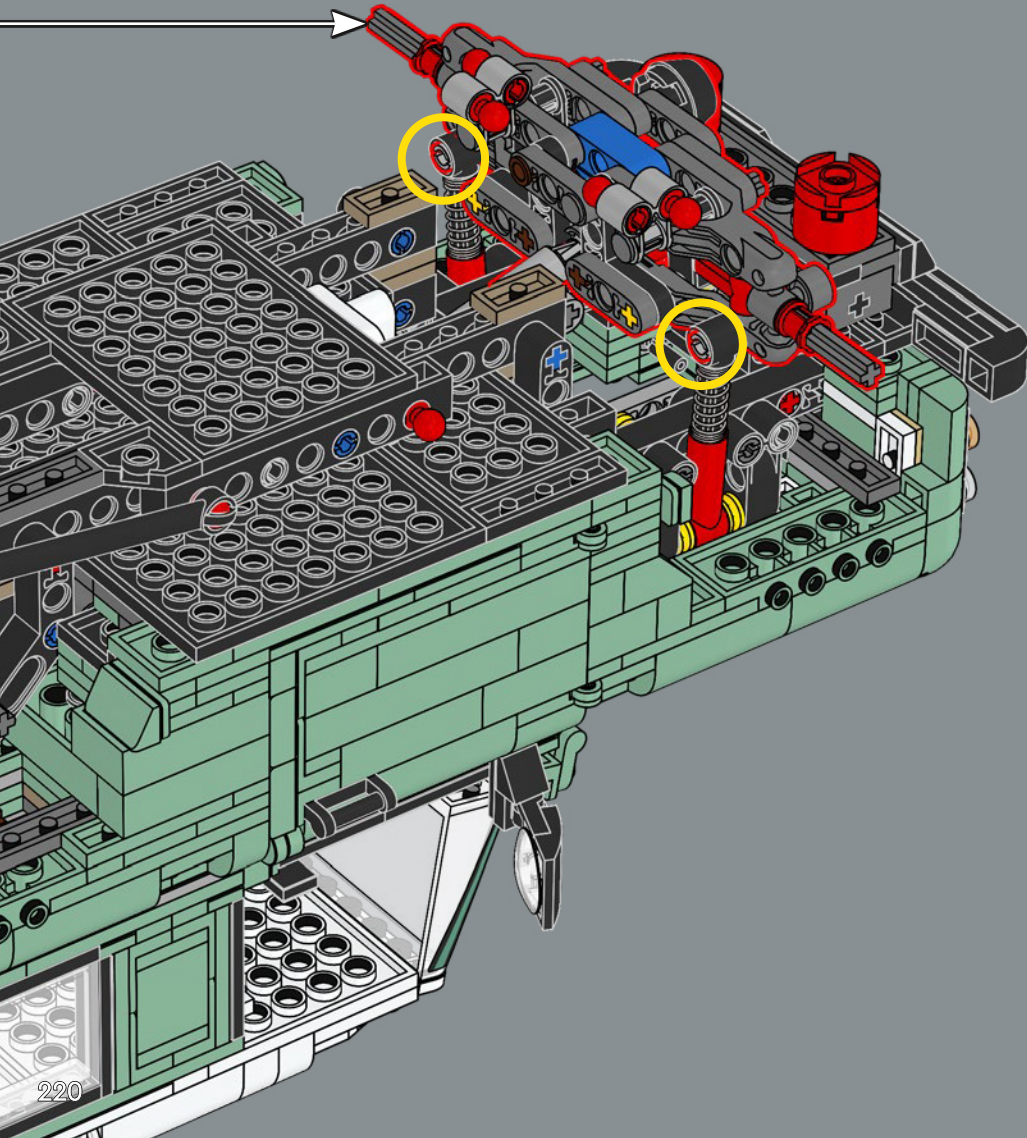

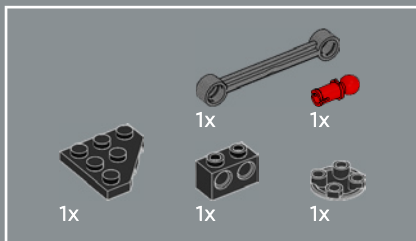

412

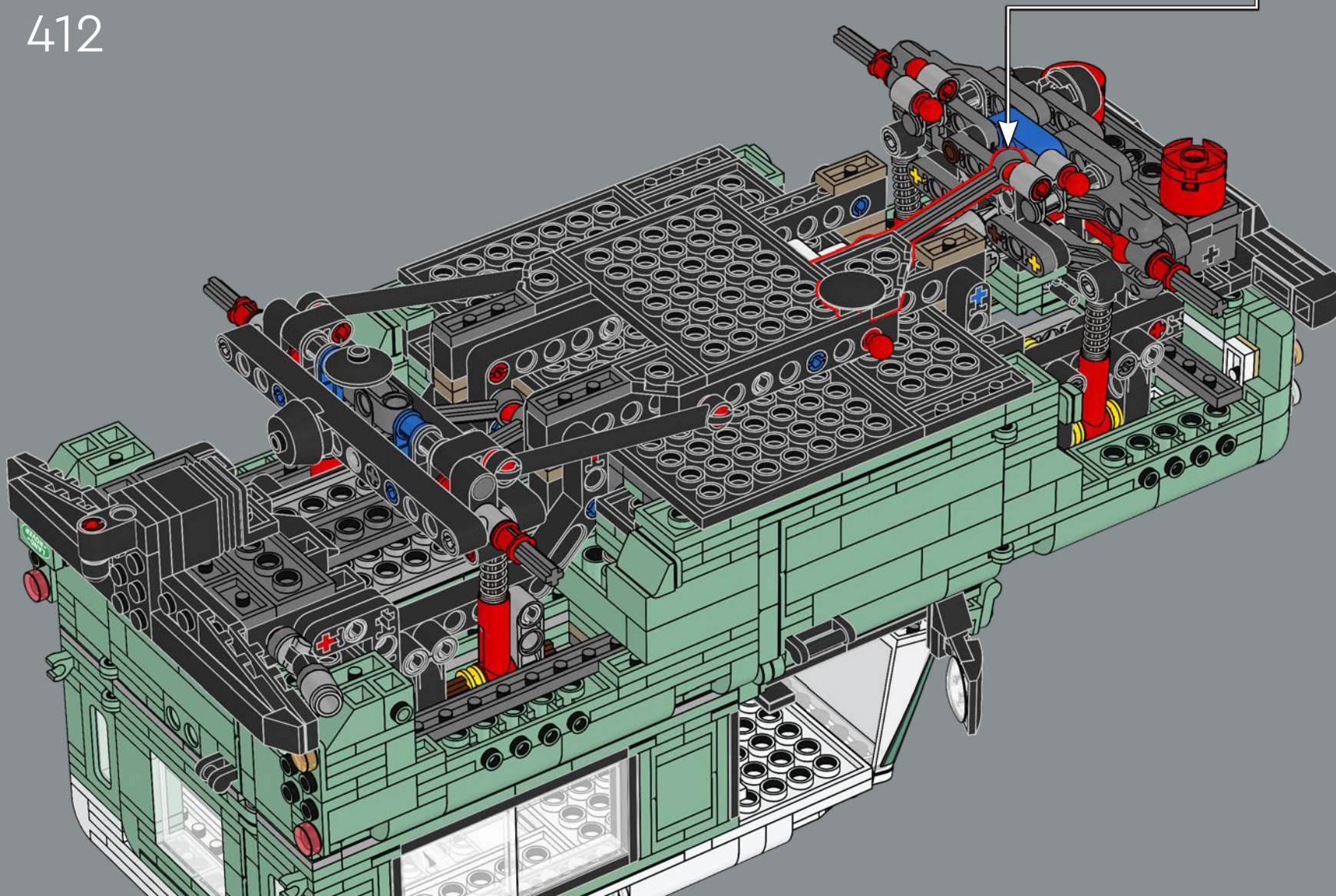
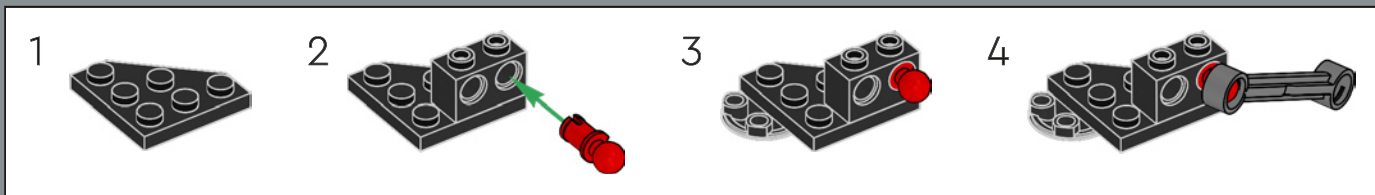

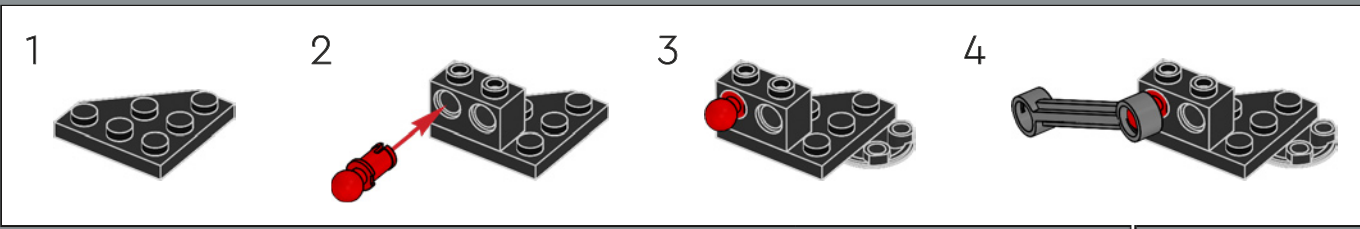
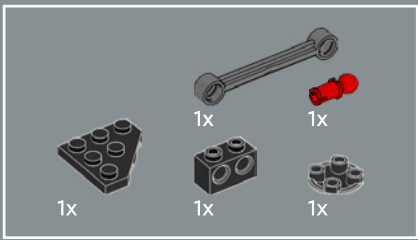

413

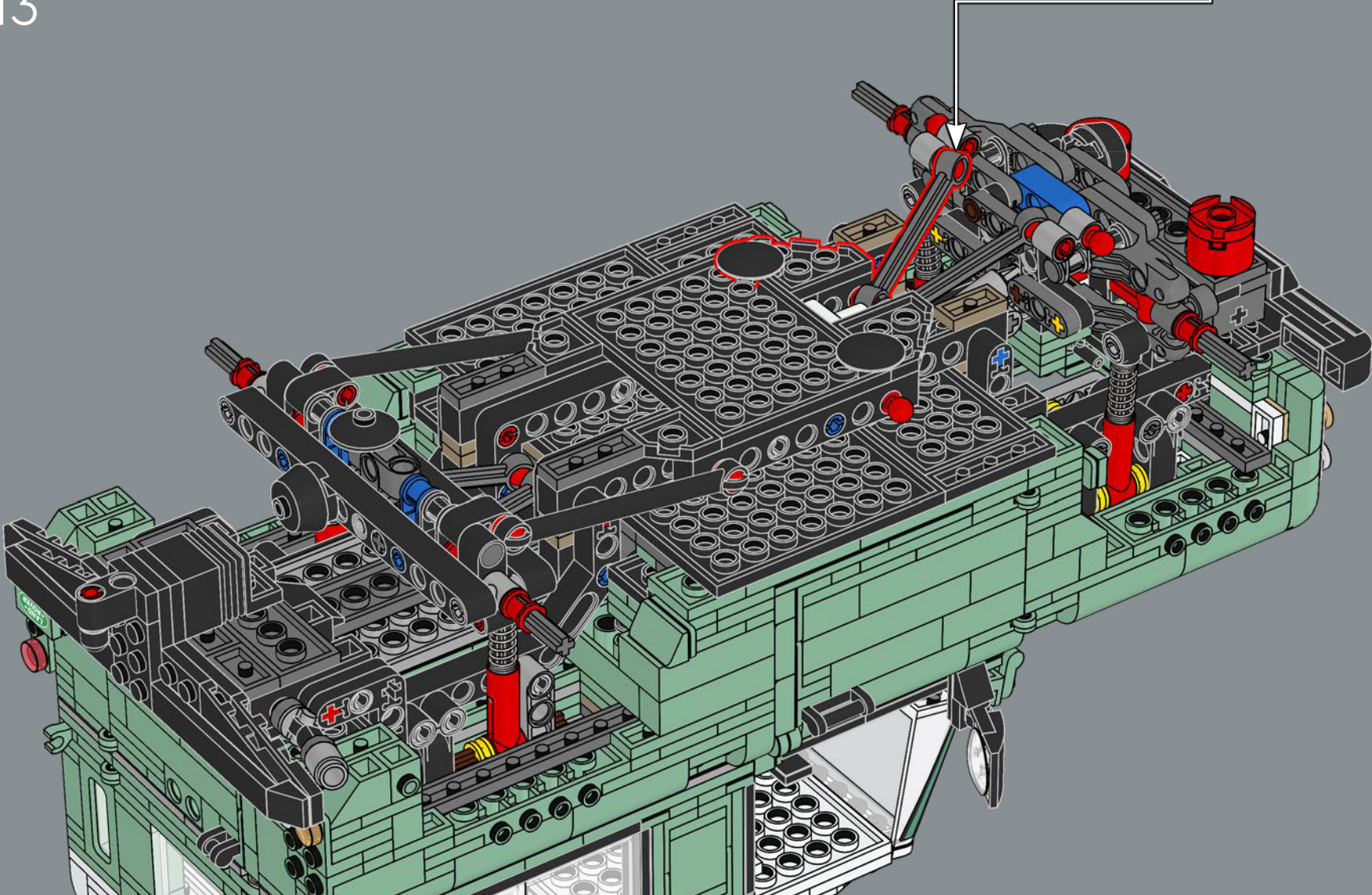

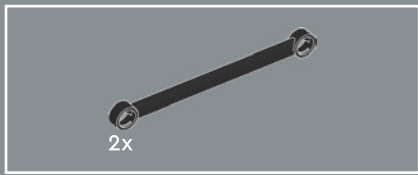

414

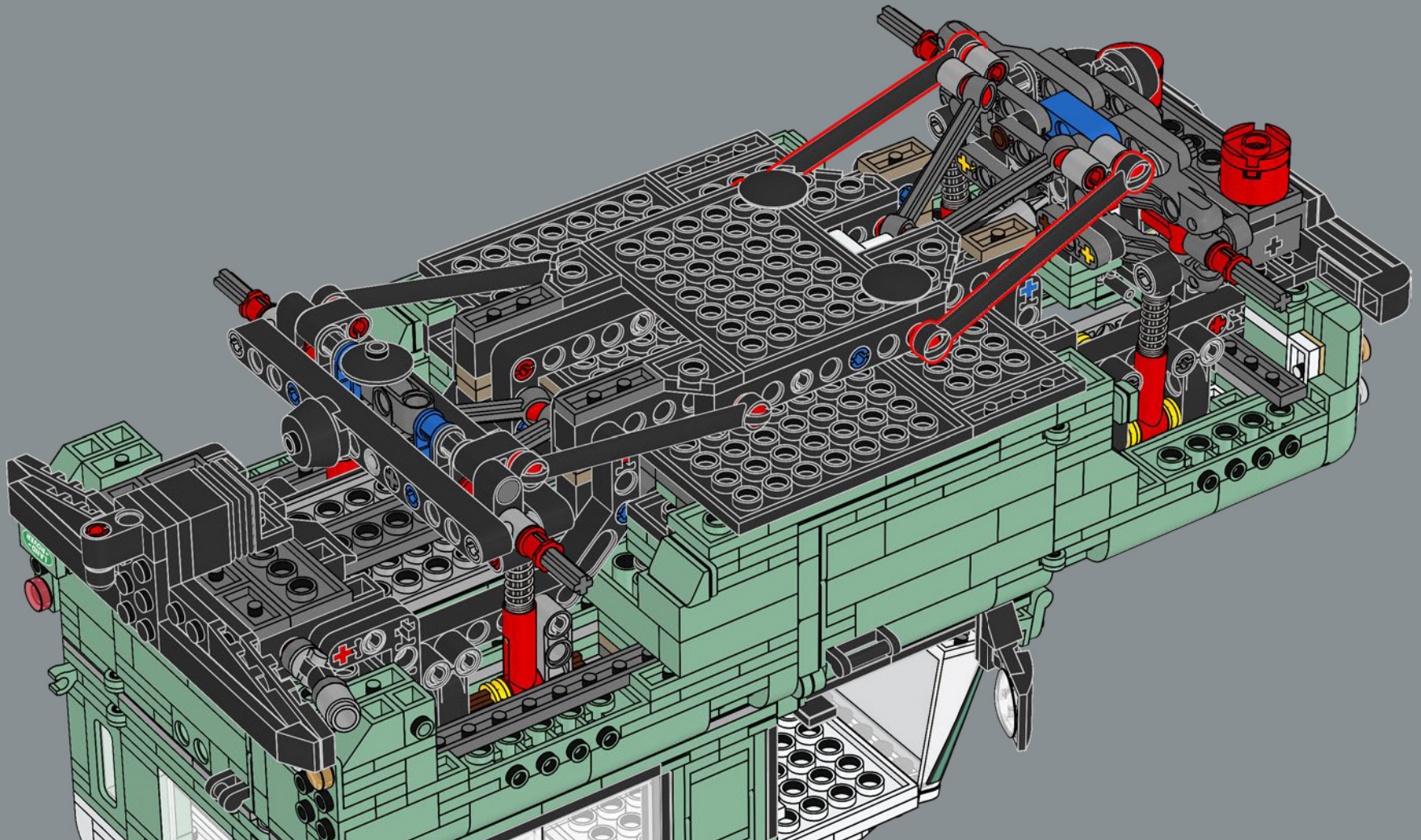

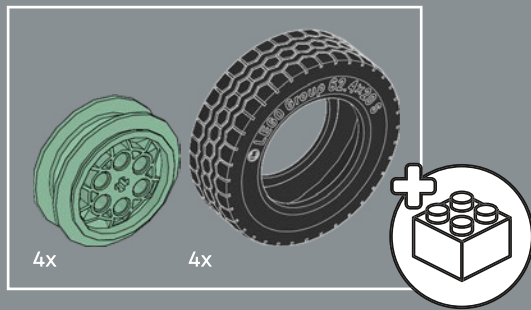

415

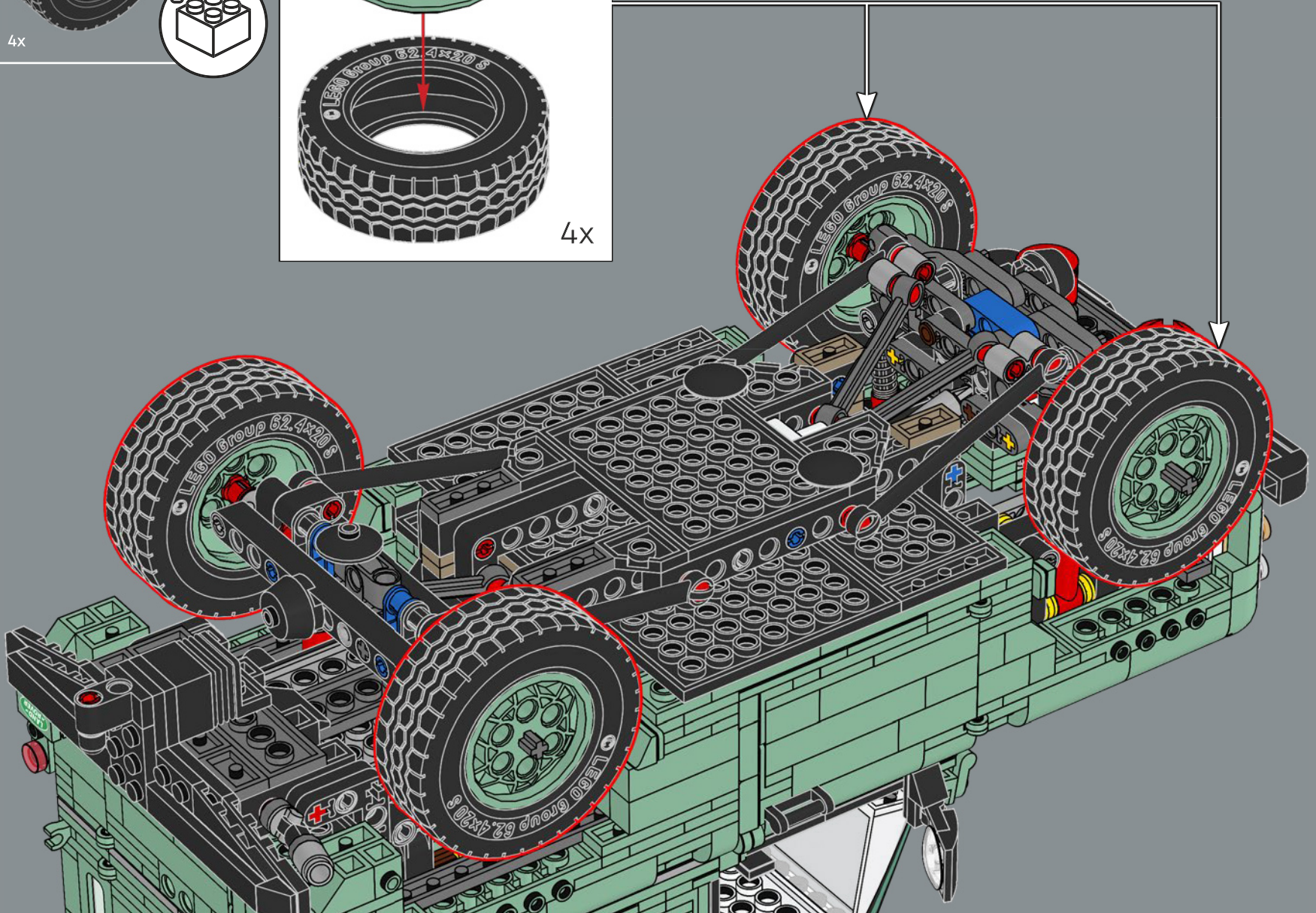
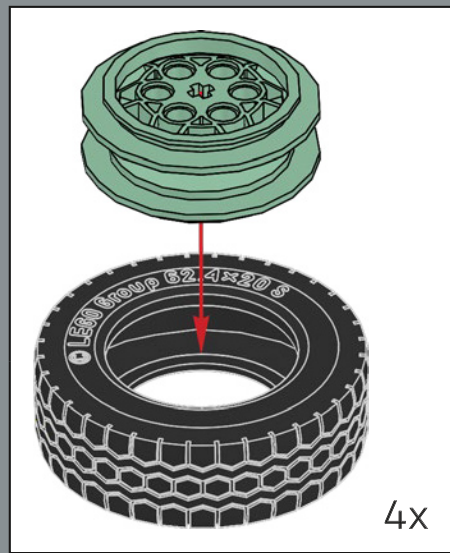



4x

The 'classic Defender 90' model name represents the wheelbase of 90 inches (228 centimeters).

Le nom du modèle « Defender 90 classique » fait référence à l'empattement de 90 pouces (228 centimètres).

El nombre de modelo "Defender 90 clásico" hace referencia a la distancia entre ejes de 90 in (228 cm) del vehículo.



4x

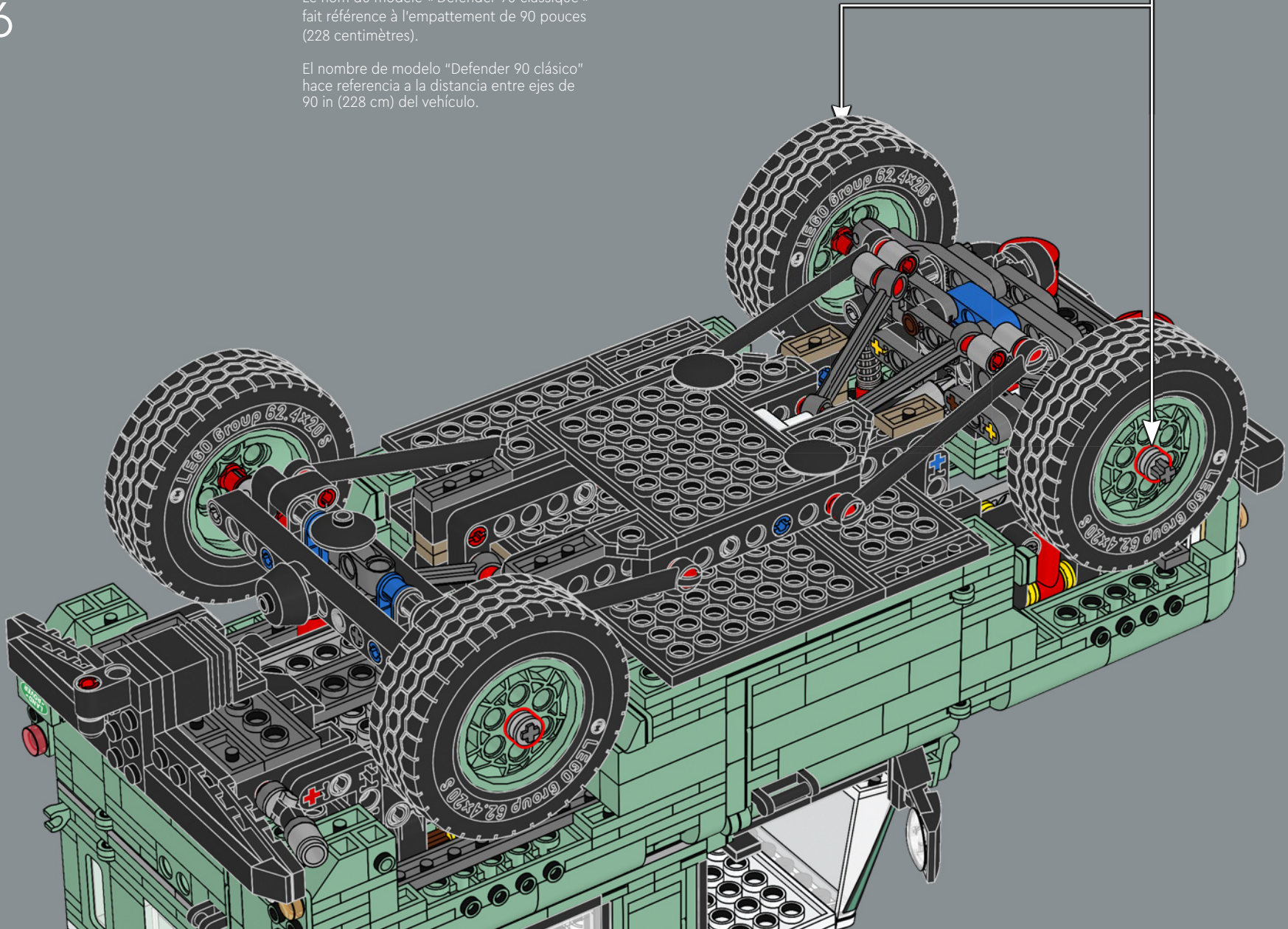

417

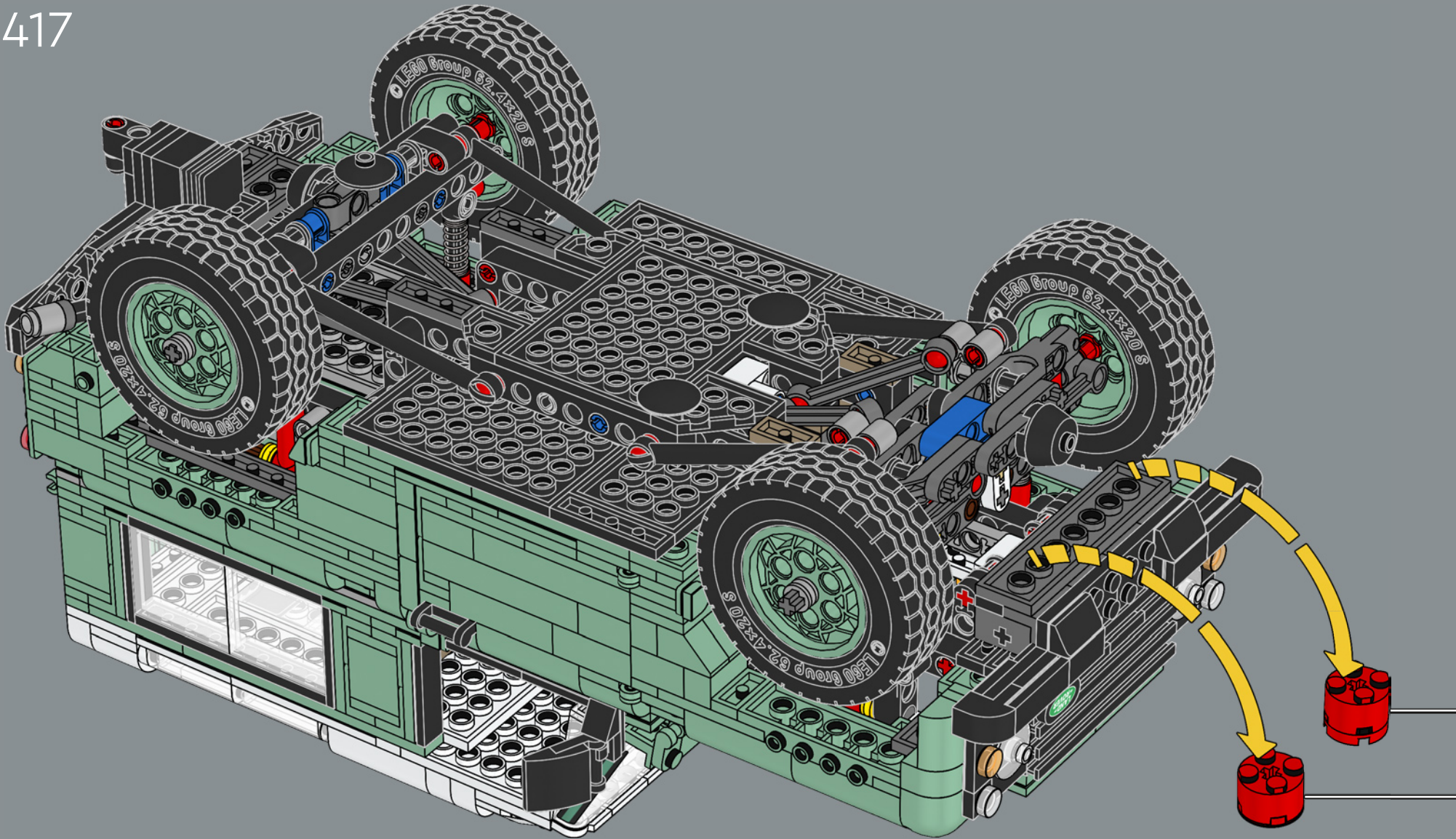



418

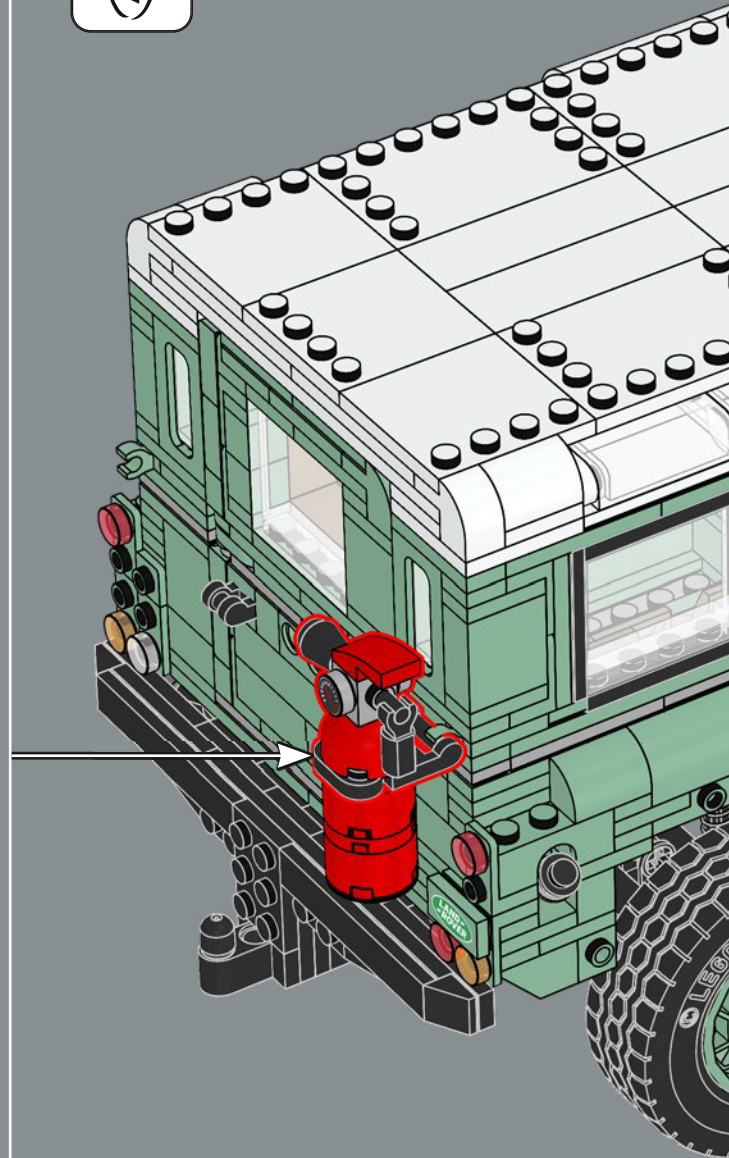
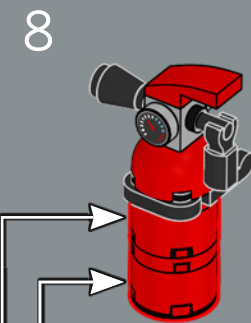
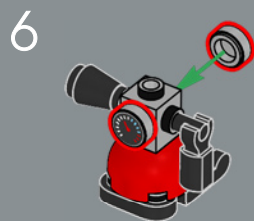
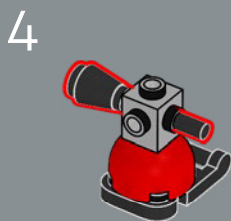
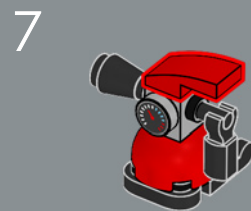
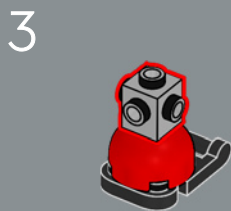
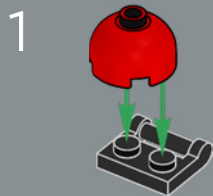

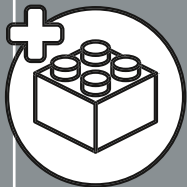
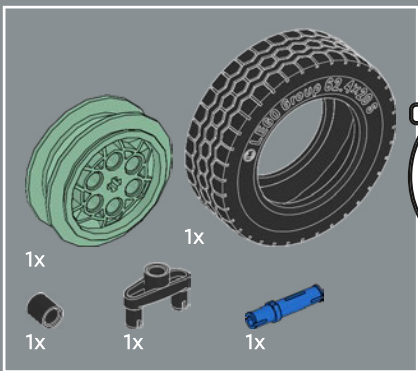

419

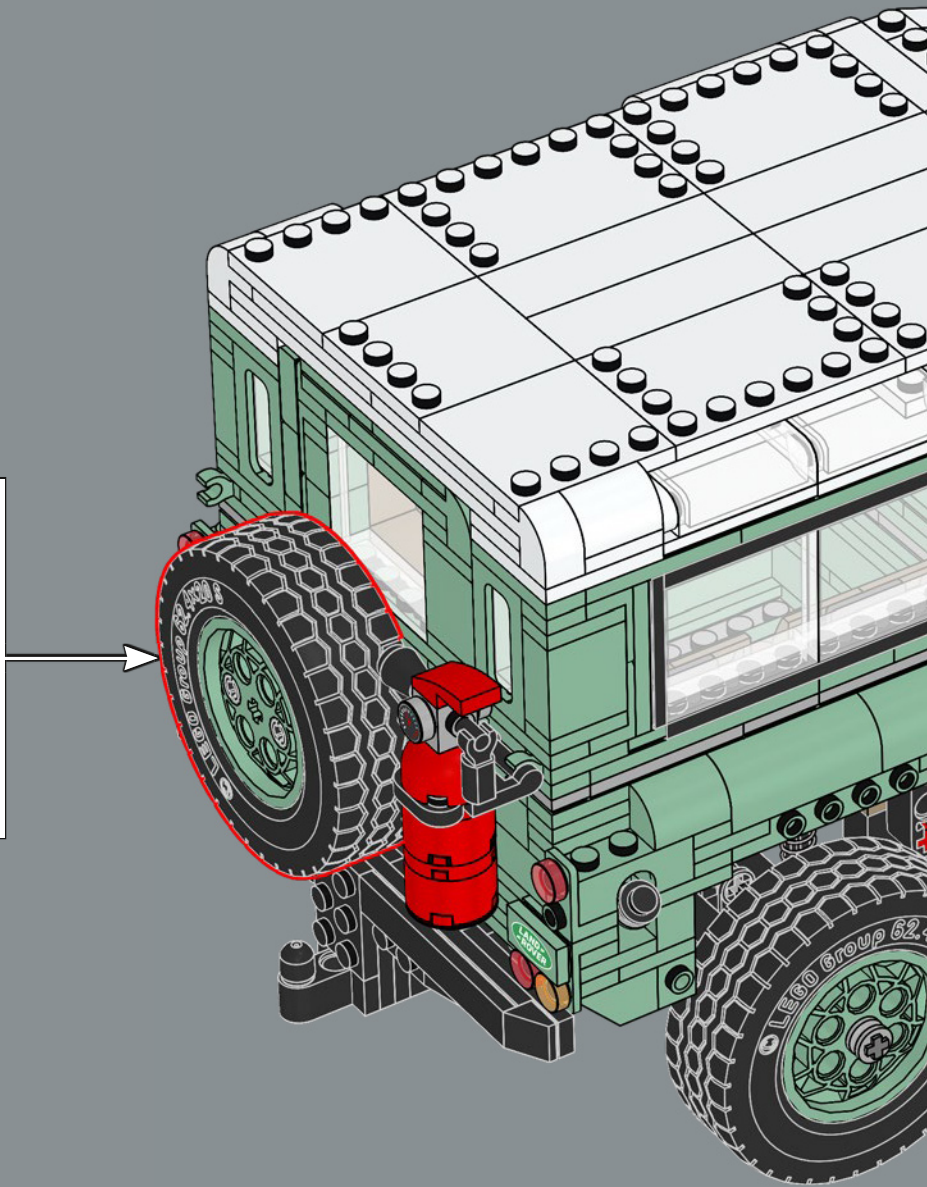
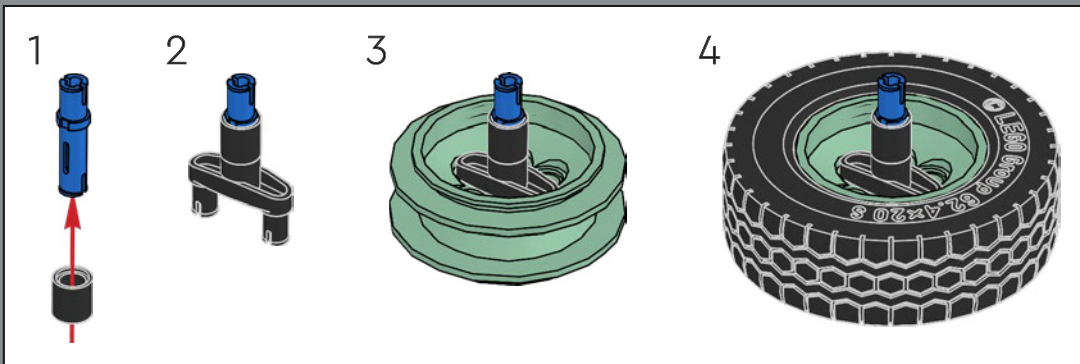



420

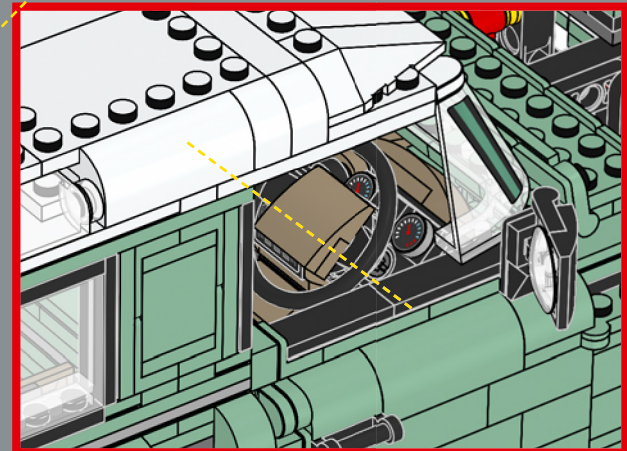
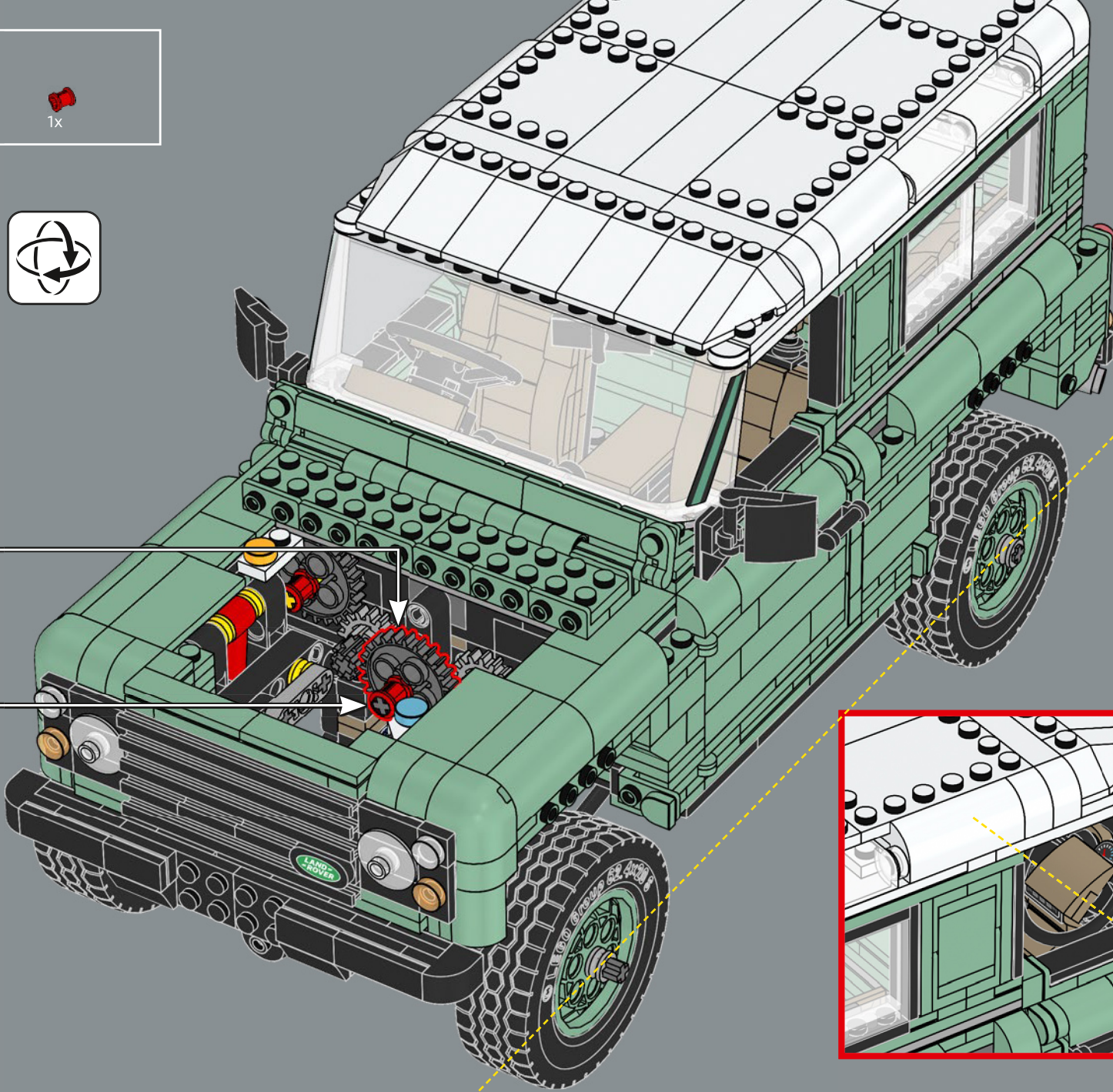
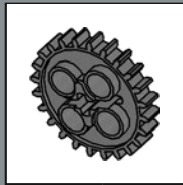

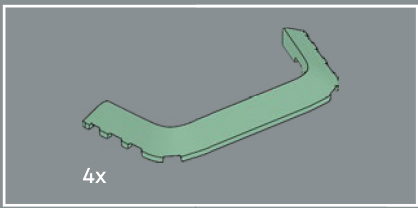

421

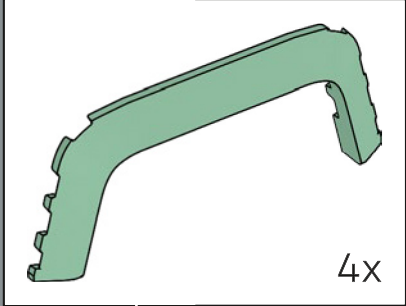

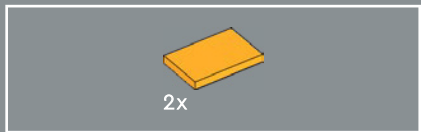

422

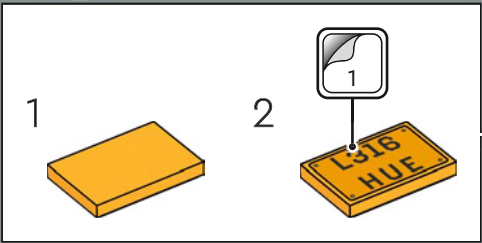
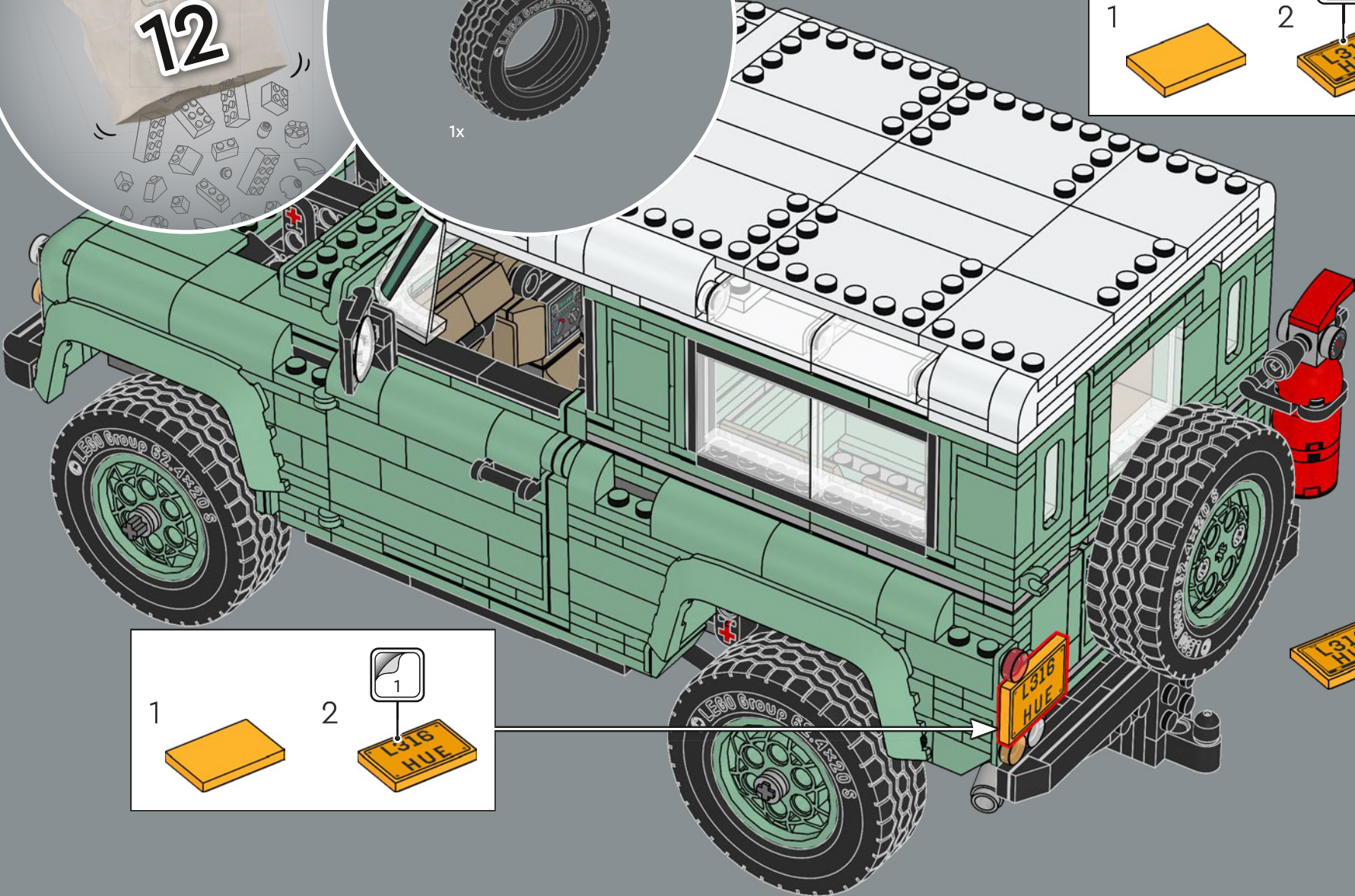
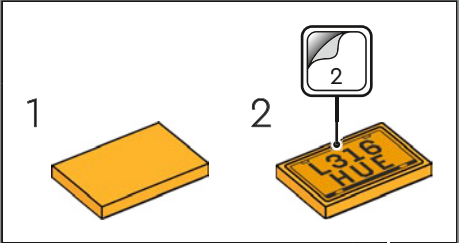

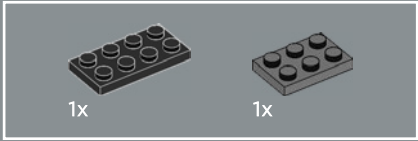
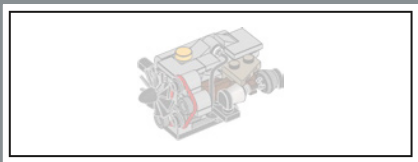

423

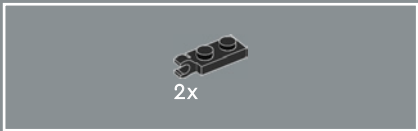
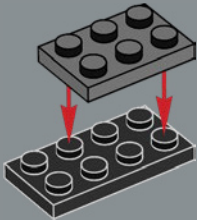

424

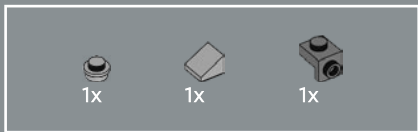
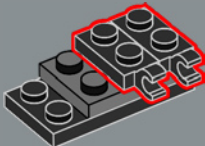

425

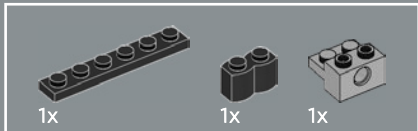
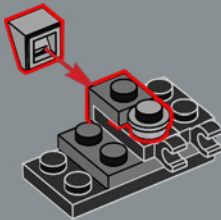

426

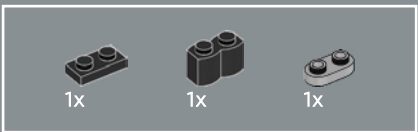
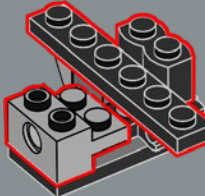

427

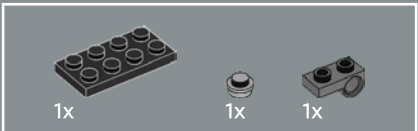
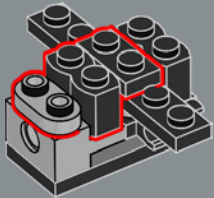

428

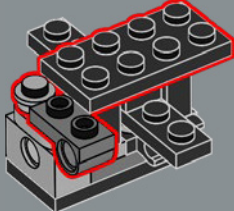

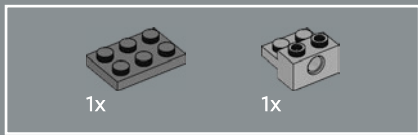

429

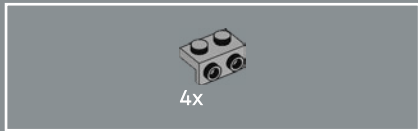
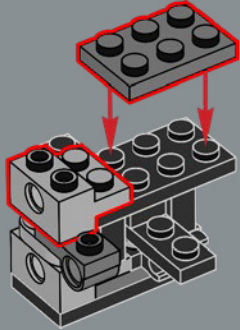

430

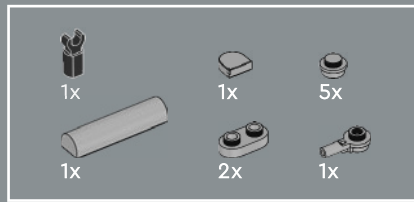
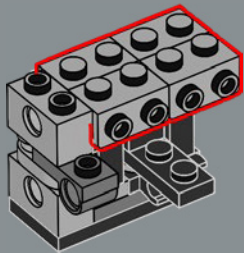

431

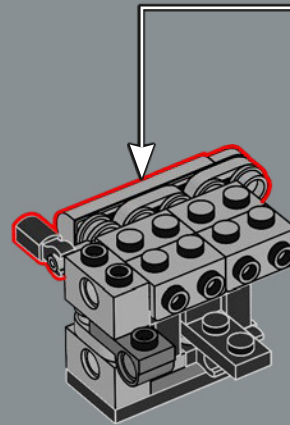
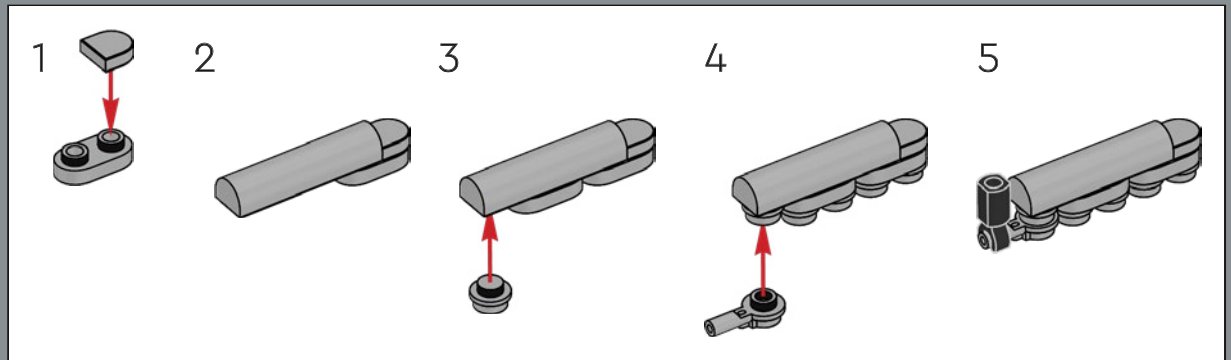



432

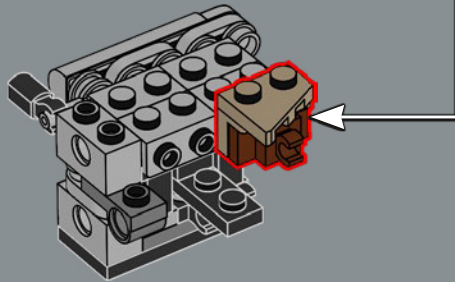
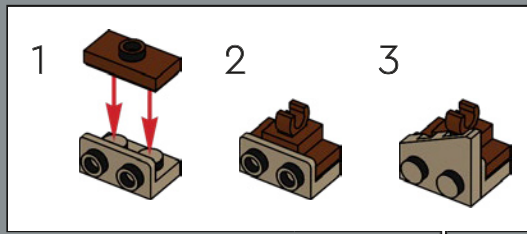

433

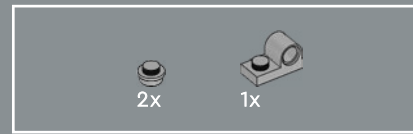
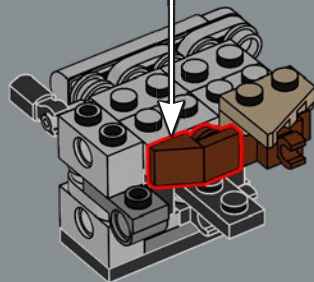
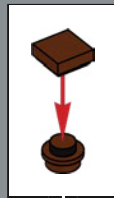

434

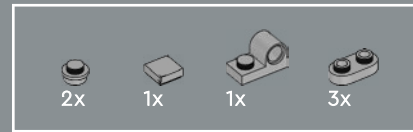
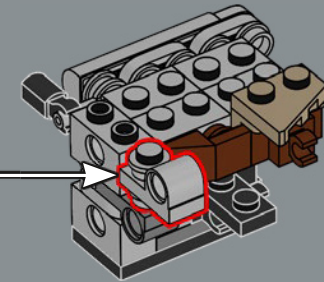
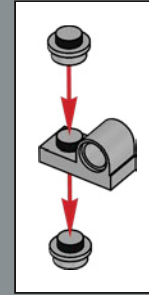

435

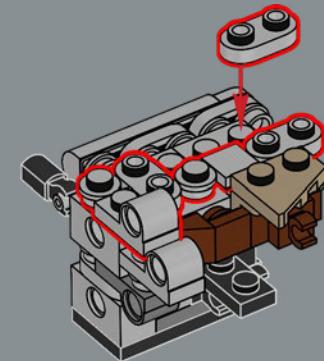

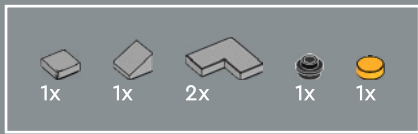

436

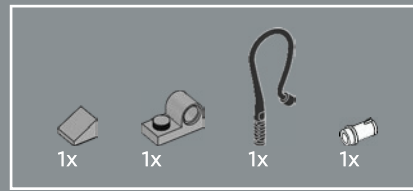
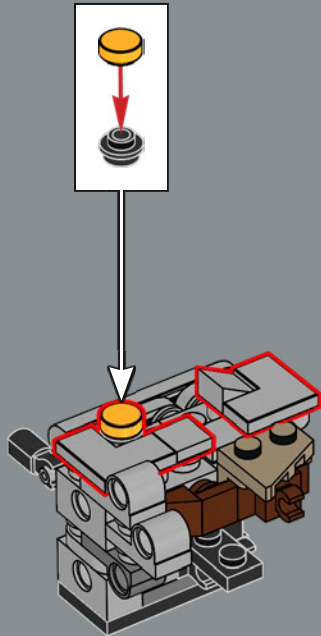

437

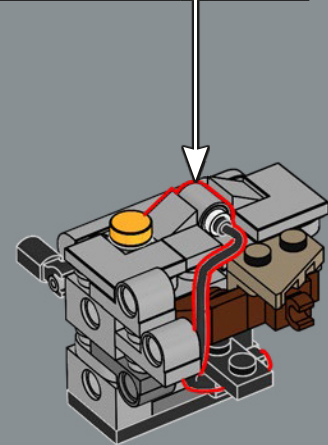
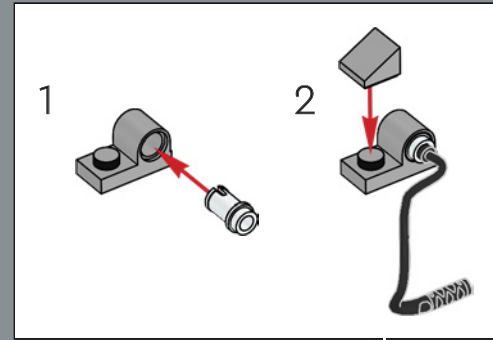



438

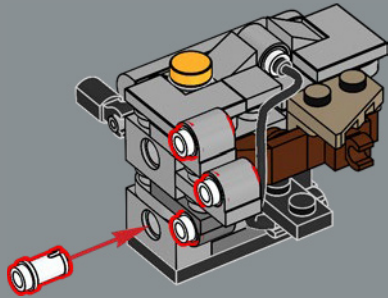

439

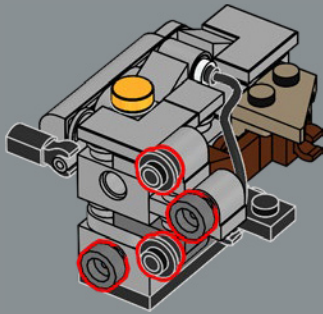

440

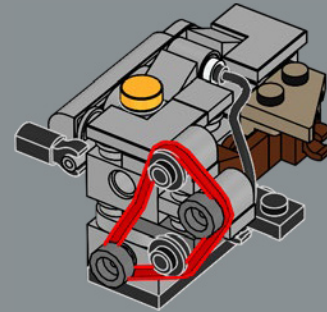



441

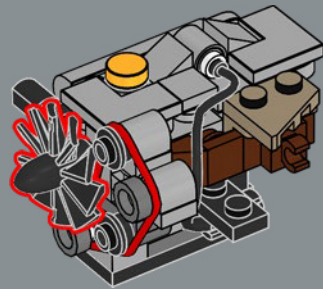

Both LEGO® engines replicate authentic details from the real-life engines.

Les deux moteurs LEGO® reproduisent les détails authentiques des moteurs réels.

Ambos motores LEGO® replican detalles auténticos de los motores de la vida real.

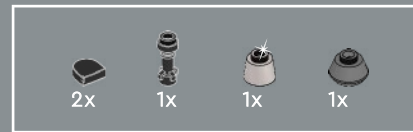

442

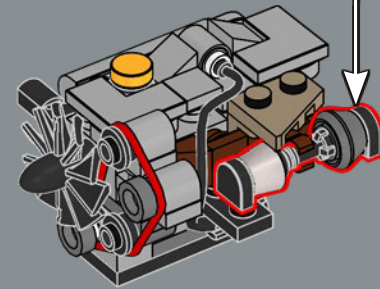

443

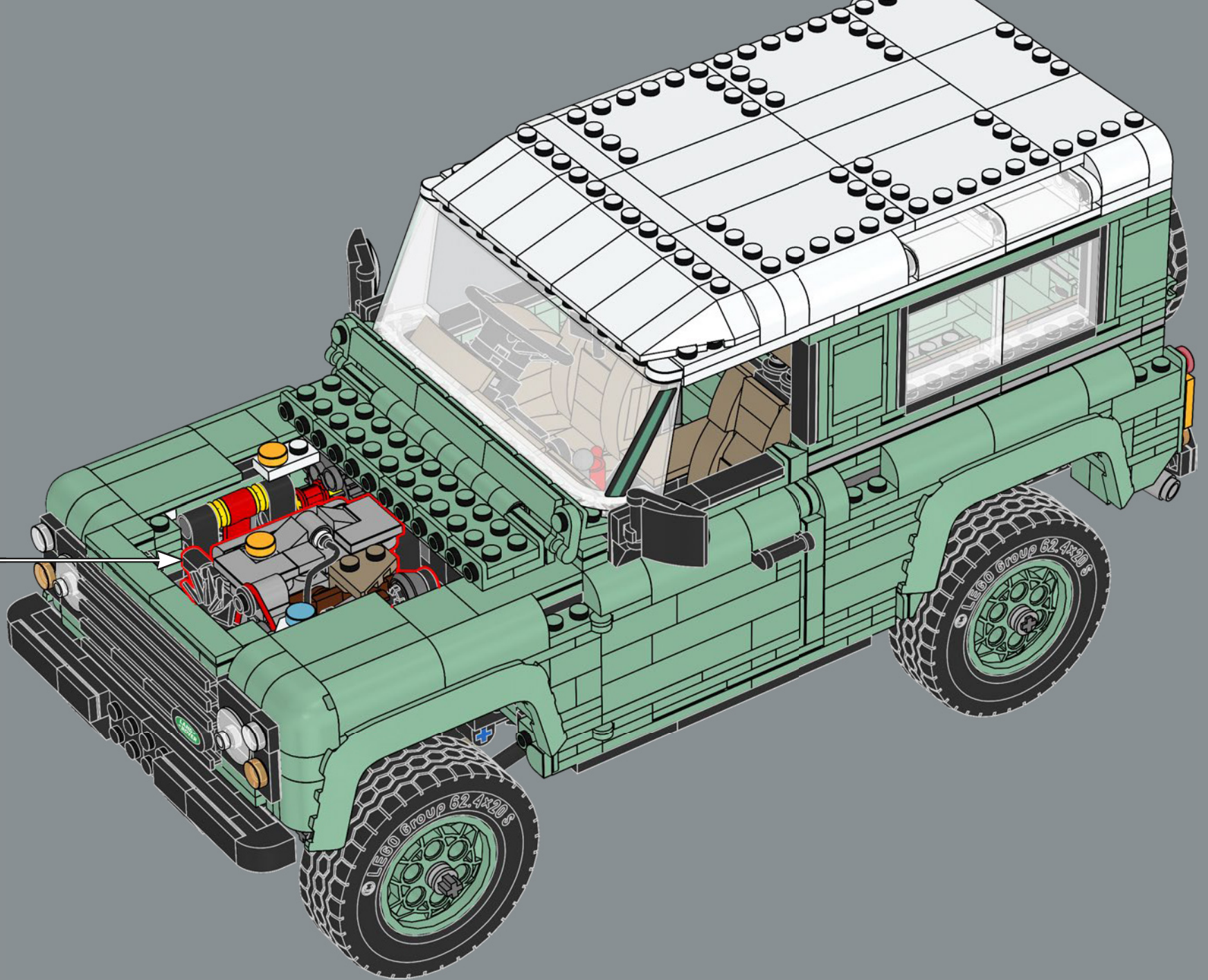

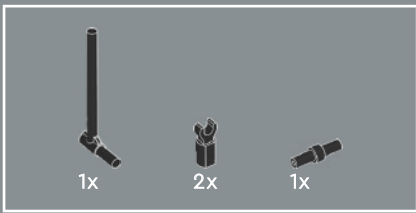

444

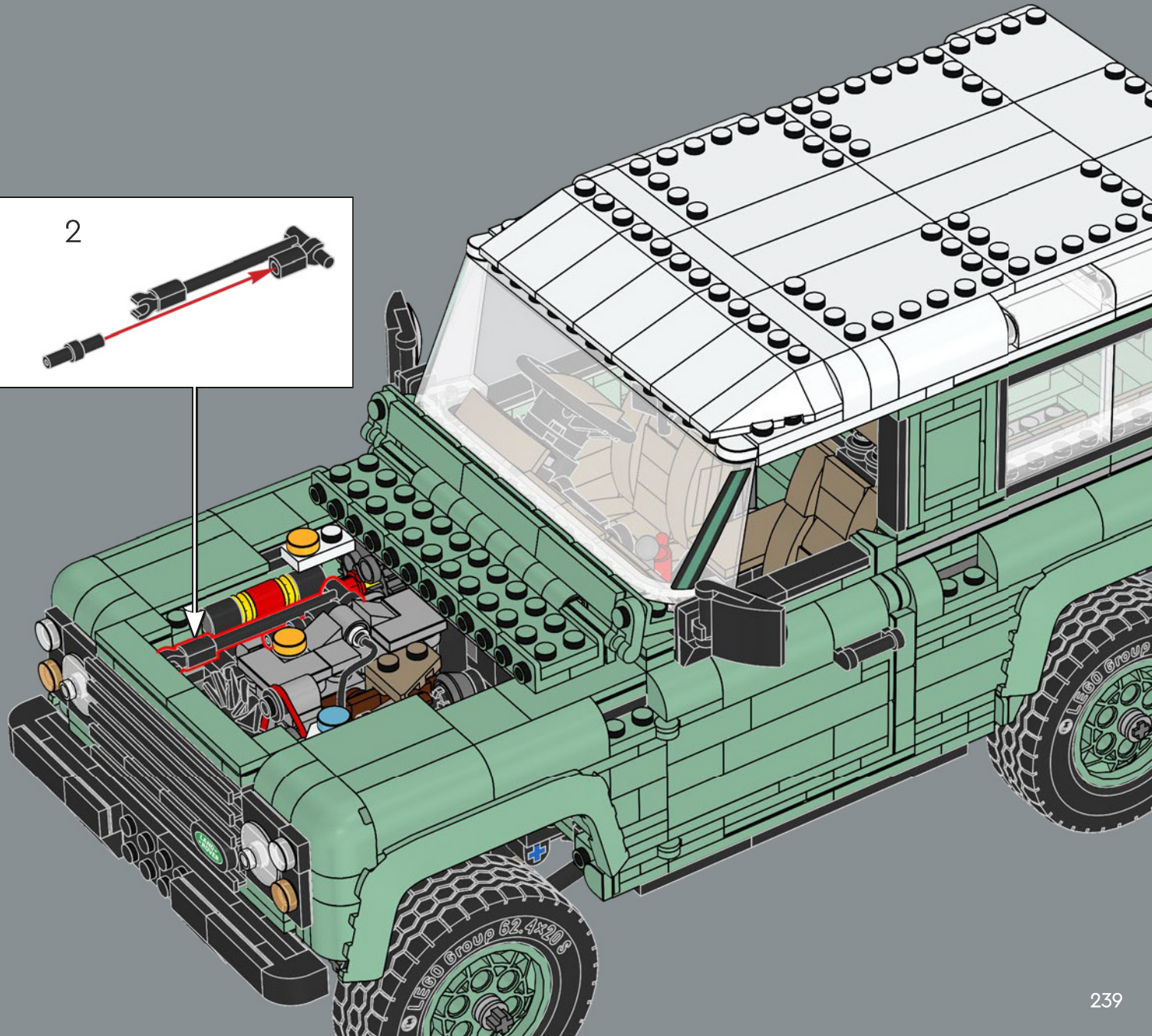
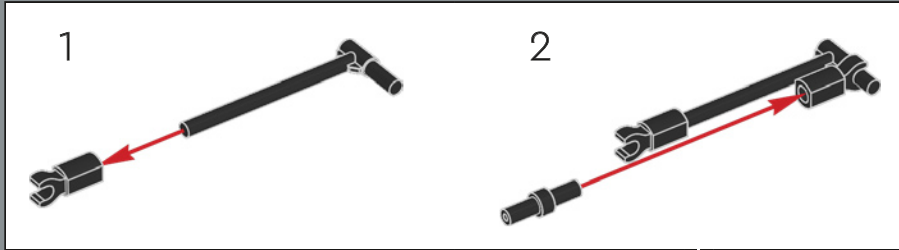

CUSTOMIZE FOR YOUR DEMANDS PERSONNALISEZ EN FONCTION DE VOS ENVIES PERSONALÍZALO SEGÚN TUS NECESIDADES

EXPEDITION MODEL

Build and add a range of all-terrain, multi-purpose accessories to your model for your dream off-road adventures.

Go to page [242](#).



MODÈLE D'EXPÉDITION

Construisez et ajoutez une gamme d'accessoires tout-terrain et polyvalents à votre modèle pour vivre les aventures tout-terrain de vos rêves.

Aller à la page [242](#).

MODELO EXPEDITION

Construye tu modelo y equípalo con accesorios multipropósito para vivir la aventura de tus sueños fuera de todos los caminos conocidos.

Ve a la página [242](#).

Turbo Diesel Engine

The five-cylinder, turbo diesel engine is built for rough terrain performance.

Moteur turbodiesel

Le moteur turbo diesel à cinq cylindres est conçu pour une performance optimale en terrain accidenté.

Motor turbodiesel

El motor turbodiesel de cinco cilindros está hecho para ayudarte a superar los terrenos más difíciles.

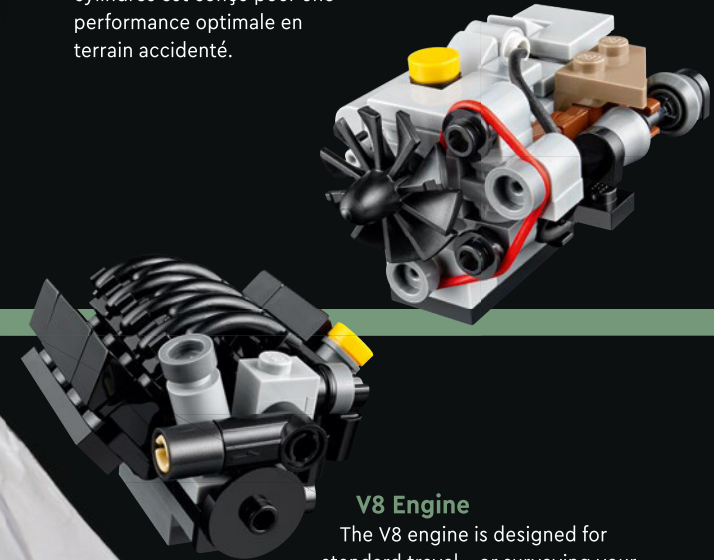

V8 Engine

The V8 engine is designed for standard travel – or surveying your estate.

Moteur V8

Le moteur V8 est conçu pour les déplacements standards – ou pour arpenter votre domaine.

Motor V8

El motor V8 está diseñado para viajes normales o recorridos de supervisión de tu propiedad rural.



'BULGE' VERSION 'A'

The front hood bulge makes room for the turbo diesel engine.
See page [292](#).

CAPOT BOMBÉ – VERSION A

Le bombage du capot avant permet d'accueillir le moteur turbo diesel. Aller à la page [292](#).

VERSIÓN A: "ABULTADO"

La prominencia del cofre se añadió para dar cabida al motor turbodiésel. Consulta la página [292](#).

'SLEEK' VERSION 'B'

The sleek hood makes for another standout display model.
See page [300](#).

CAPOT LISSE – VERSION B

Le capot lisse en fait un autre modèle d'exposition remarquable. Aller à la page [300](#).

VERSIÓN B: "LIMPIO"

El cofre liso hace que el modelo de exhibición se vea espectacular. Consulta la página [300](#).



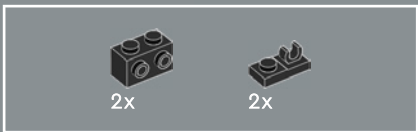

445

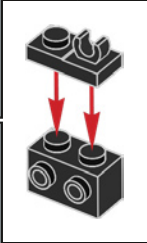
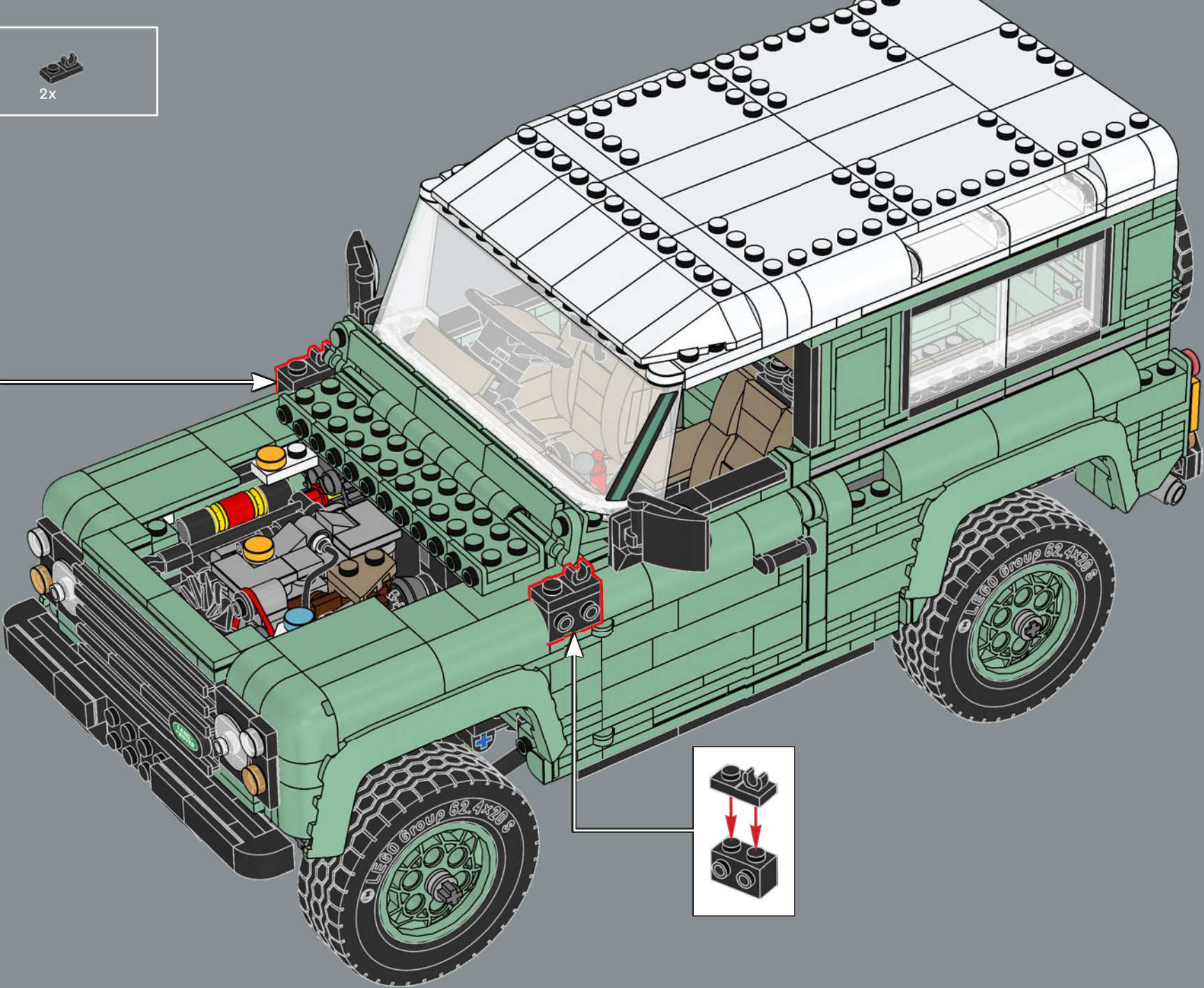
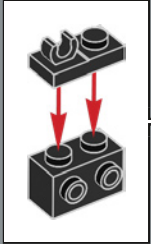



446

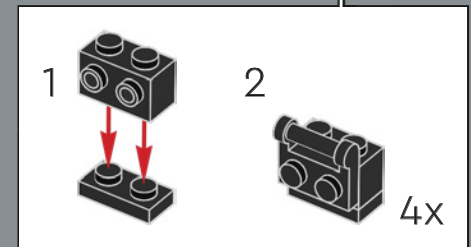
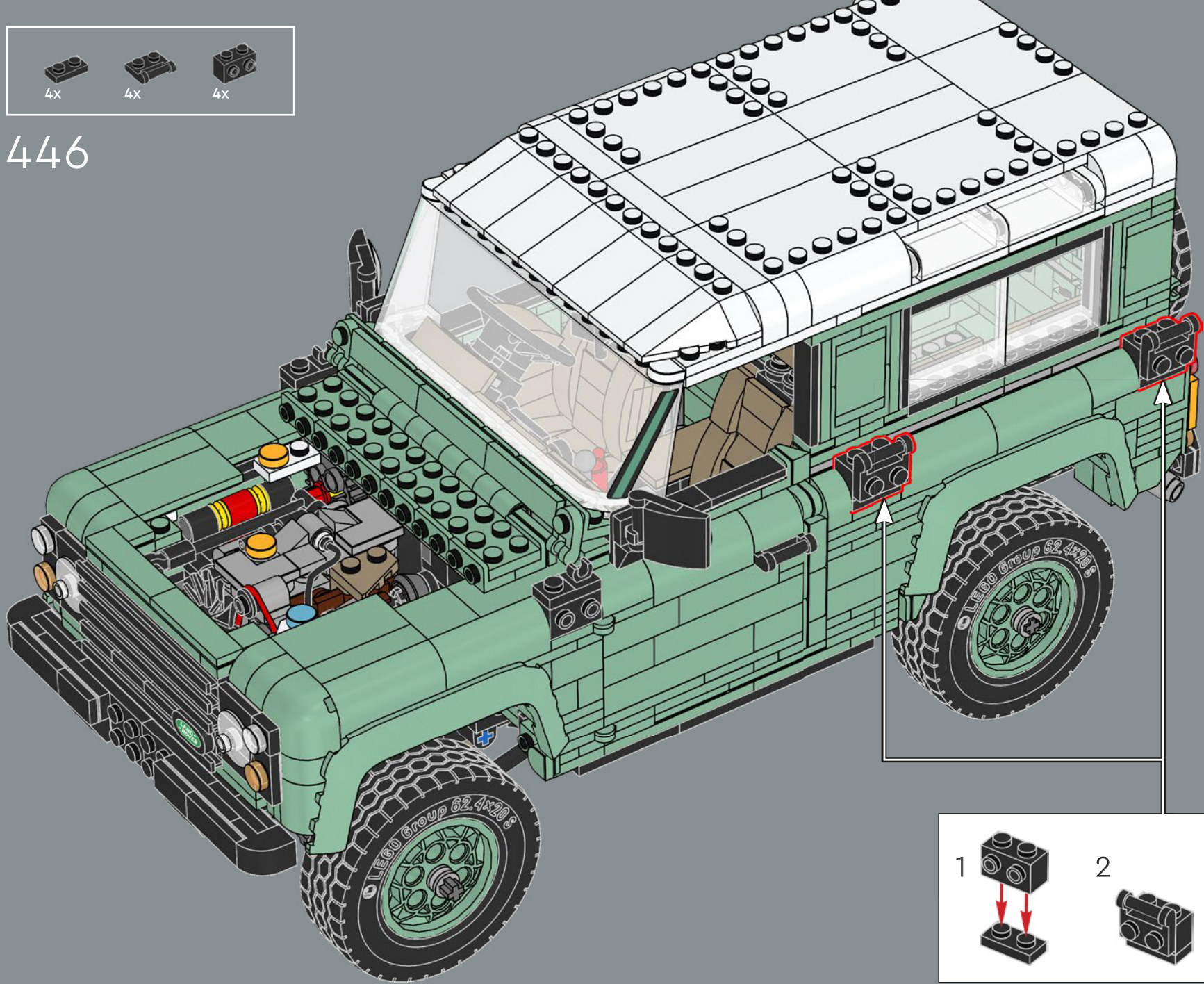

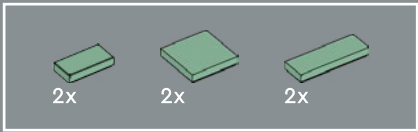

447

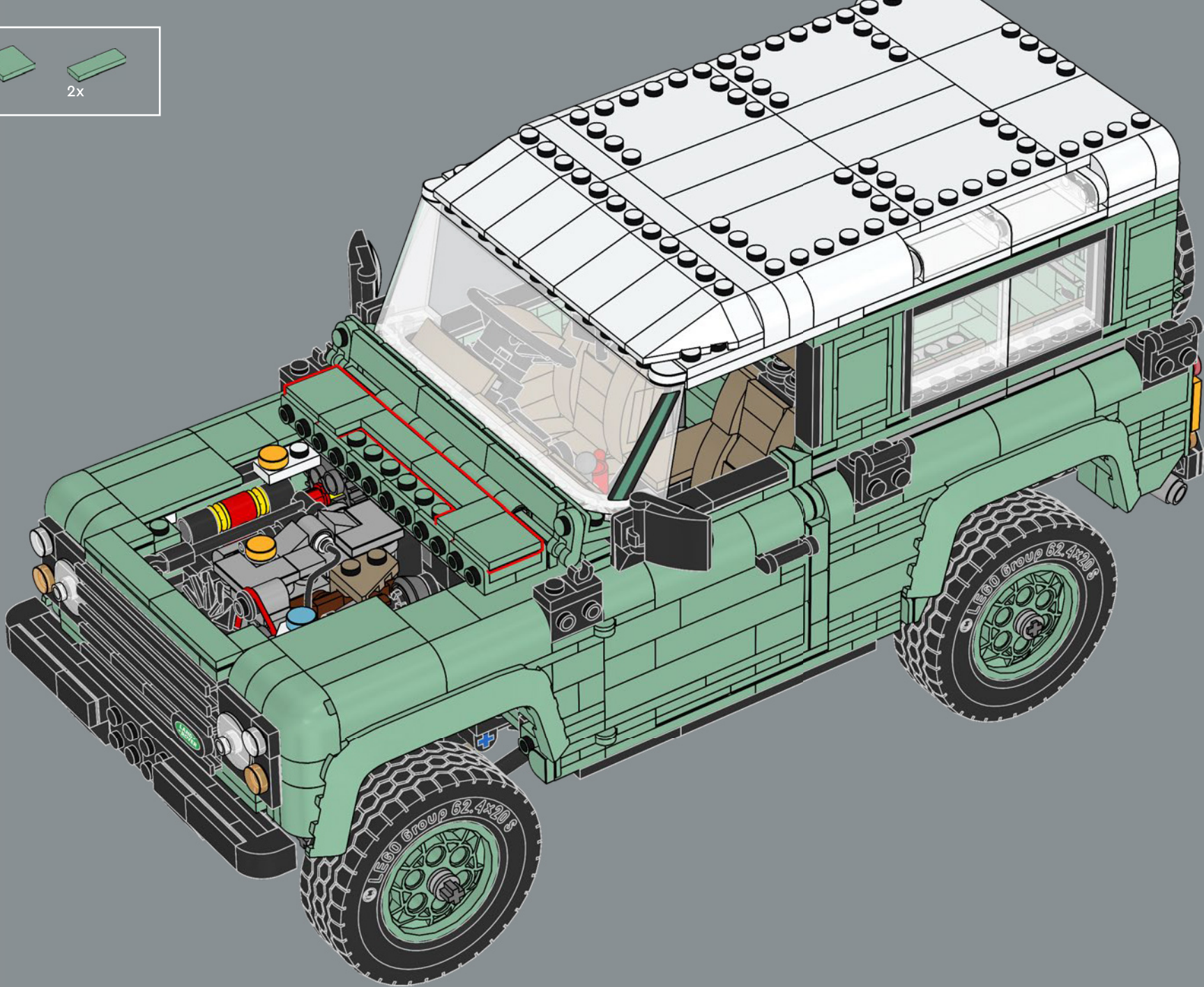

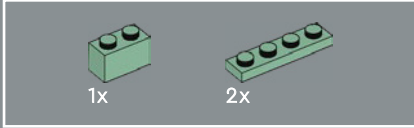
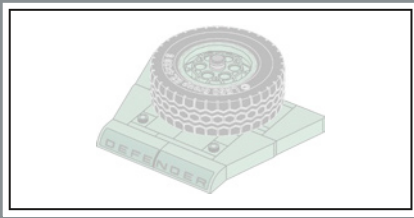

448

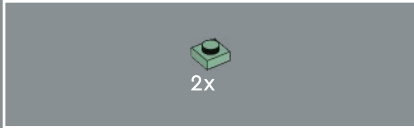
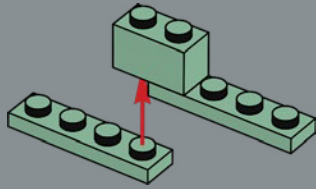

449

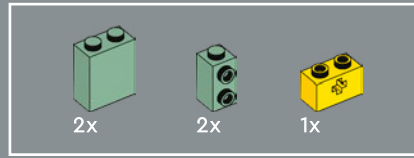
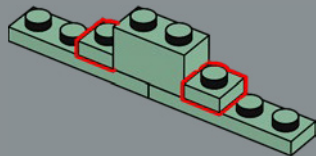

450

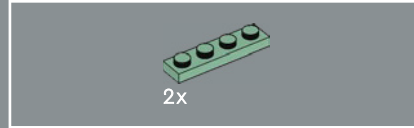
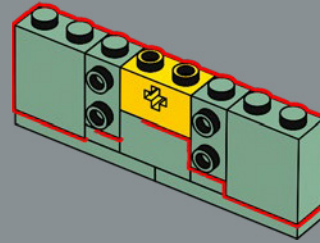

451

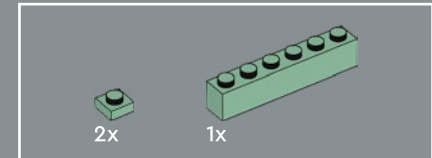
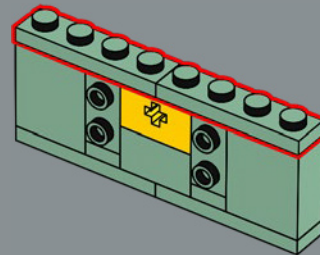

452

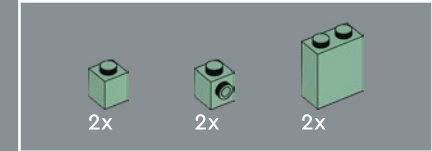
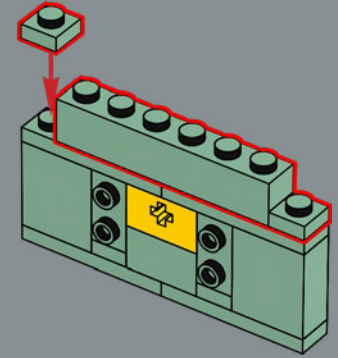

453

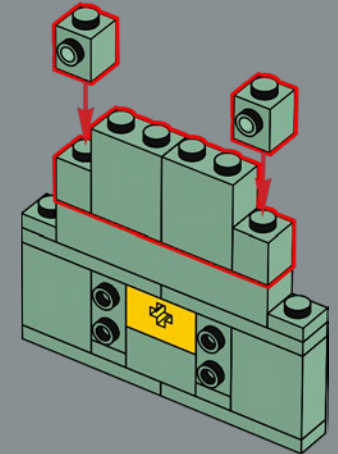

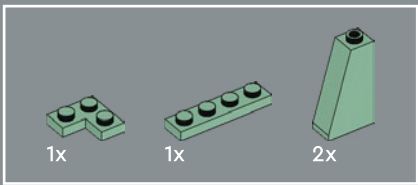

454

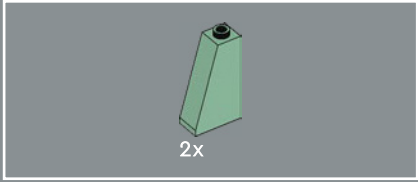
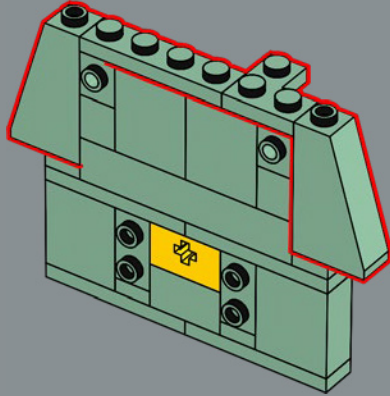

455

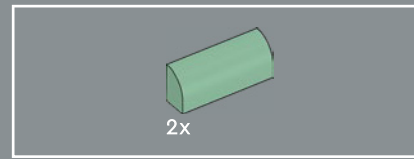
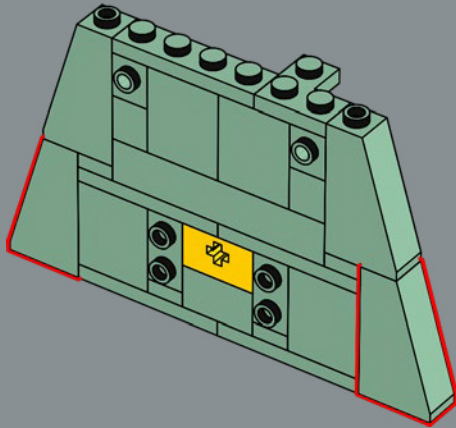

456

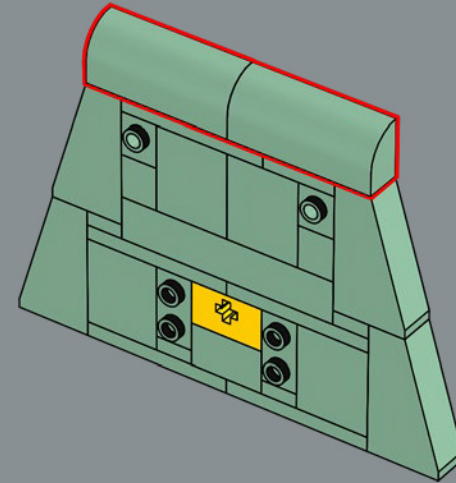

457

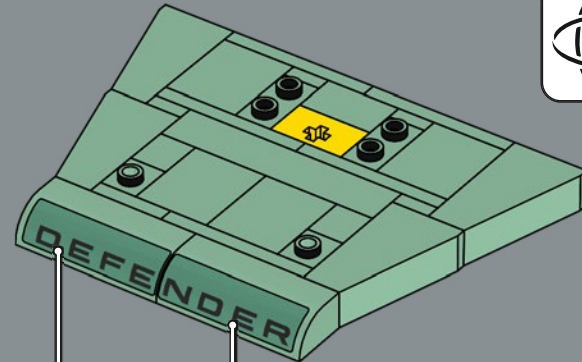

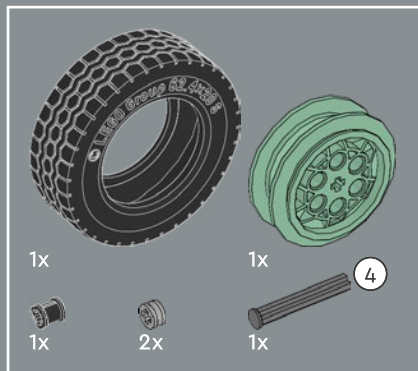

458

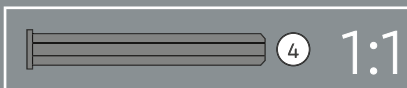
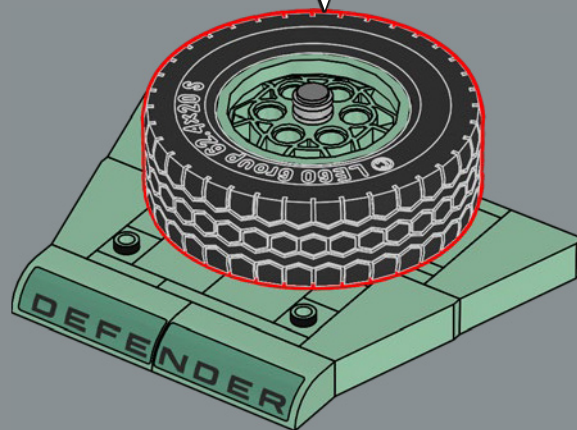
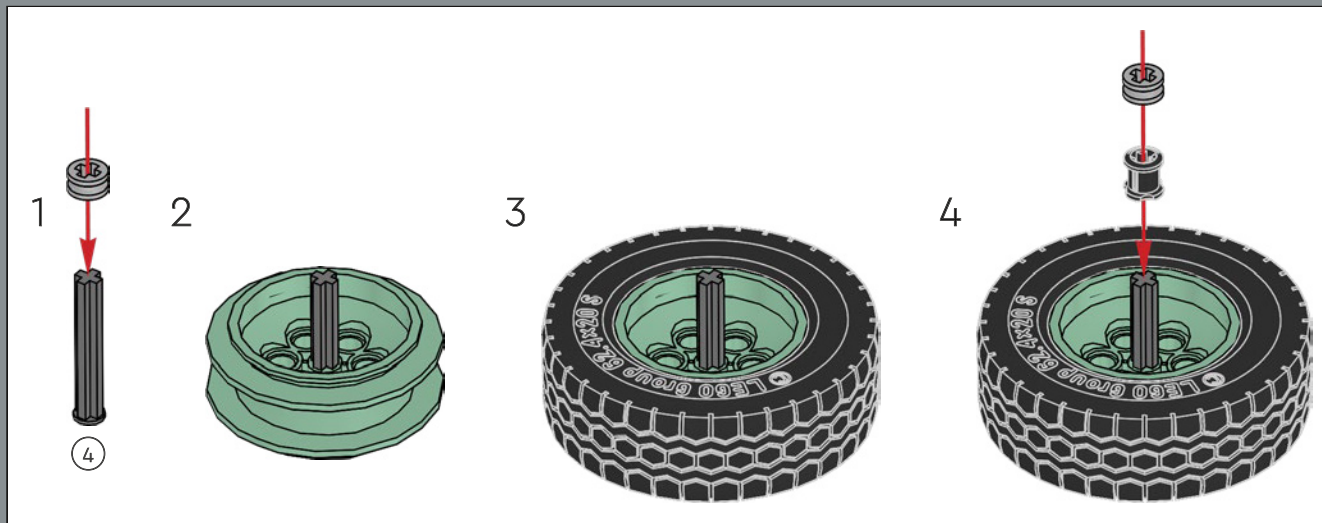

The Land Rover Defender name was added in 1990 to distinguish the classic model from the newly released Discovery range.

Le nom « Land Rover Defender » a été introduit en 1990 pour distinguer le modèle classique de la nouvelle gamme Discovery.

El nombre Land Rover Defender se añadió en 1990 para distinguir el modelo clásico de la recién lanzada gama Discovery.

459

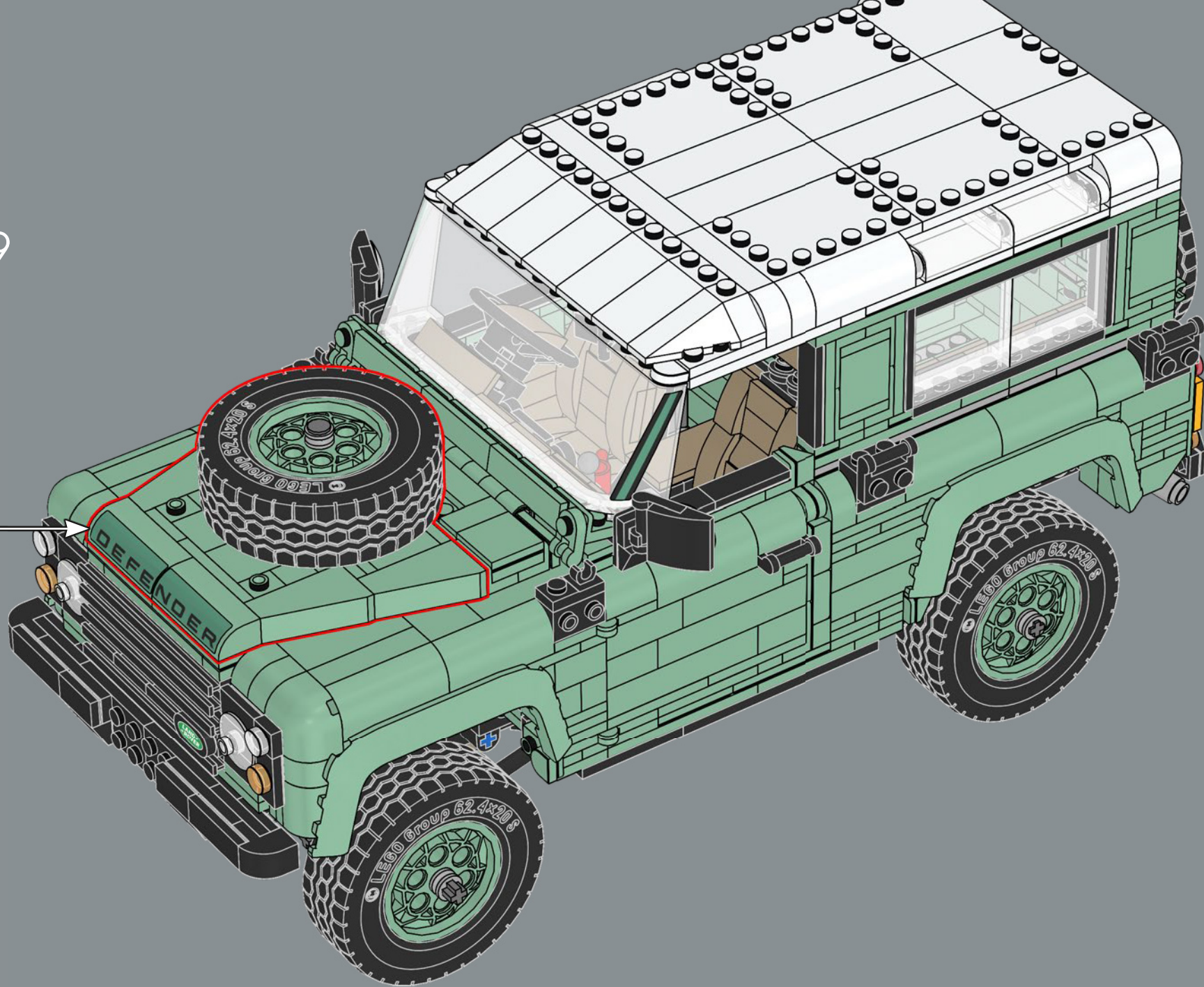

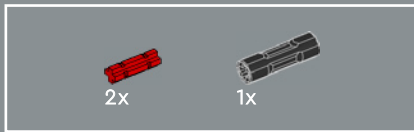
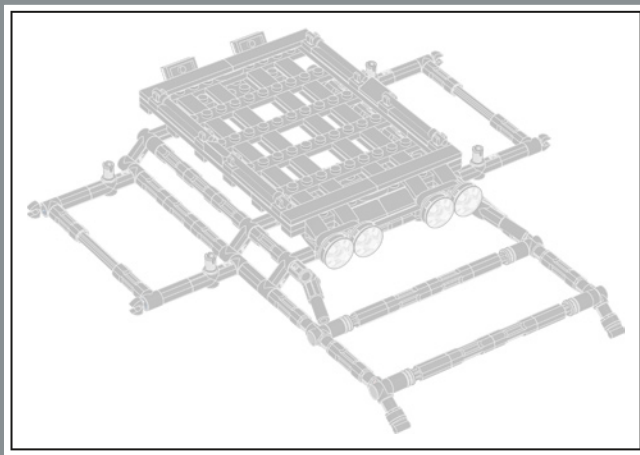

460

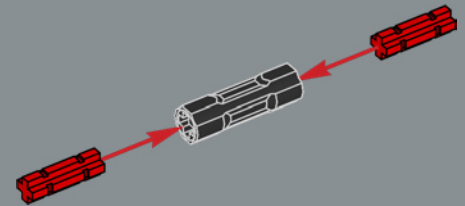

461

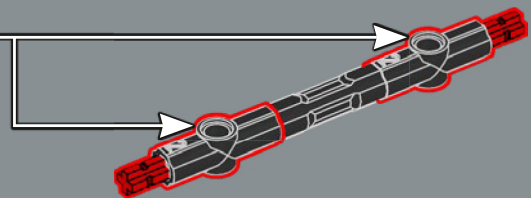
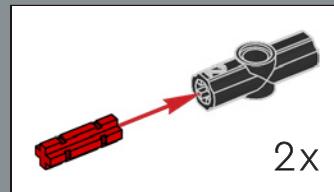



462

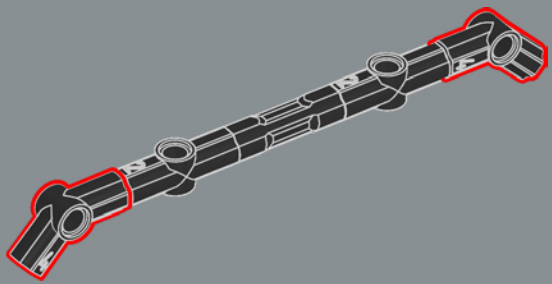

463

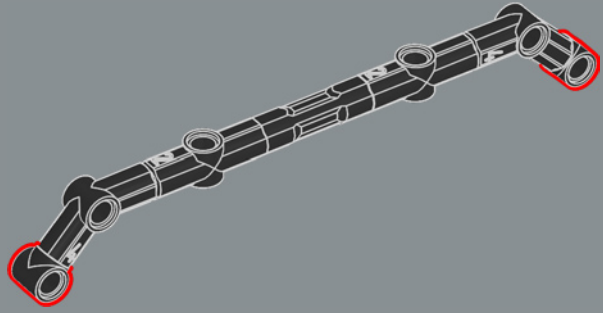

464

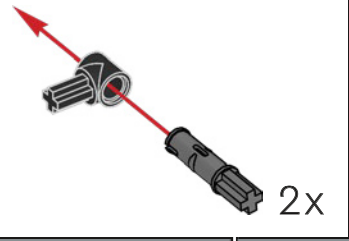
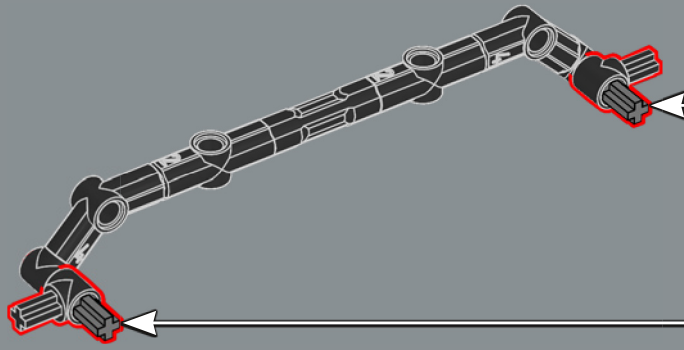

465

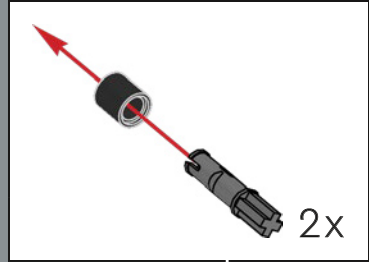
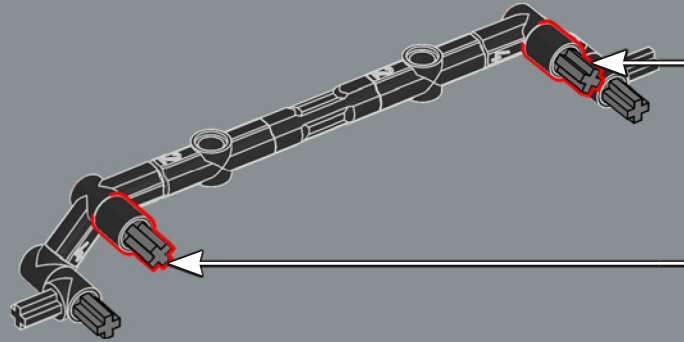



466

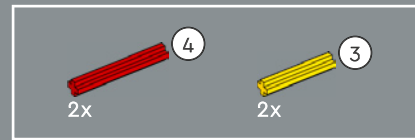
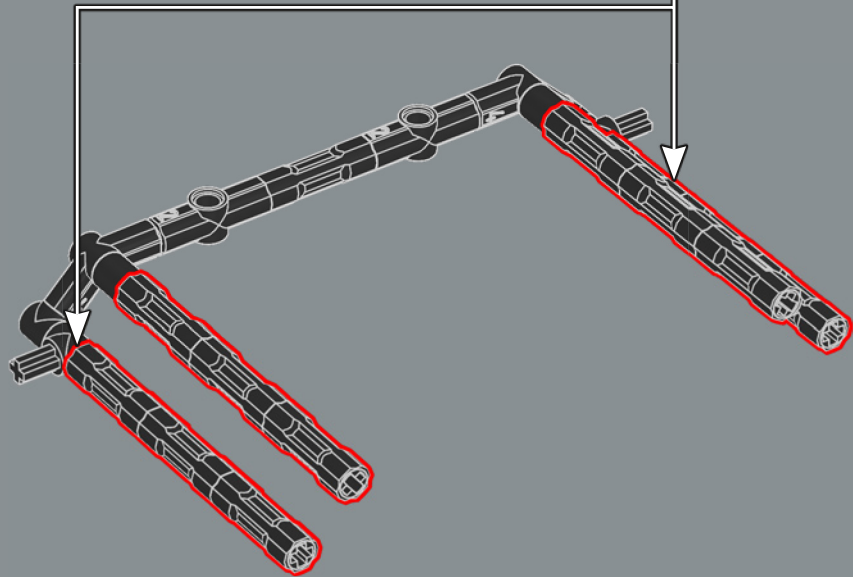
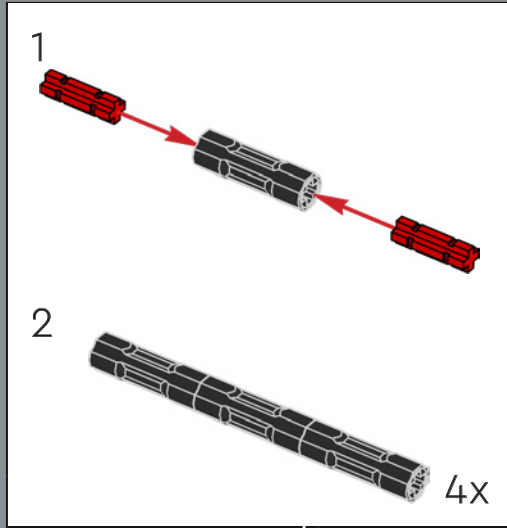

467

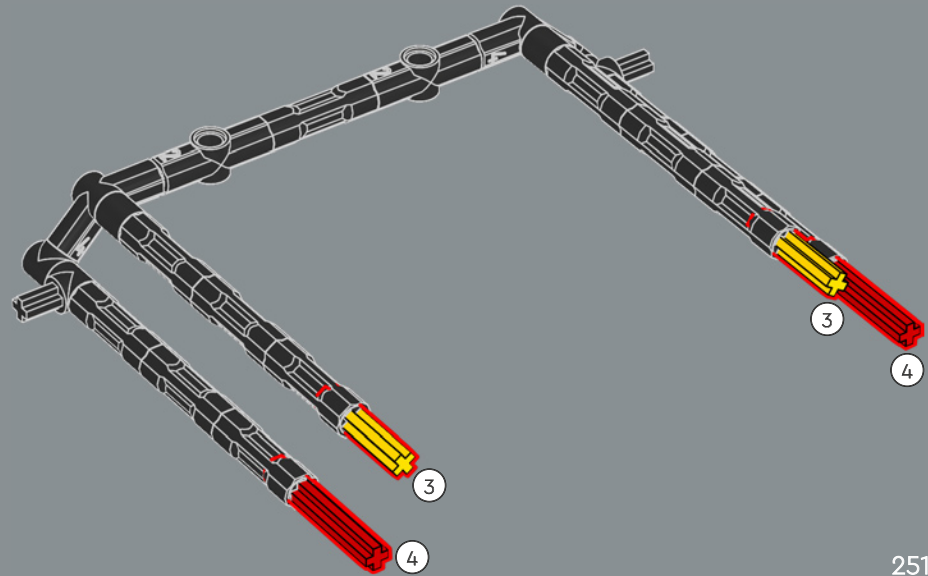
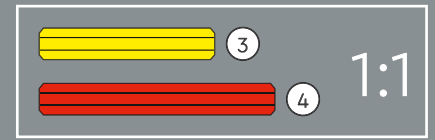

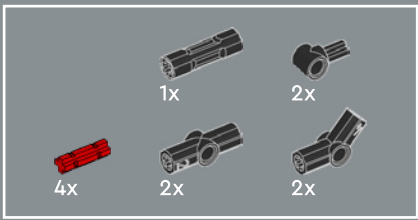

468

1

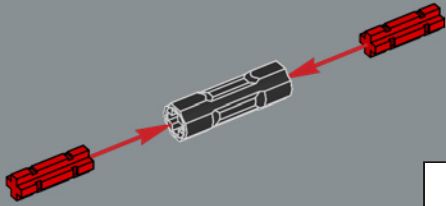

2

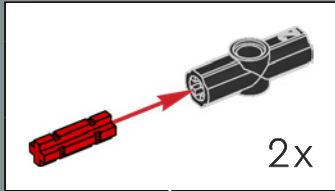
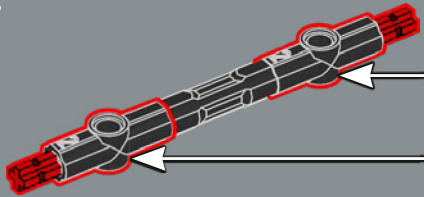

3

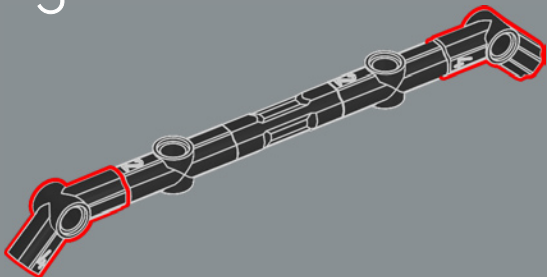

4

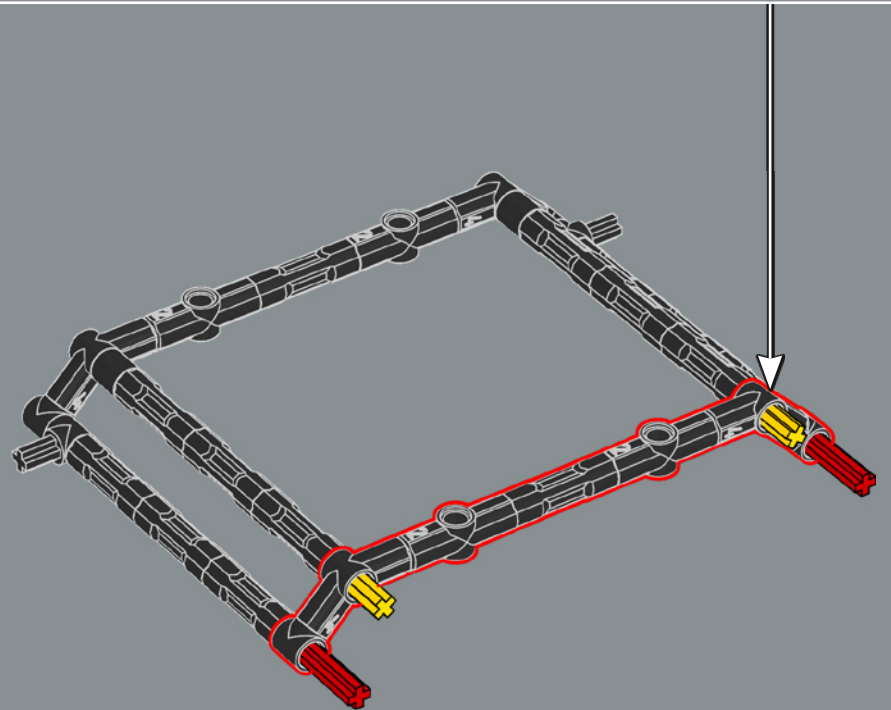
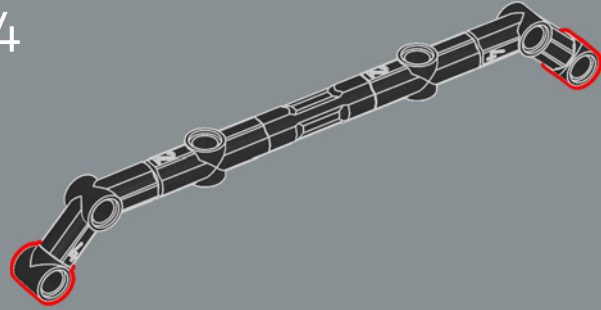



469

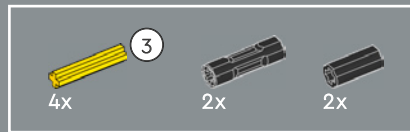
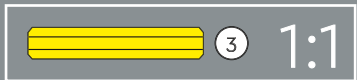
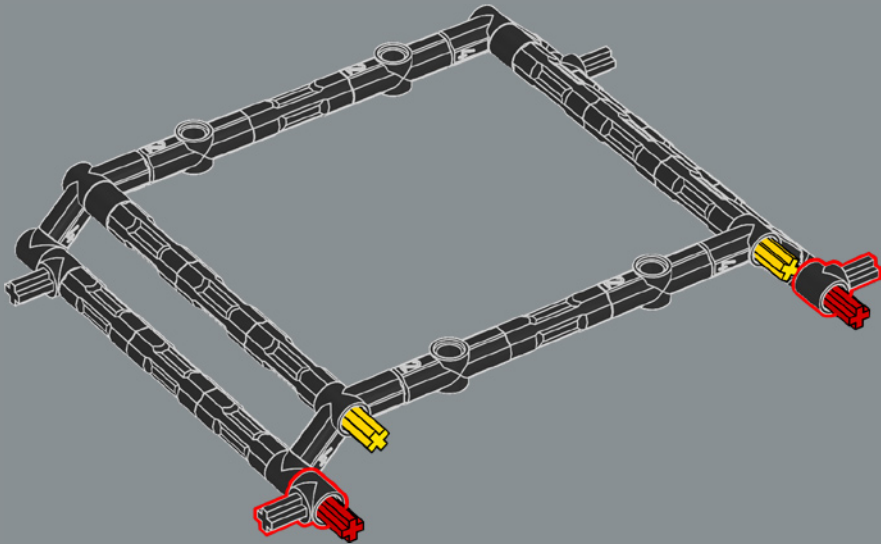

470

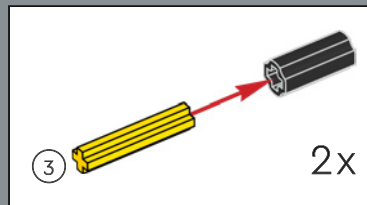
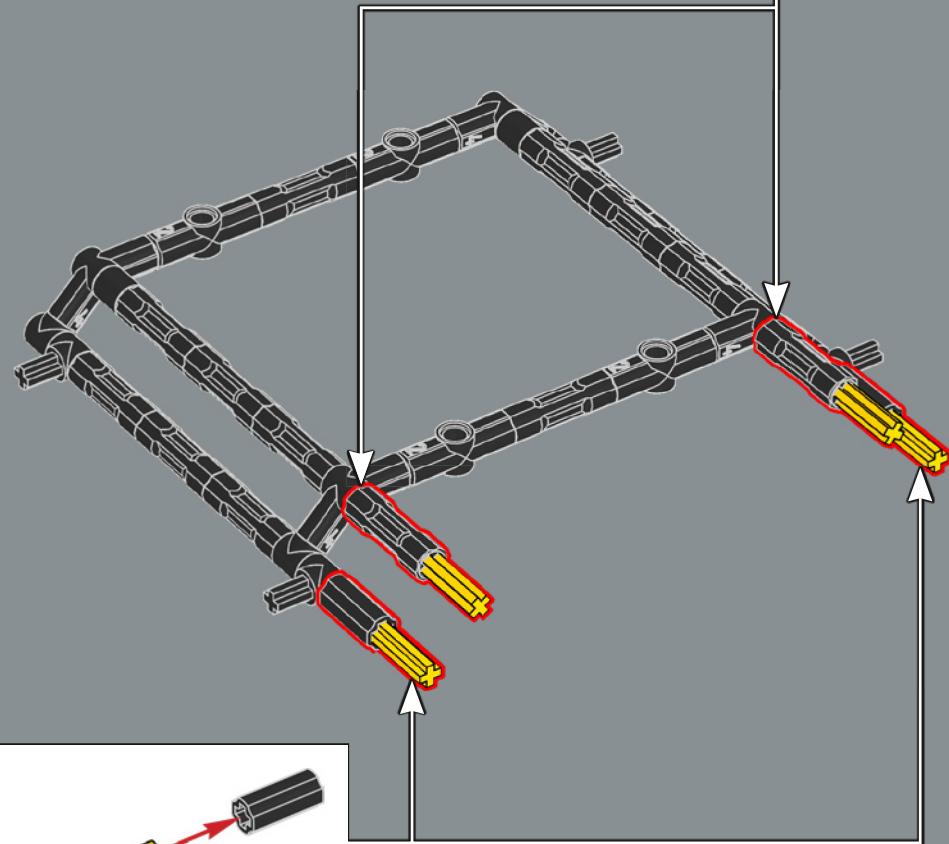
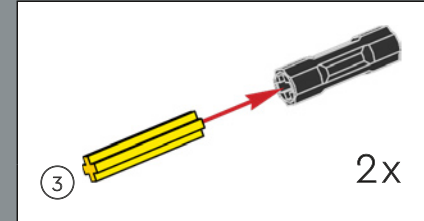

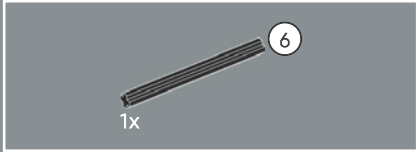
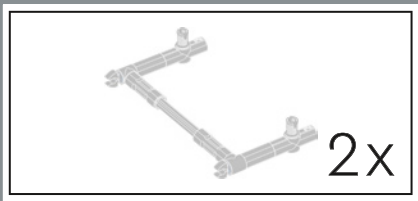

471

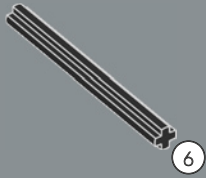

472

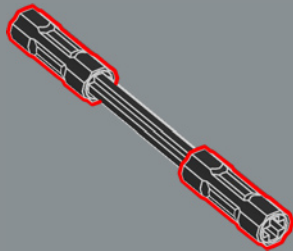

473

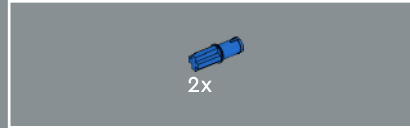
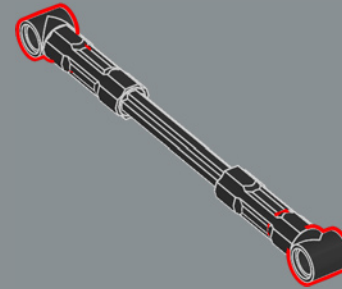

474

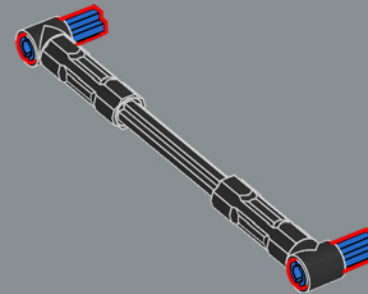



475

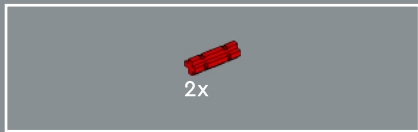
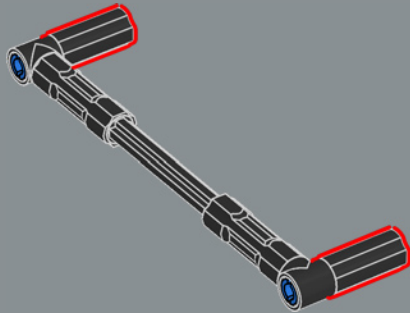

476

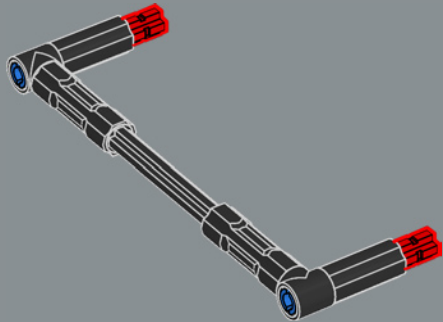

477

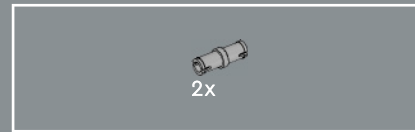
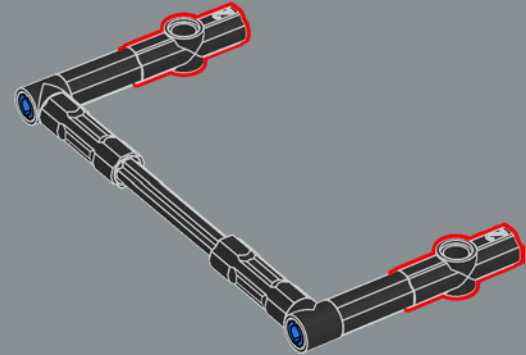

478

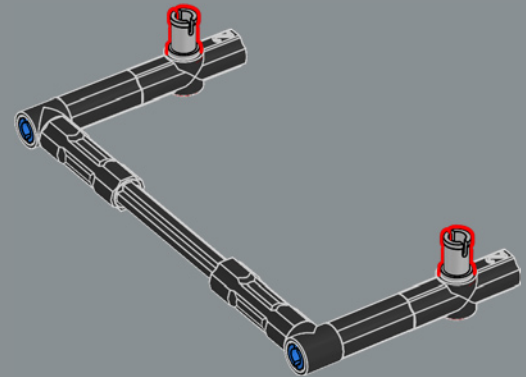



2x

479

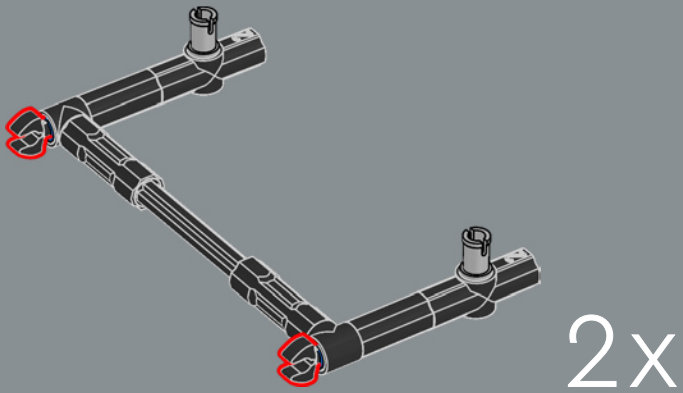

480

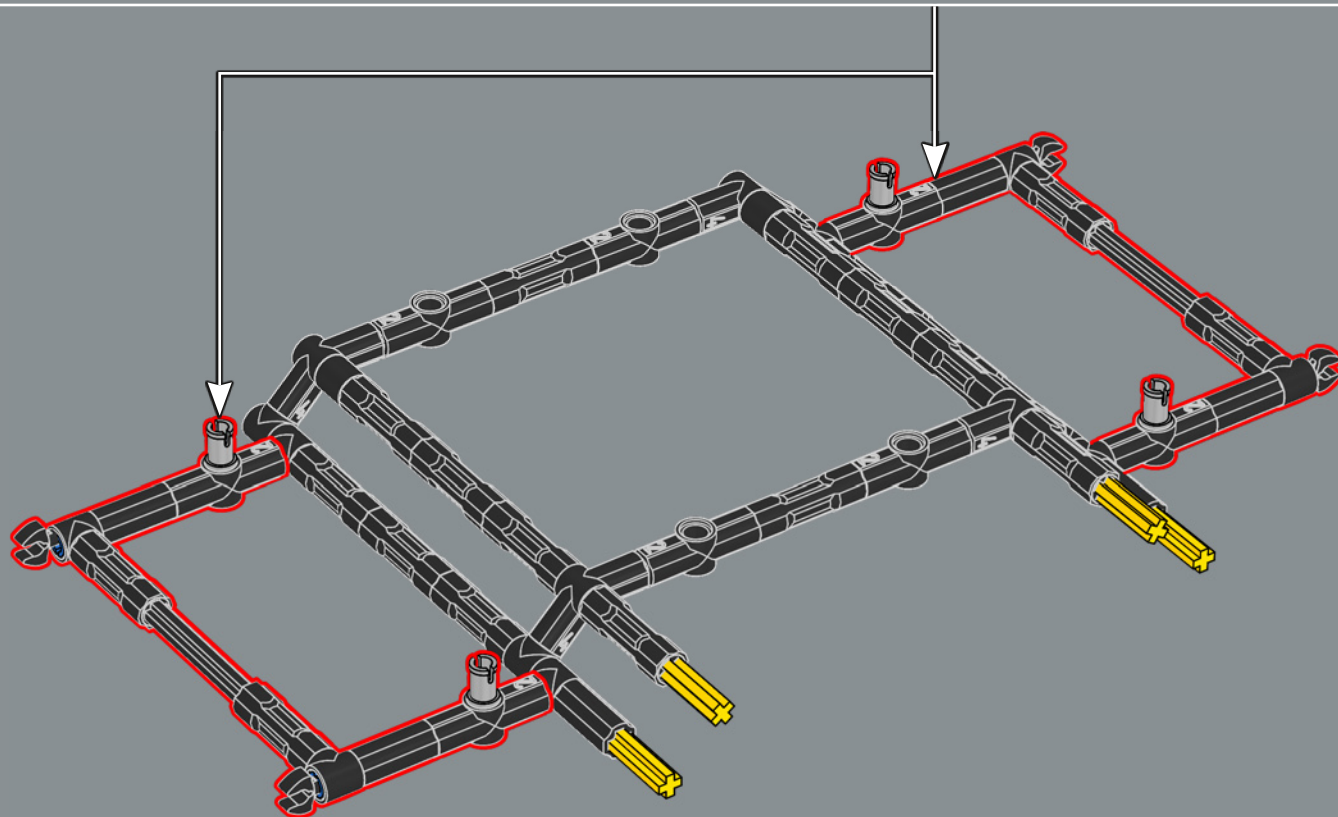

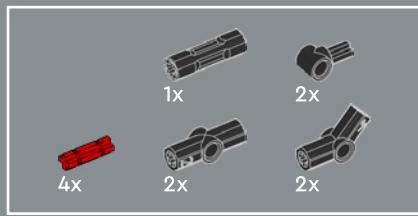

481

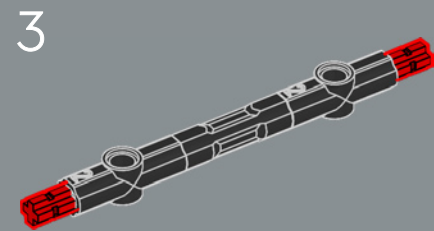
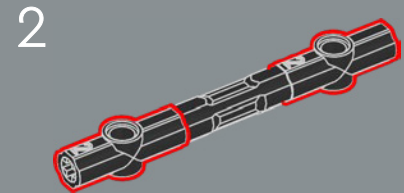
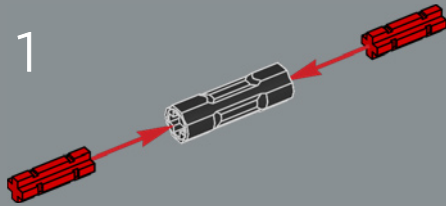

4

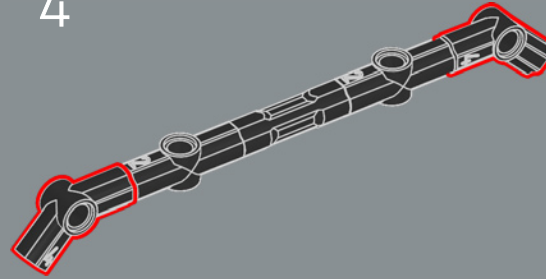

5

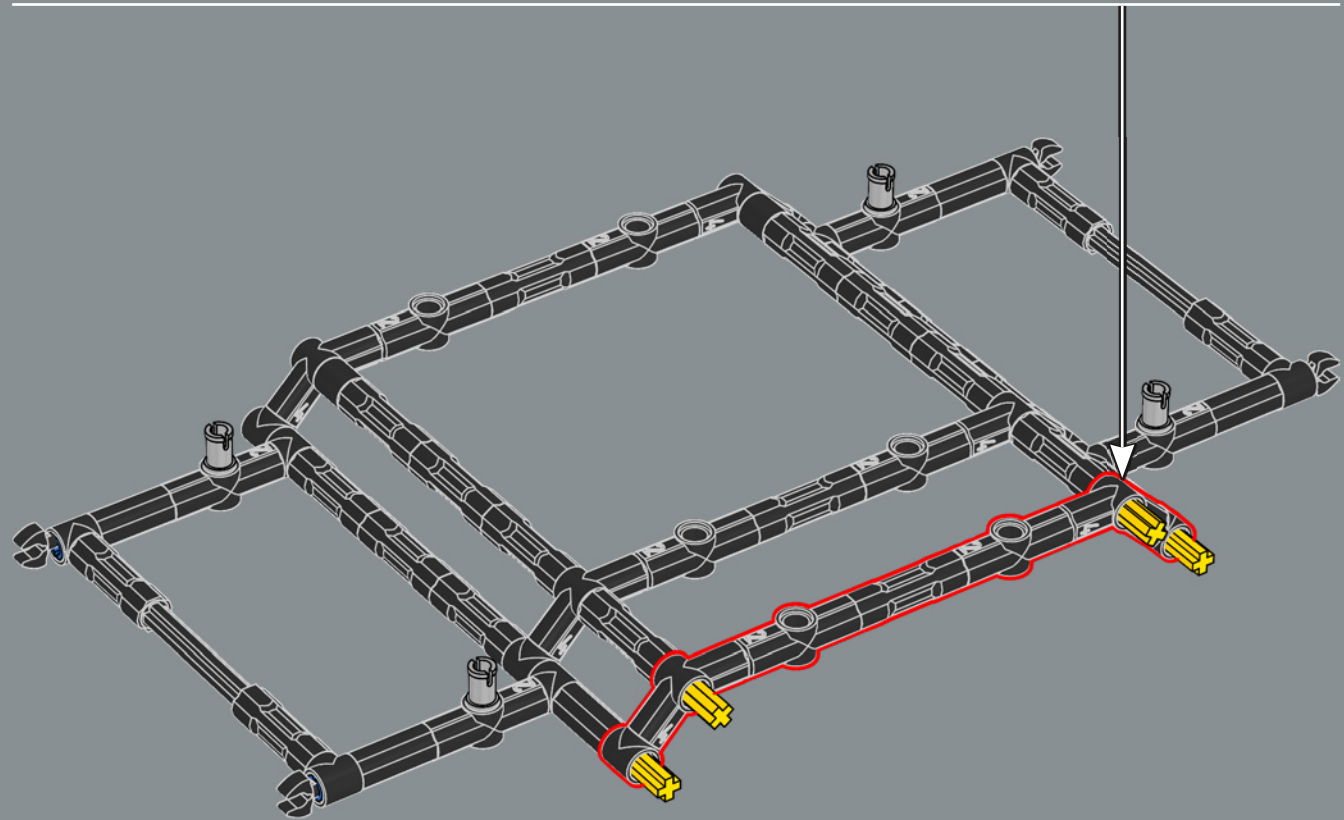
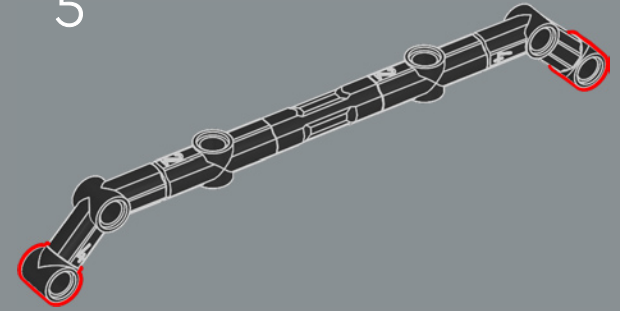



482

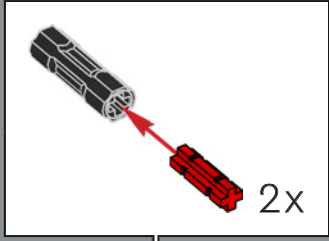
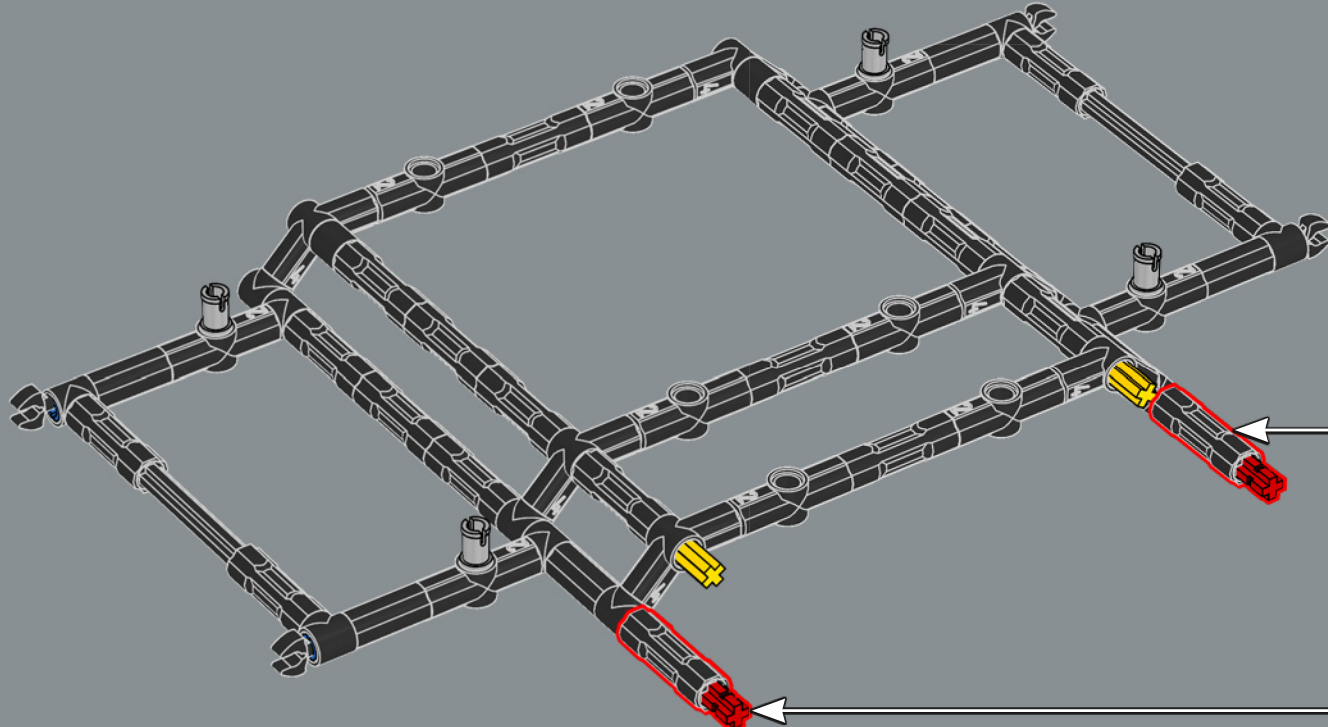

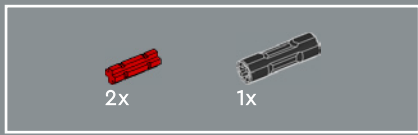

483

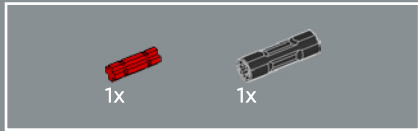
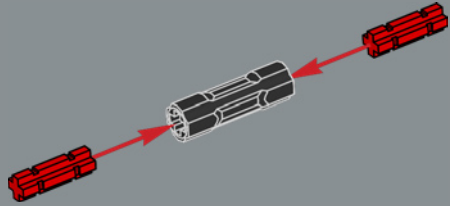

484

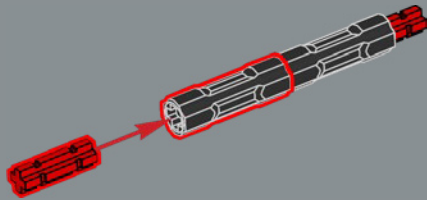

485

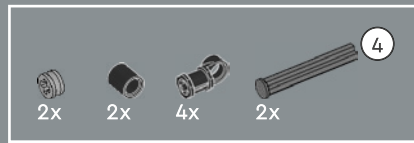
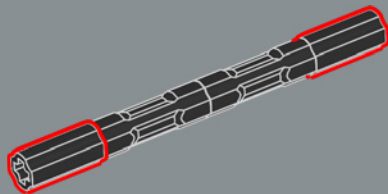

486

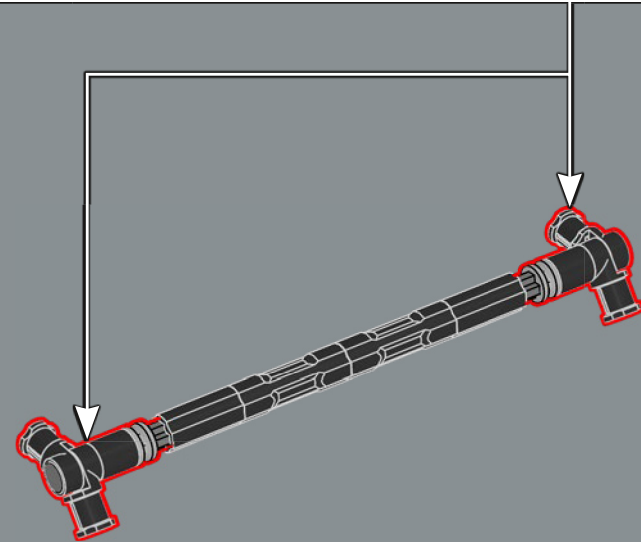
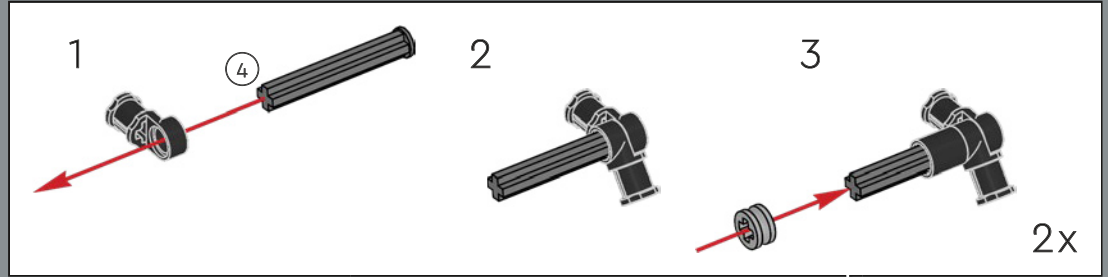

487

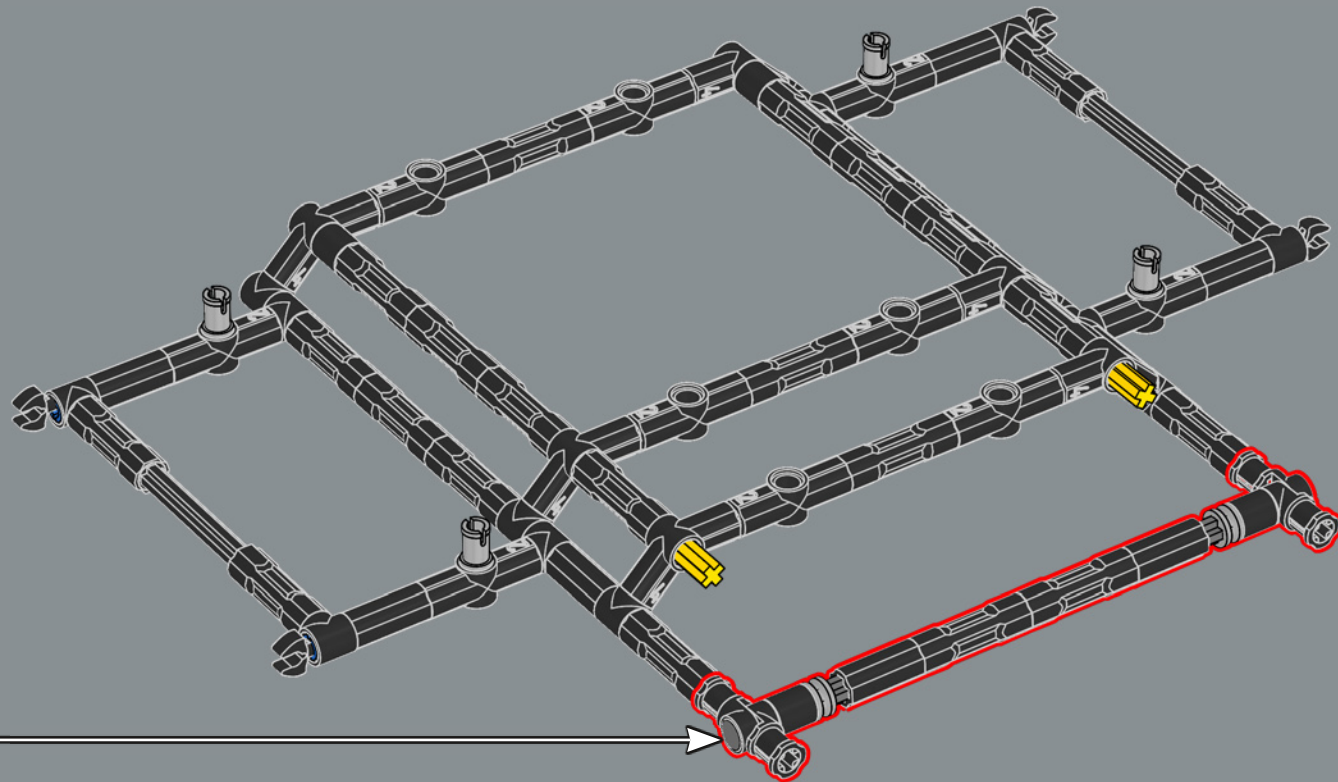

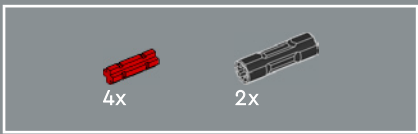

488

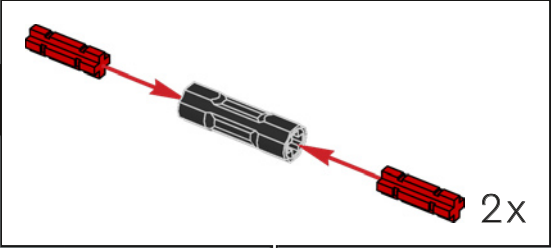
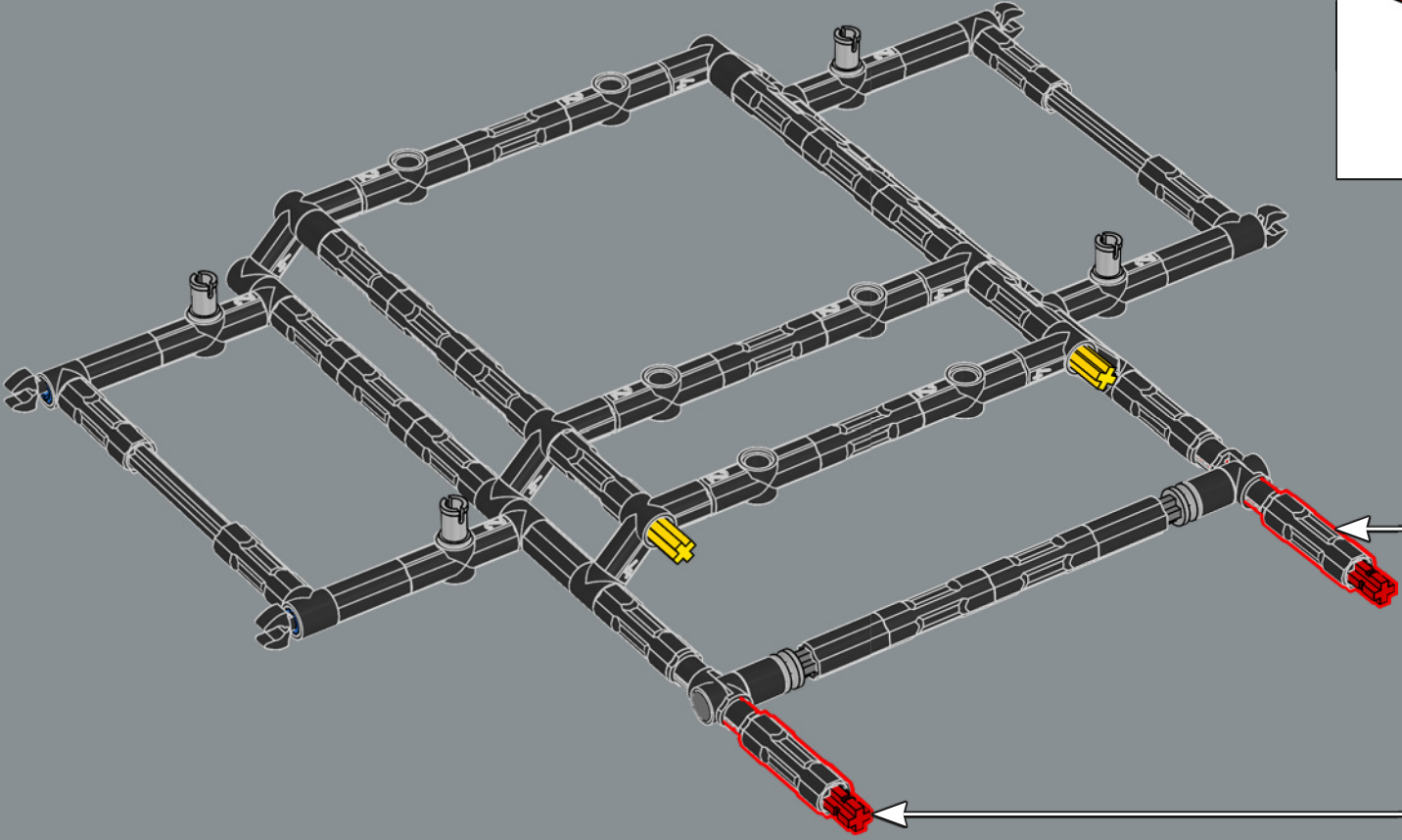

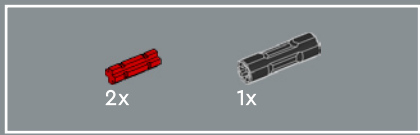

489

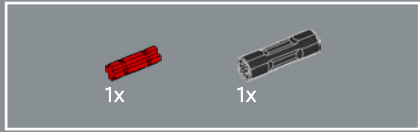
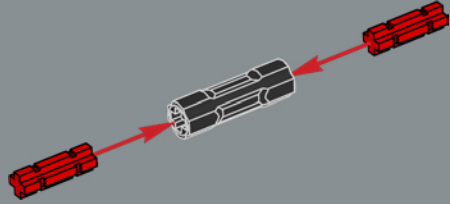

490

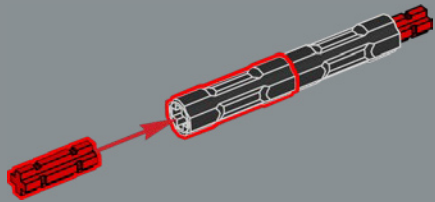

491

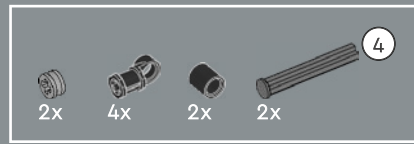
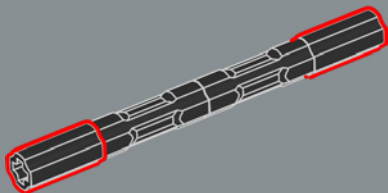

492

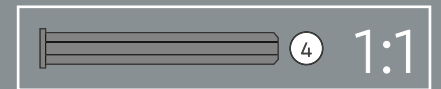
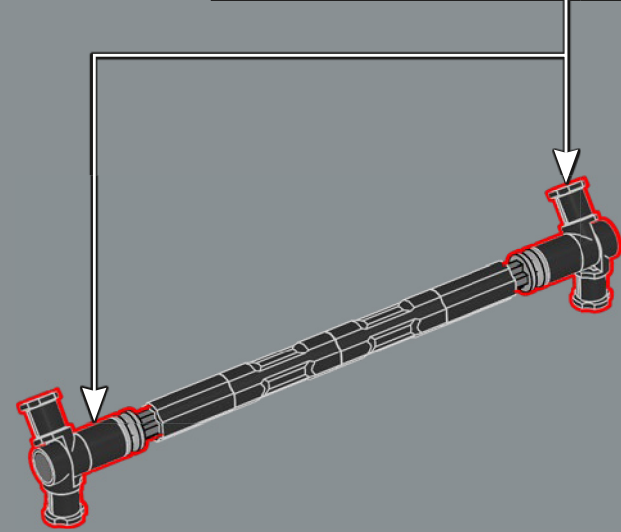
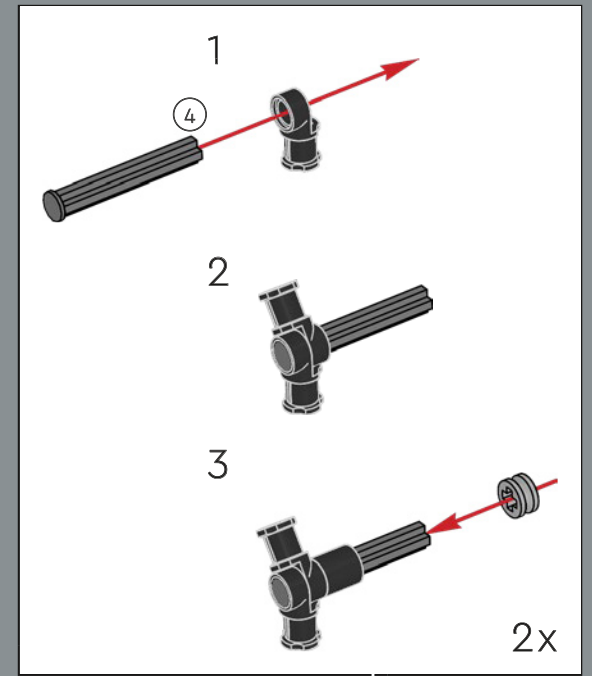



493

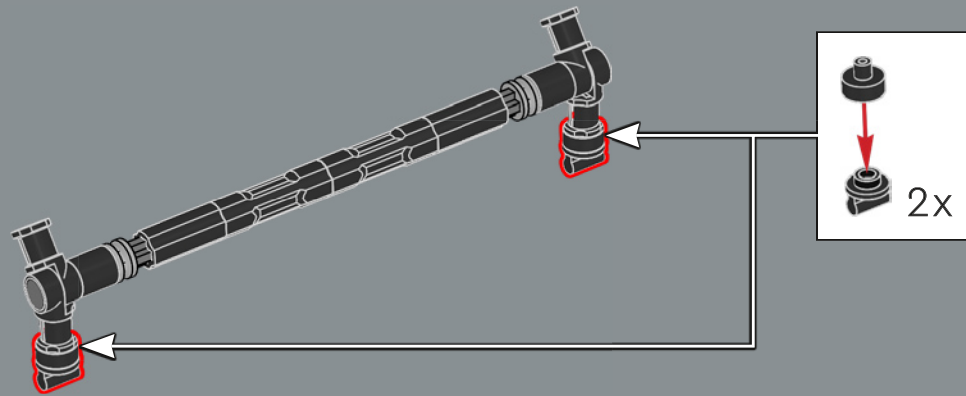

494

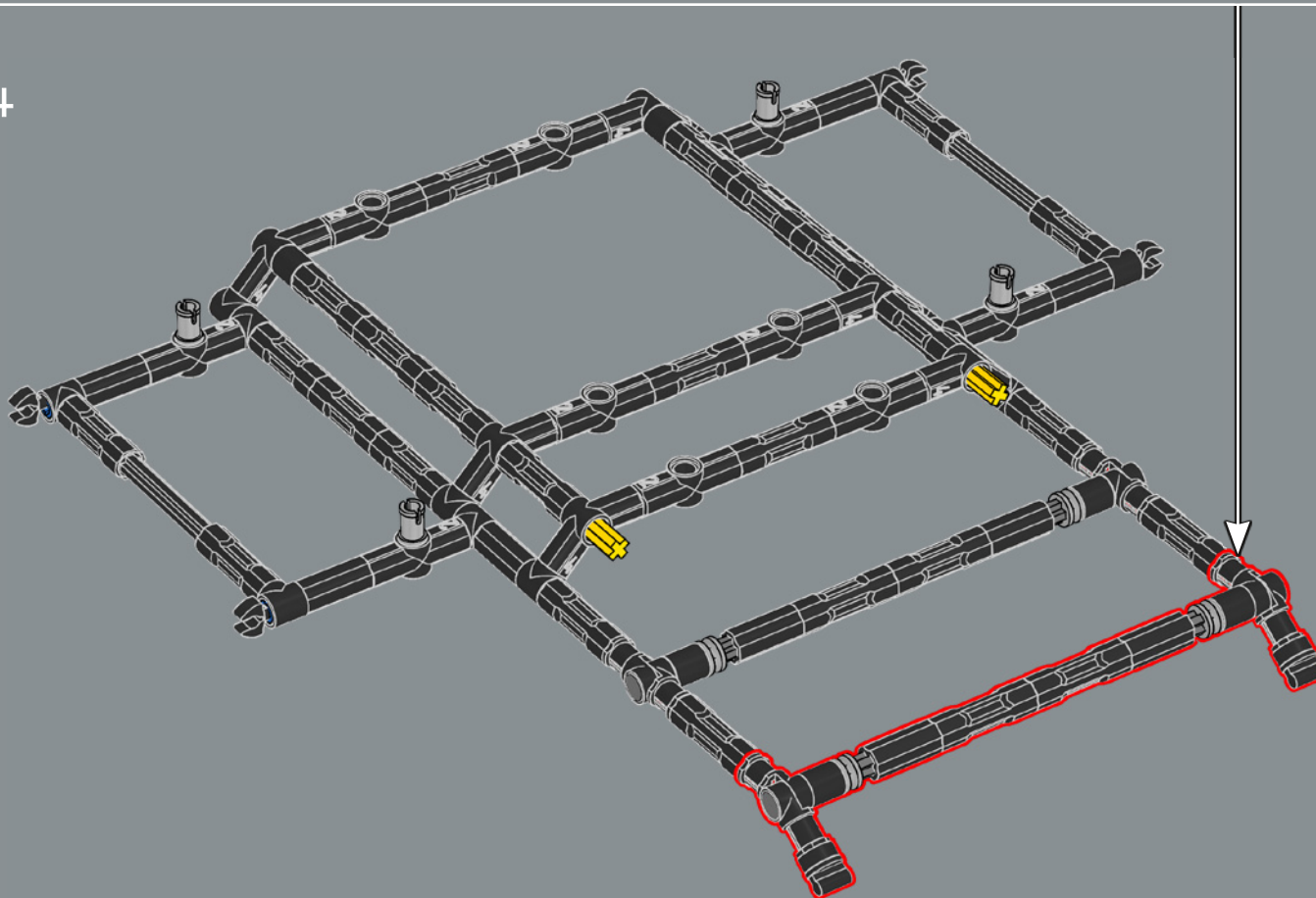

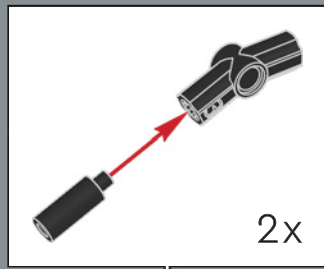

495

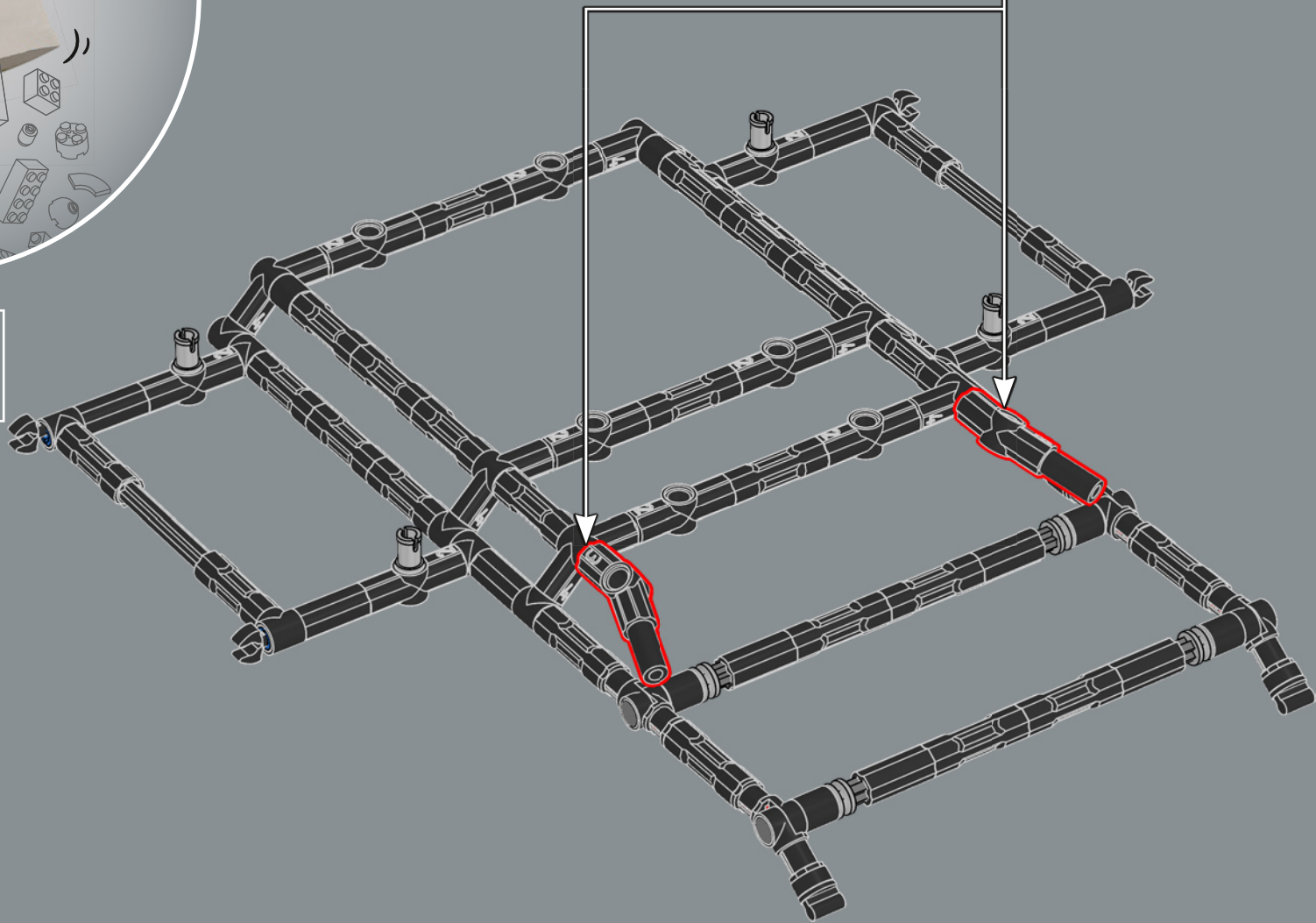

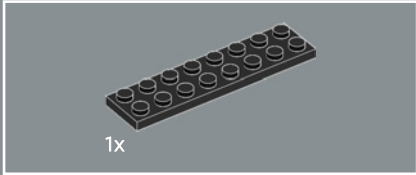
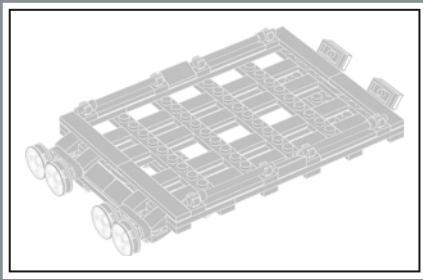

1x

496

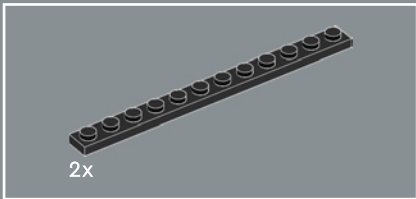
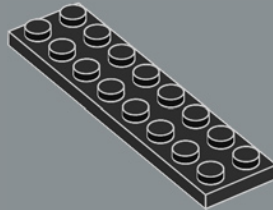

2x

497

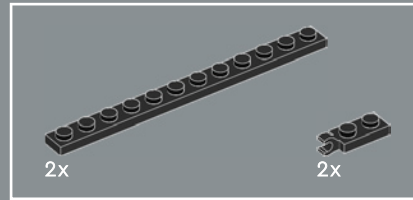
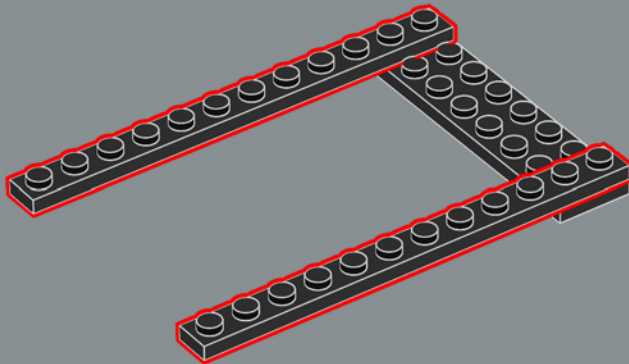

2x

2x

498

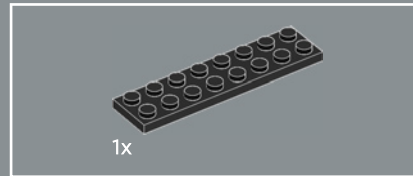
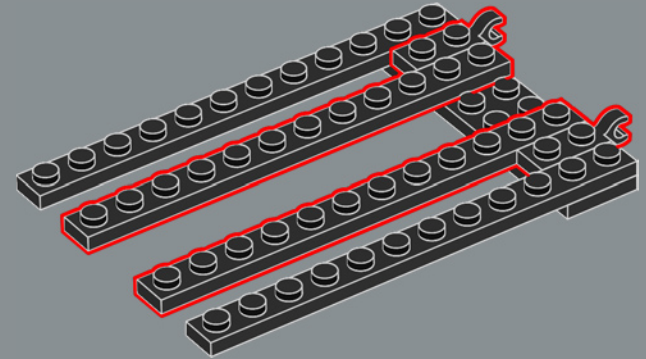

1x

499

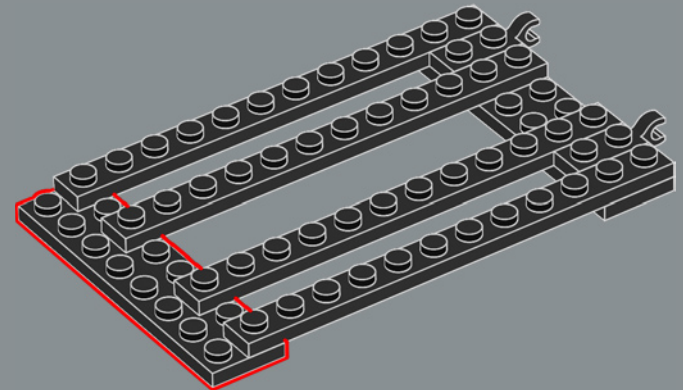

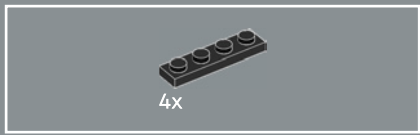

500

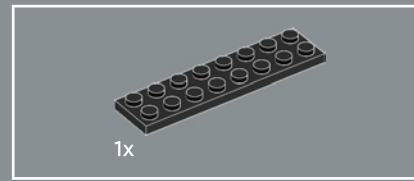
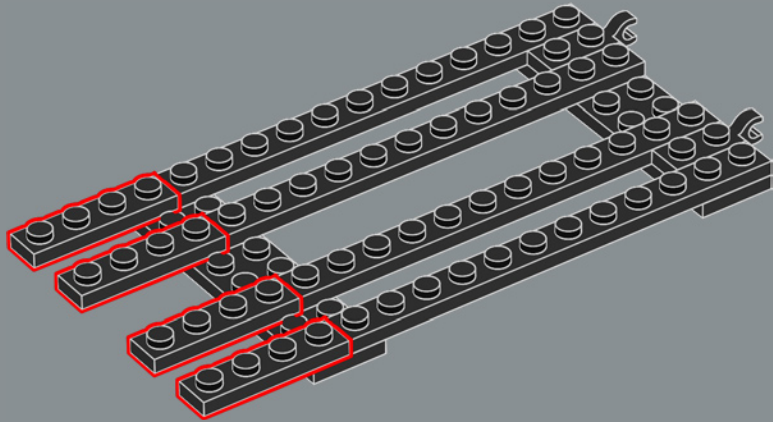

501

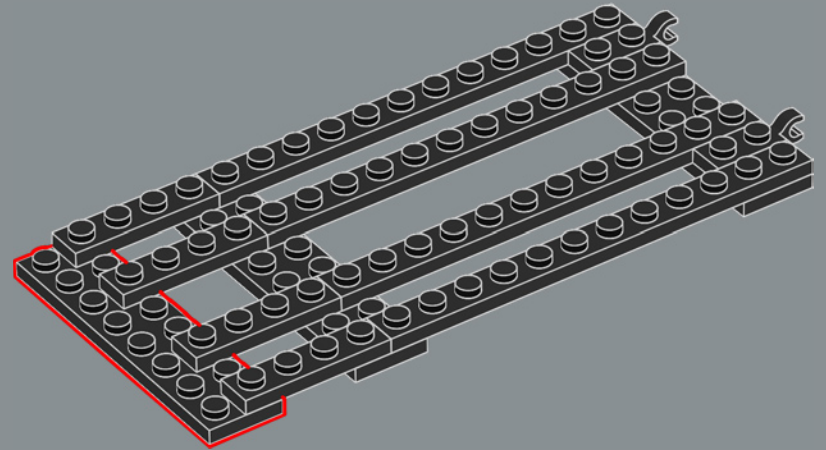



502

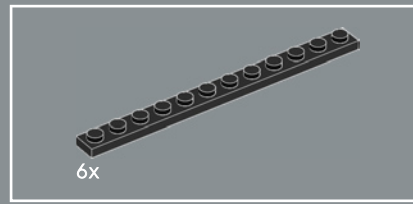
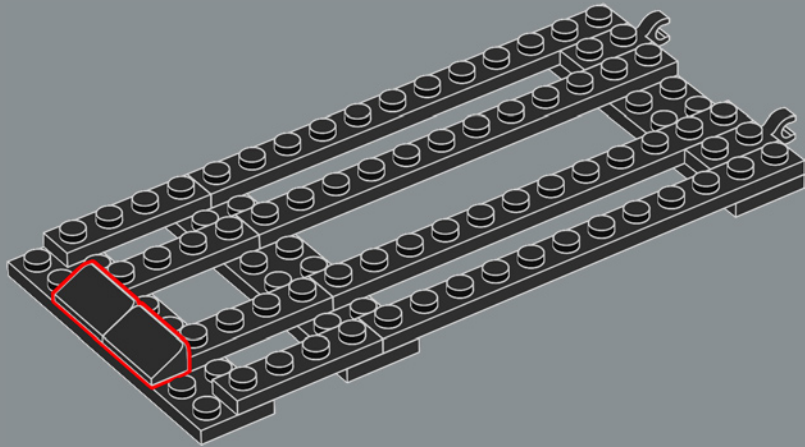

503

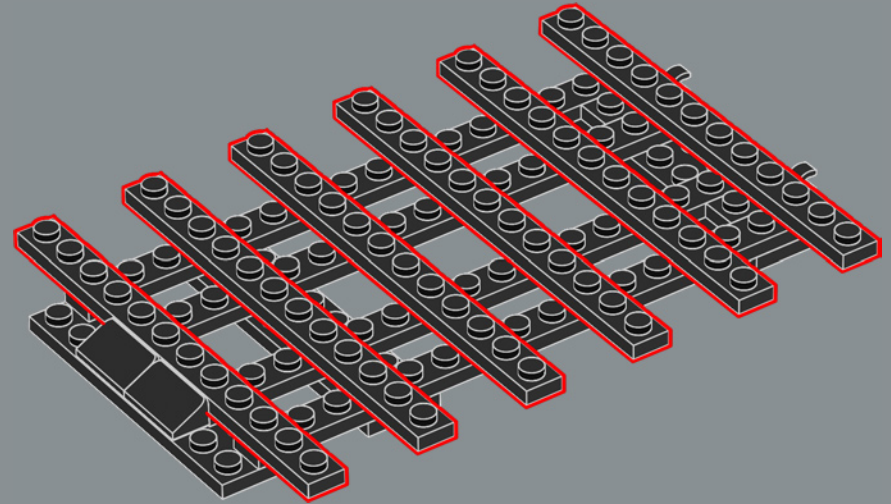



20x

504

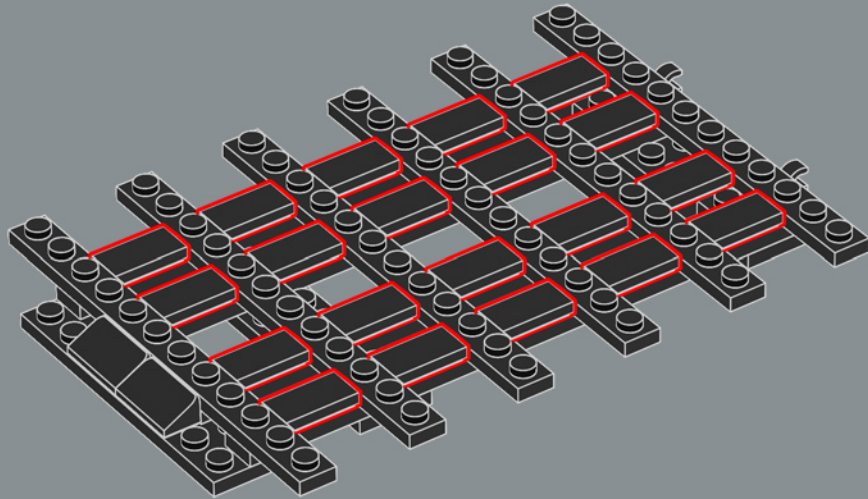

2x

505

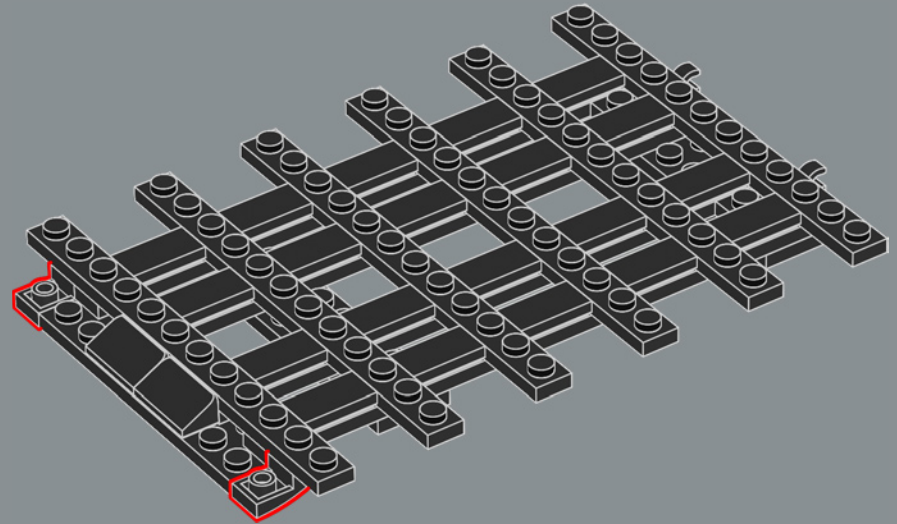



506

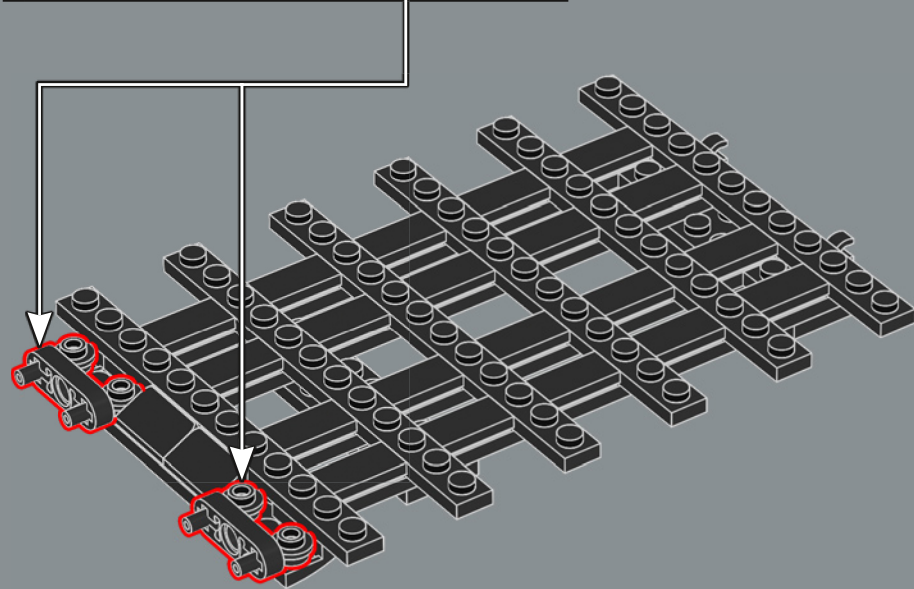
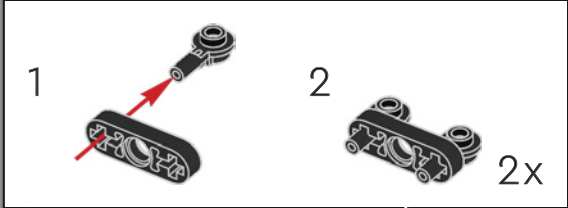

507

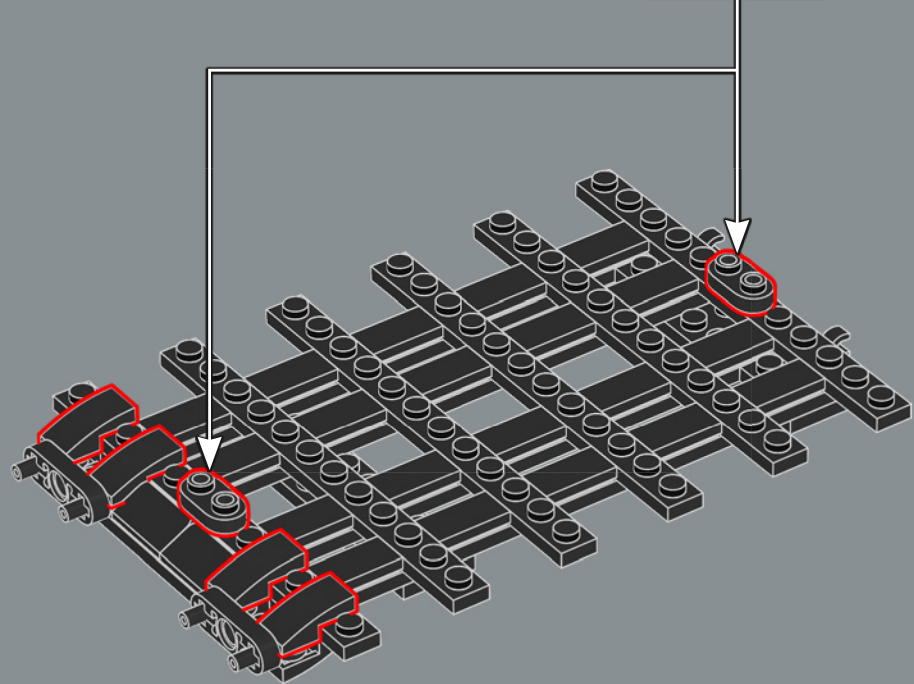

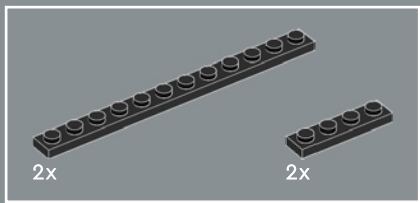

508

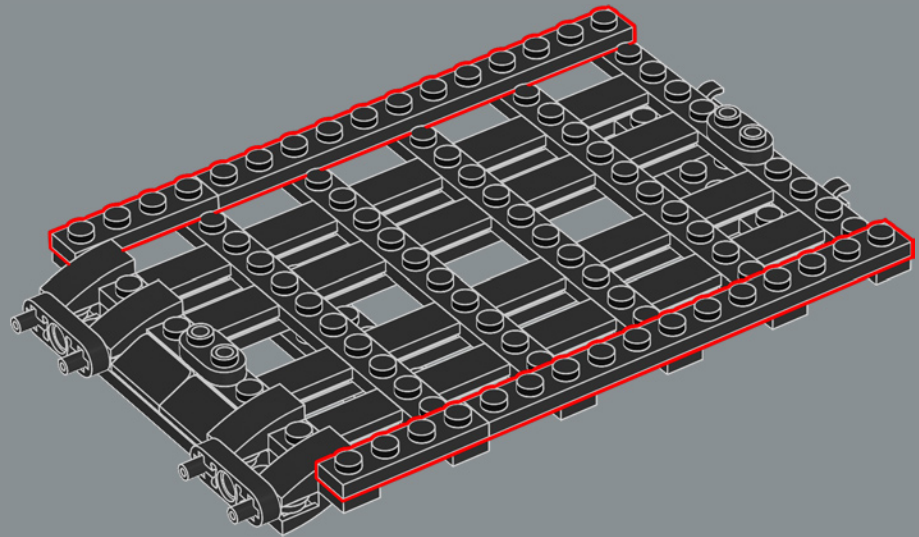

509

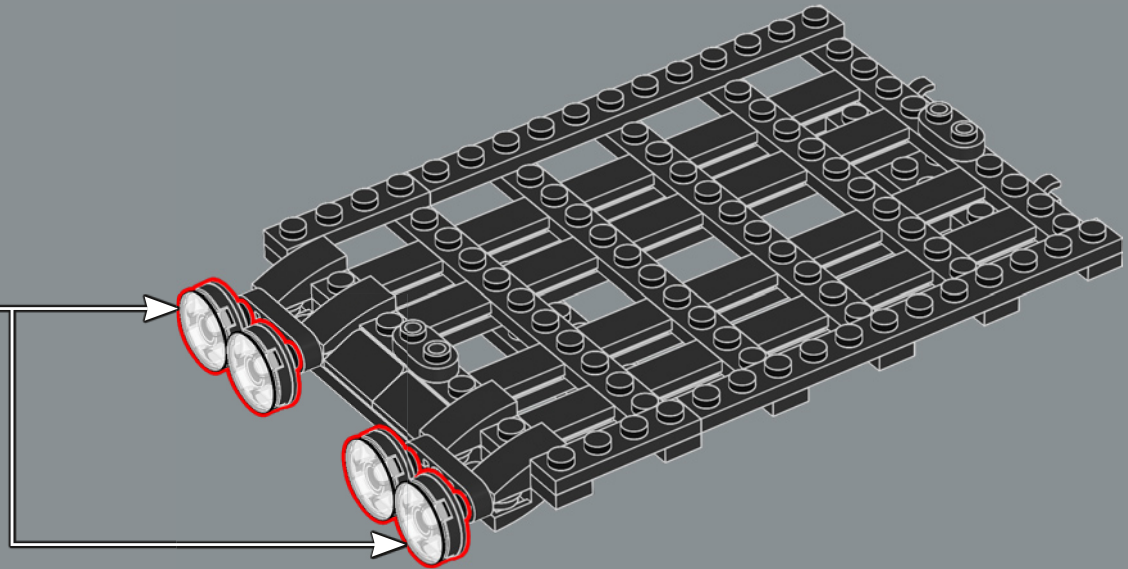
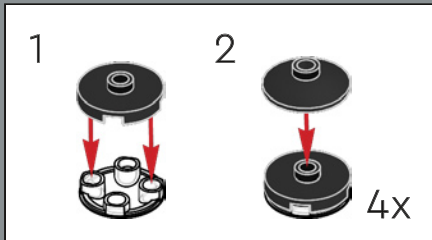



510

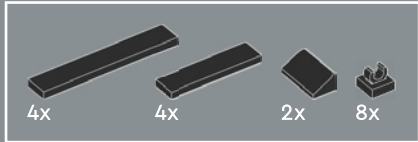
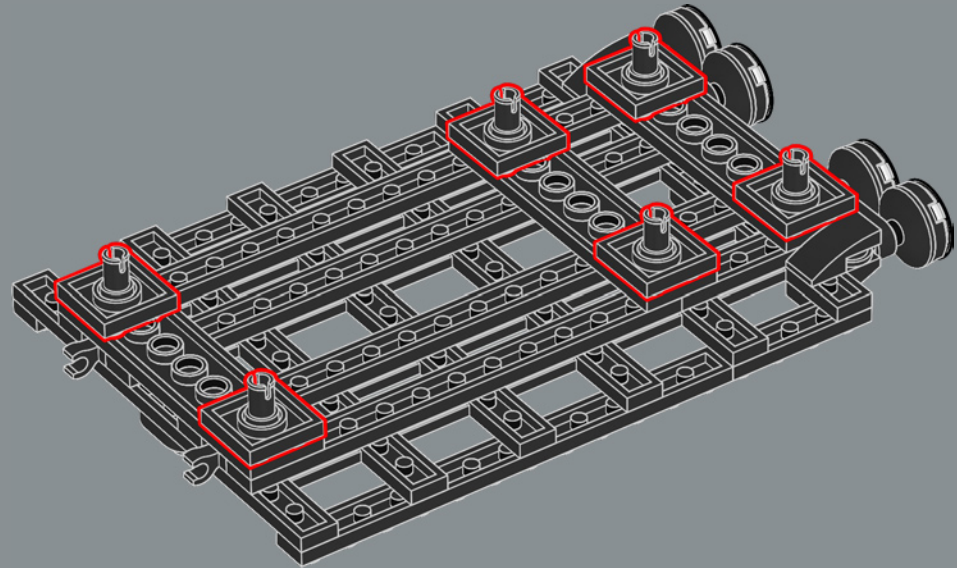

511

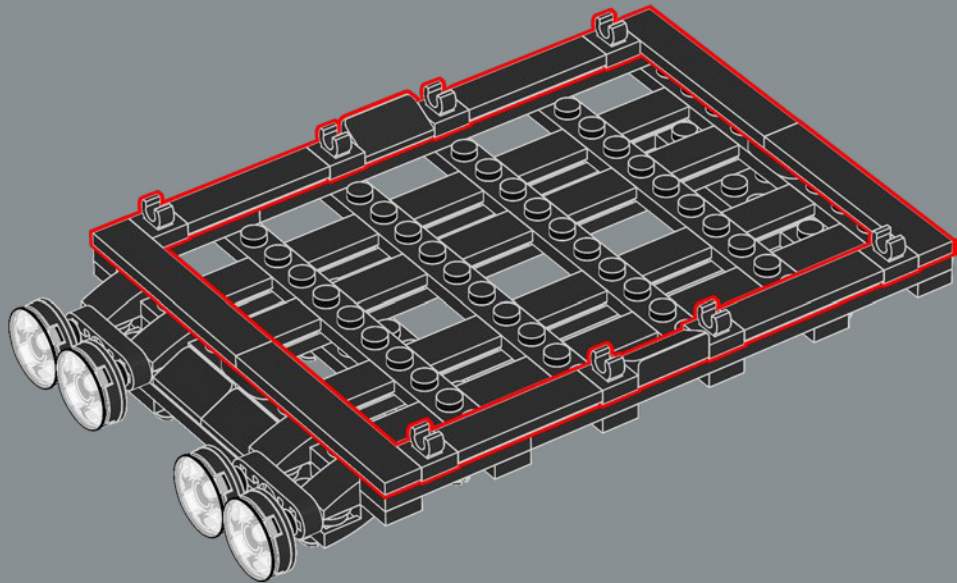



512

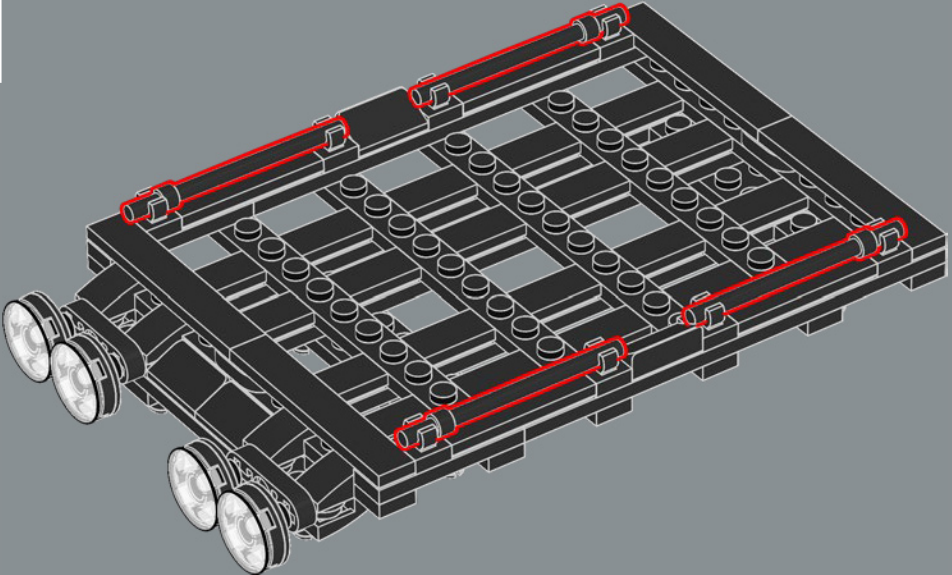

513

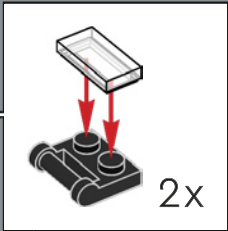
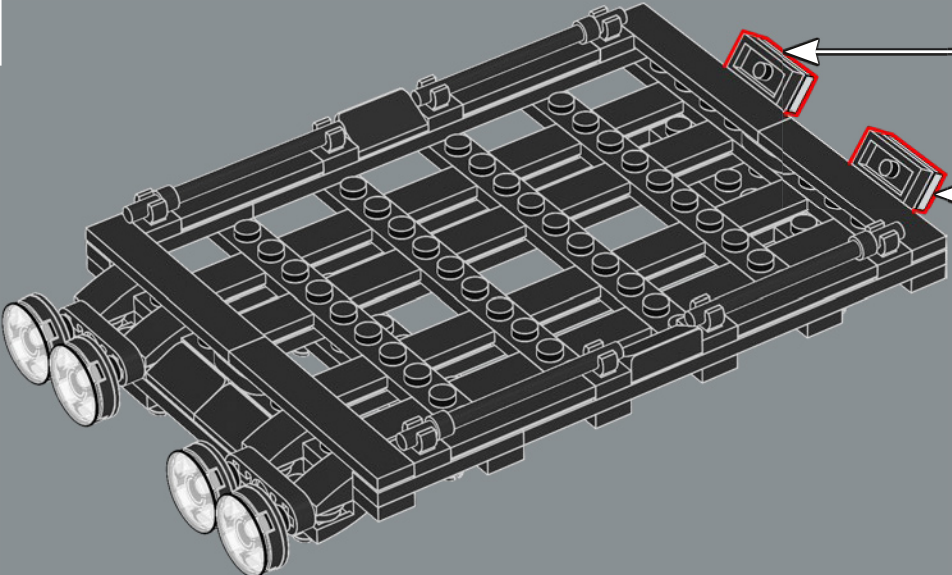

514

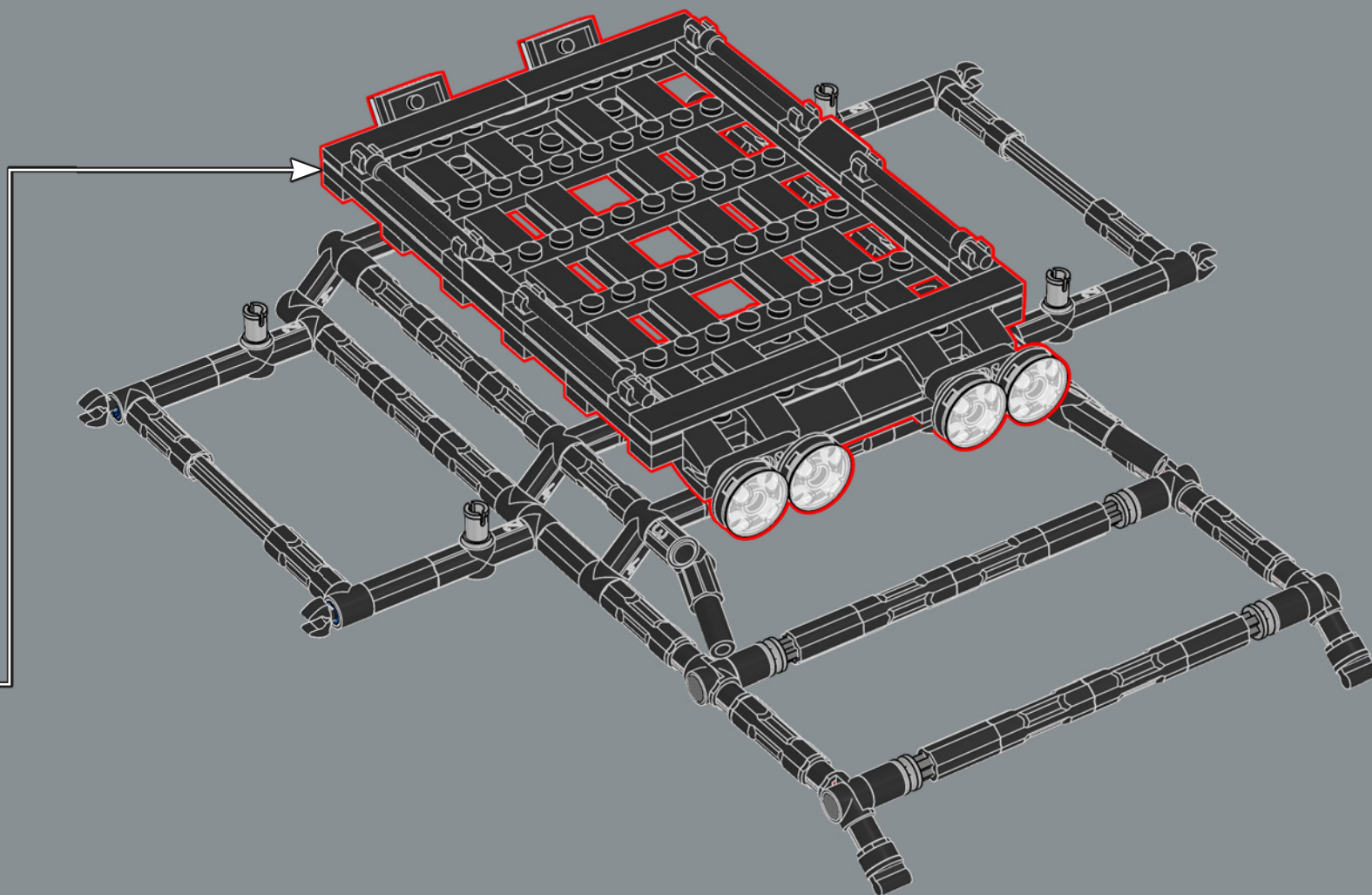

515

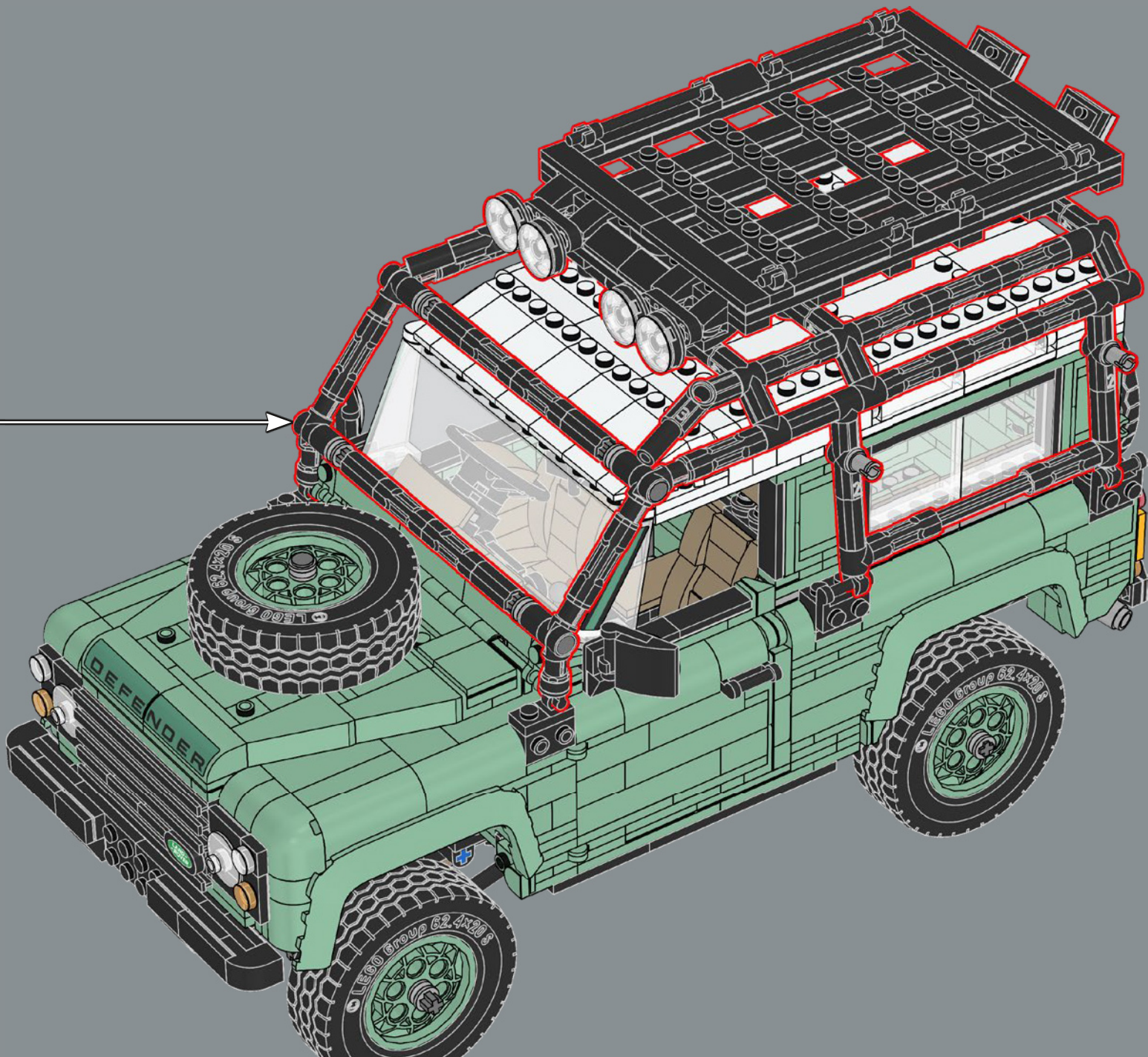

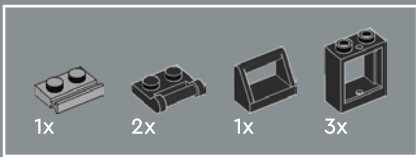

516

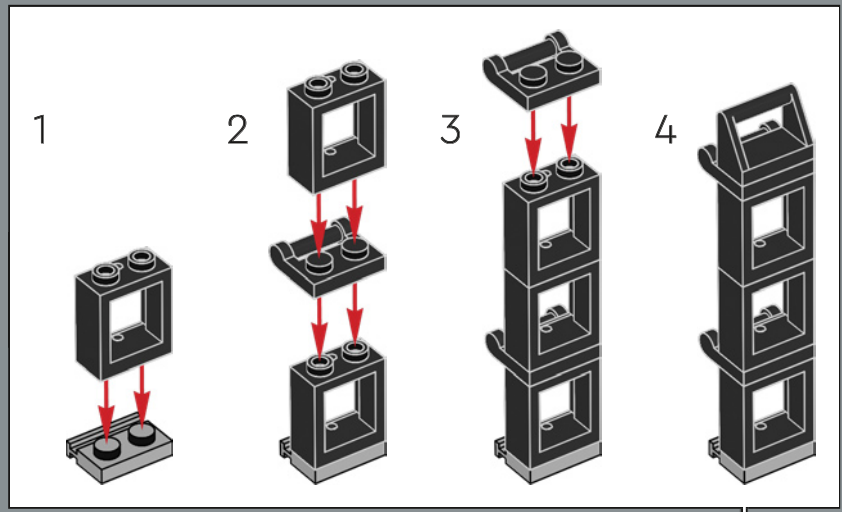
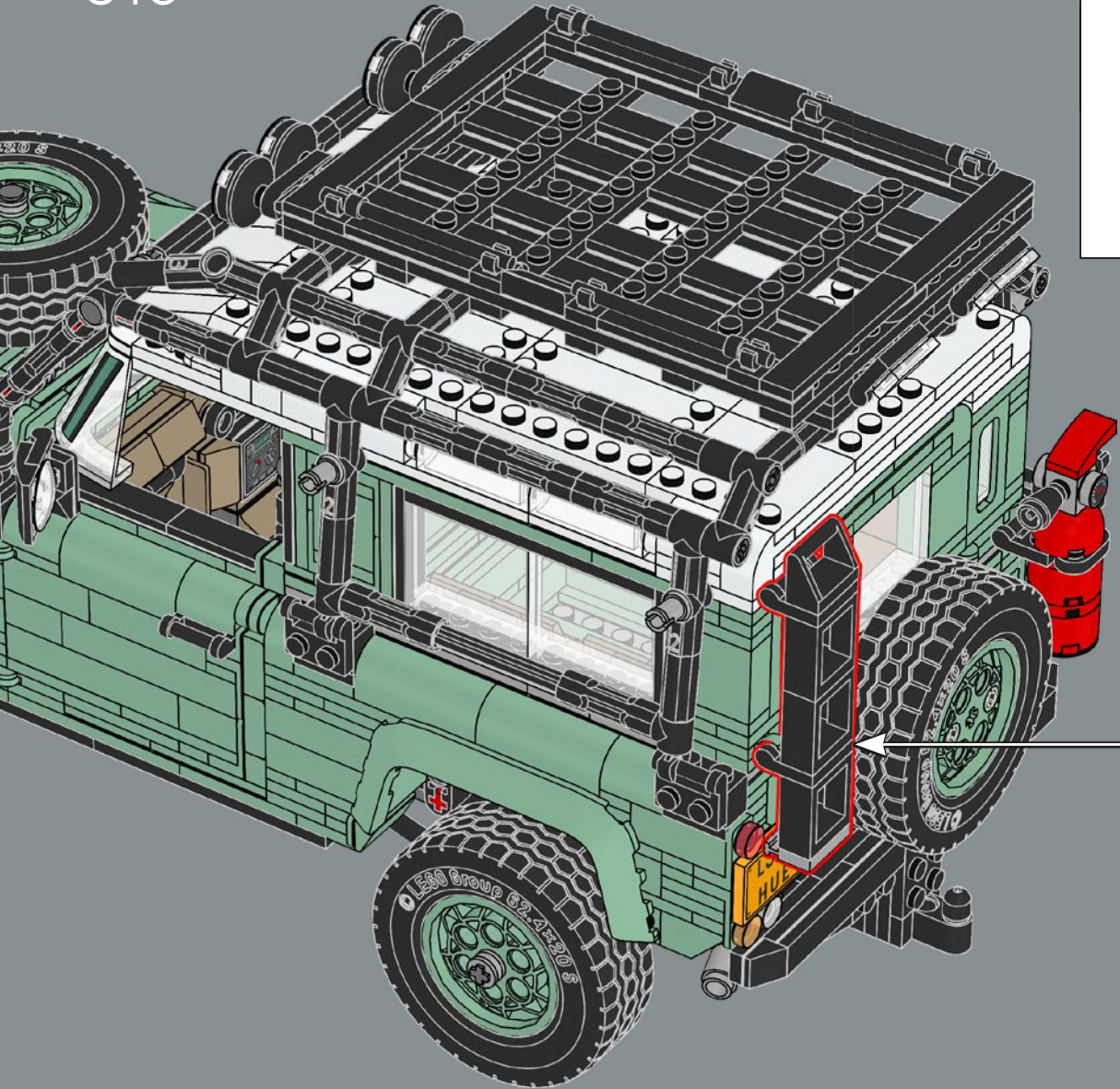

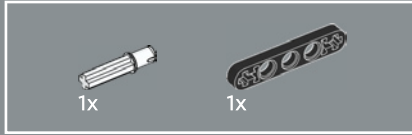
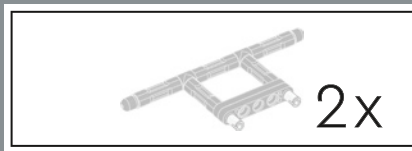

517

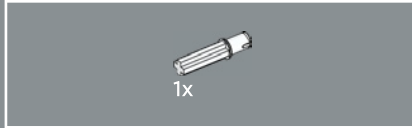
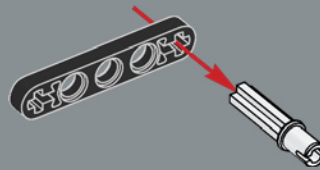

518

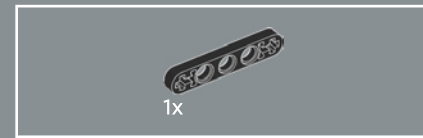
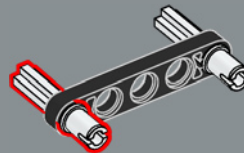

519

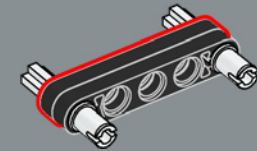

520

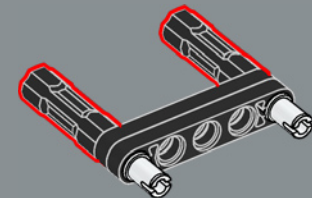

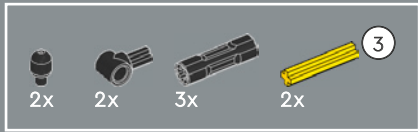

521

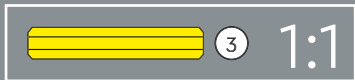
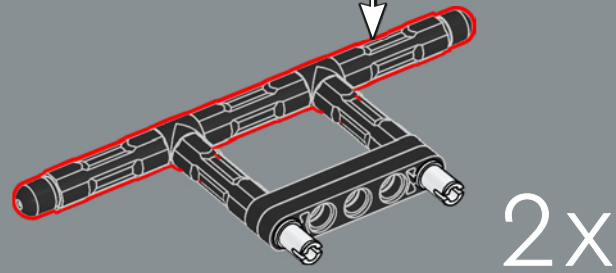
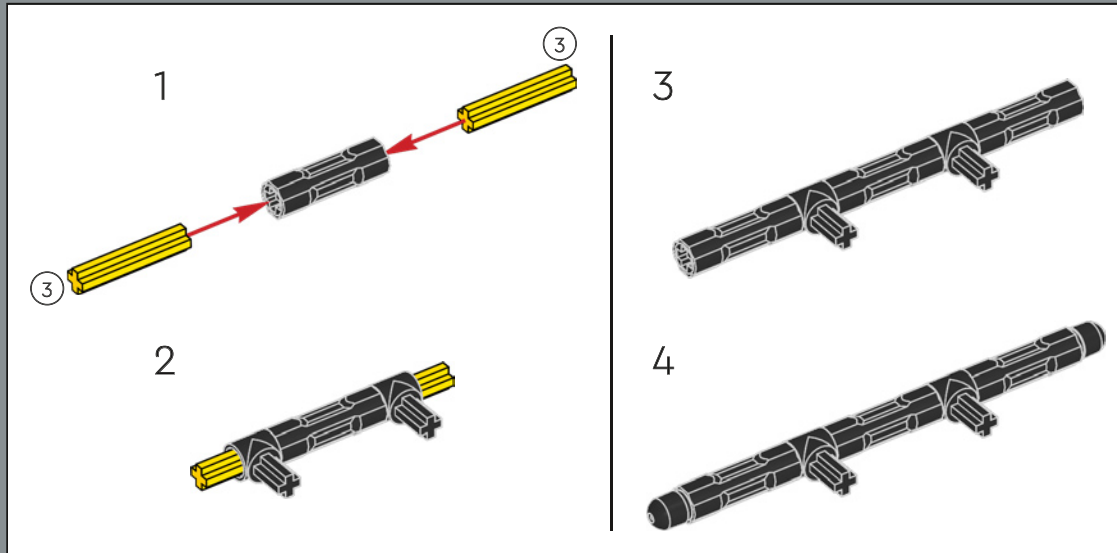

522

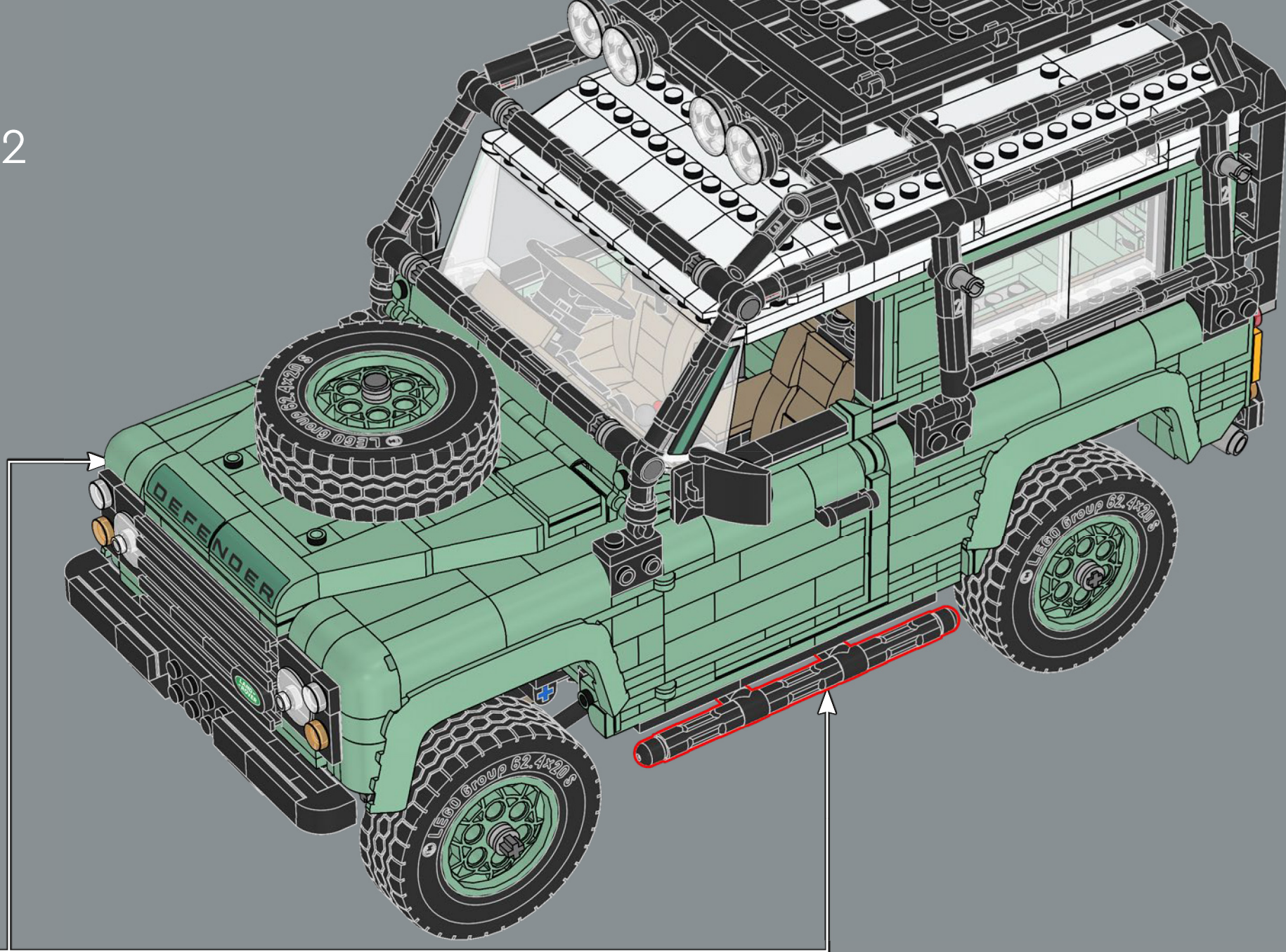

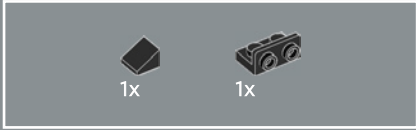
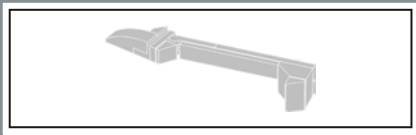

523

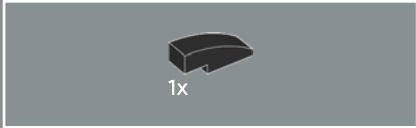
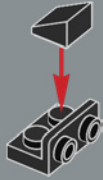

524

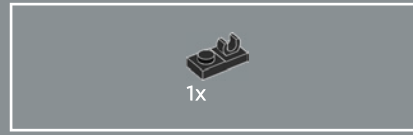
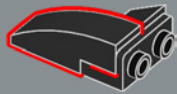

525

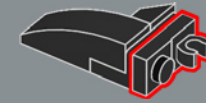

526

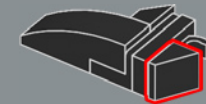

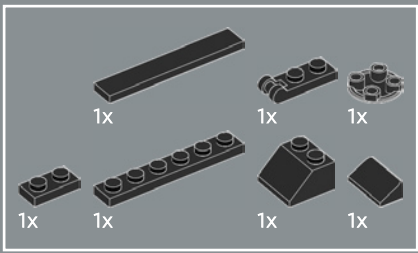

527

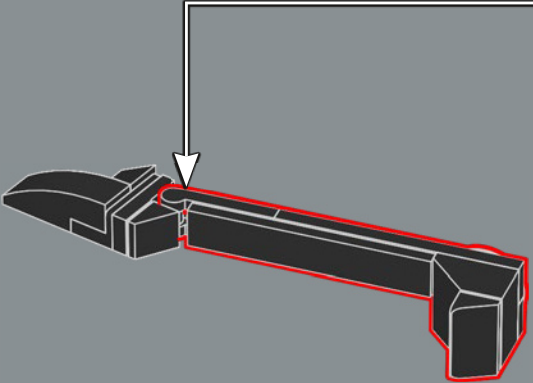
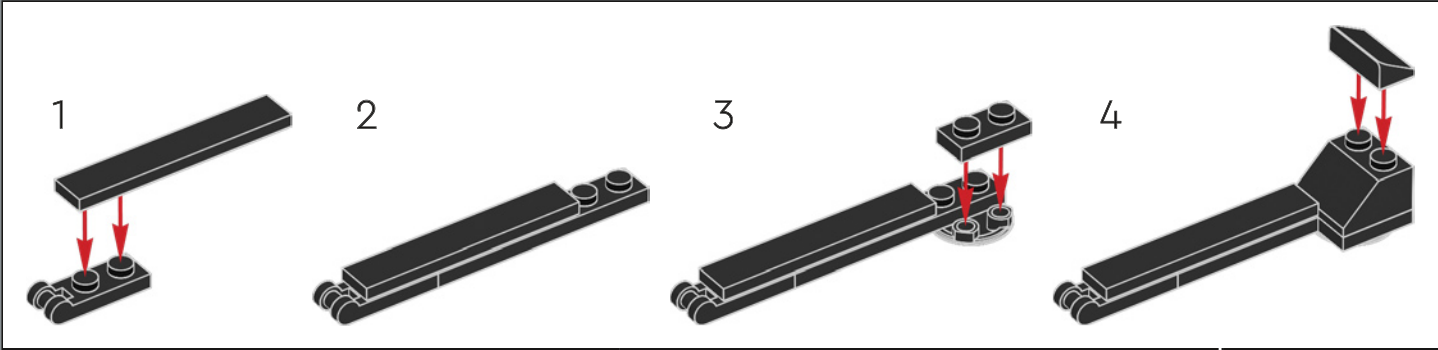

528

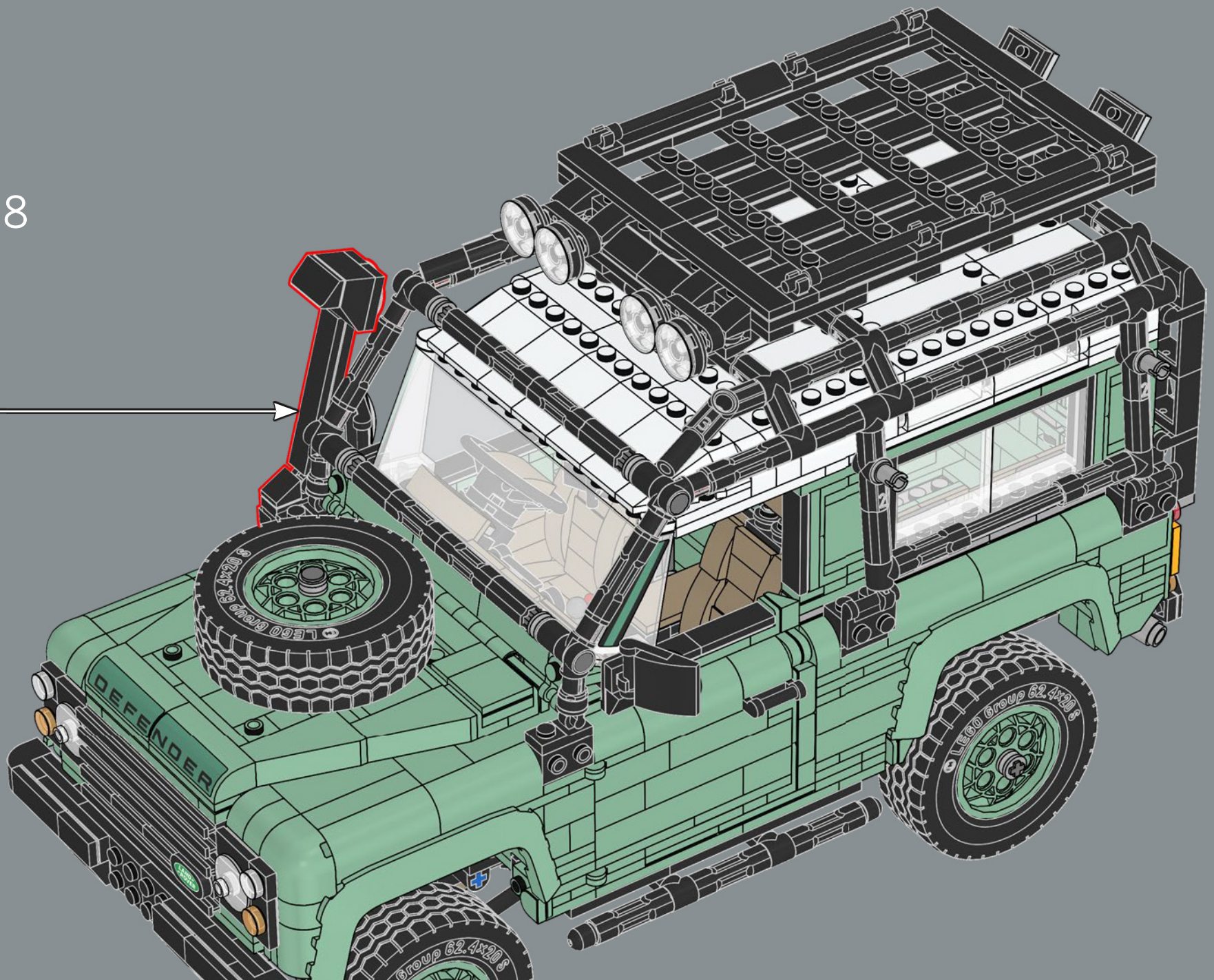



1x

529

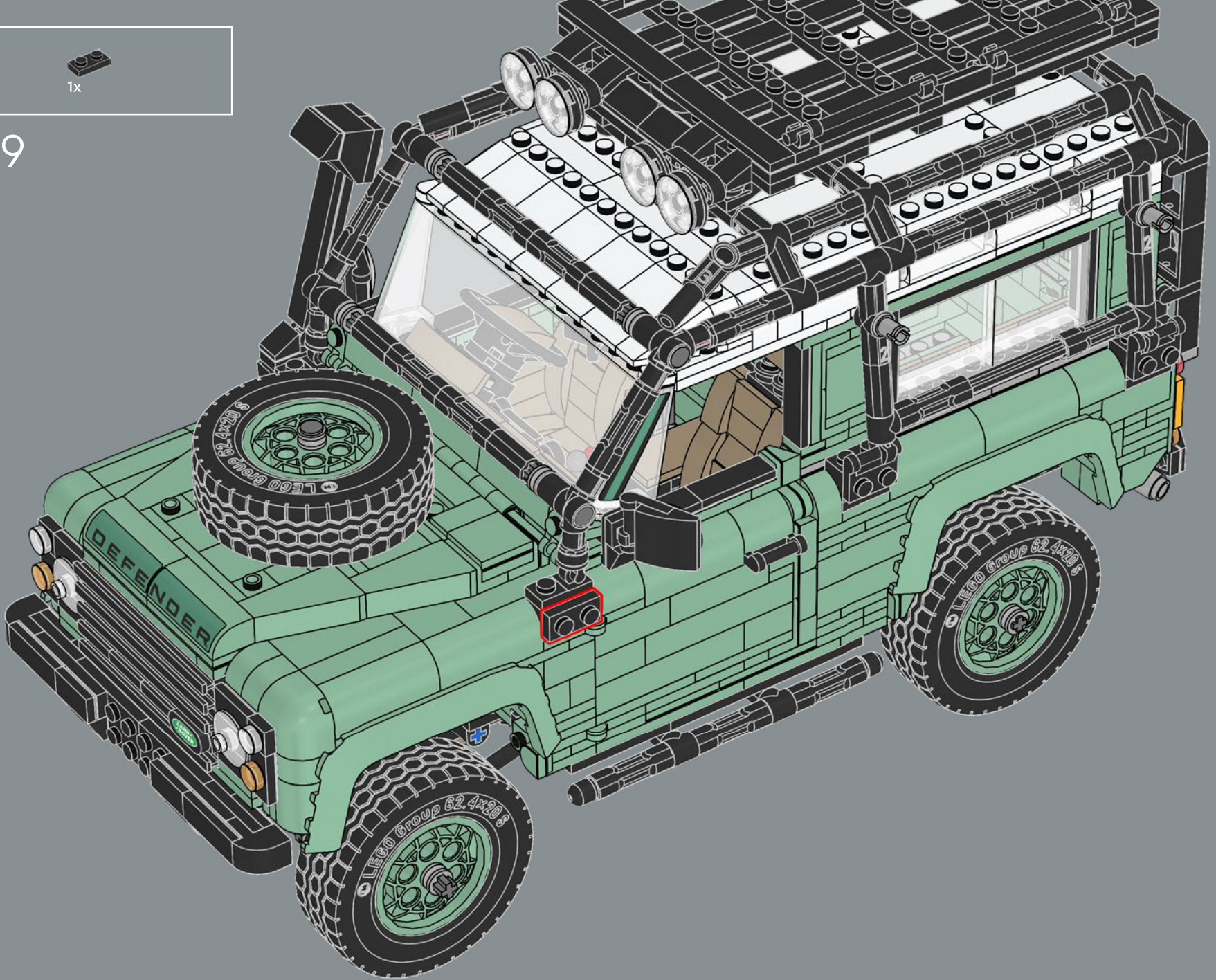

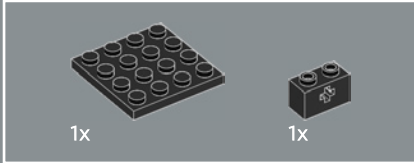
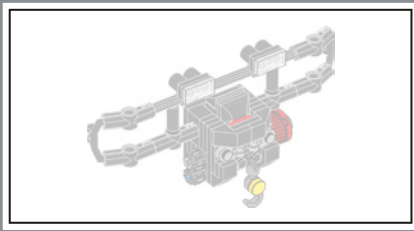

530

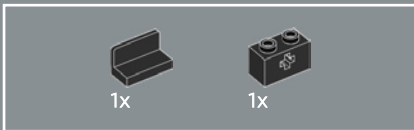
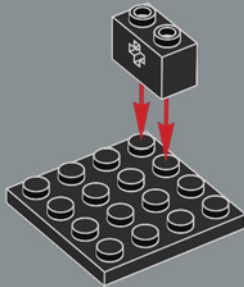

531

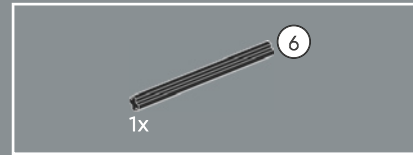
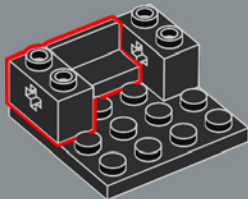

532

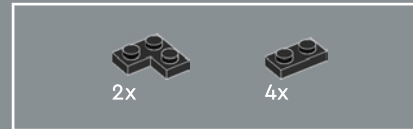
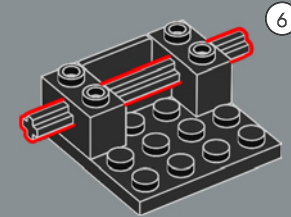

533

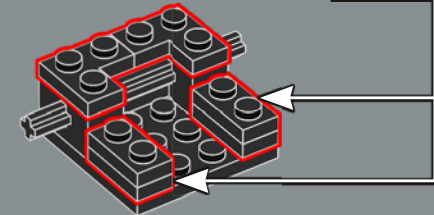
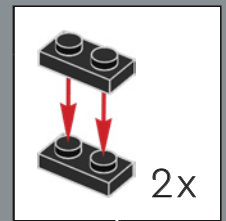

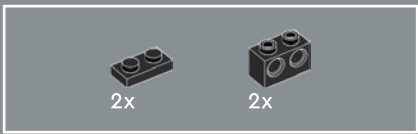

534

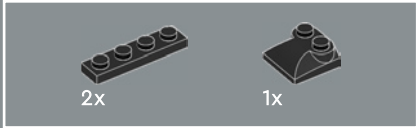
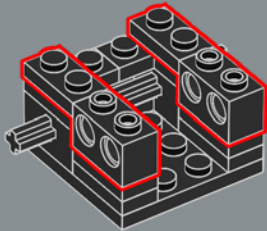

535

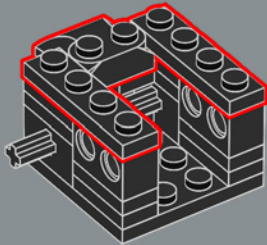

536

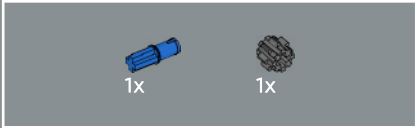
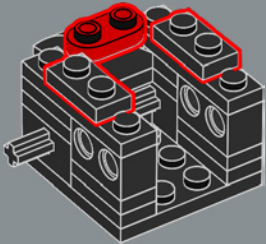

537

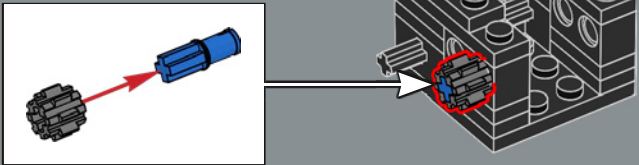

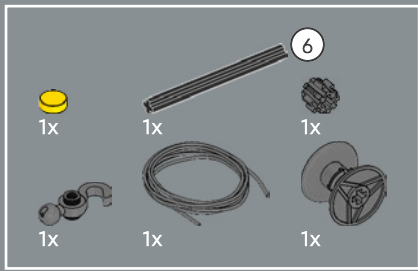

538

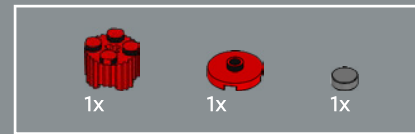
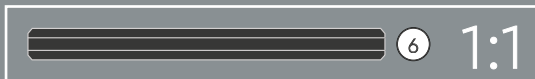
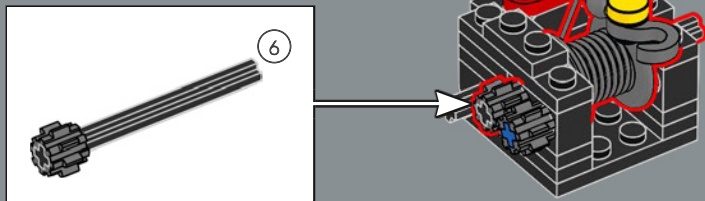
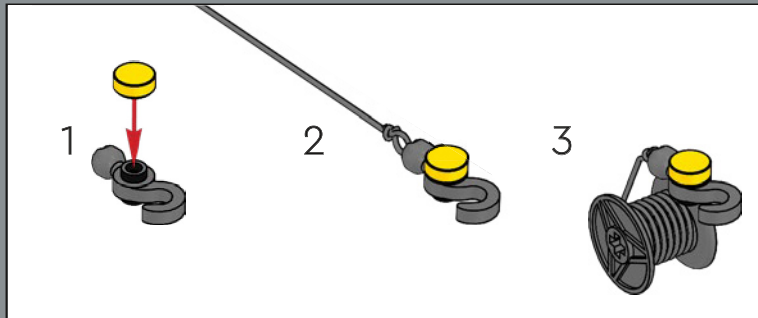

539

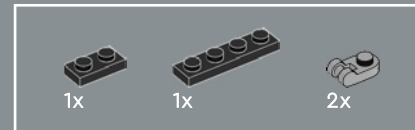
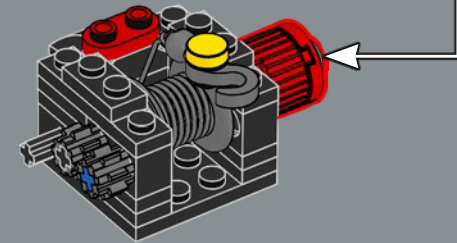
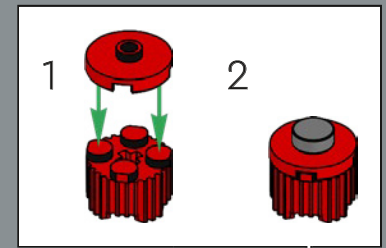

540

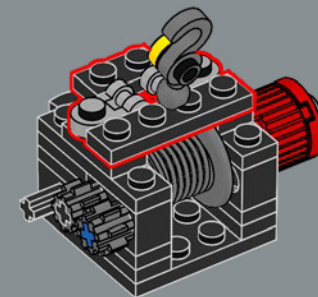



4x

541

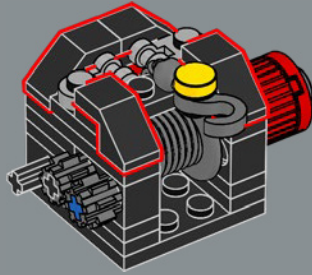

1x



1x

542

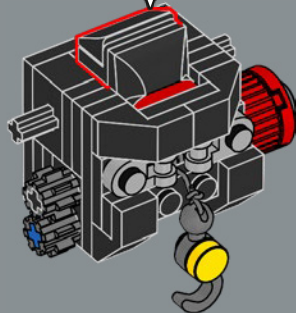
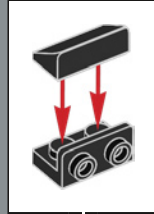

2x



2x



2x



2x

543

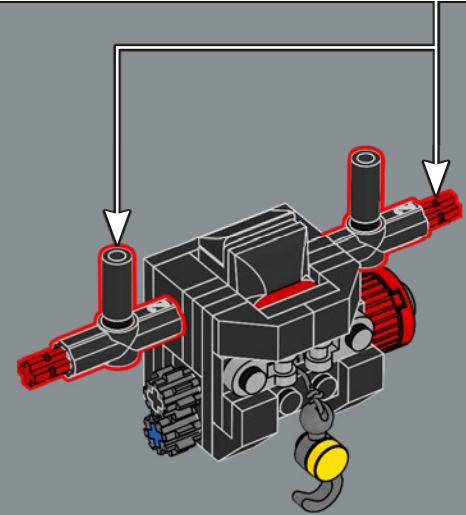
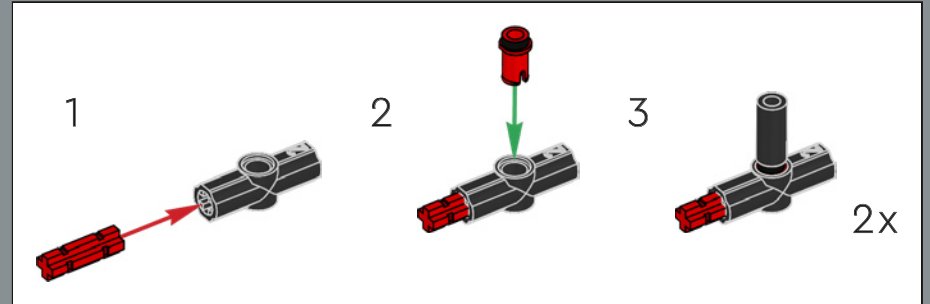

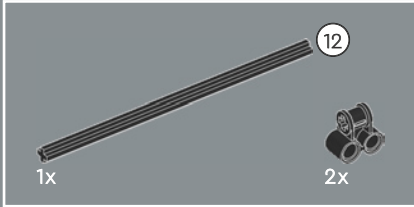
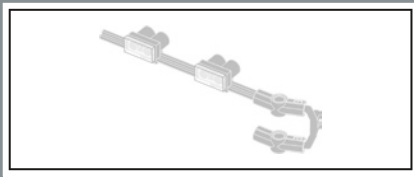

544

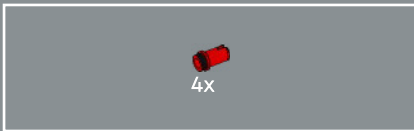

545

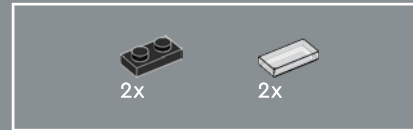
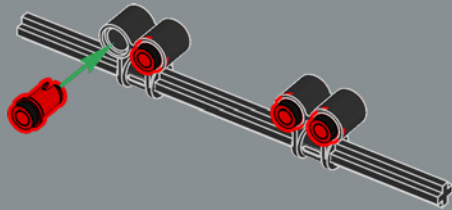

546

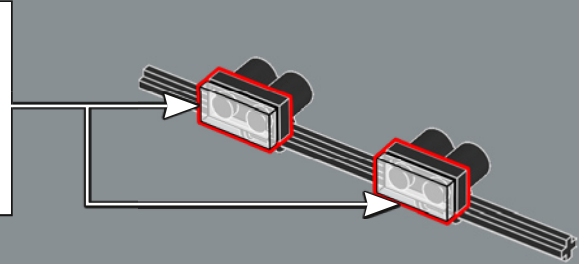
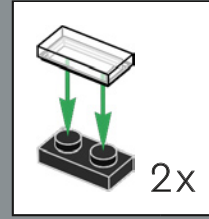

547

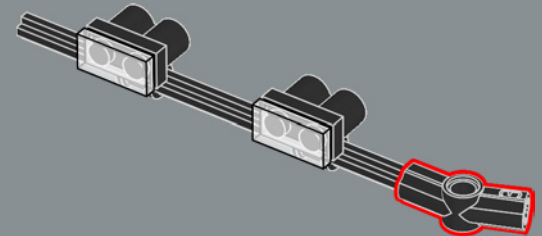



548

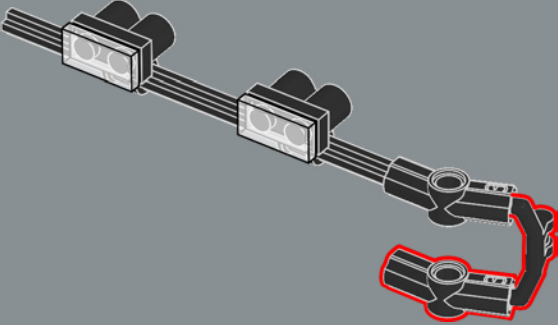

549

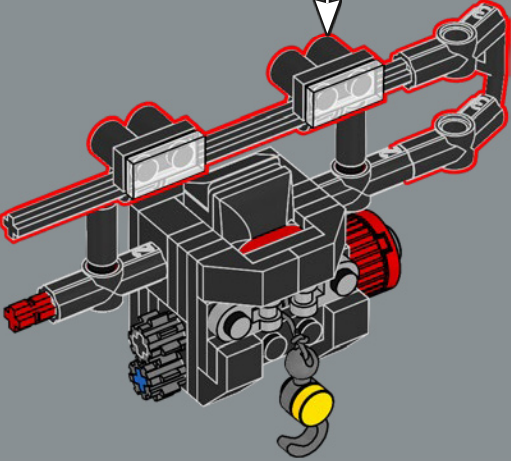

550

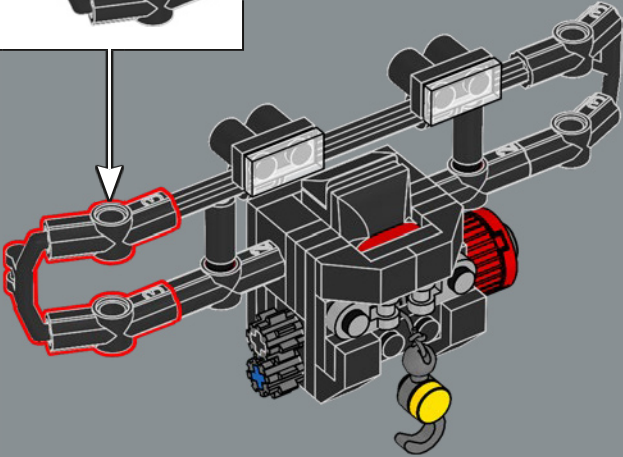
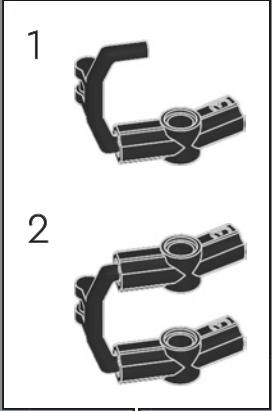

551

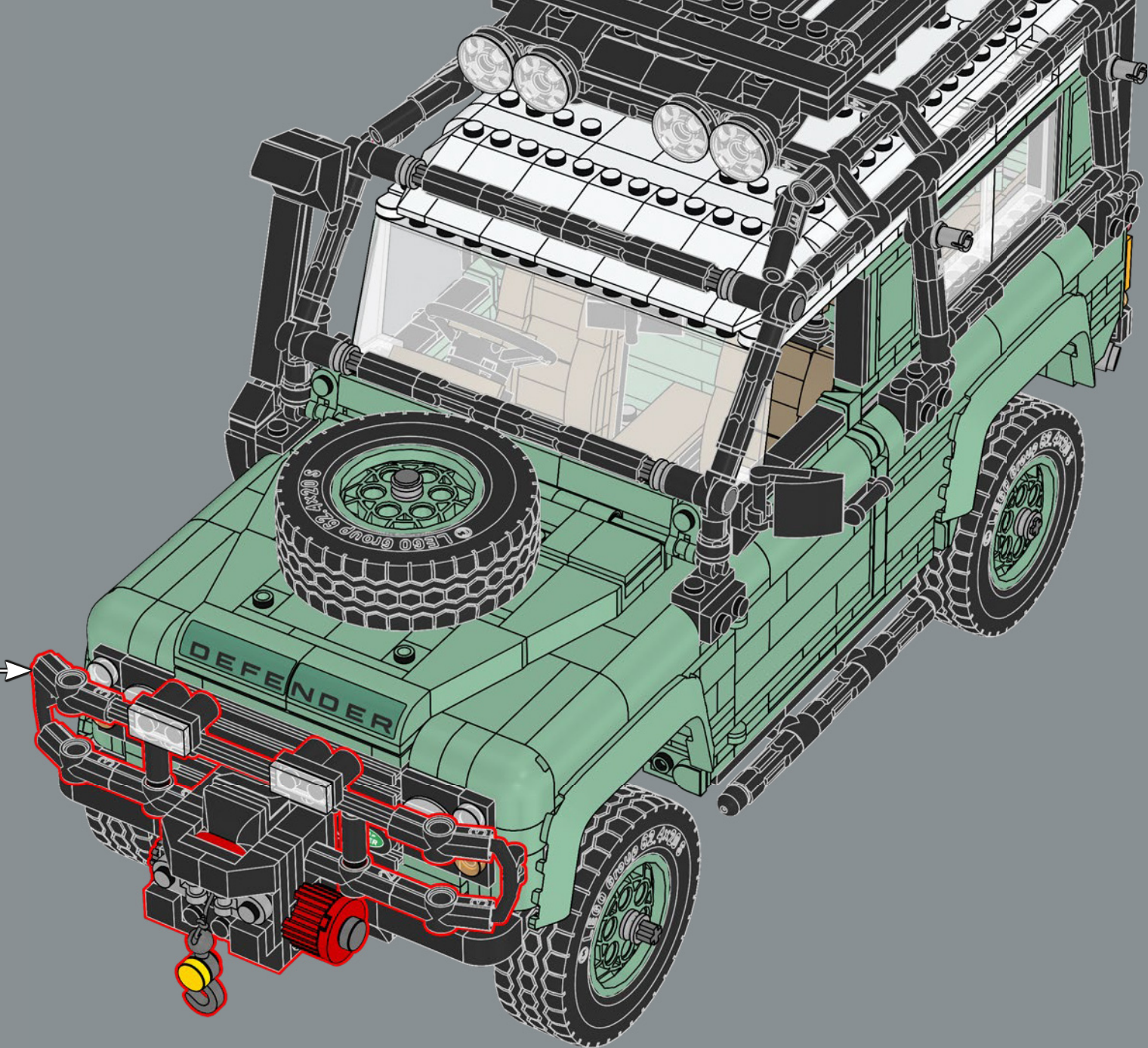



552

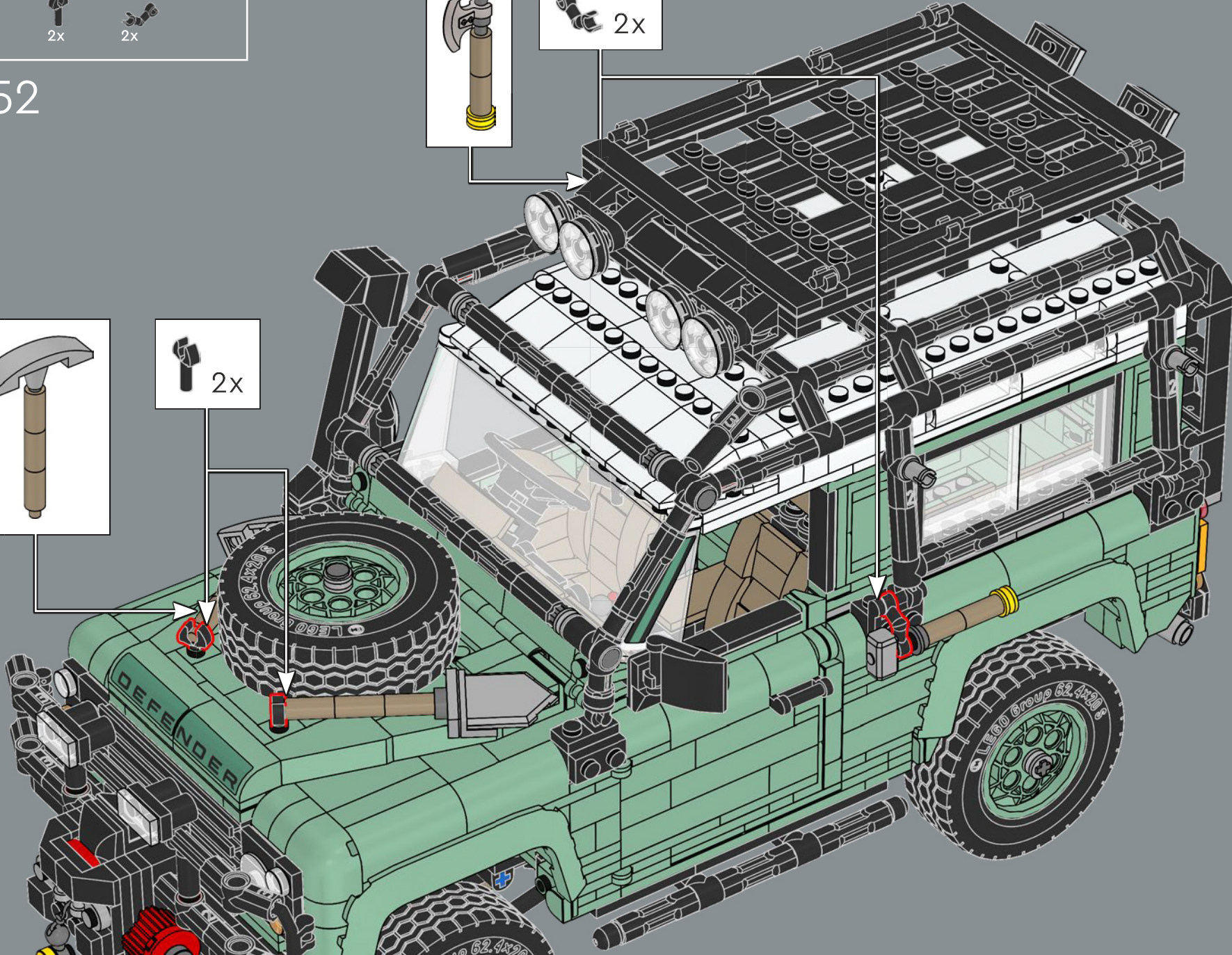
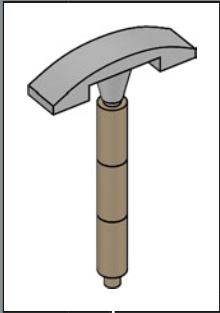
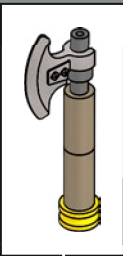



553

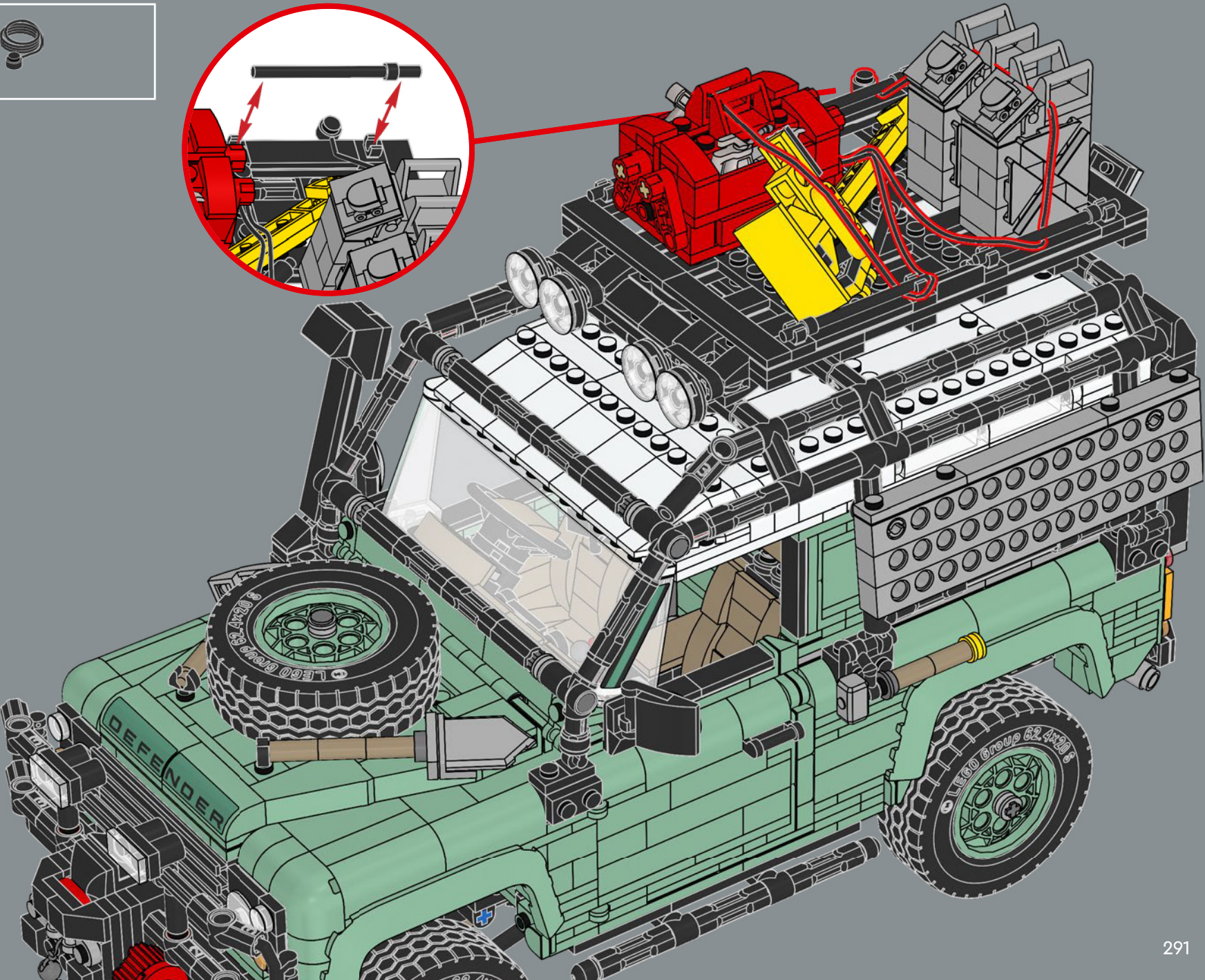
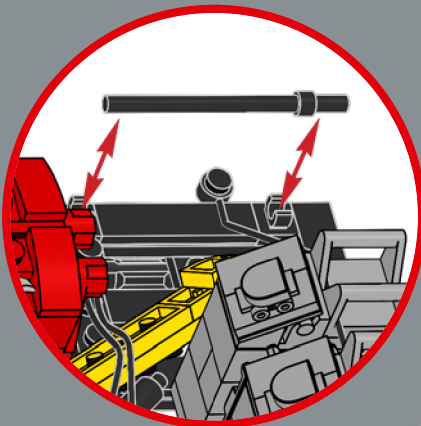

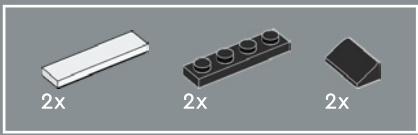

1

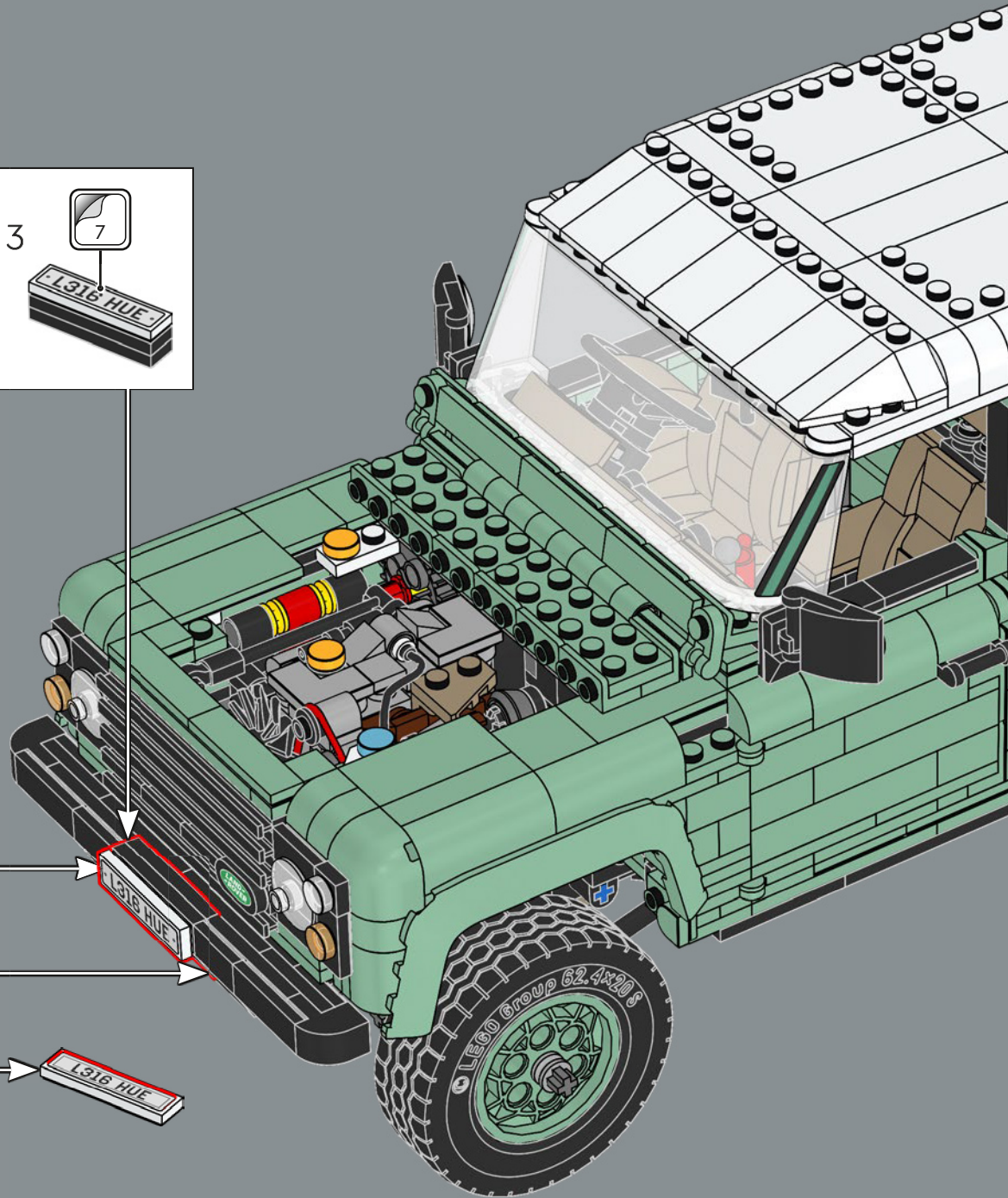
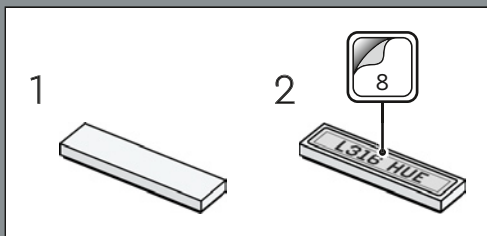
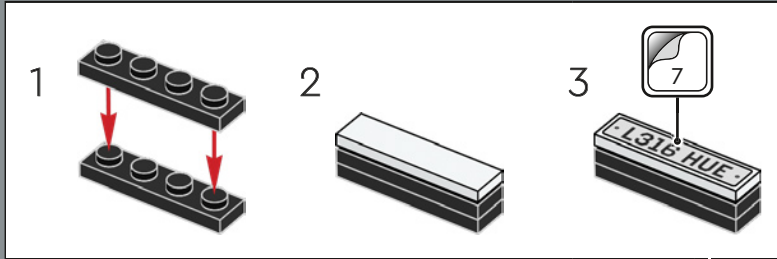

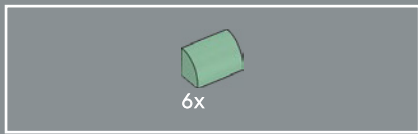

2

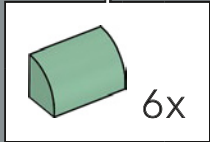
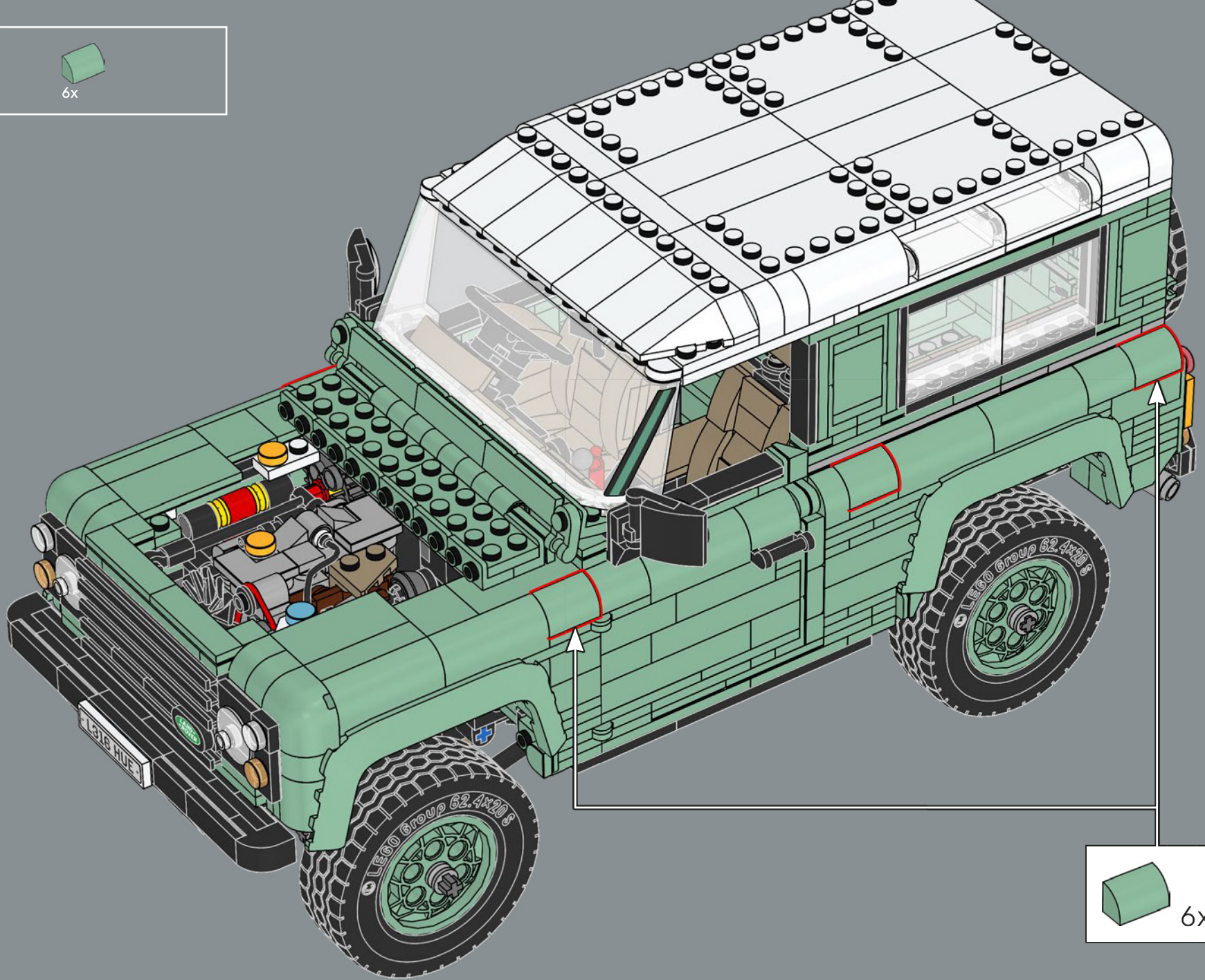

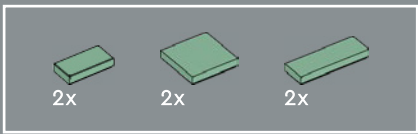

3

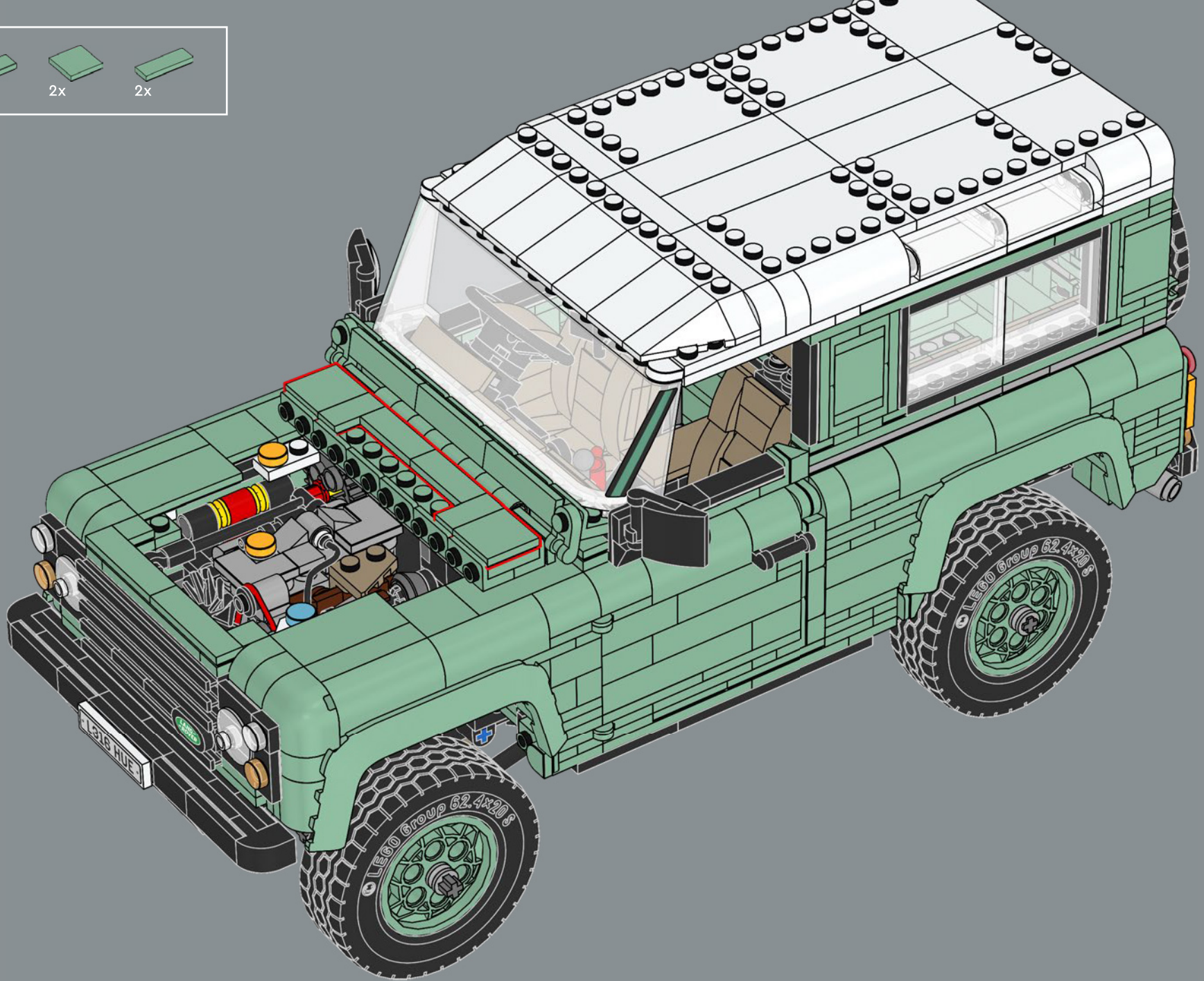

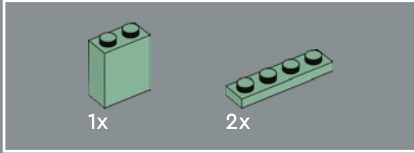
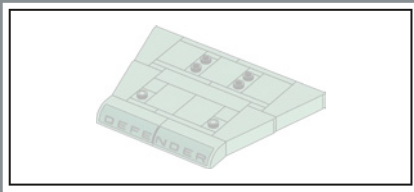

4

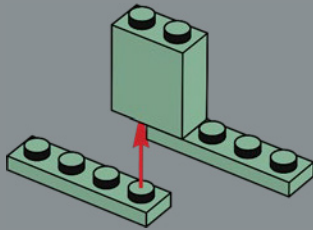

5

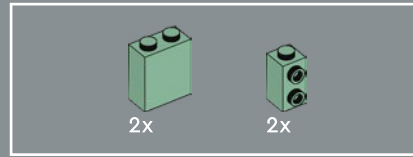
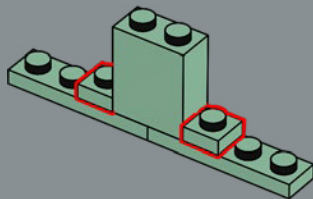

6

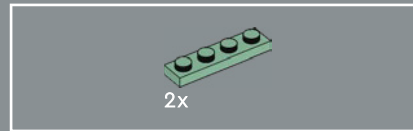
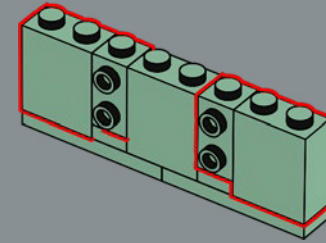

7

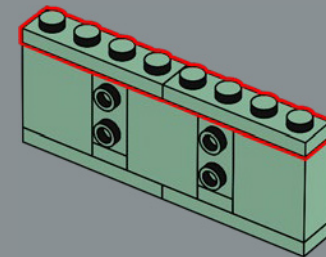

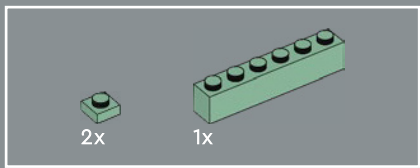

8

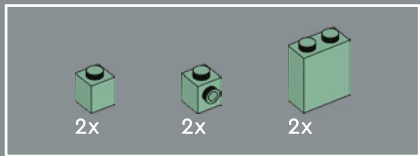
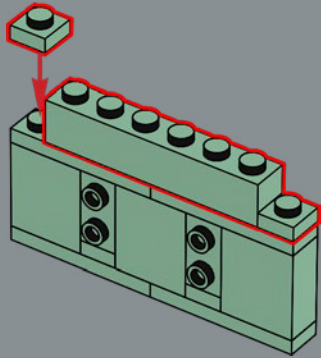

9

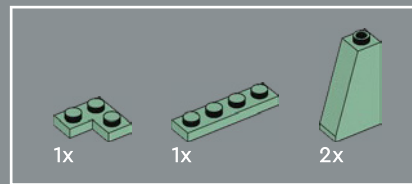
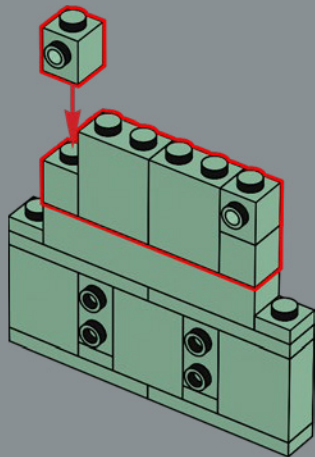

10

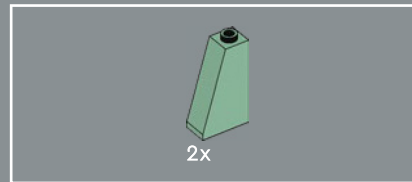
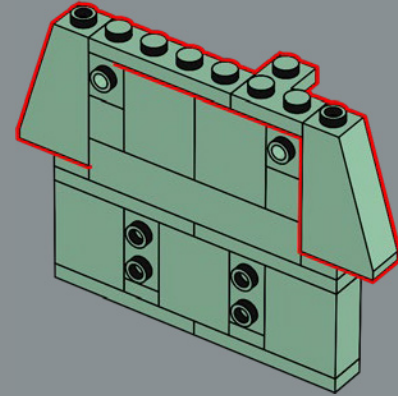

11

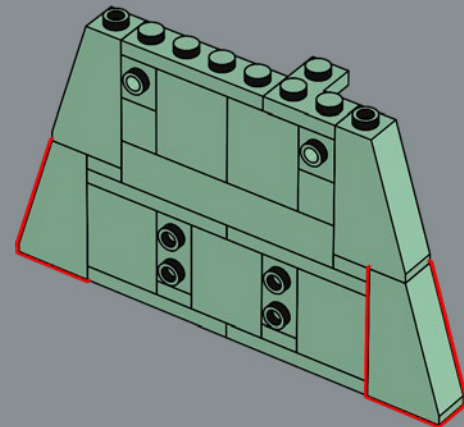

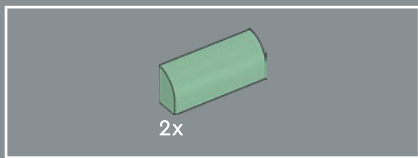

12

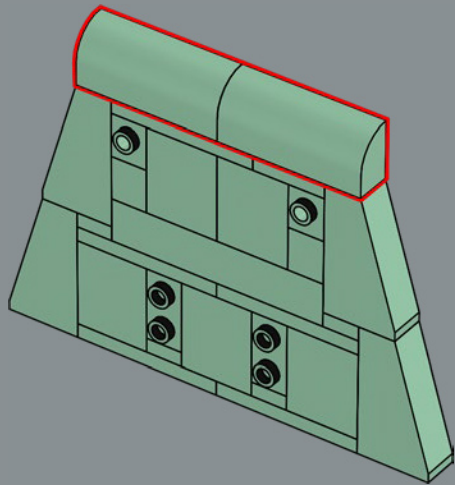

13

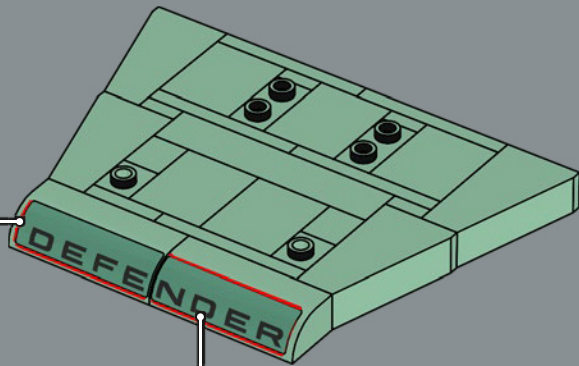

14

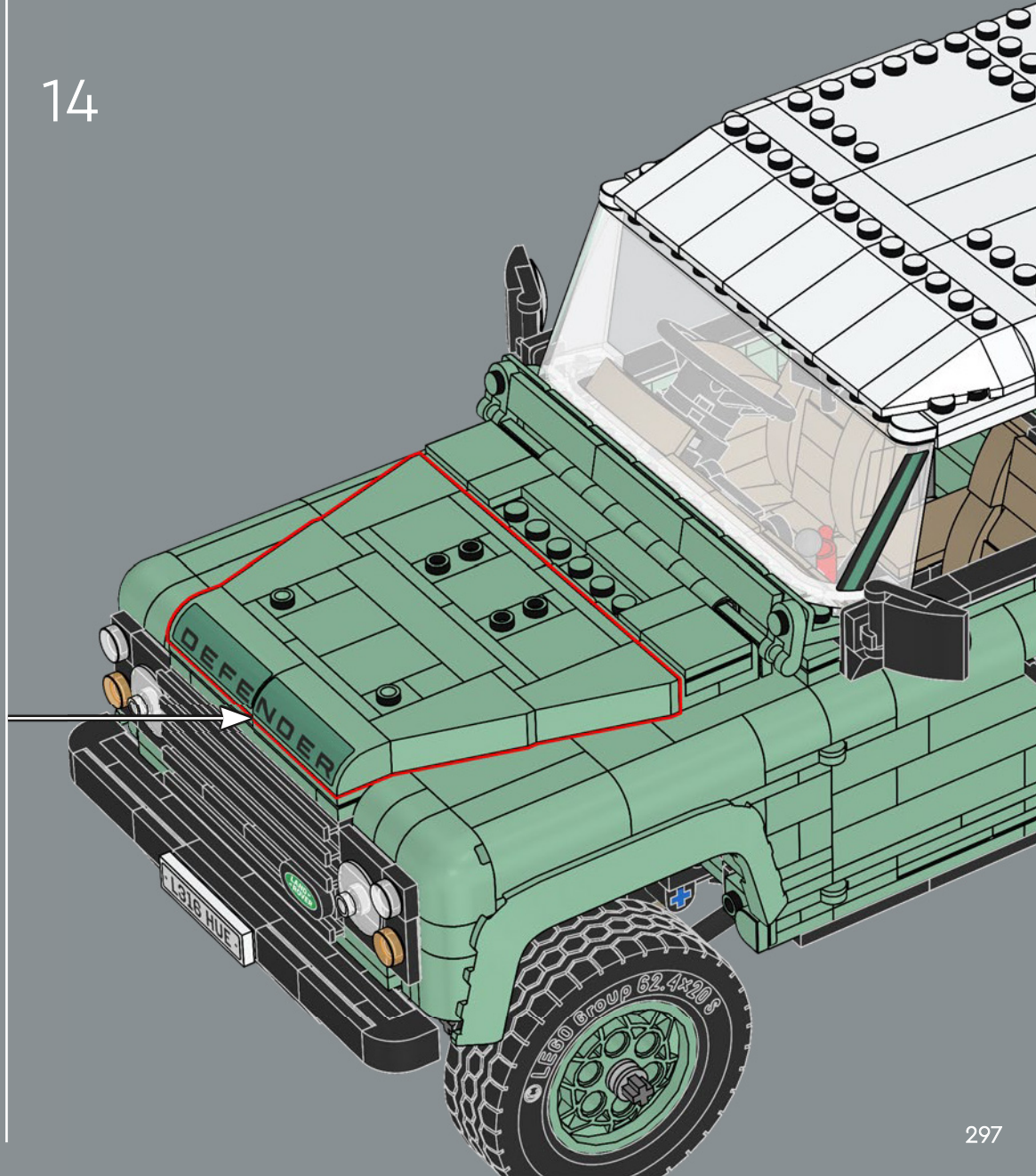

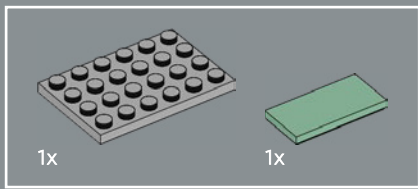

15

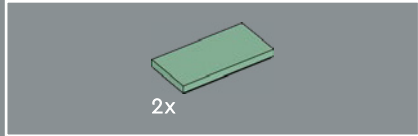
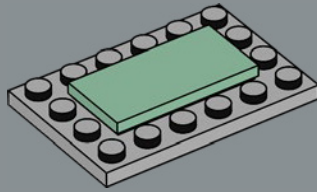

16

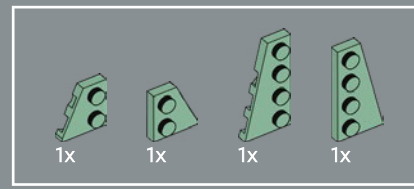
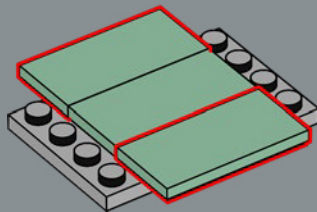

17

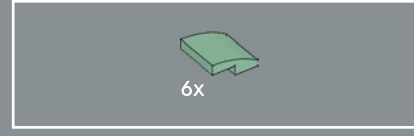
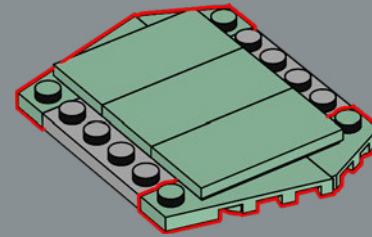

18

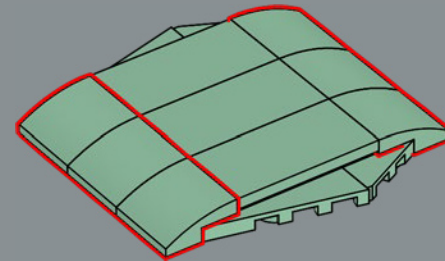

19

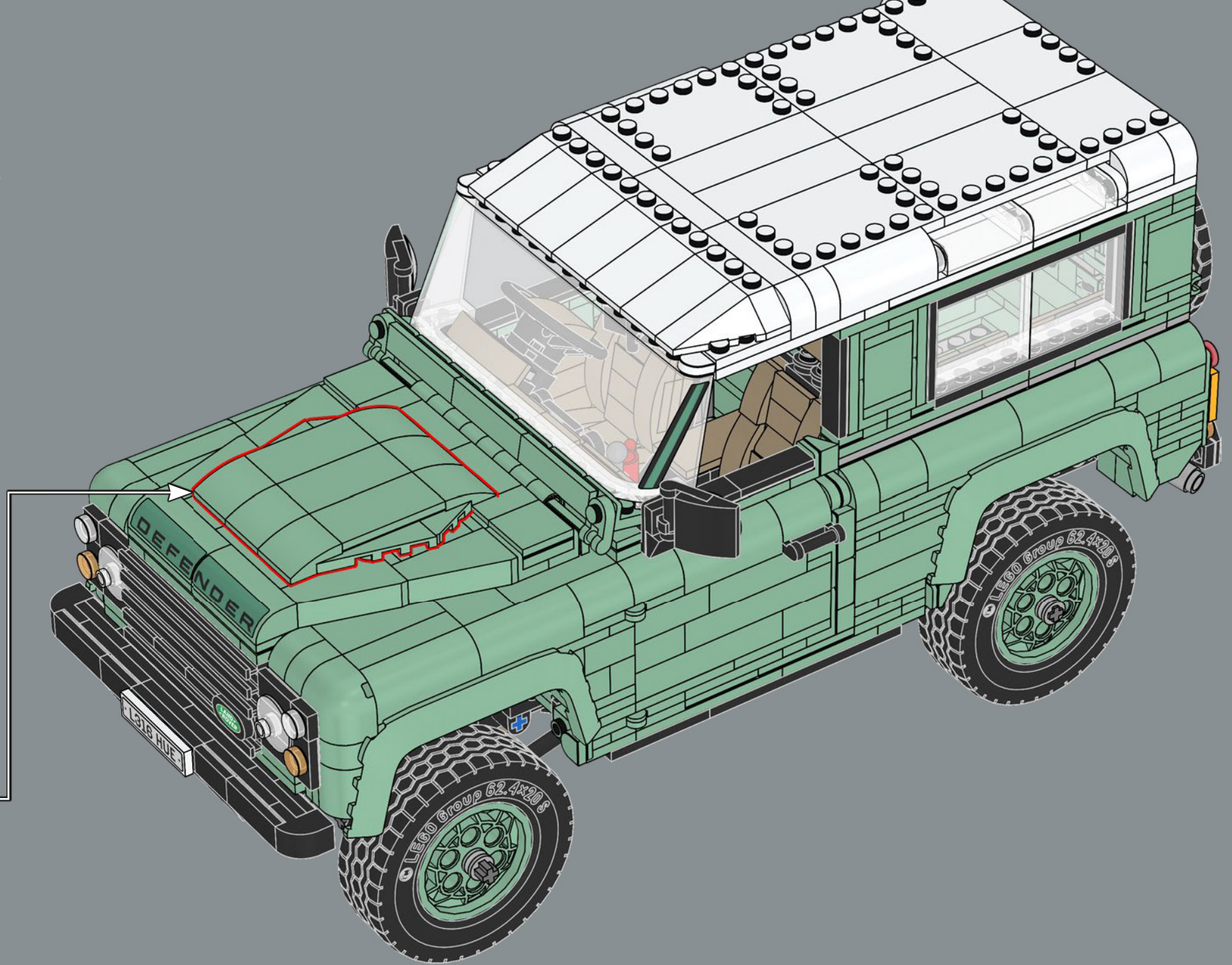



6x



6x

1

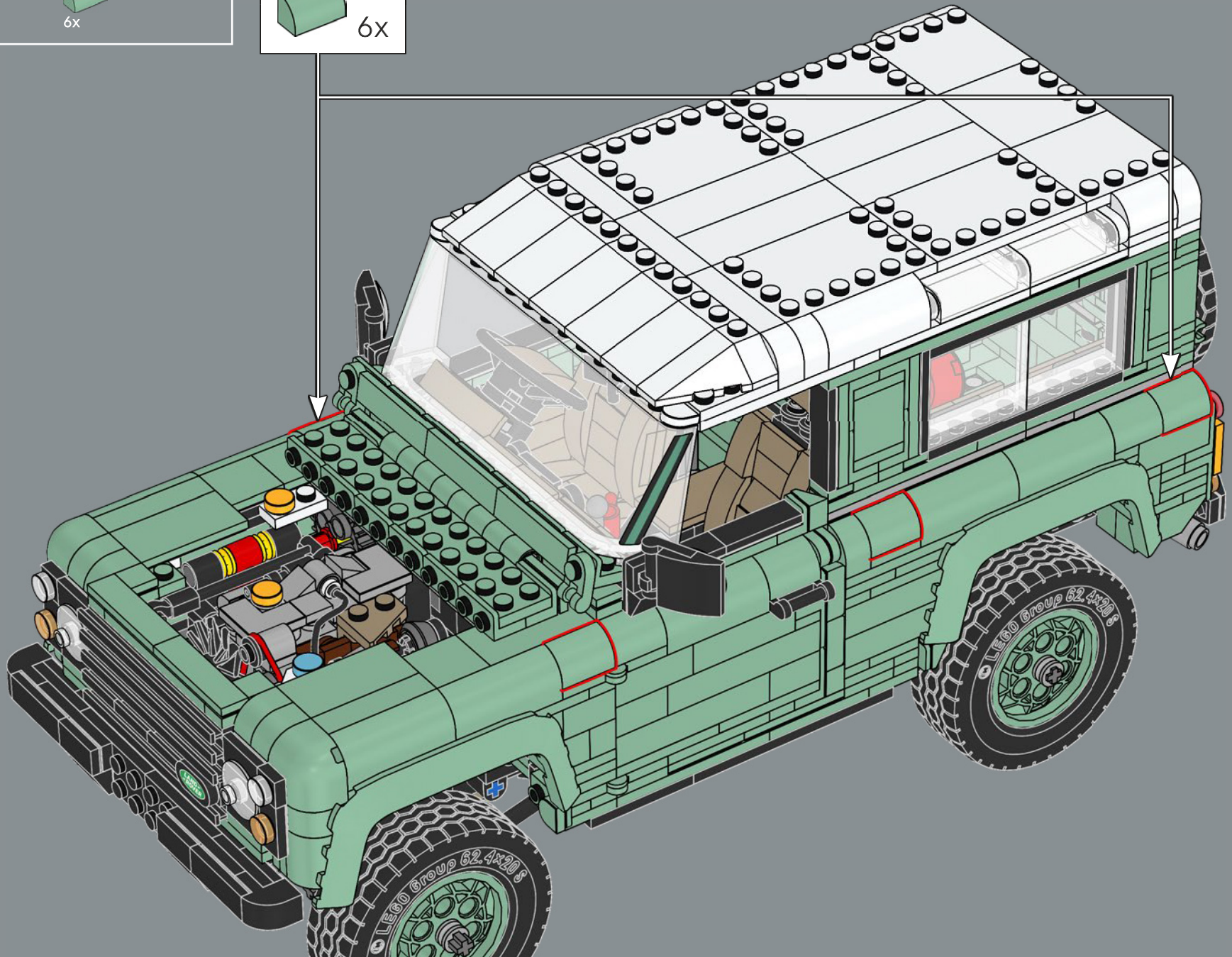

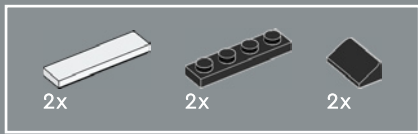

2

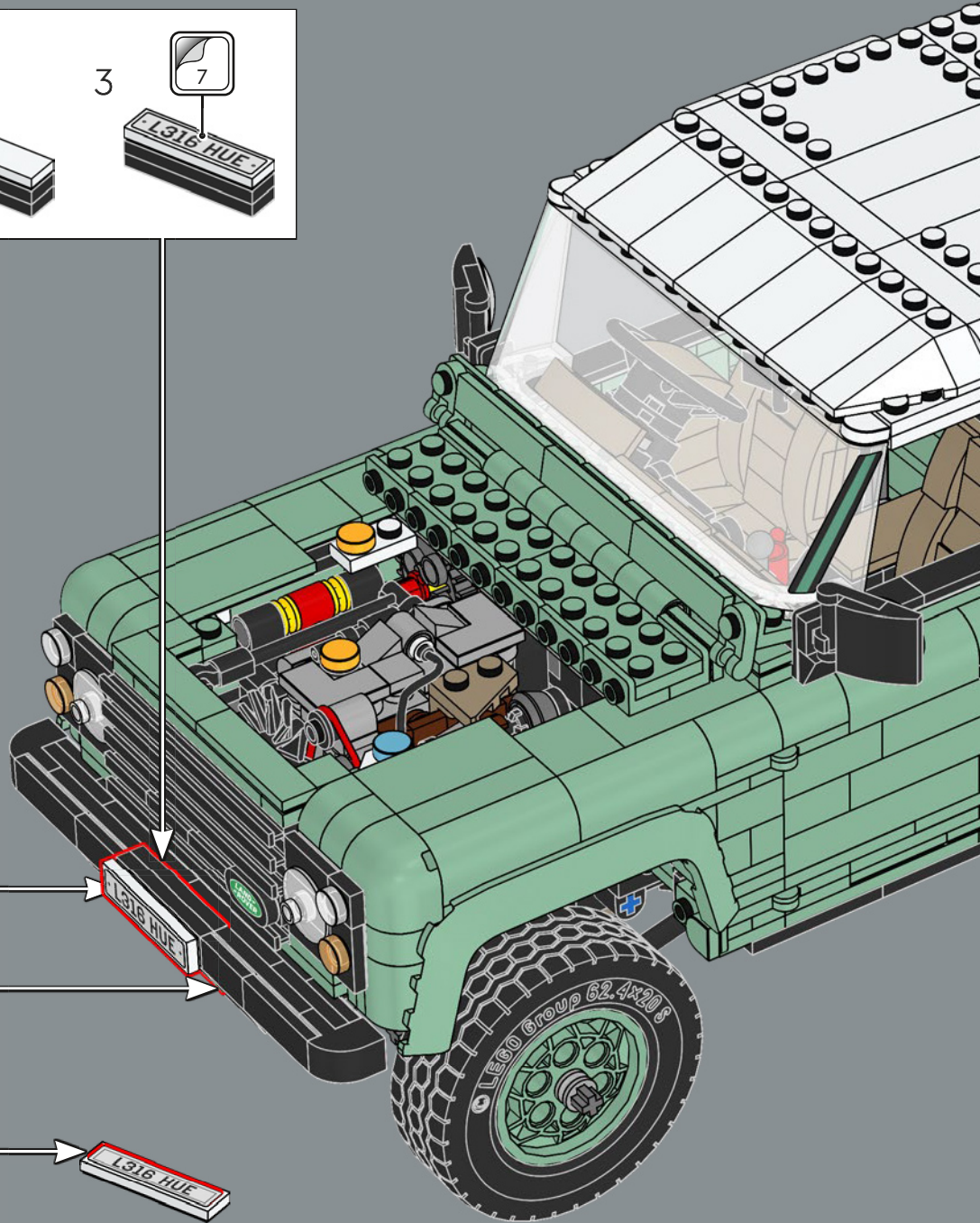
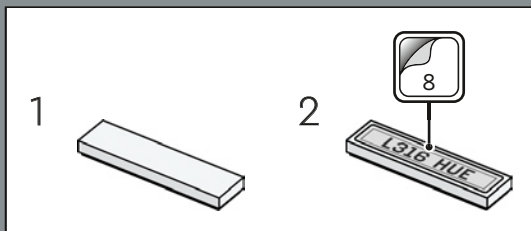
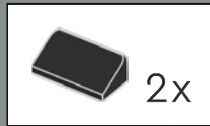
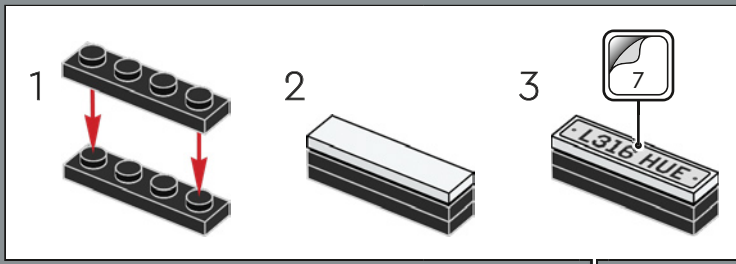

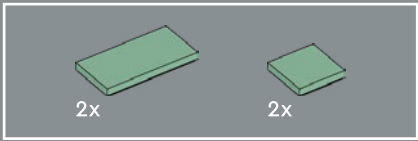

3

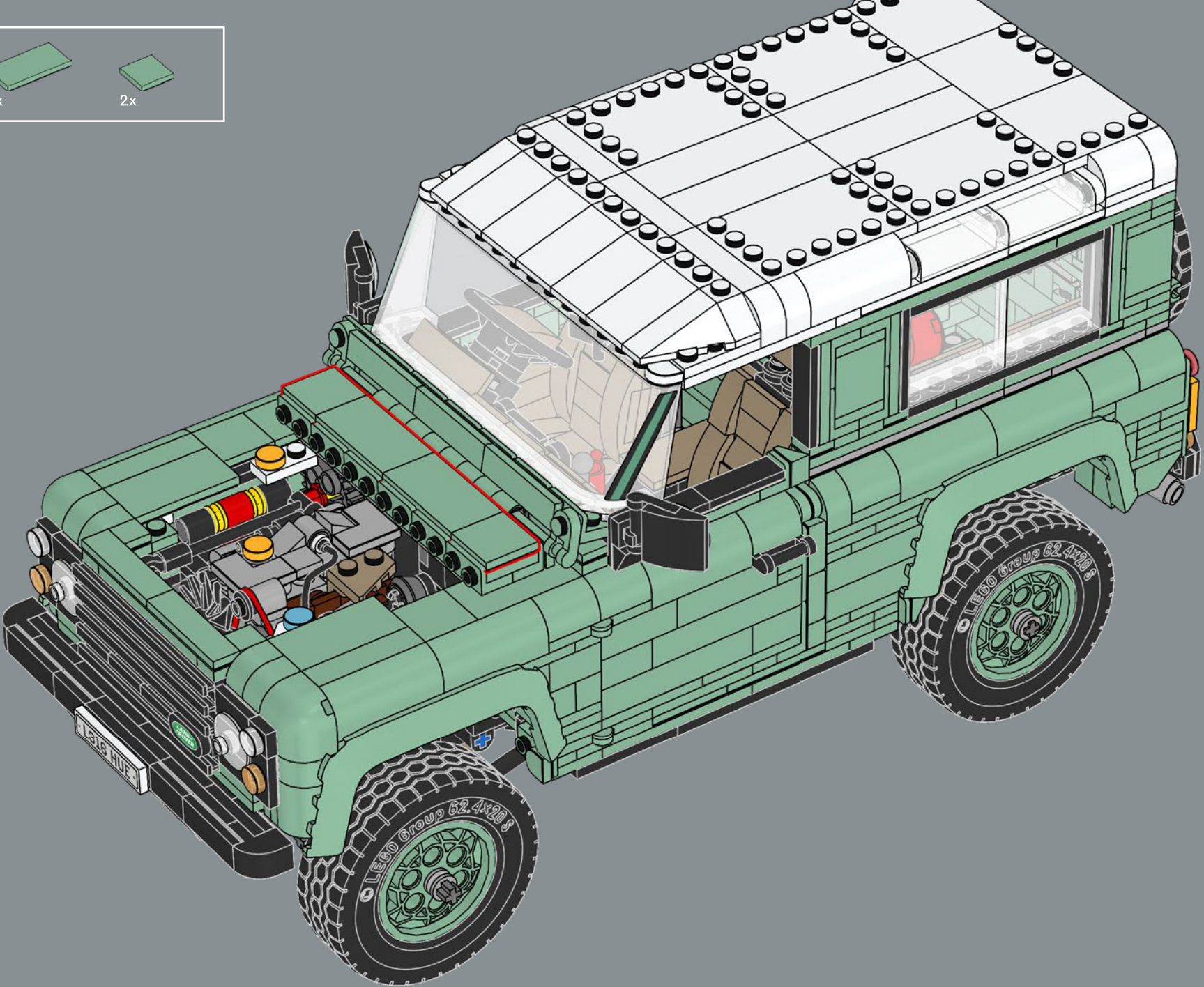

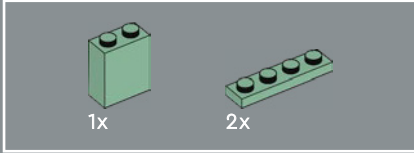
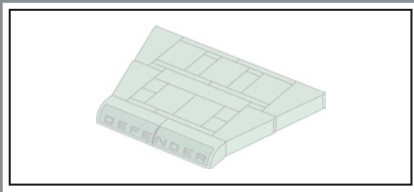

4

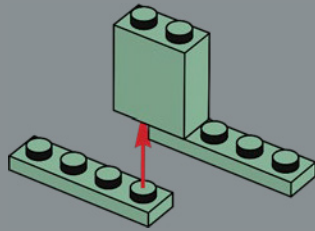

5

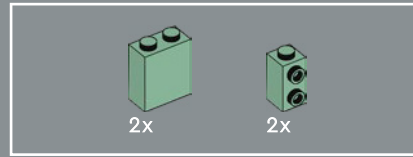
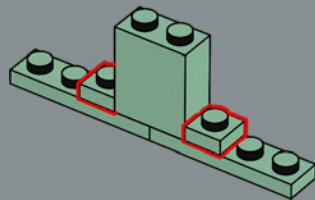

6

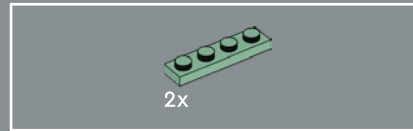
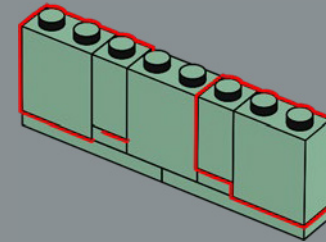

7

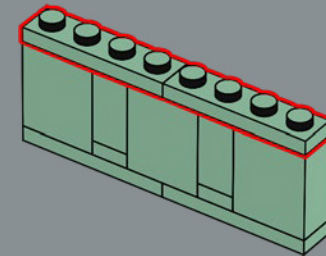

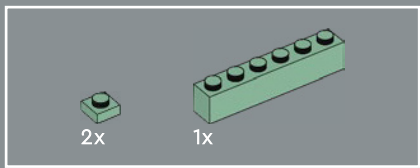

8

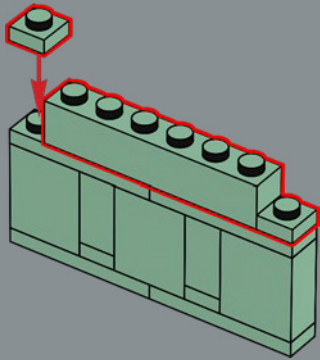

9

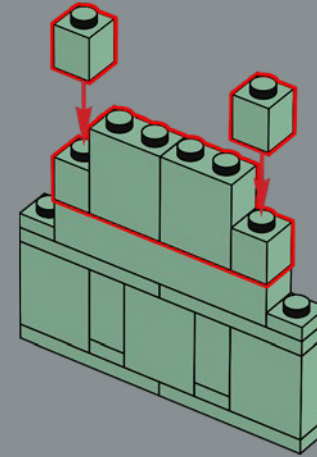

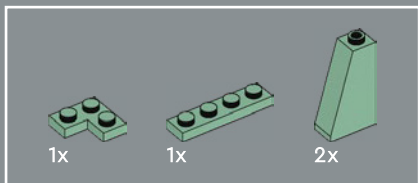

10

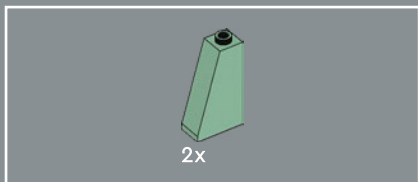
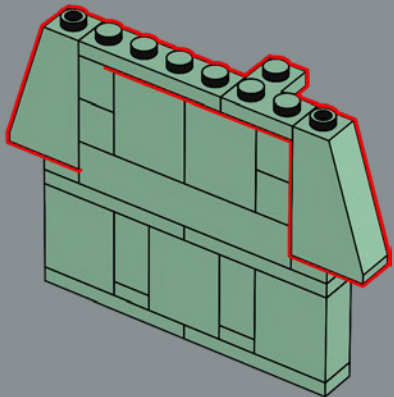

11

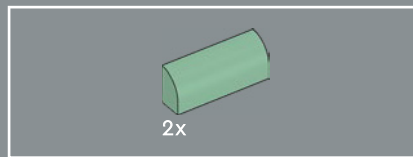
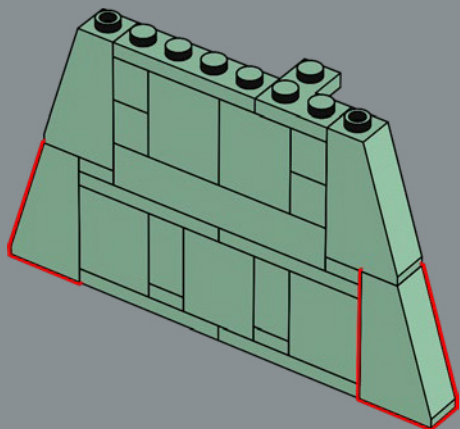

12

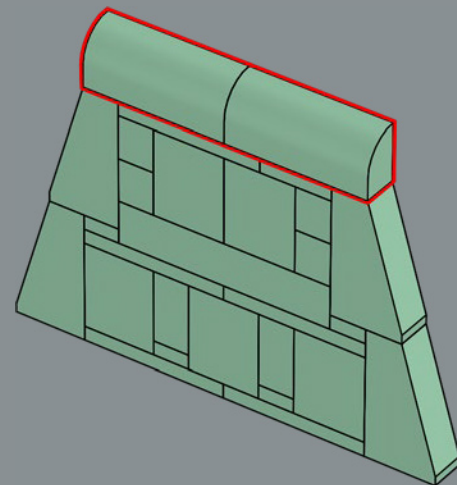

13



4

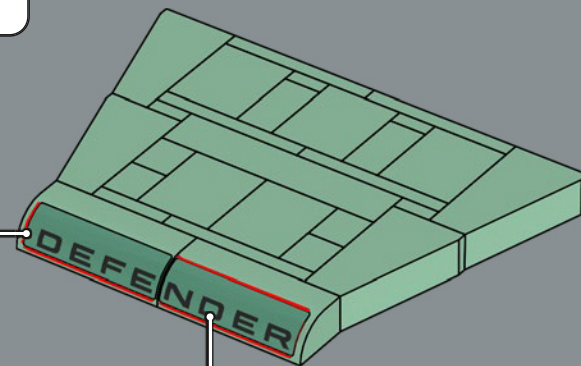

5

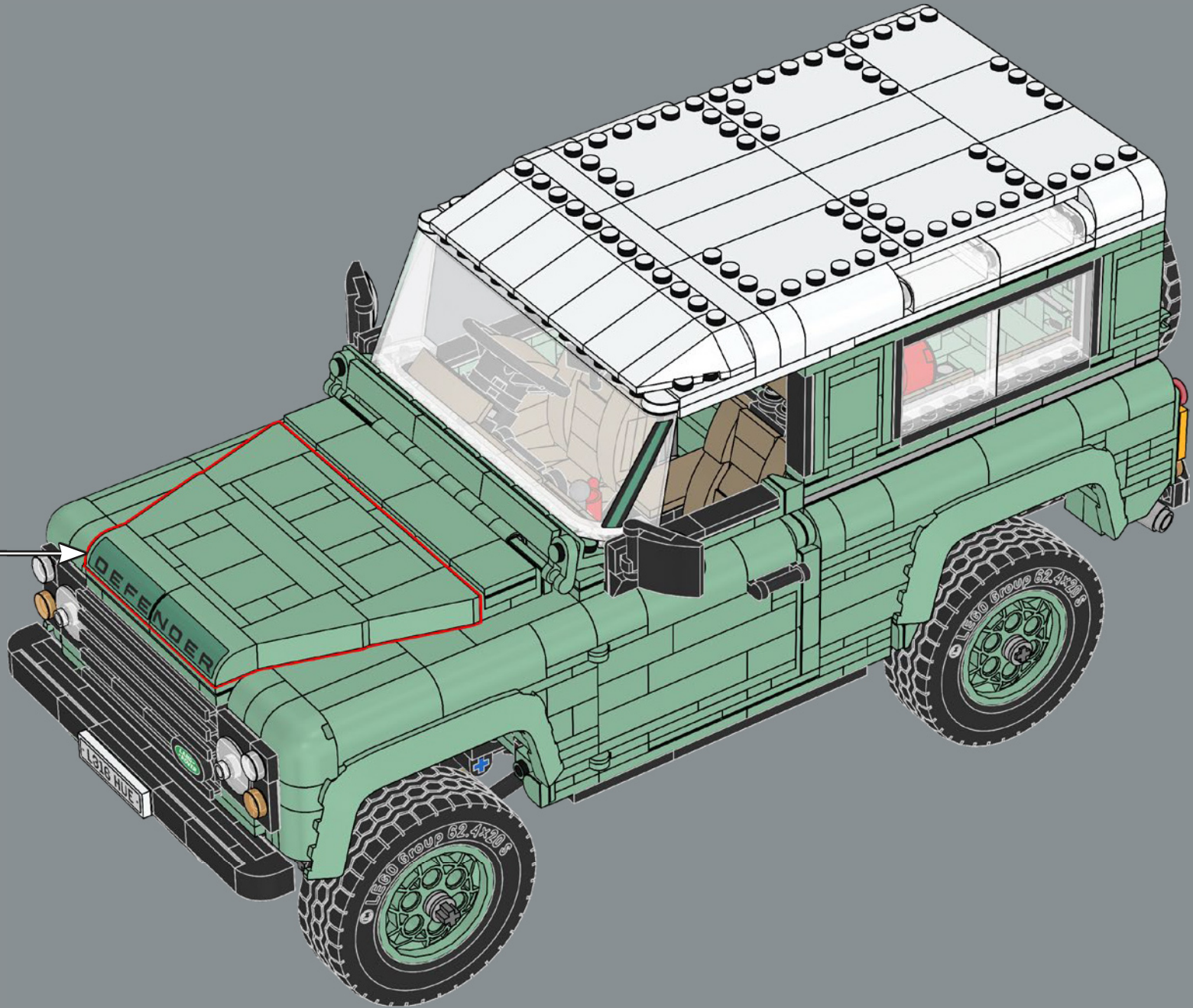

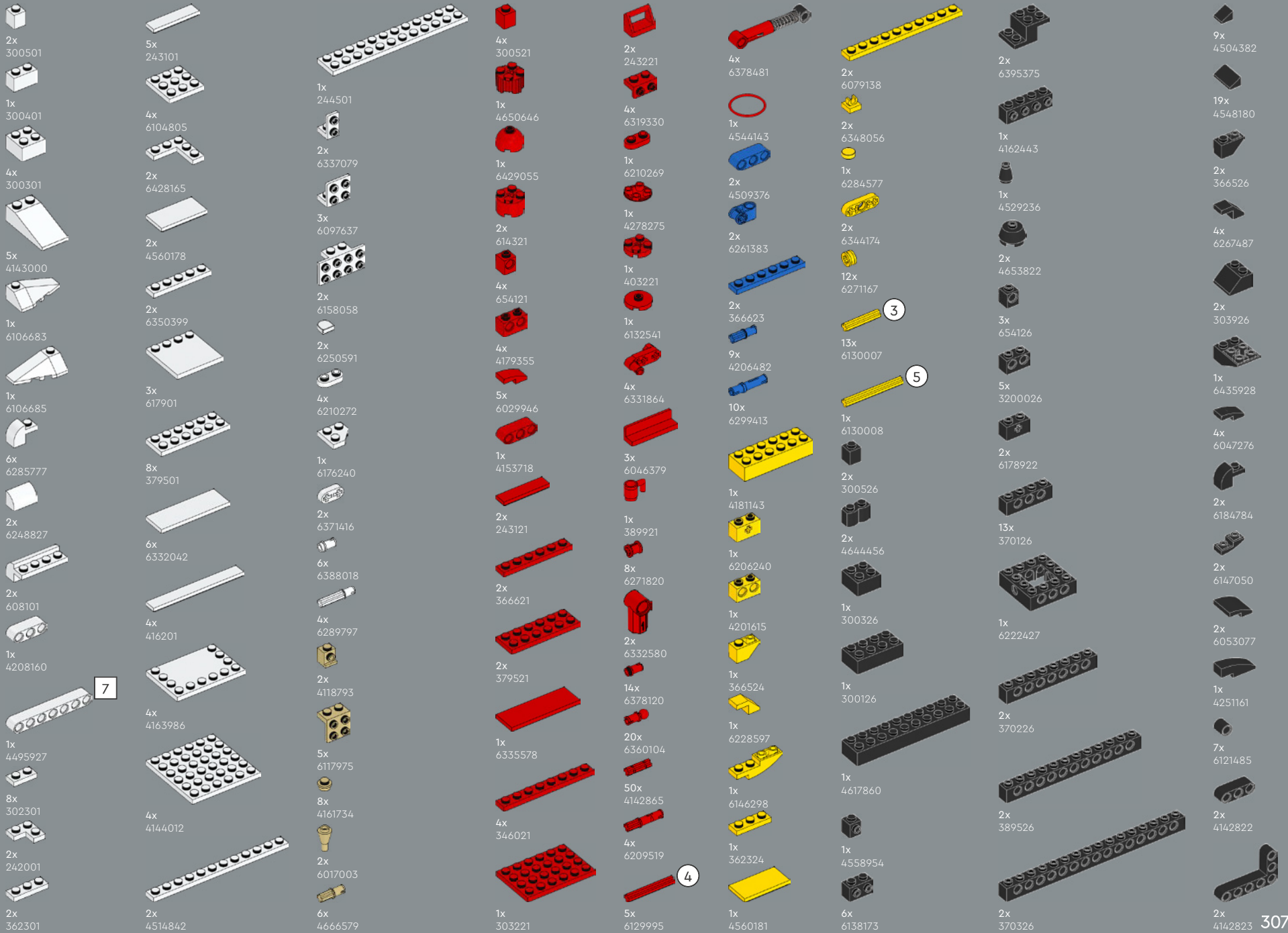

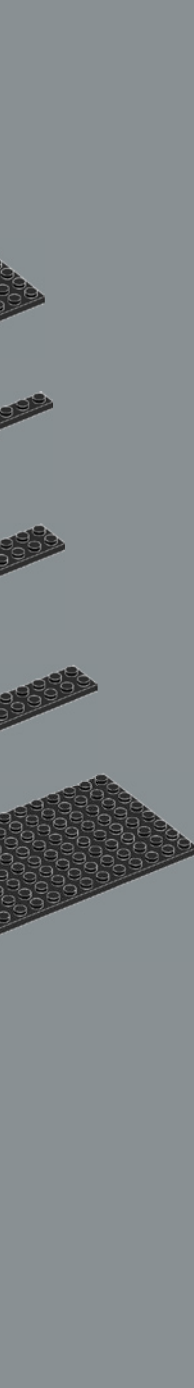





1x
6248078



5x
6227897



3x
6225246



4x
4211357



3x
6225230



5x
6326078



10x
6117967



4x
4654582



5x
6004990

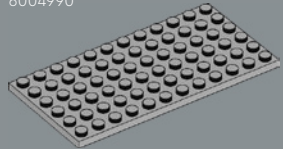

1x
4211400

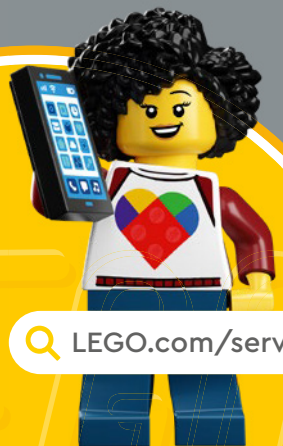

[LEGO.com/service](https://www.LEGO.com/service)



1x
4211568



1x
6284071



5x
6168647



3x
6329581



16x
4211525



3x
6250597



6x
6248890



2x
6360043



1x
4221775



2x
6217791



1x
6004729



1x
6326748



1x
6245254



10x
6271165



2x
6378136



1x
6167667



2x
4211375



9x
4211807



1x
6335279



2x
6338962



2x
6265690



2x
4211469



2x
4211881



2x
4640536



1x
6322819



2x
6362259



14x
6178919



3x
4211111



2x
4211133



9x
4211043



7x
6271752



1x
6413106



6x
4521187



6x
6364452



4x
6327561



2x
4211001



18x
6083620



2x
4508553



1x
4499858



3x
4210997



6x
6133611



4x
4211067



1x
6284596



3x
6231765



1x
6236395



4x
6308045



1x
6396058



8x
6000606



2x
6349479



4x
6278260



1x
6350724



1x
6340333



2x
6359227



1x
6347464



1x
6364352



15x
6015356



2x
4610374



1x
4239891



1x
6317653



6x
4629920



4x
6012451



2x
6133119



1x
6430214



1x
6317181



1x
6103444



1x
6363145



1x
6363145



YOU COULD WIN



YOU COULD WIN

Your feedback will help shape the future development of this product series.

Visit:

DU KÖNNTEST GEWINNEN

Dein Feedback trägt zur Weiterentwicklung dieser Produktreihe bei.

Geh auf:

VOUS POURRIEZ GAGNER

Vos commentaires nous aideront à concevoir les futurs produits de cette gamme.

Visitez :

POTRESTI VINCERE TU

La tua opinione ci aiuterà a migliorare la creazione futura di questa linea di prodotti.

Visita:

PUEDES GANAR

Tu opinión contribuirá al futuro de esta serie de productos.

Visita:

轻松获奖

您的反馈将有助于我们在今后改进本产品系列。

请访问:

LEGO.com/productfeedback

You also have the chance to win a LEGO® set.

Terms and conditions apply.*

Außerdem hast du die Chance, ein LEGO® Set zu gewinnen.

Es gelten die Teilnahmebedingungen.*

Vous pourriez également gagner un ensemble LEGO®.

Des conditions s'appliquent.*

Hai anche la possibilità di vincere un set LEGO®.

Termini e condizioni sono applicabili.*

También tienes la oportunidad de ganar un set LEGO®.

Aplican términos y condiciones.*

您还有机会赢取乐高®套装。

条款和条件适用。*

*LEGO.com/productfeedback-terms

