



21061





LEGO.com/sustainable-packaging



FR  
**DONNEZ**  
OU  
**RECYCLEZ**



ASSOCIATION

OU



MAGASIN

OU



DÉCHÈTERIE

Adresses sur [quefairedemesdechets.fr](http://quefairedemesdechets.fr)



# BUILDER



Apple and the Apple logo are trademarks of Apple Inc., registered in the U.S. and other countries and regions. App Store is a service mark of Apple Inc. Google Play and the Google Play logo are trademarks of Google LLC. Tencent and the Tencent logo are trademarks of Tencent Inc.

LEGO.com/devicecheck



LEGO® Builder



# NOTRE-DAME DE PARIS

☞ „Man kann sich Paris nur schwer ohne die majestätische Kathedrale Notre-Dame vorstellen. Im Laufe der Jahrhunderte hat dieses spektakuläre Wahrzeichen der Metropole den Elementen, der Revolution und verheerenden Zerstörungen getrotzt. Und noch immer zählt sie zu den beliebtesten Touristenattraktionen von Paris. Wenn man sie in all ihrer Pracht erblickt, die der Schwerkraft zu trotzen scheint, fragt man sich unwillkürlich, wie die Architekten, Maurer und Zimmerleute ein derart monumentales Bauwerk errichten konnten. Die Arbeiten begannen bereits vor fast 900 Jahren und zogen sich über mehrere Jahrhunderte hin. Wir haben uns von den genialen Bautechniken dieser begnadeten Handwerker inspirieren lassen, um dieses prachtvolle Bauwerk mit all seinen feinen Details als LEGO® Modell nachzubilden.“

„Diese Bauanleitung wird dich durch den Bauprozess führen. Jeder Stein, den du aufsteckst, entspricht dabei einem bestimmten architektonischen Element der echten Kathedrale. Jedes Mal, wenn du die Steine aus einem Beutel zusammengesteckt hast, siehst du ein Modell, das die Kathedrale zu einem bestimmten Zeitpunkt während des Baus von 1163 bis heute darstellt.“

*Rok Žgalin Kobe, Senior LEGO® Designer*

1163-1182

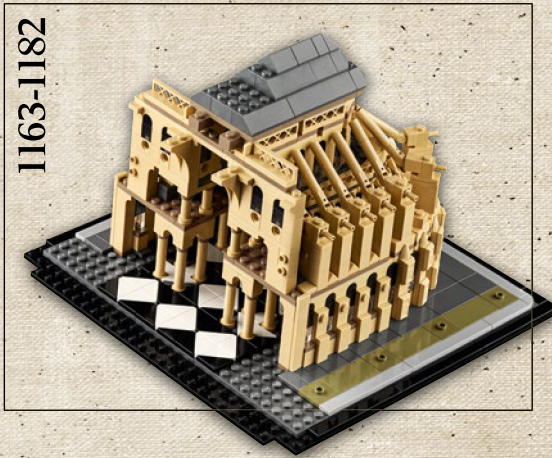

*1163-1182: Die Ostseite der Kathedrale wurde zuerst fertiggestellt und diente bereits als Kirche, während die Bauarbeiten am Rest der Kathedrale fortgesetzt wurden.*

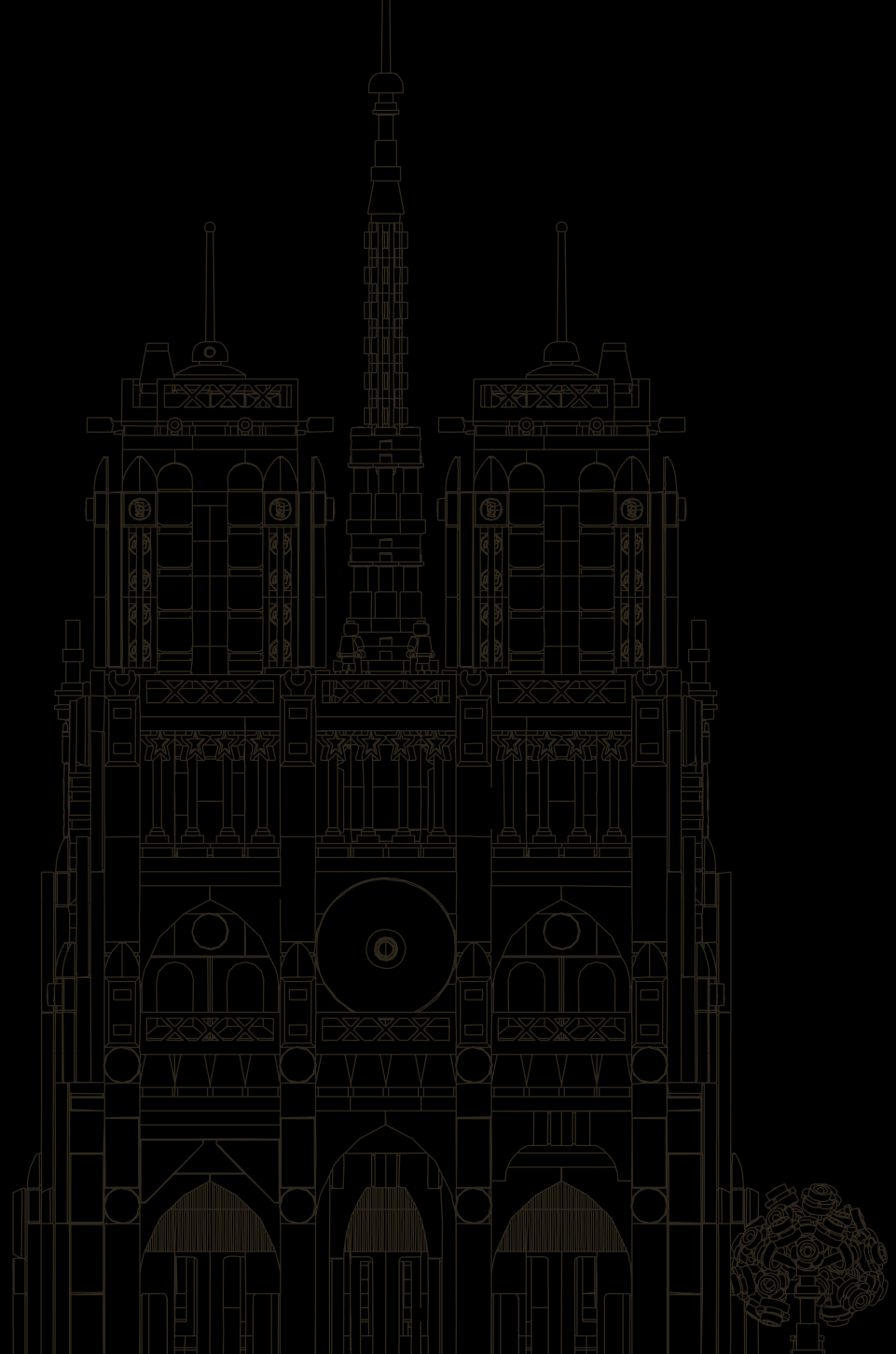

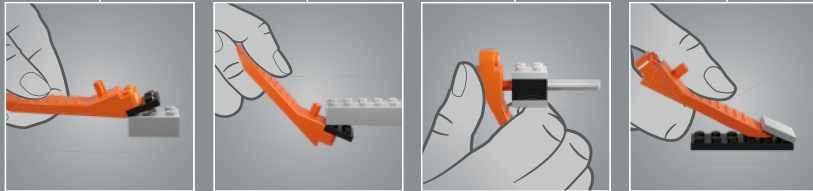
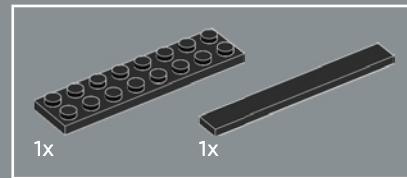
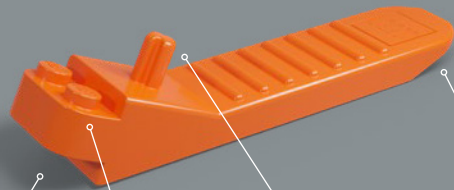

1

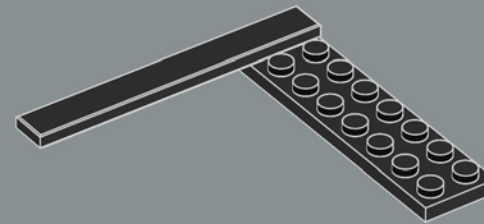

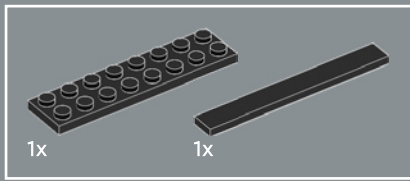

2

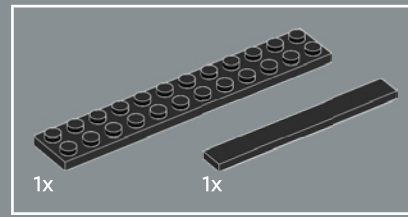
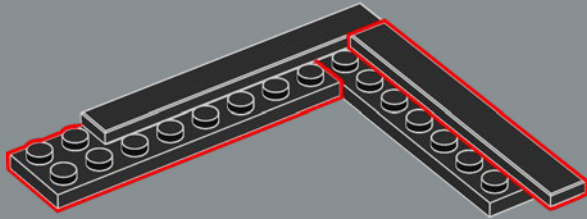

3

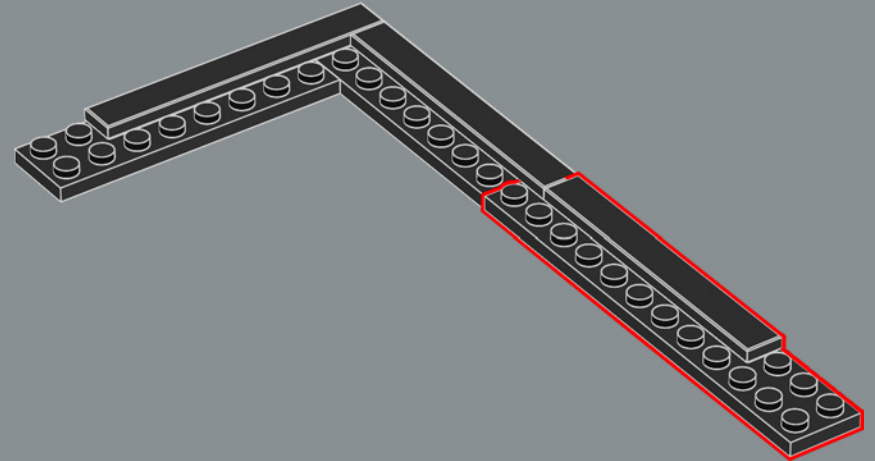

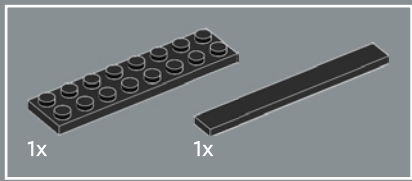

4

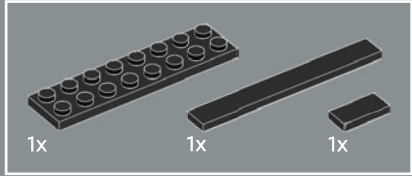
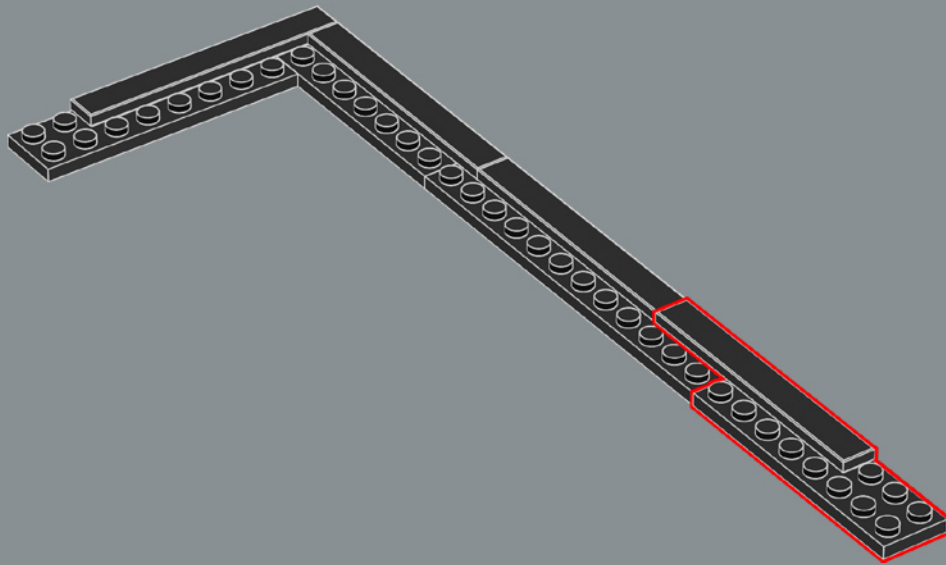

5

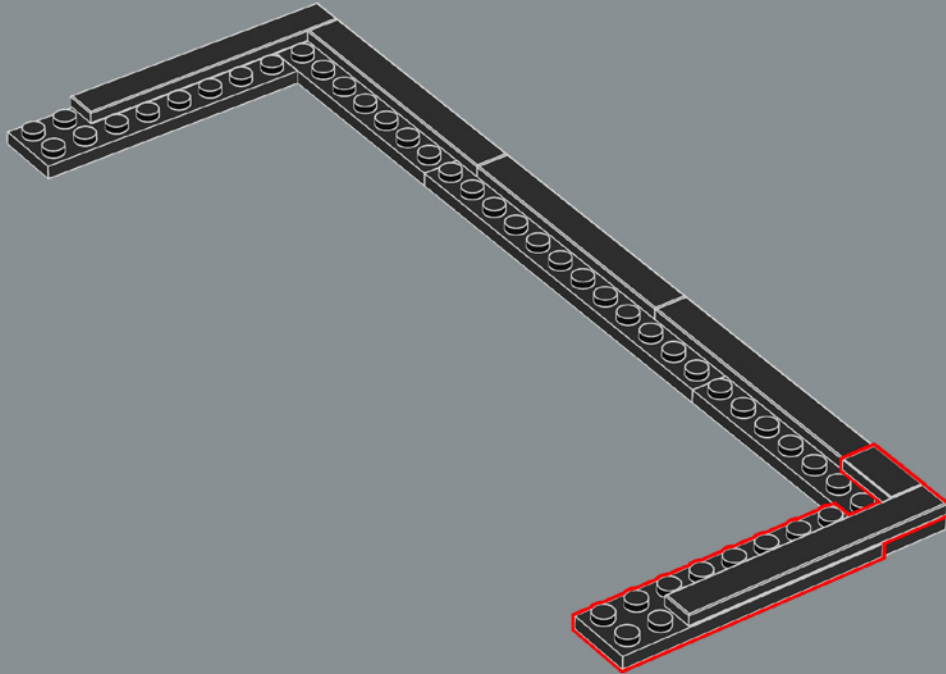

8



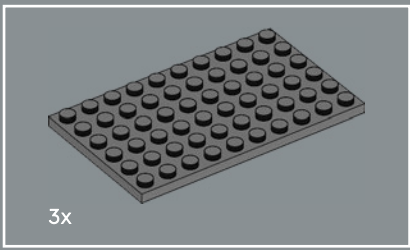

6

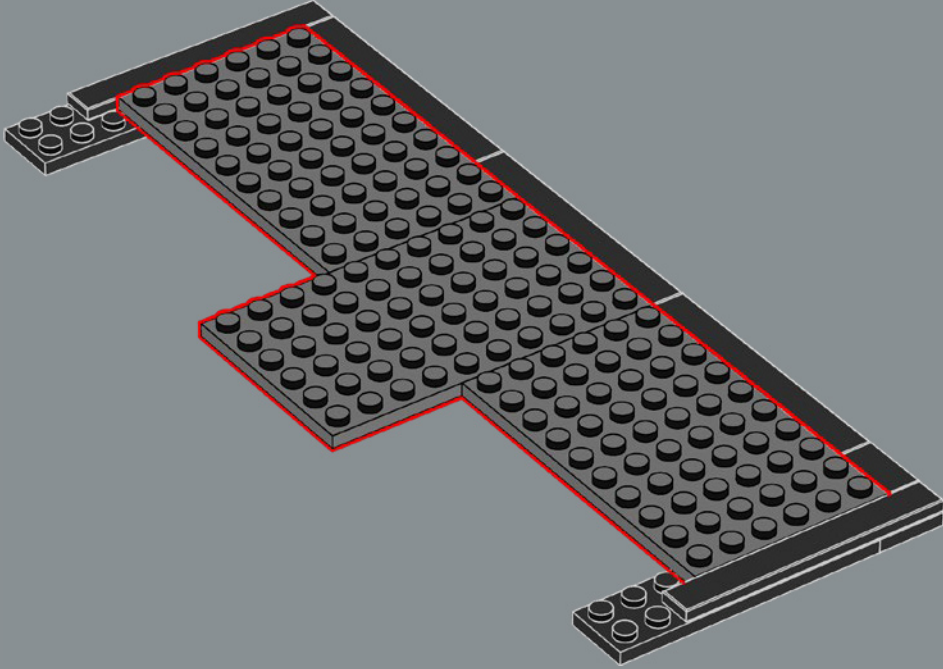

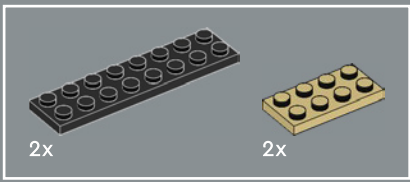

7

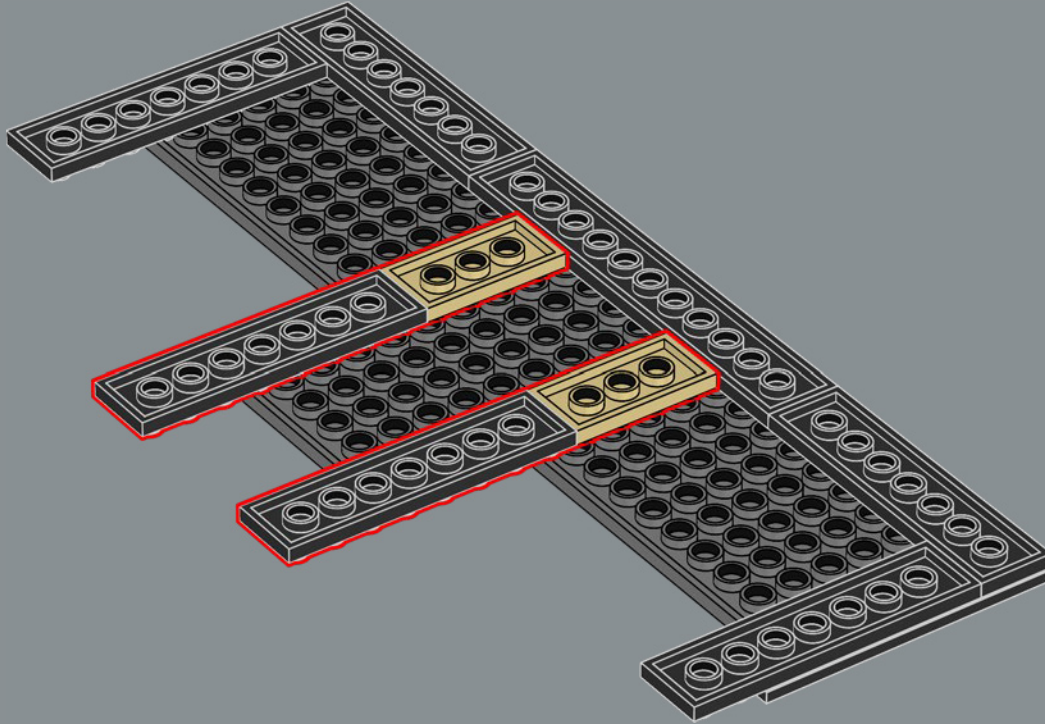

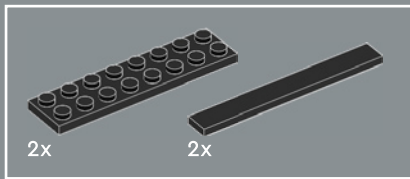

8

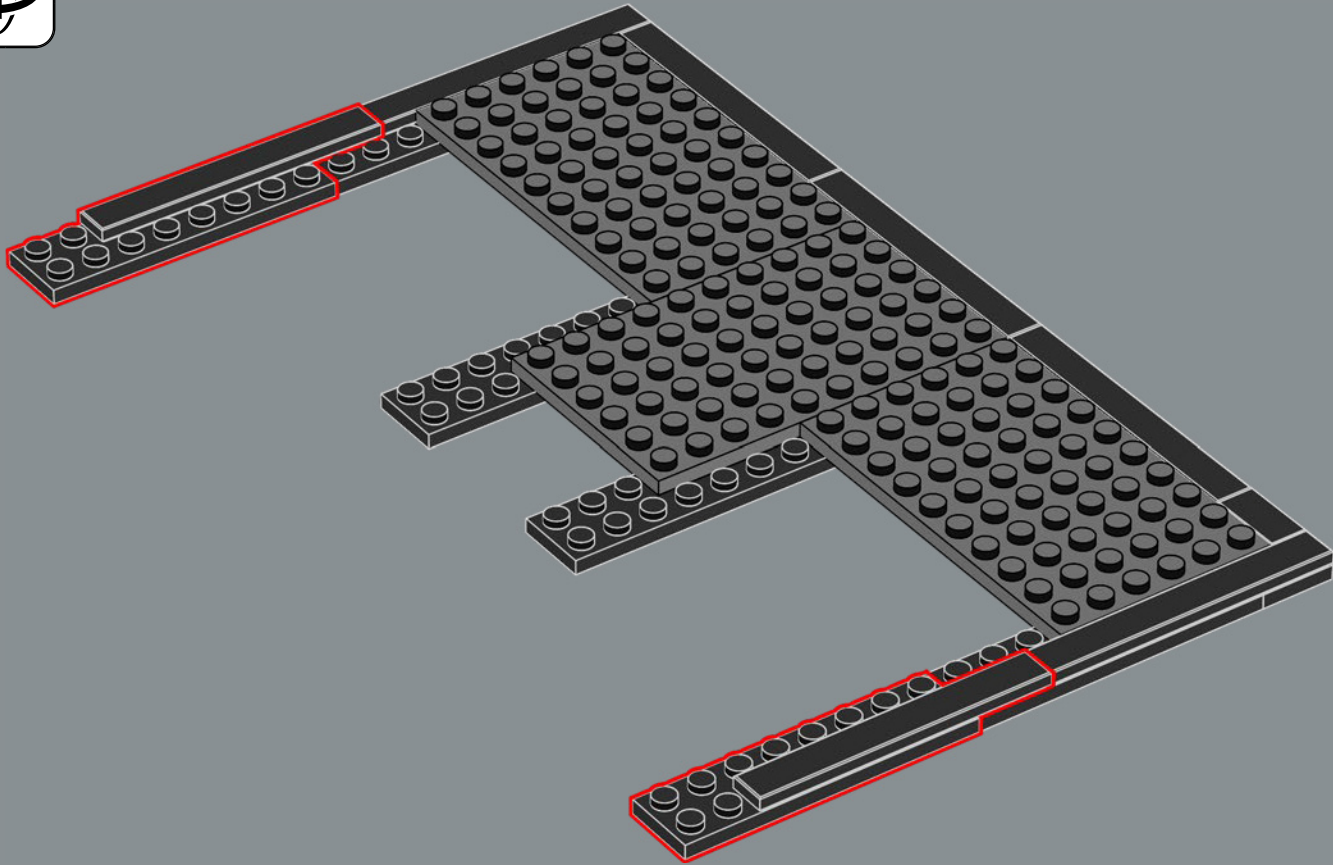

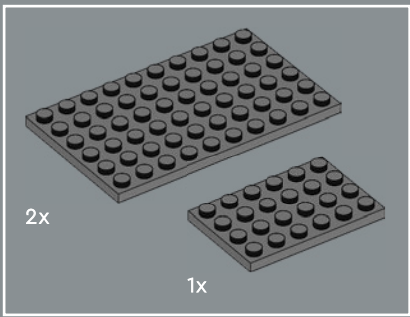

9

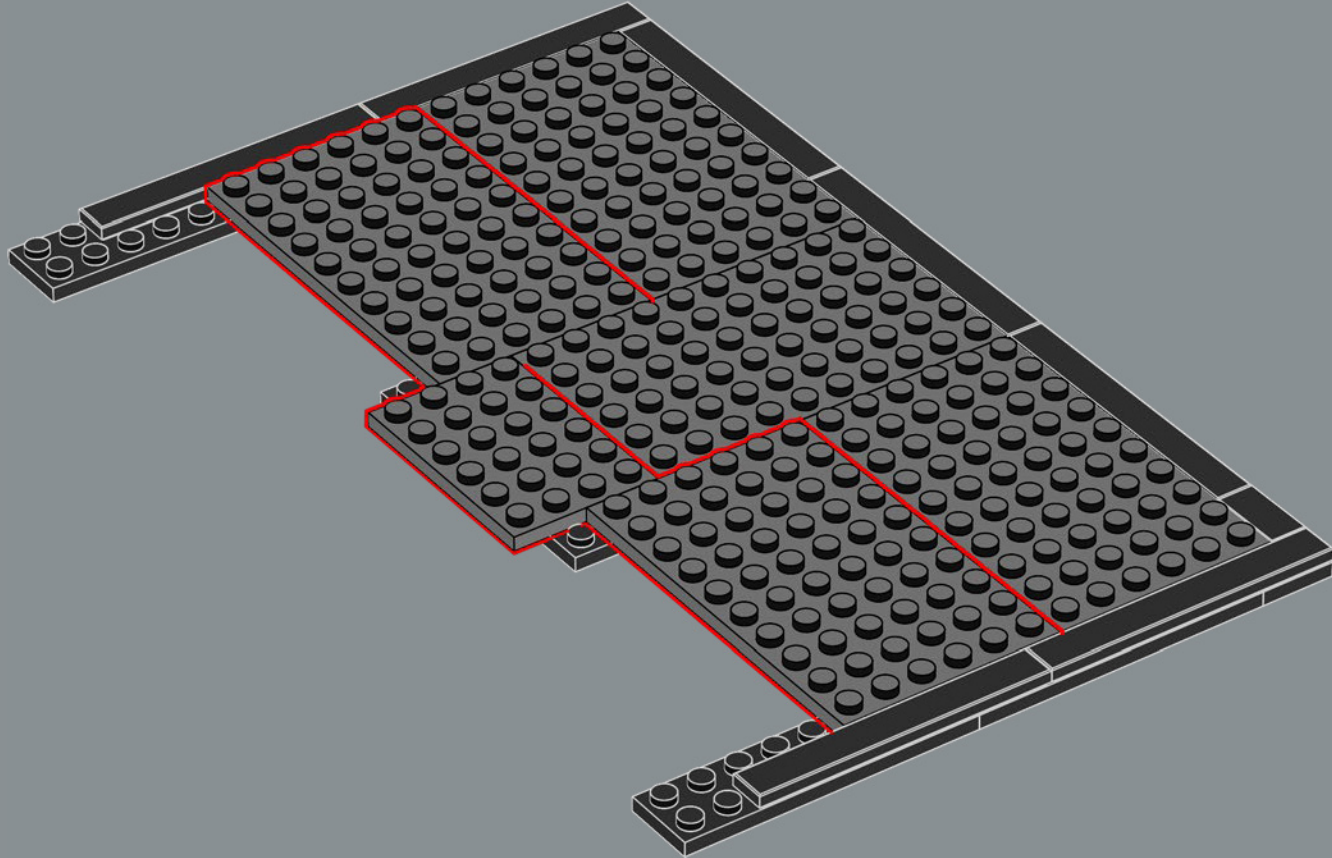

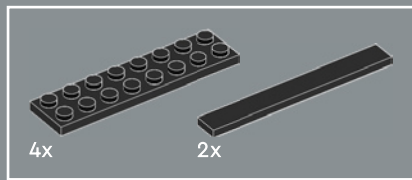

10

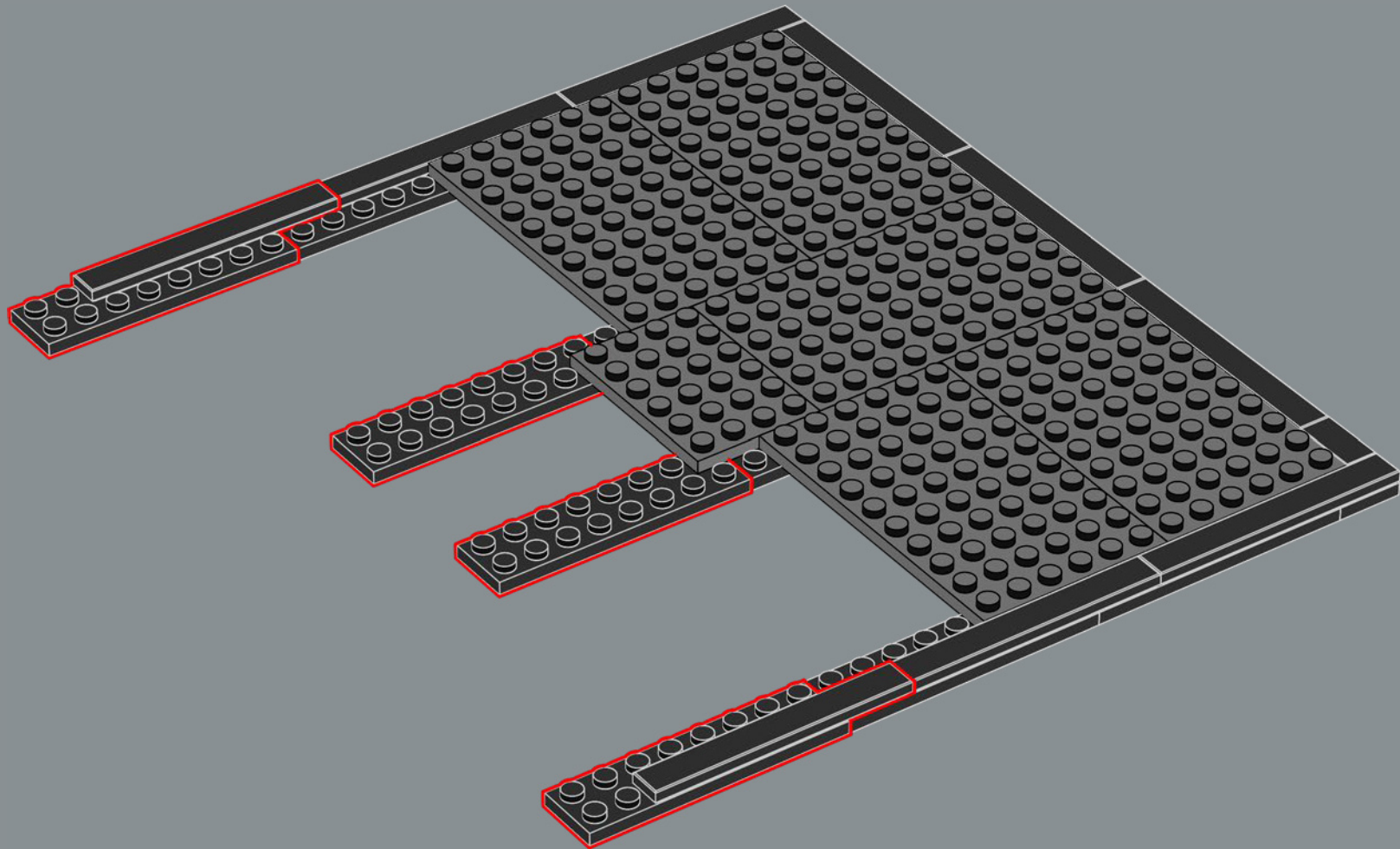

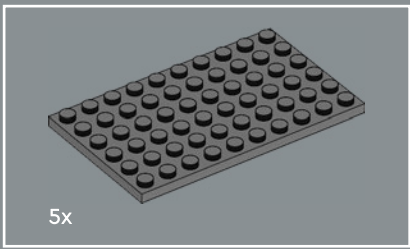

11

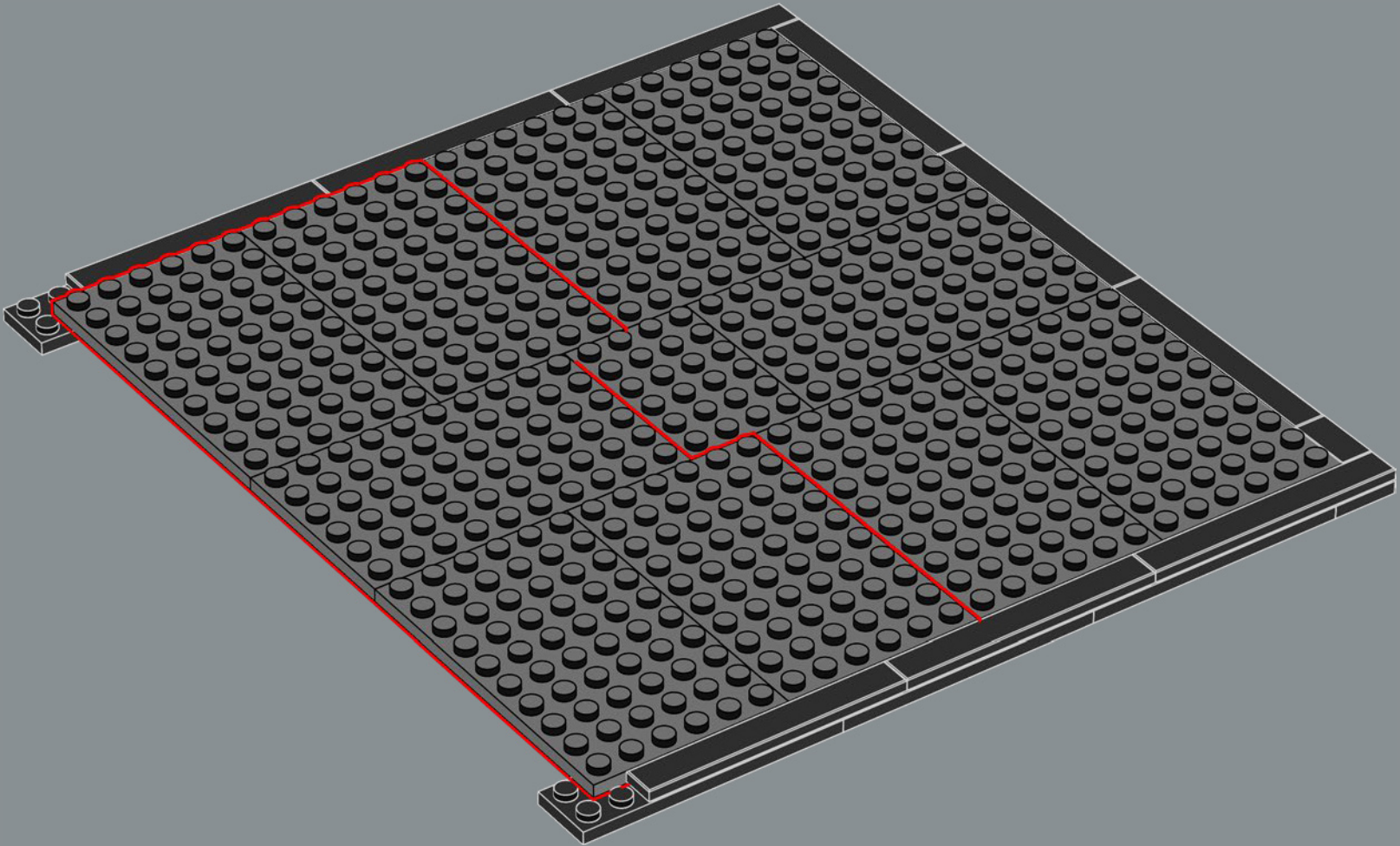

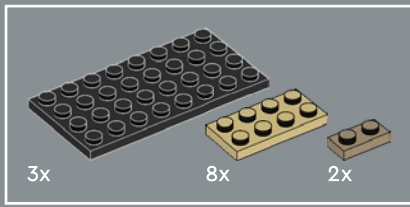

12

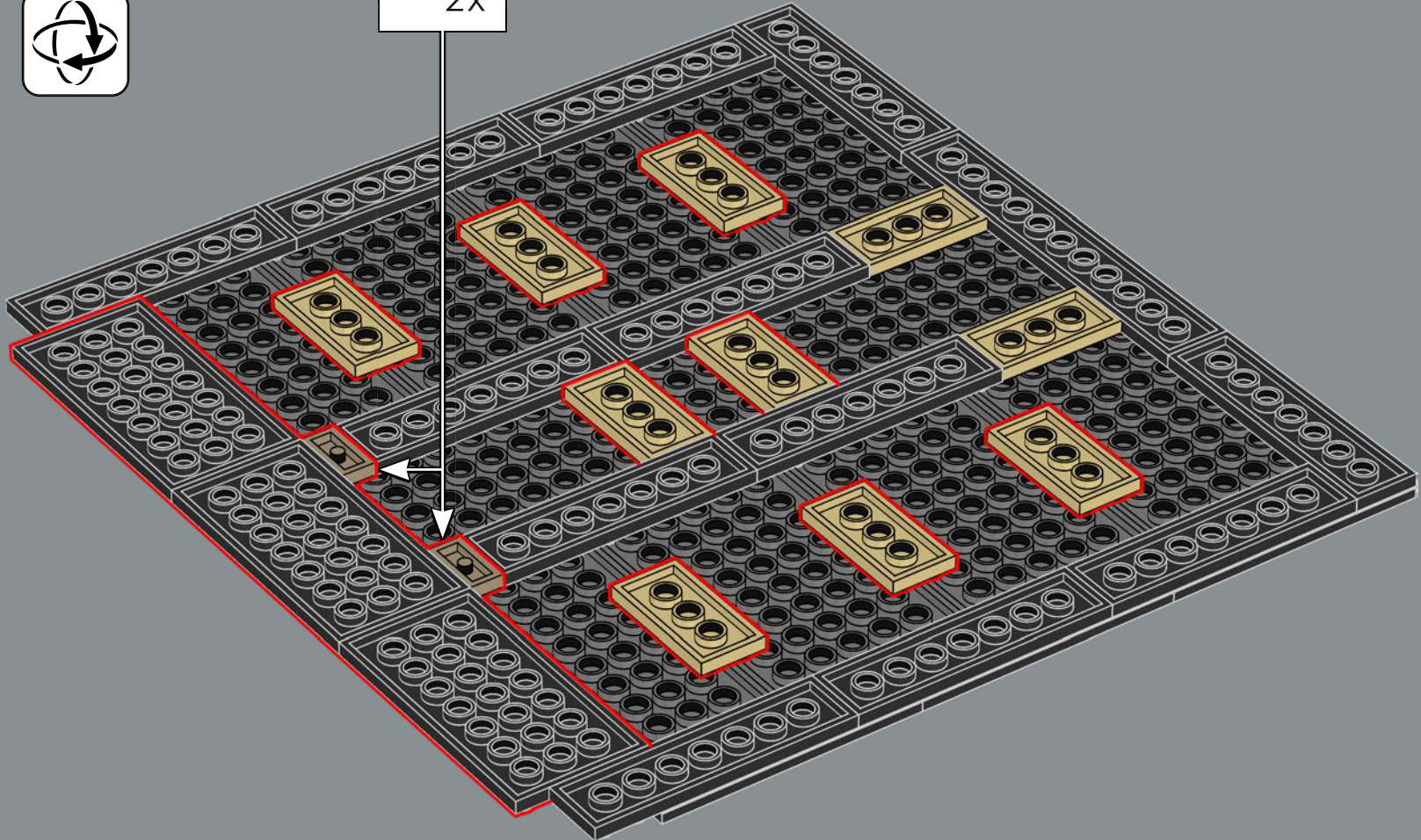
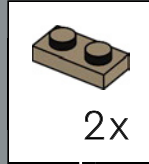

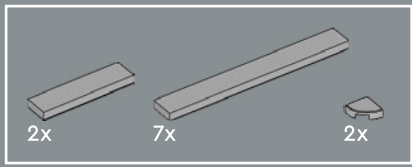

13

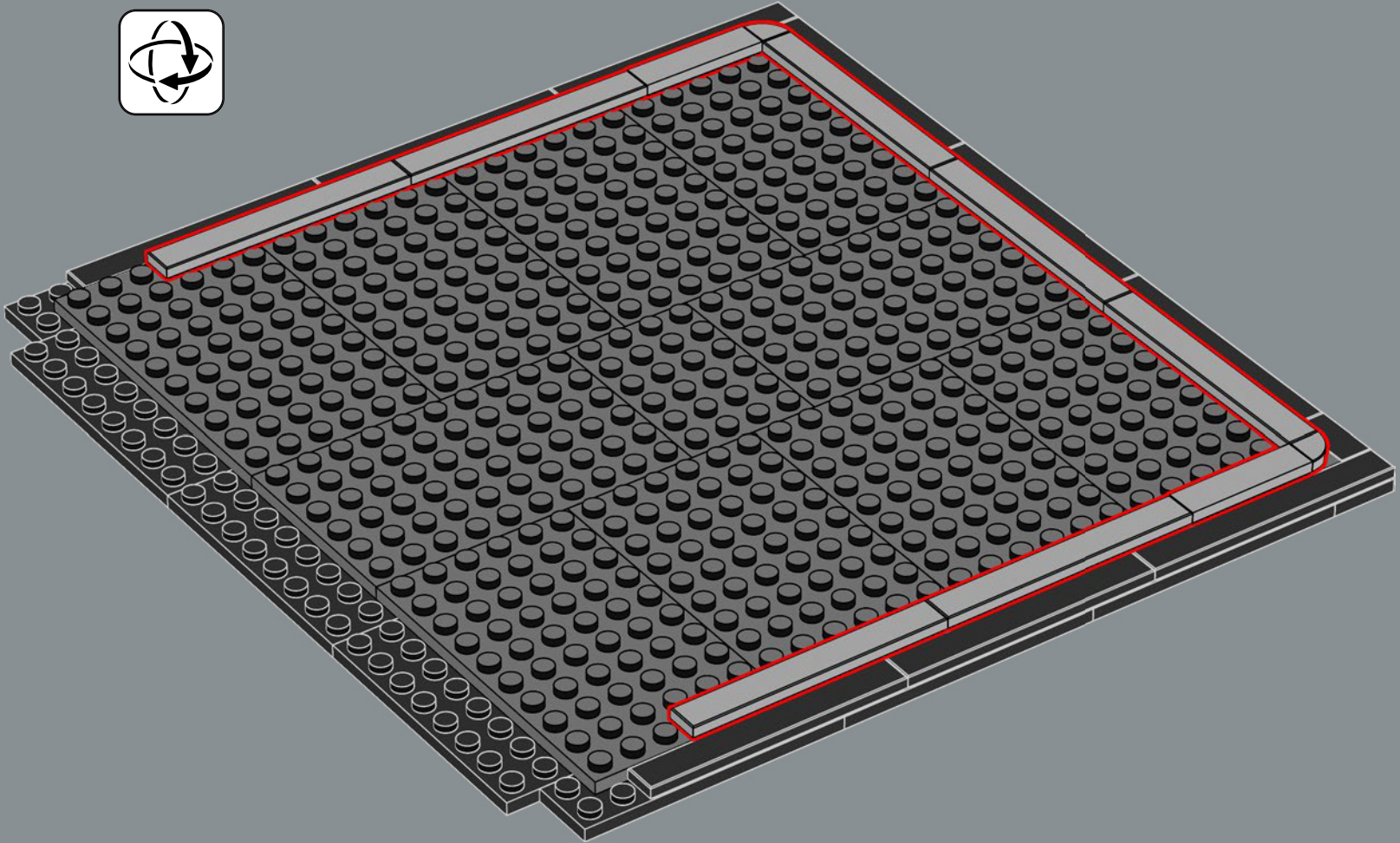



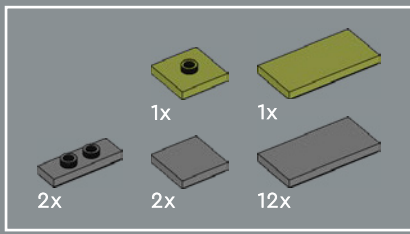

14

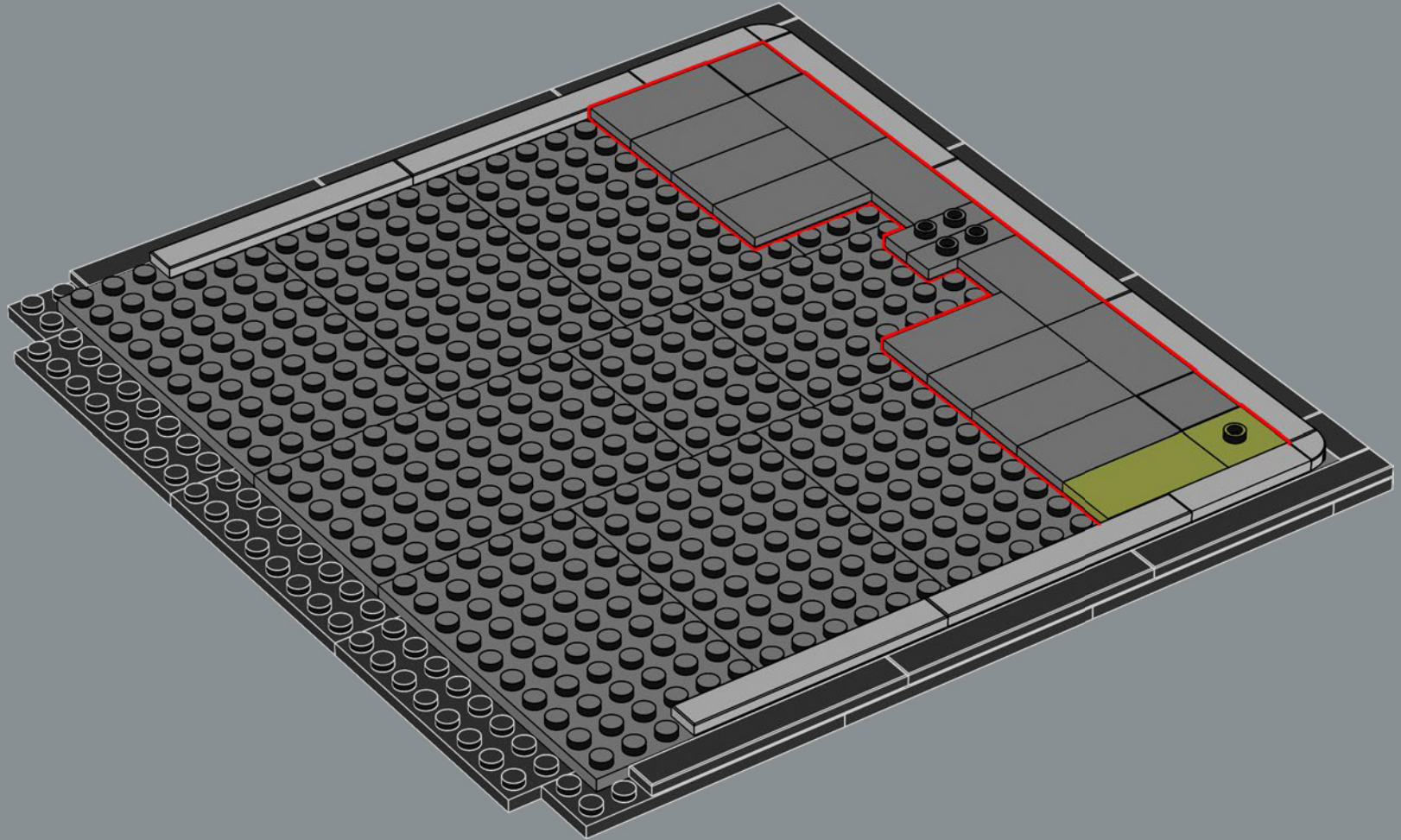

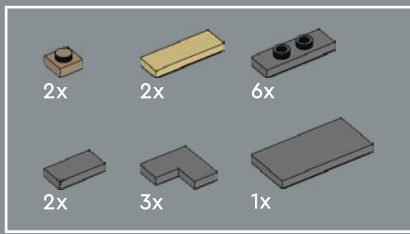

1163: Die Baupläne für die Kathedrale Notre-Dame sind fertig.  
Die Bauarbeiten beginnen, und Papst Alexander III. beaufsichtigt  
das Setzen des ersten Steins.

15

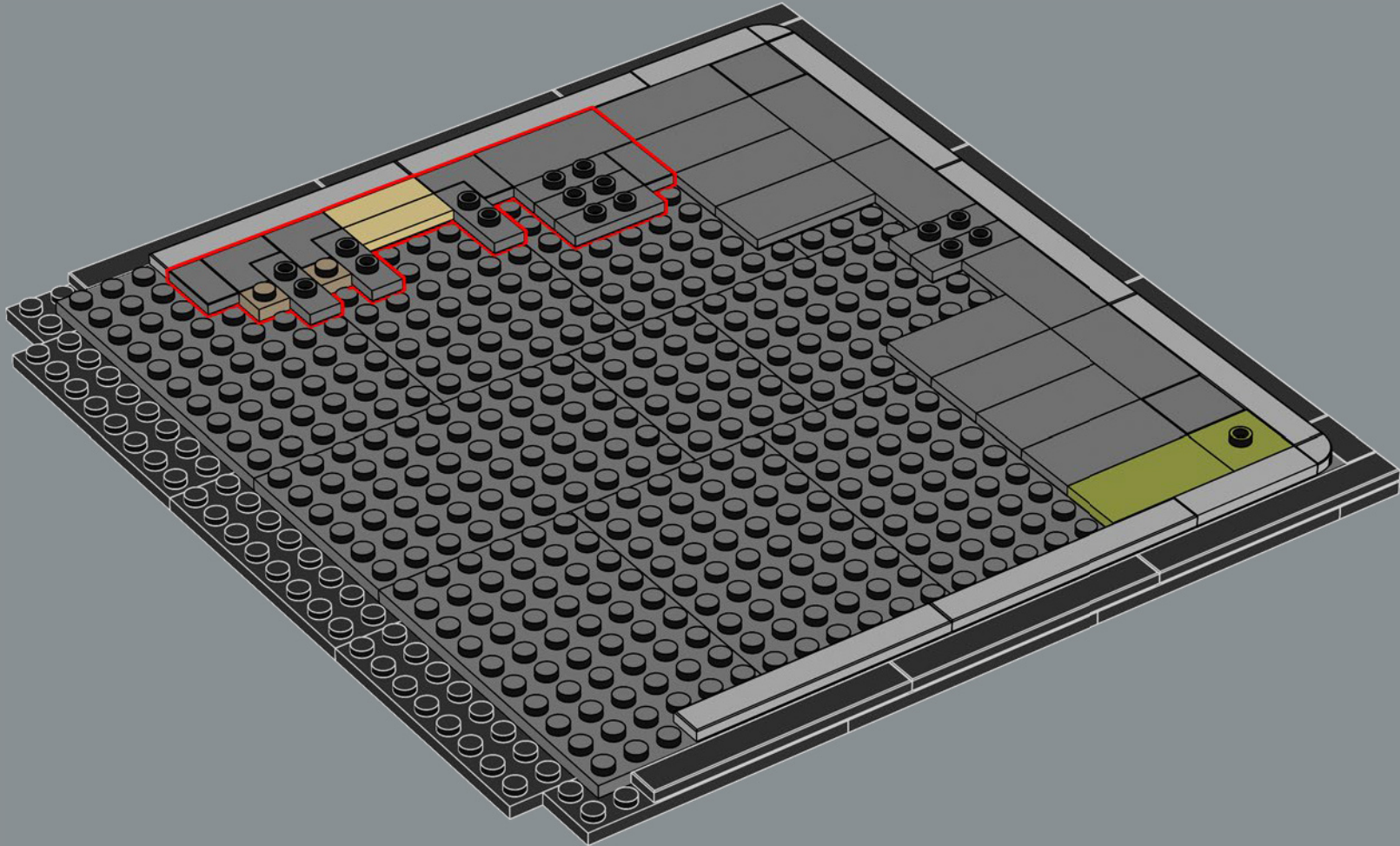

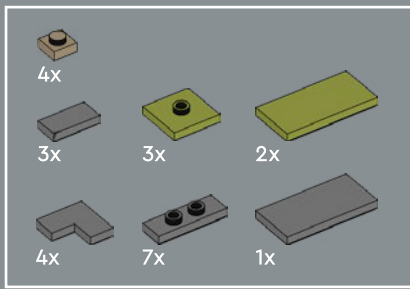

16

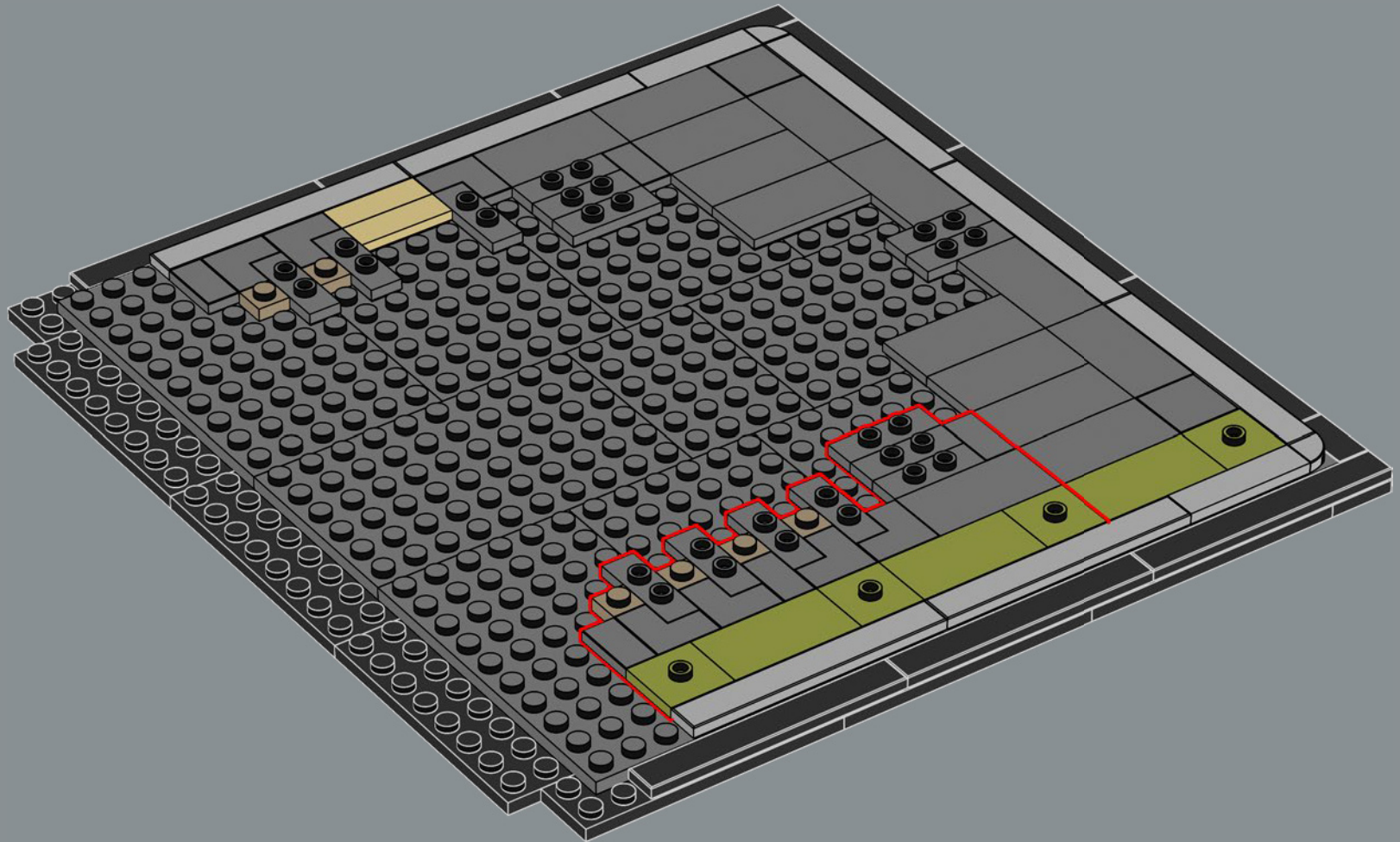

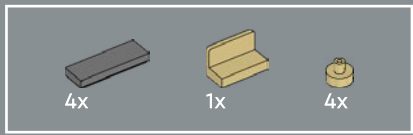

17

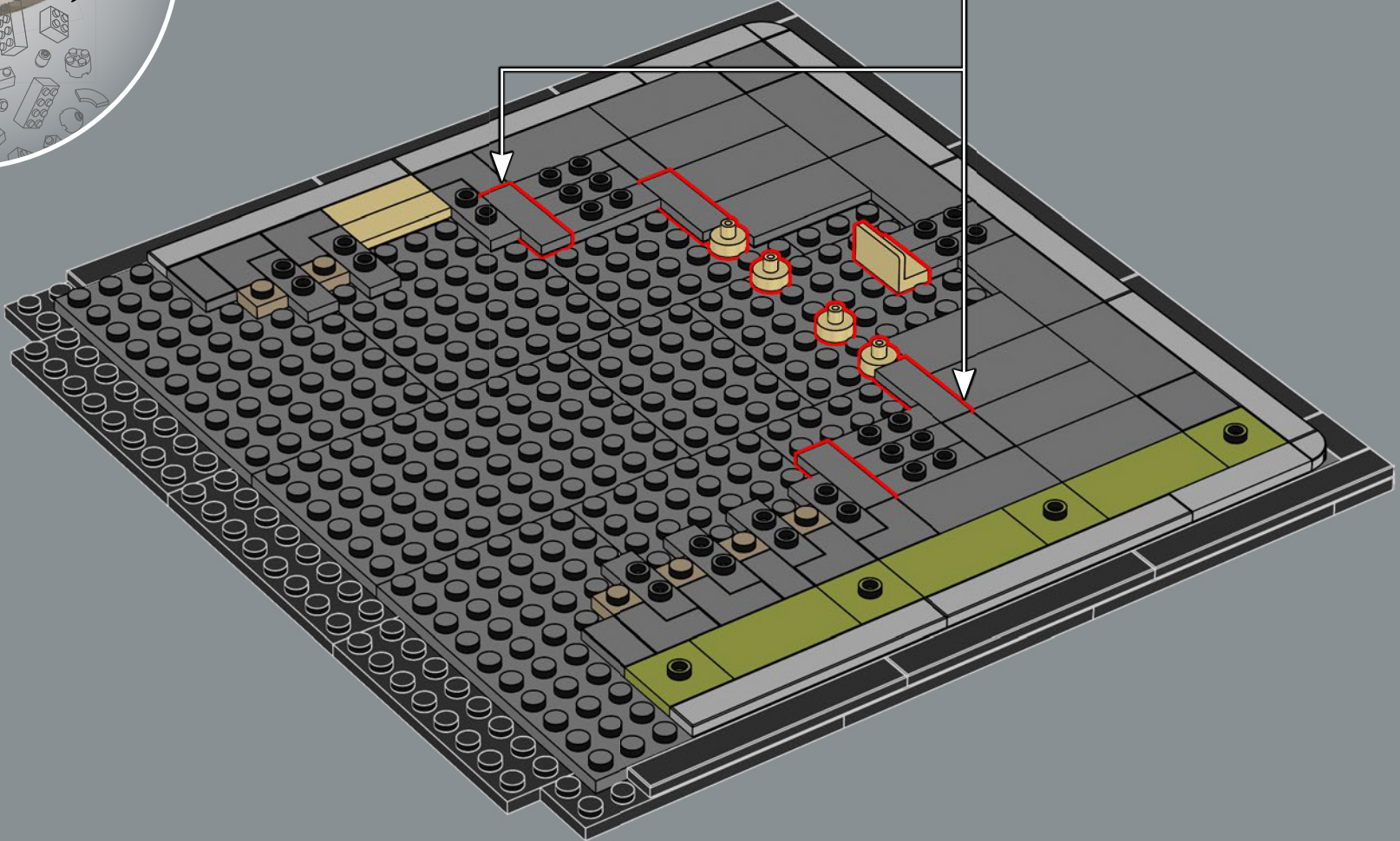
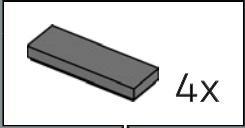



18

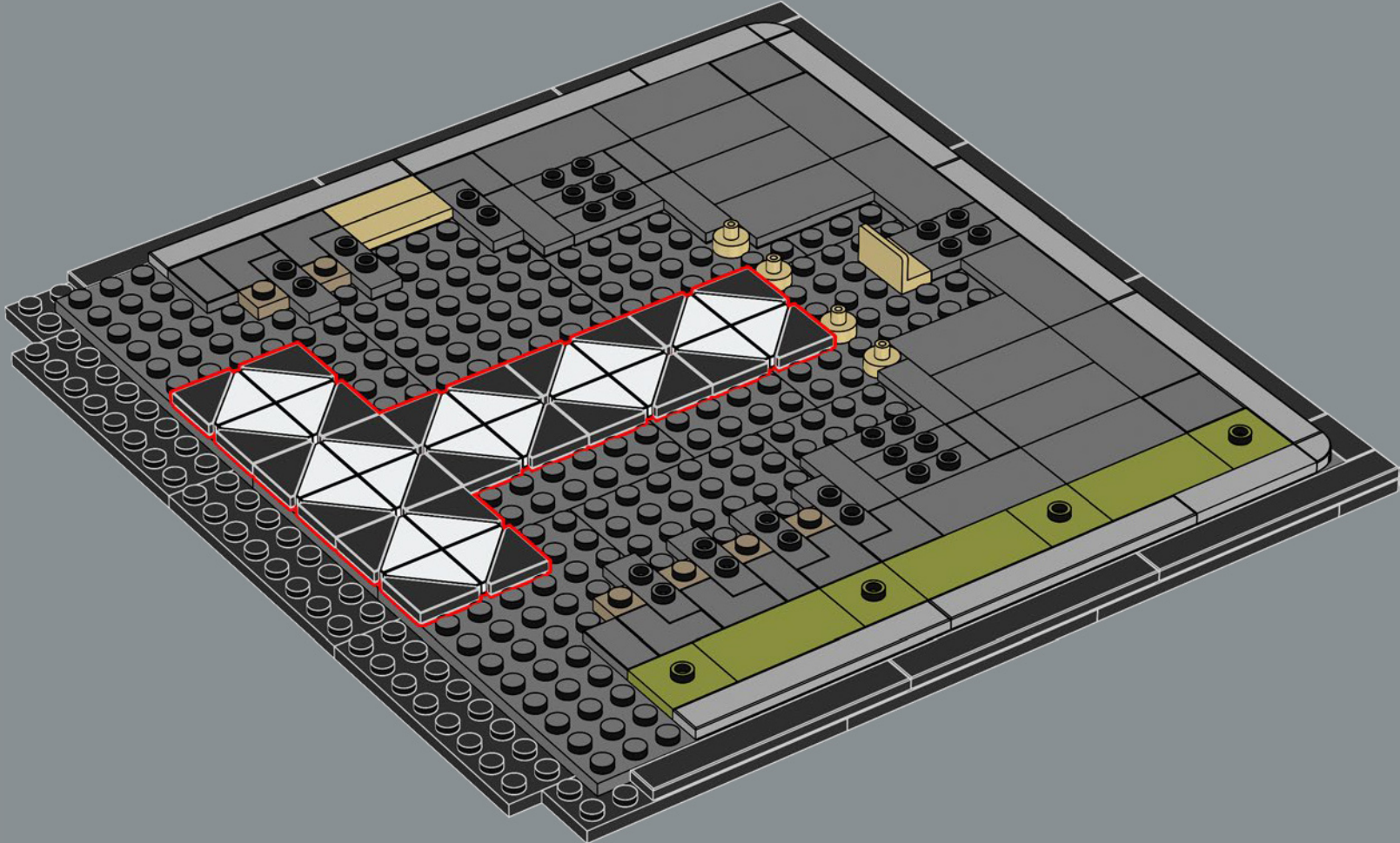



20x

19

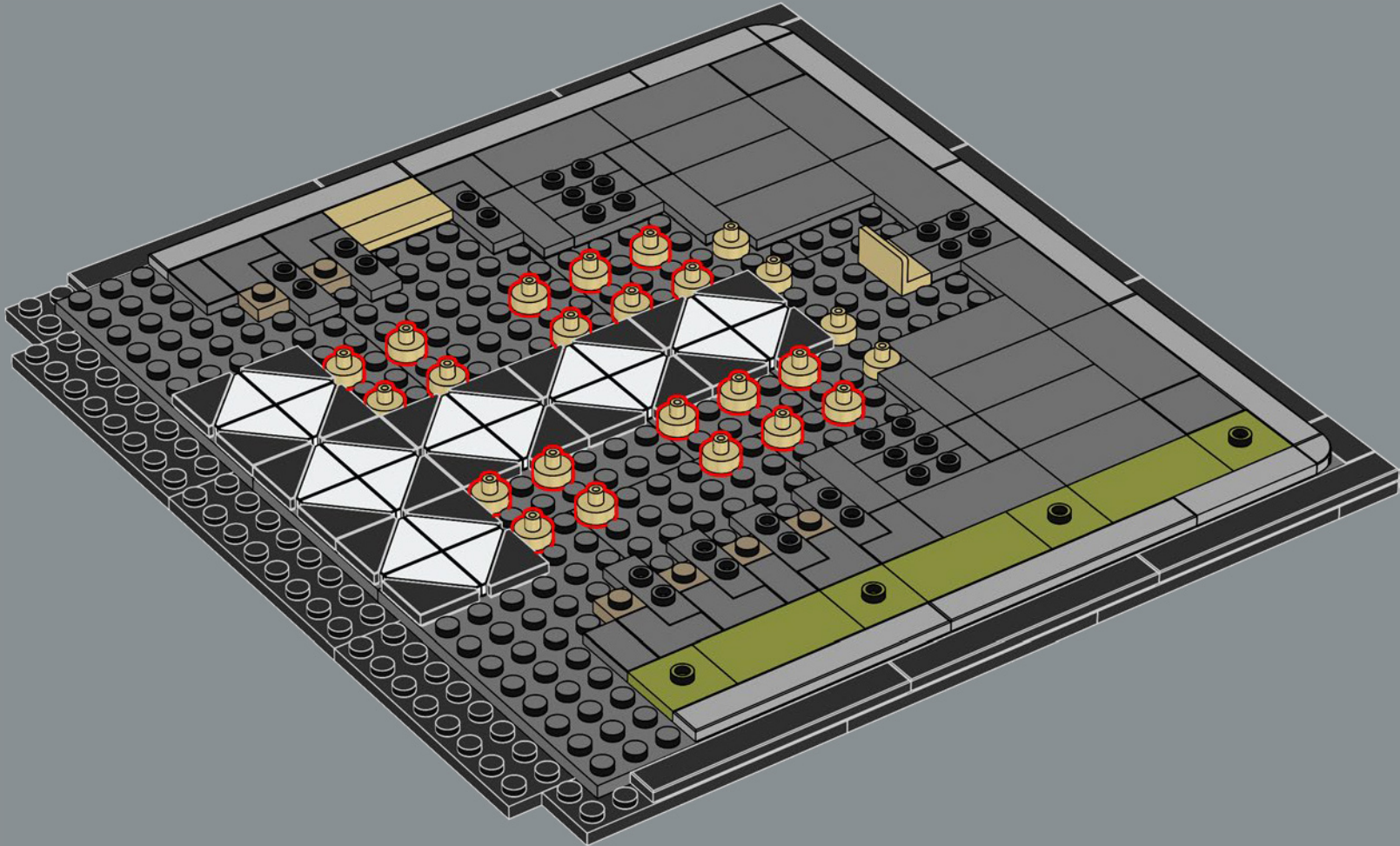

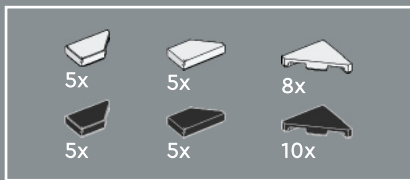

20

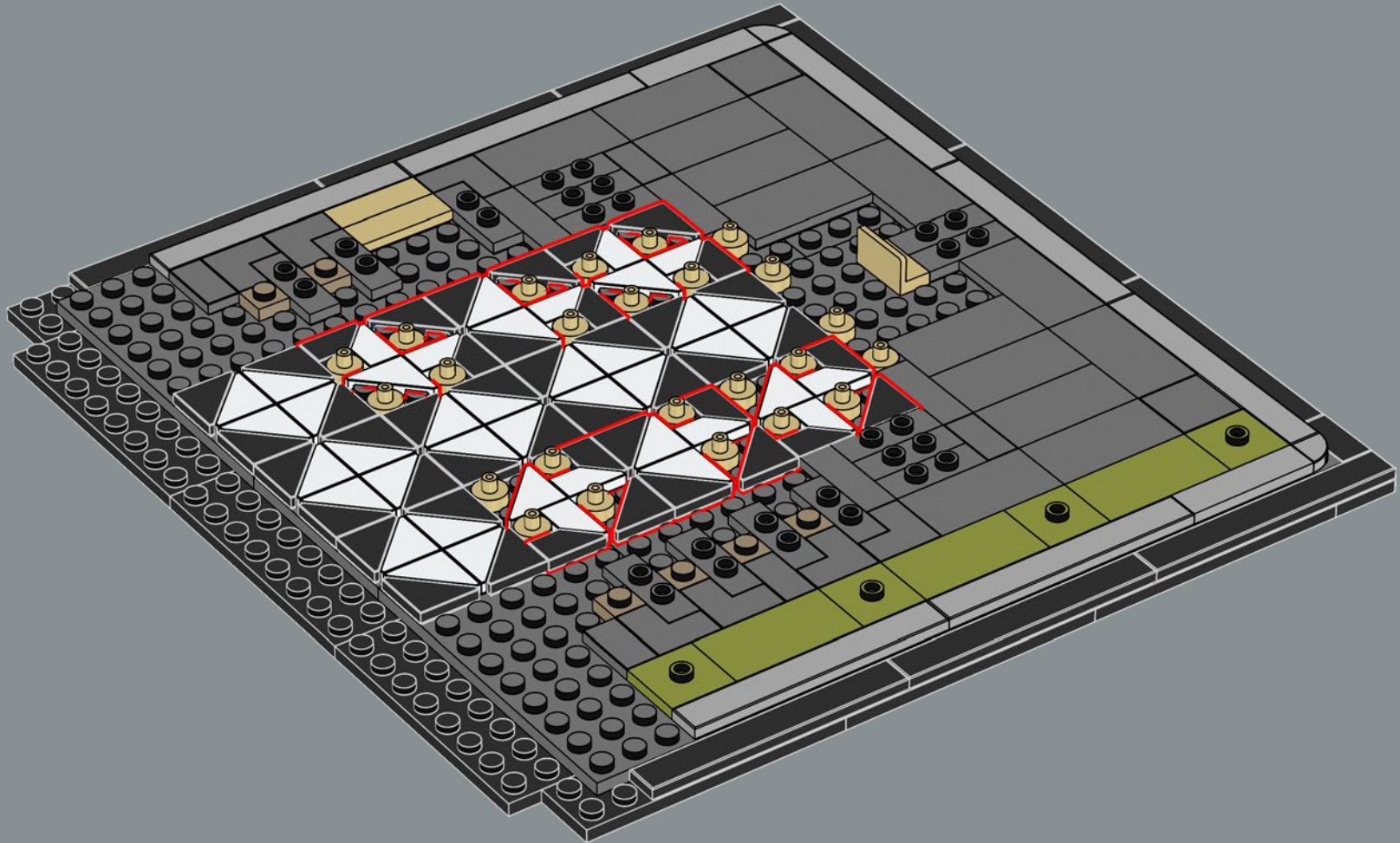

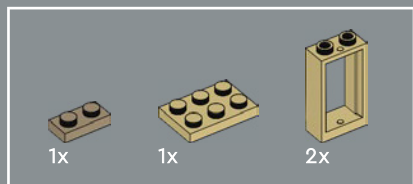

21

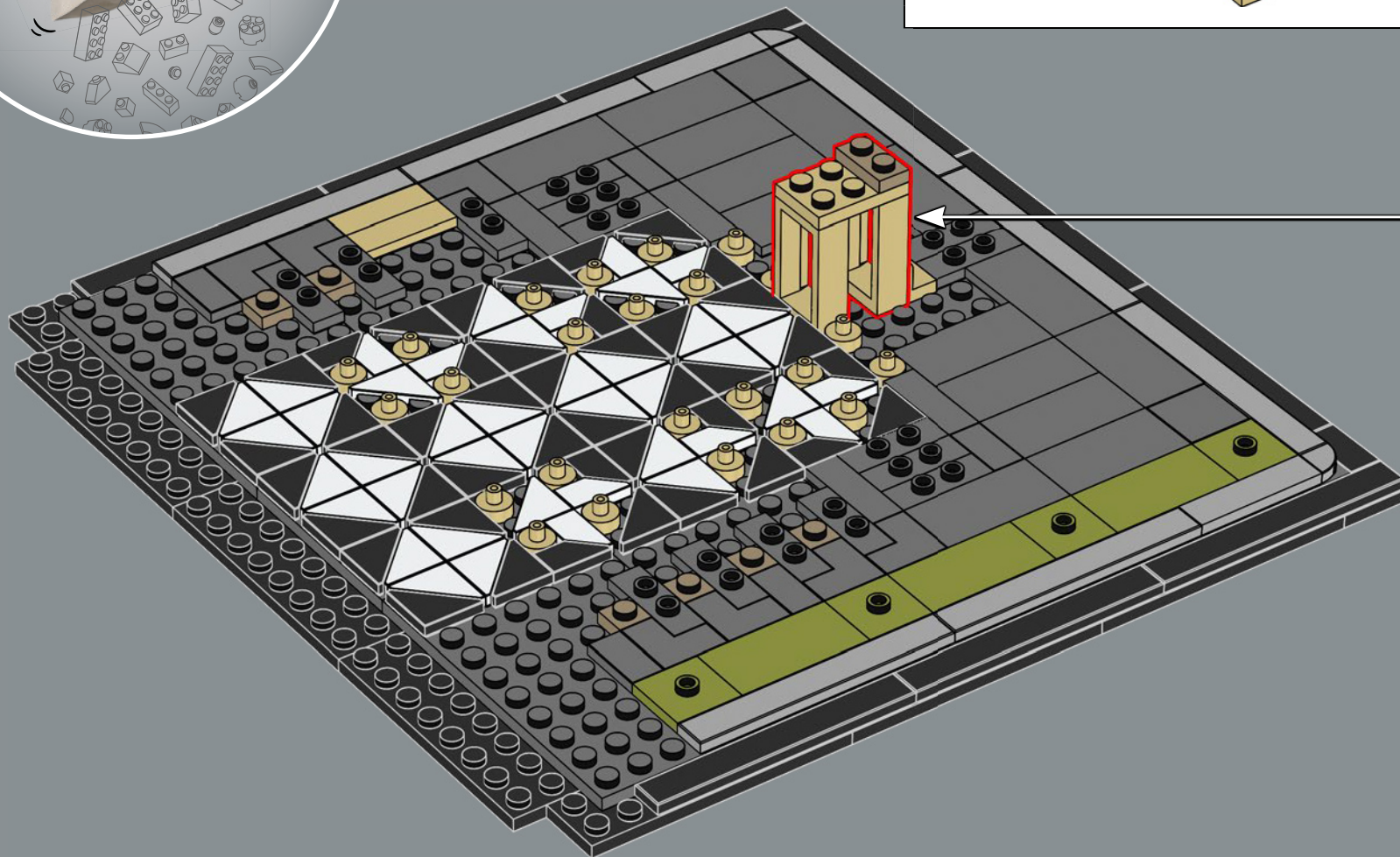
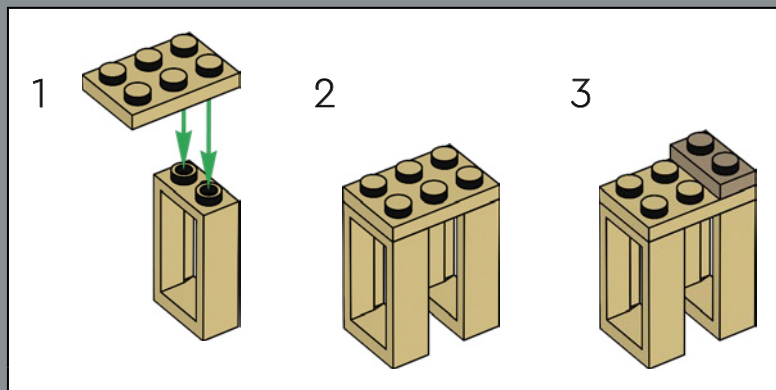



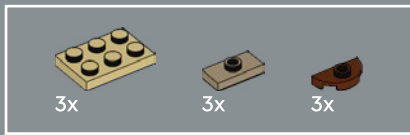

22

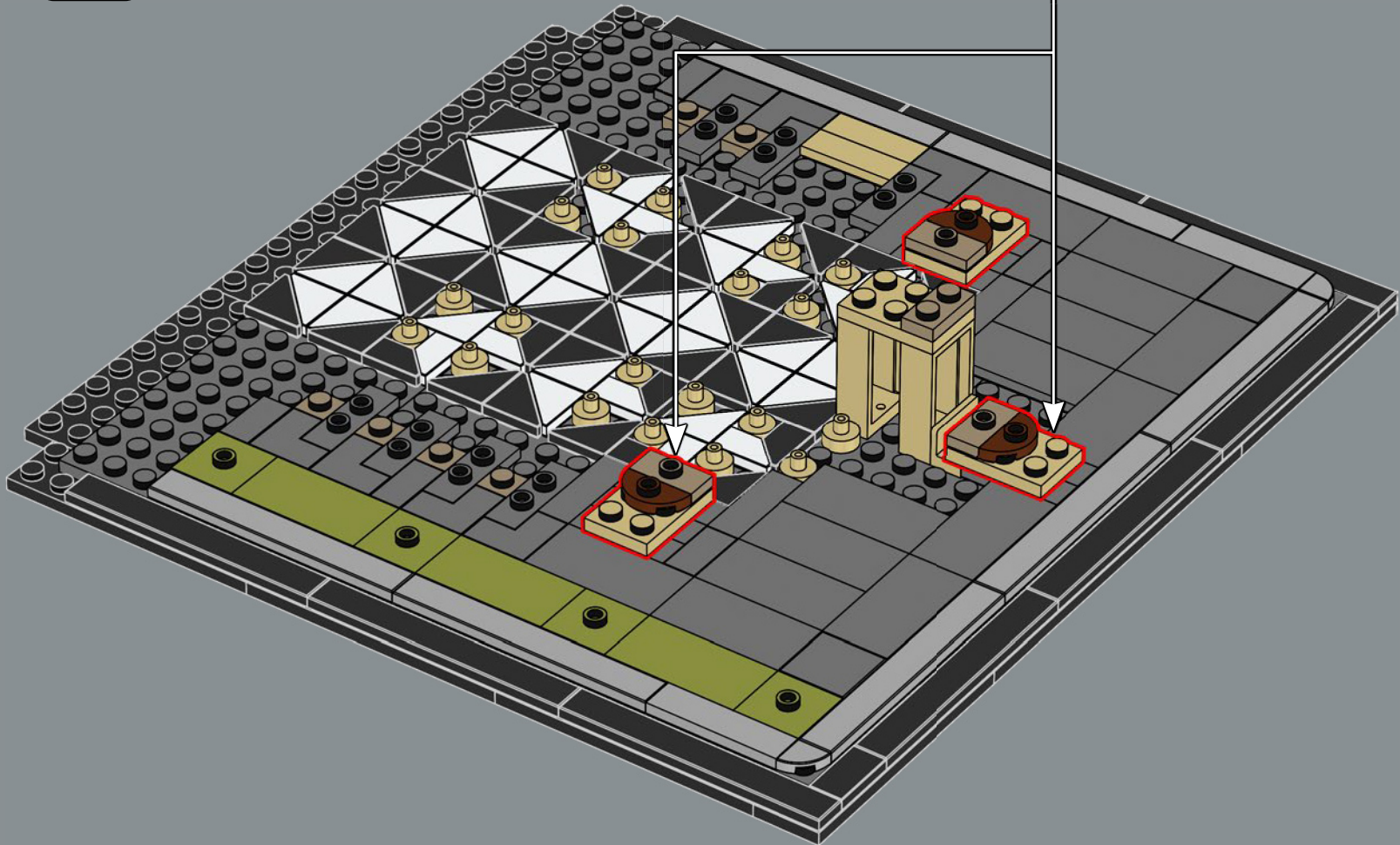
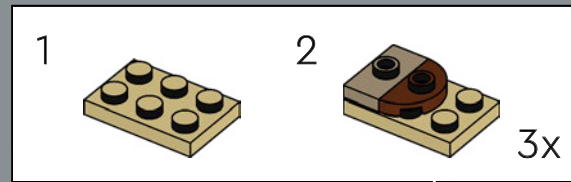

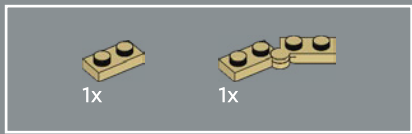

23

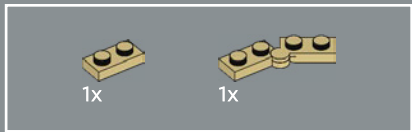
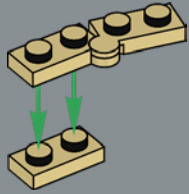

24

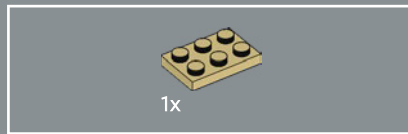
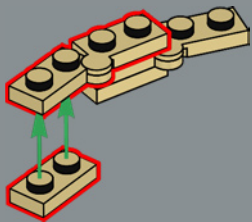

25

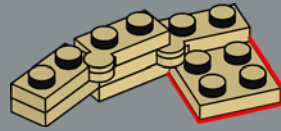

26

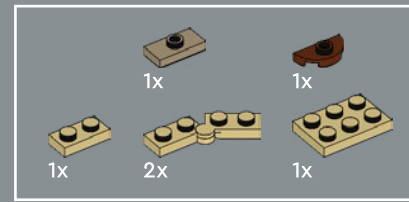
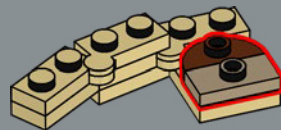

27

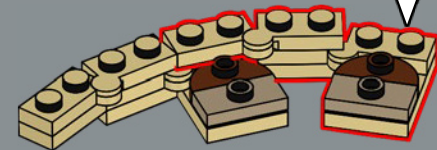
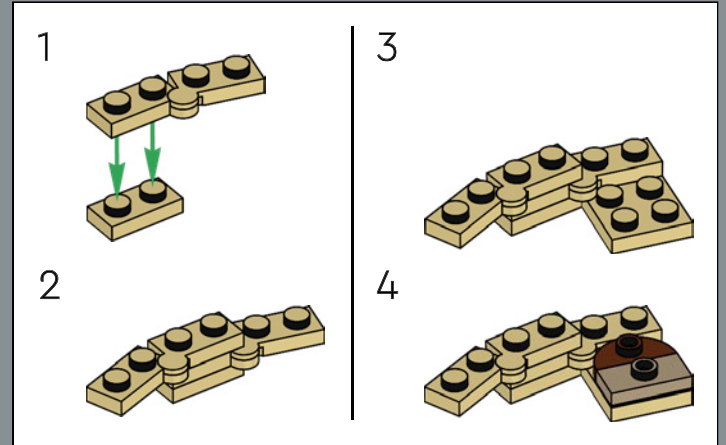

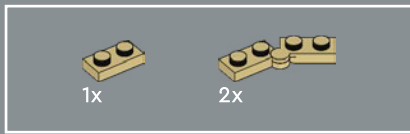

28

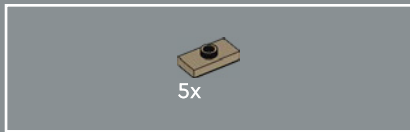
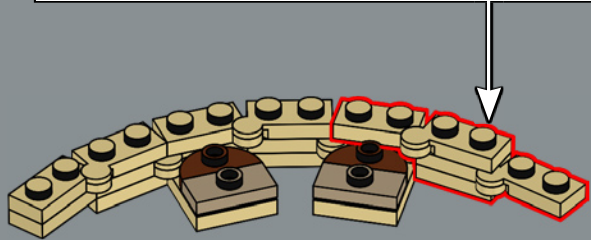
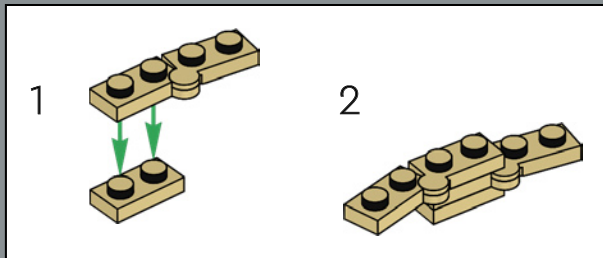

29

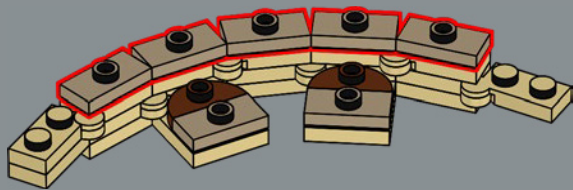

30

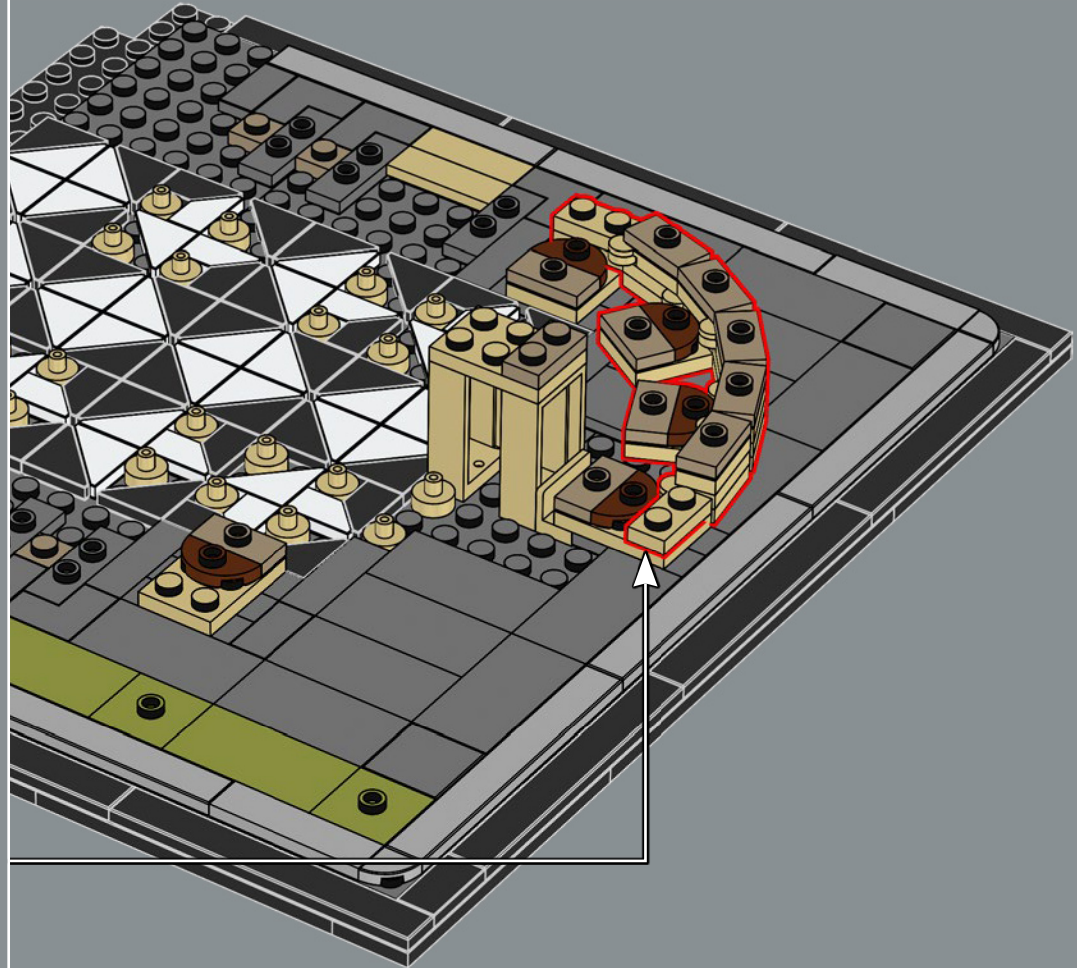

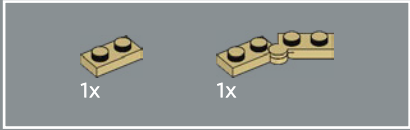
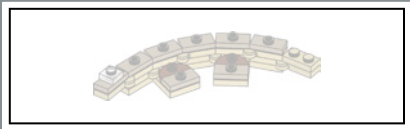

31

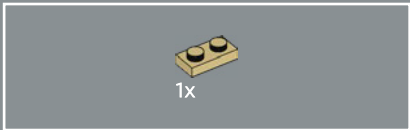
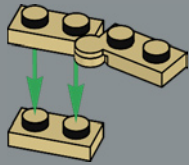

32

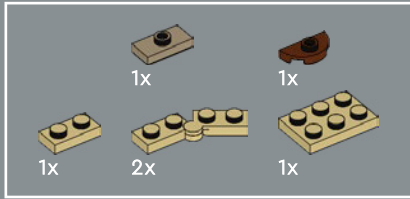

33

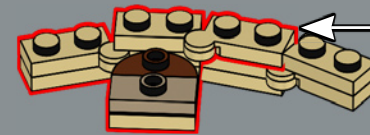
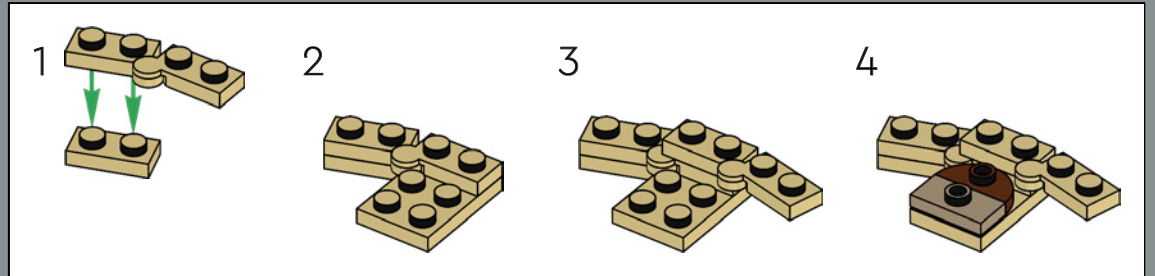



1163: Wo die Elemente aus dem Bauplan platziert werden, wird mithilfe mehrerer Kreise festgelegt. Diese Kreise werden mit Schnüren unterschiedlicher Länge aufgezeichnet, die an einer Stange in der Mitte der Kathedrale befestigt sind.

37

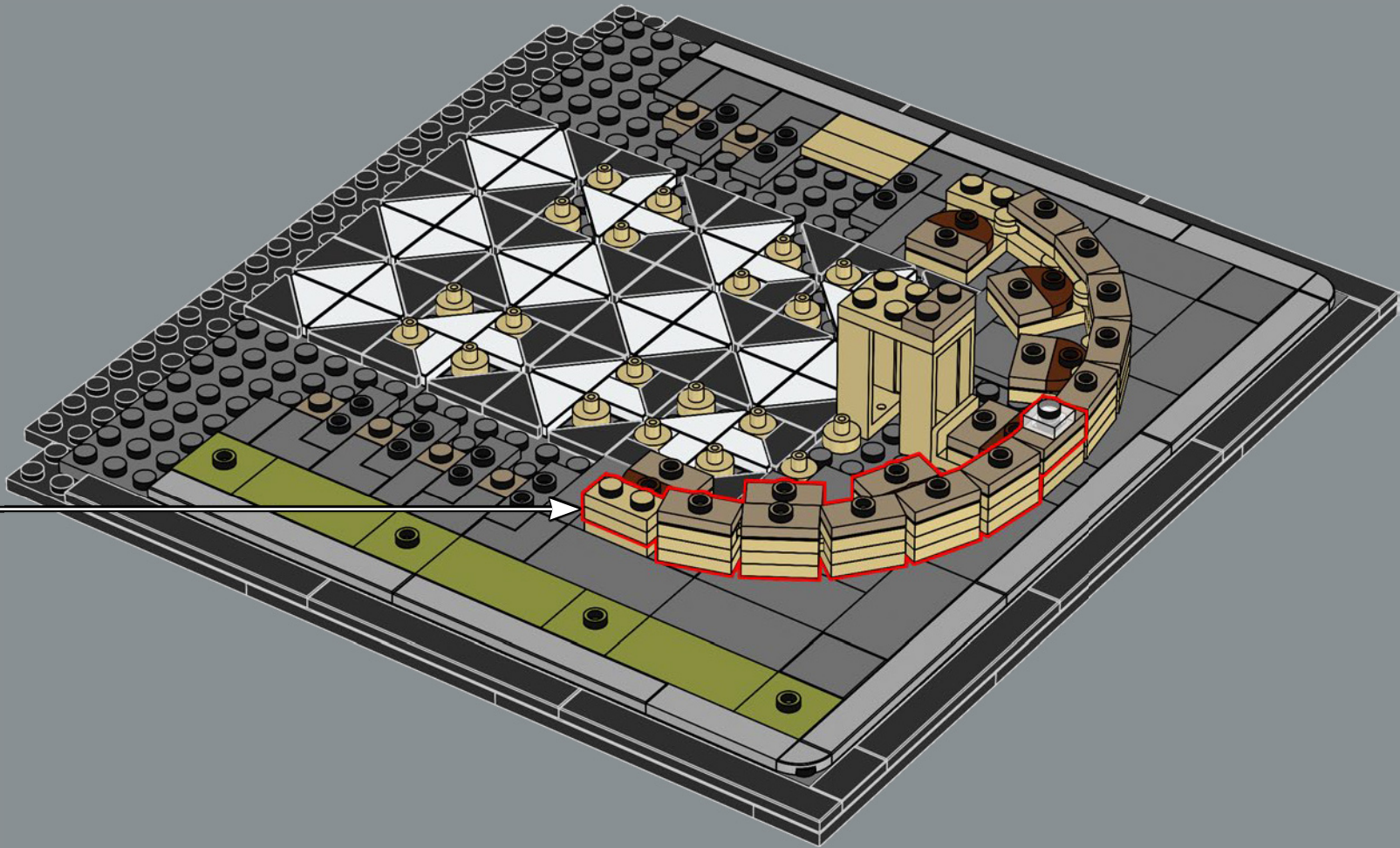

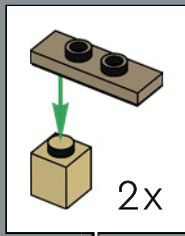
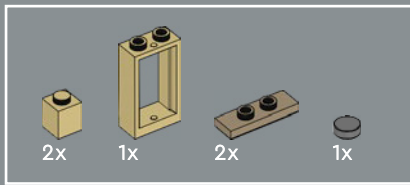

38

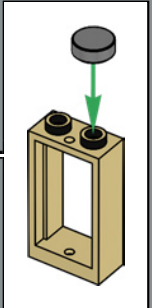
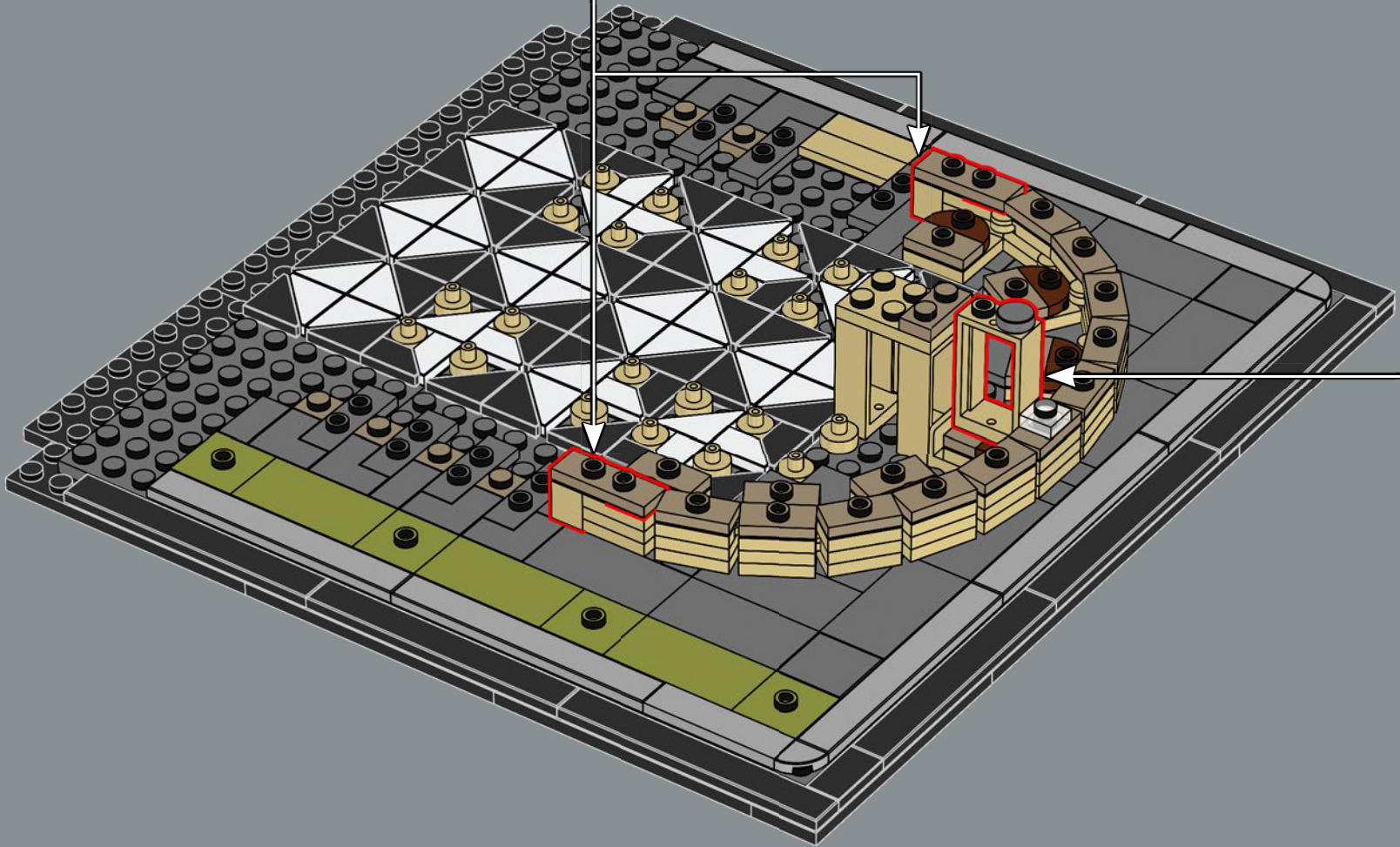

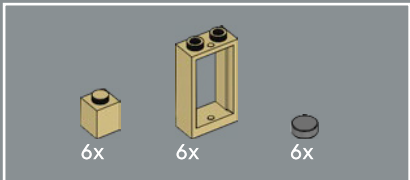

39

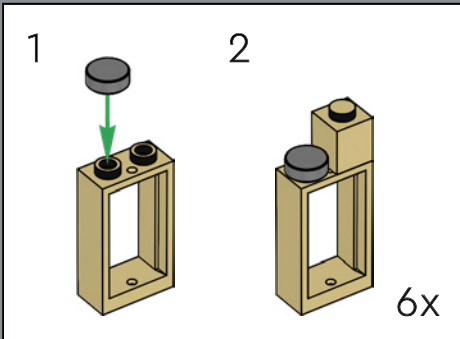

1163-1170: Das Chorhaupt wird errichtet.  
Die Pfeiler werden hierzu im Kreis angeordnet.

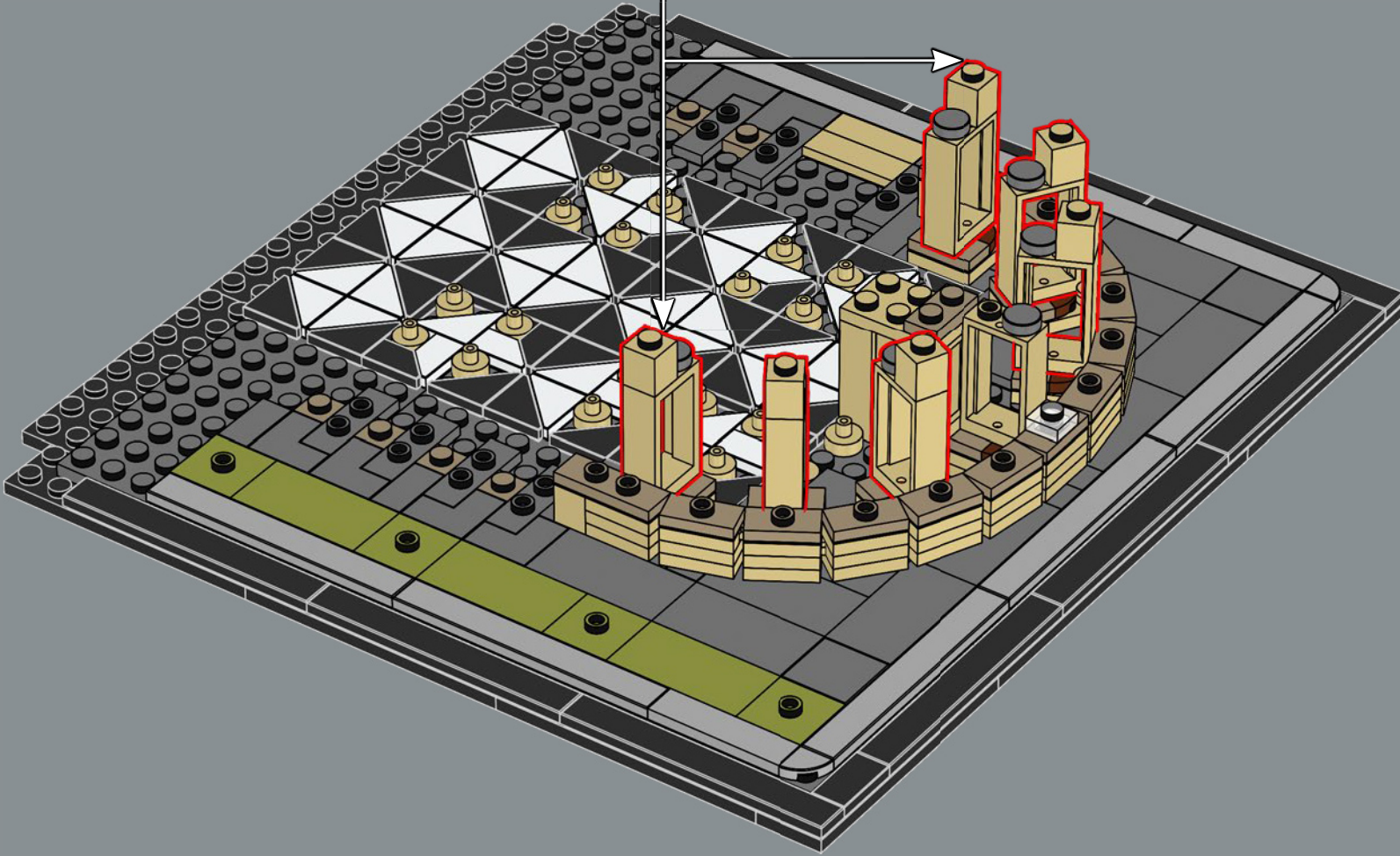





40

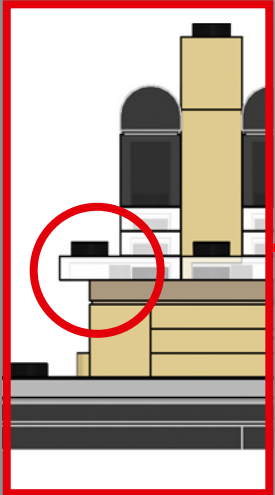
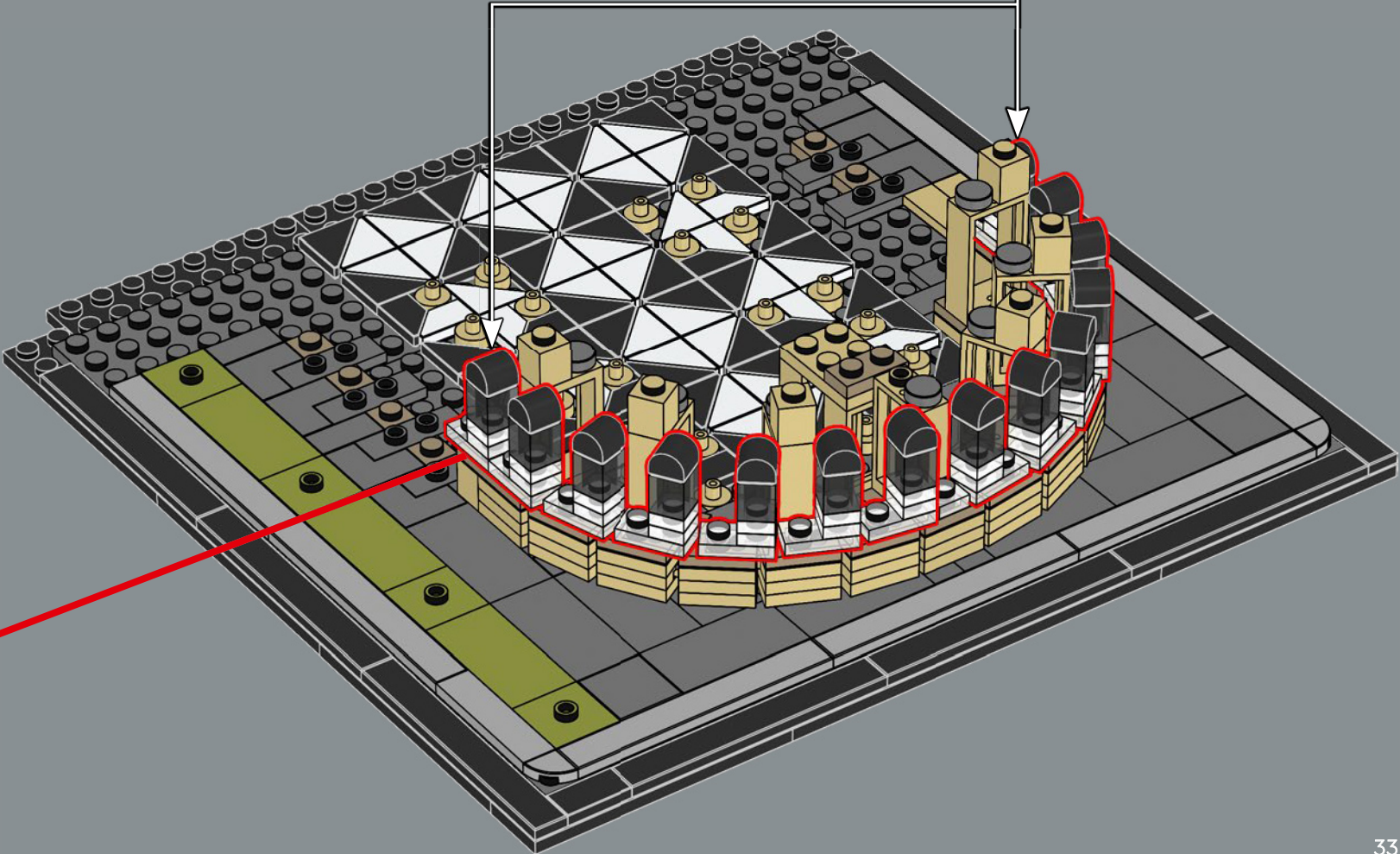
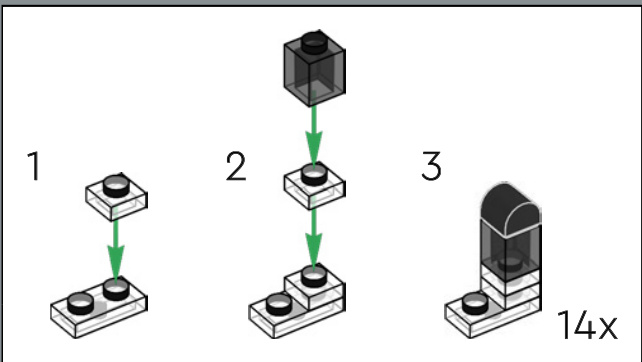

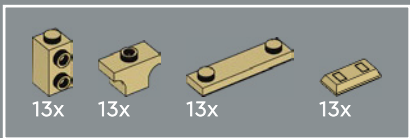

41

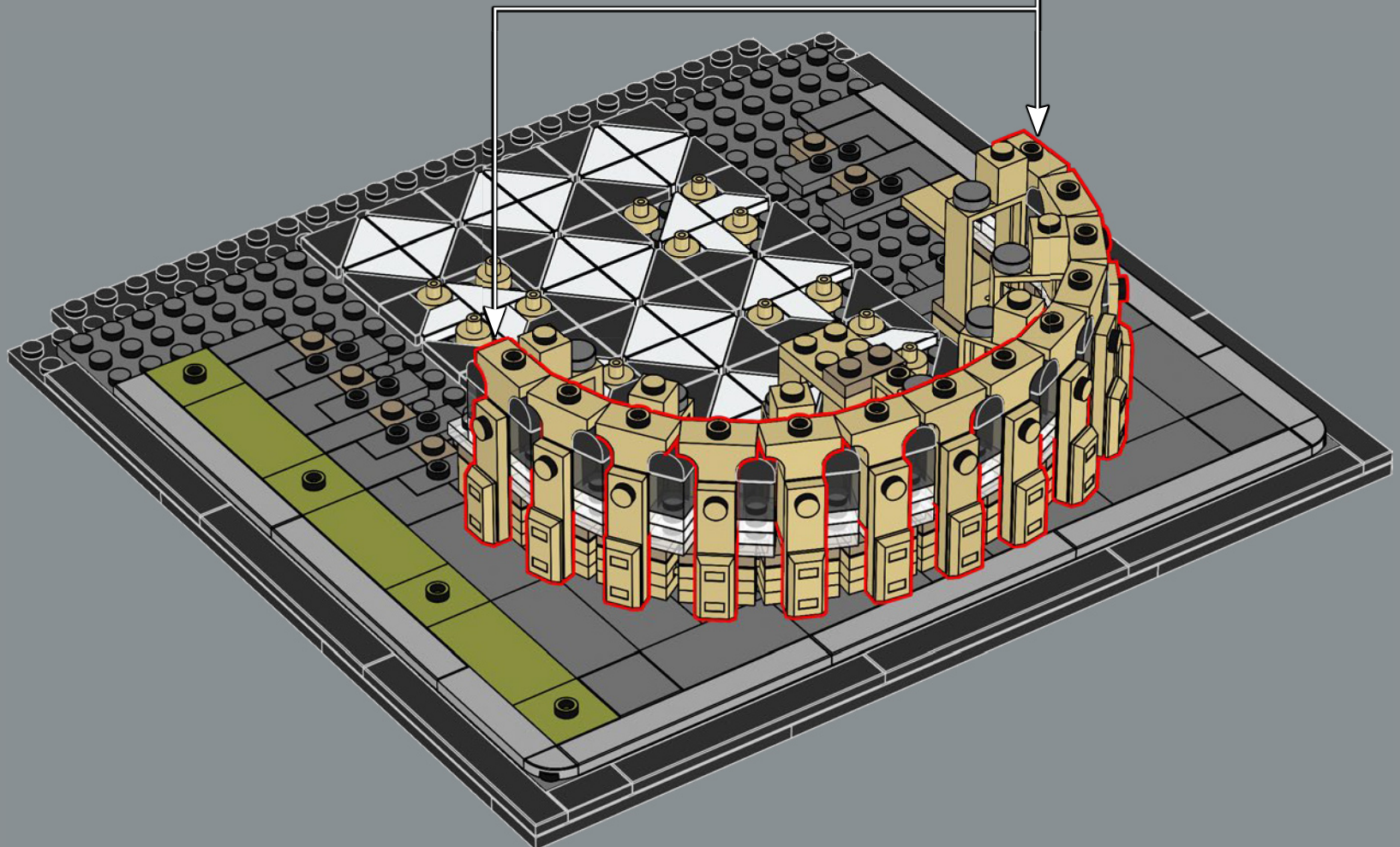
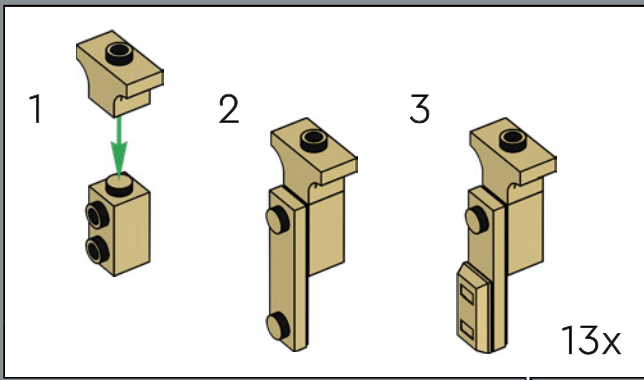

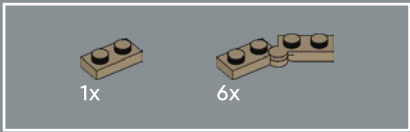

42

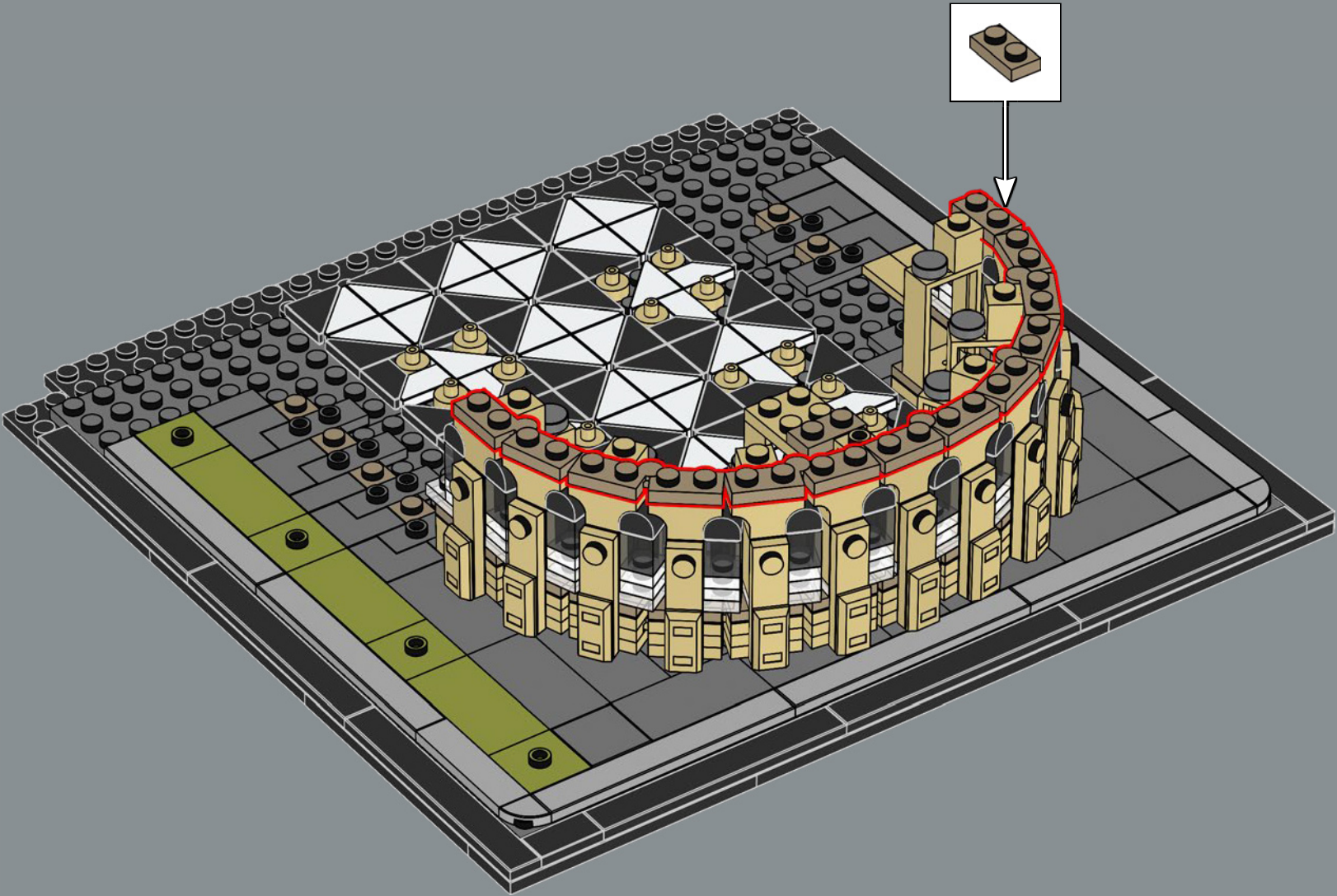

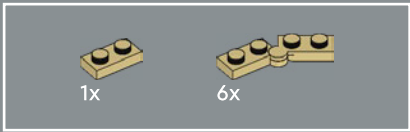

43

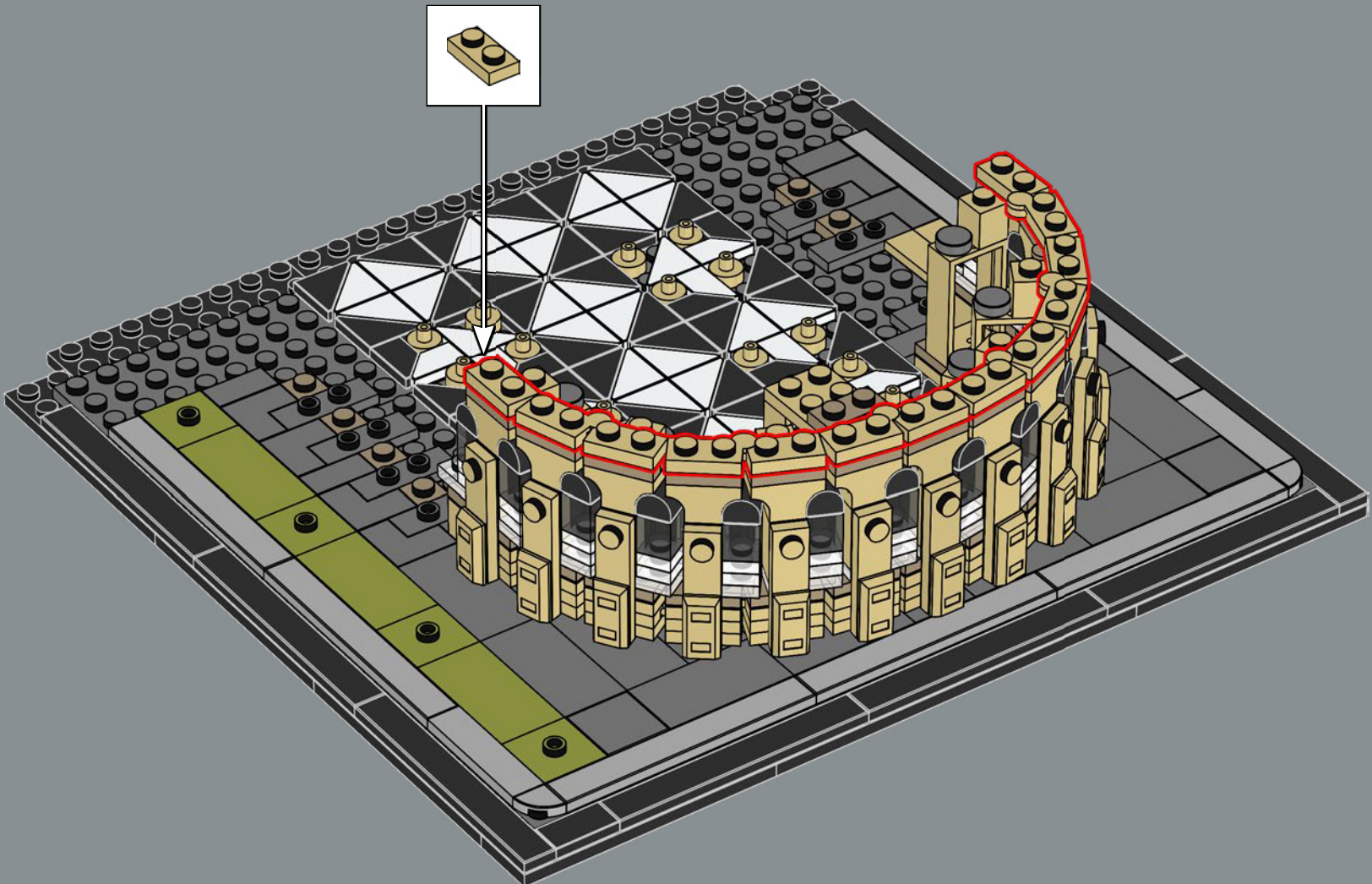

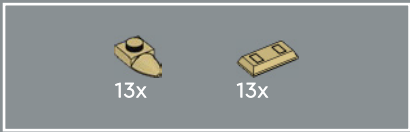

44

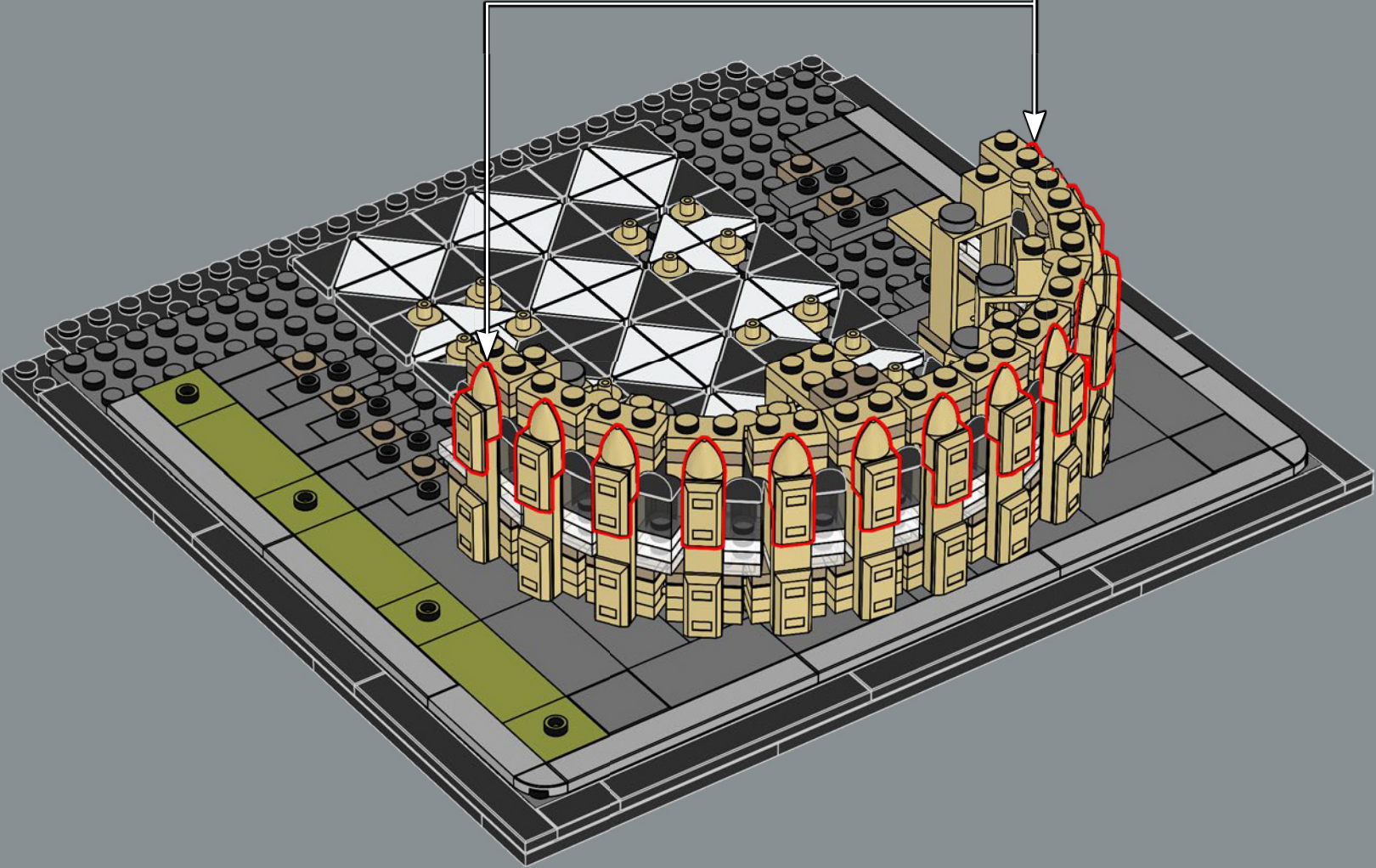
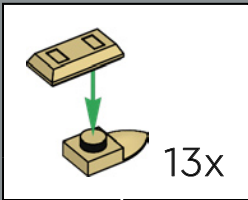

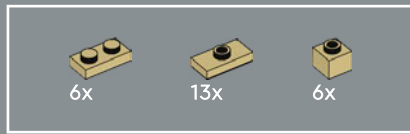

45

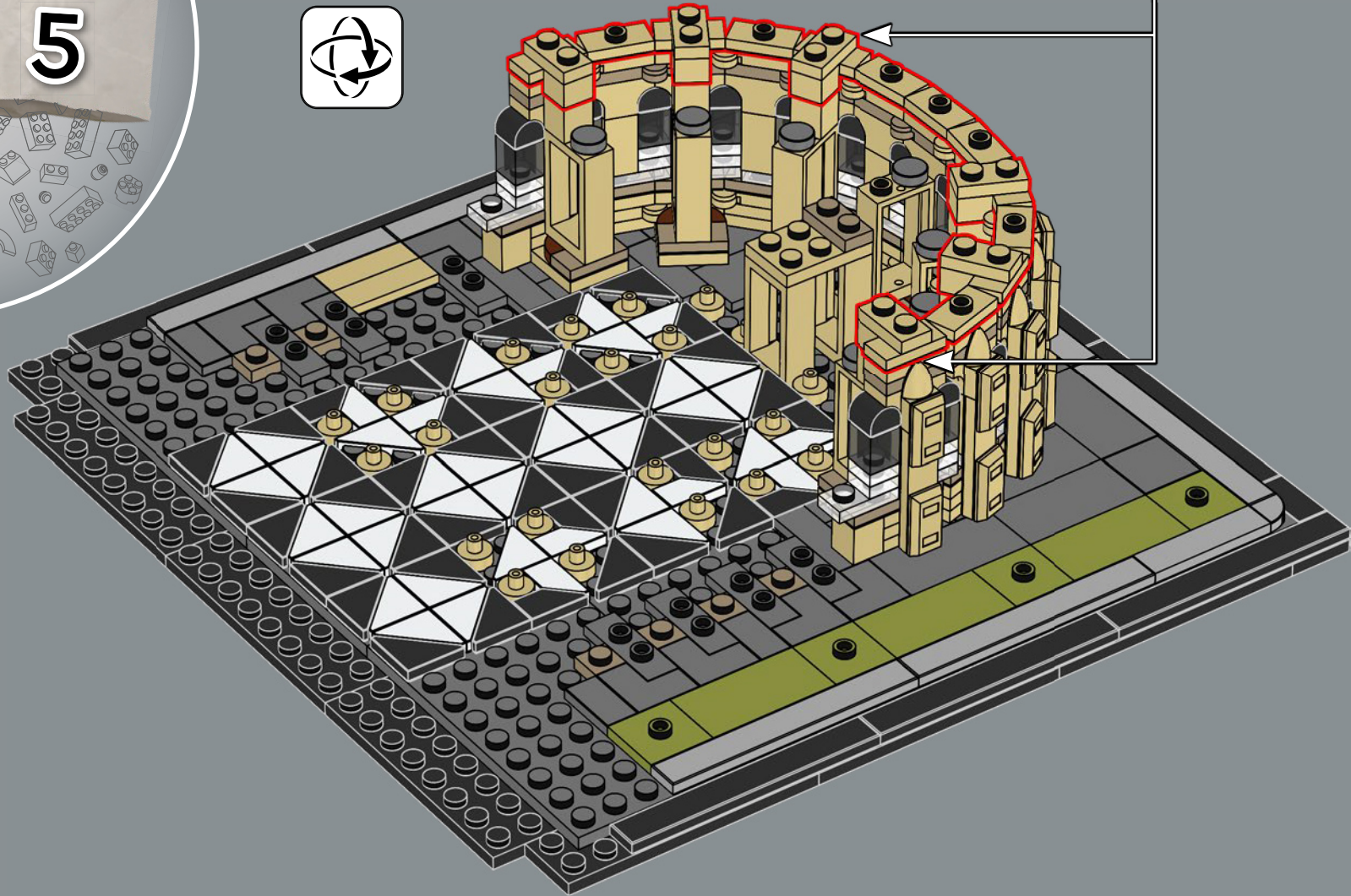
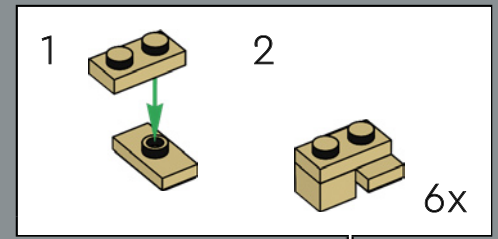

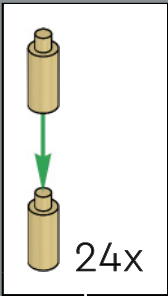

46

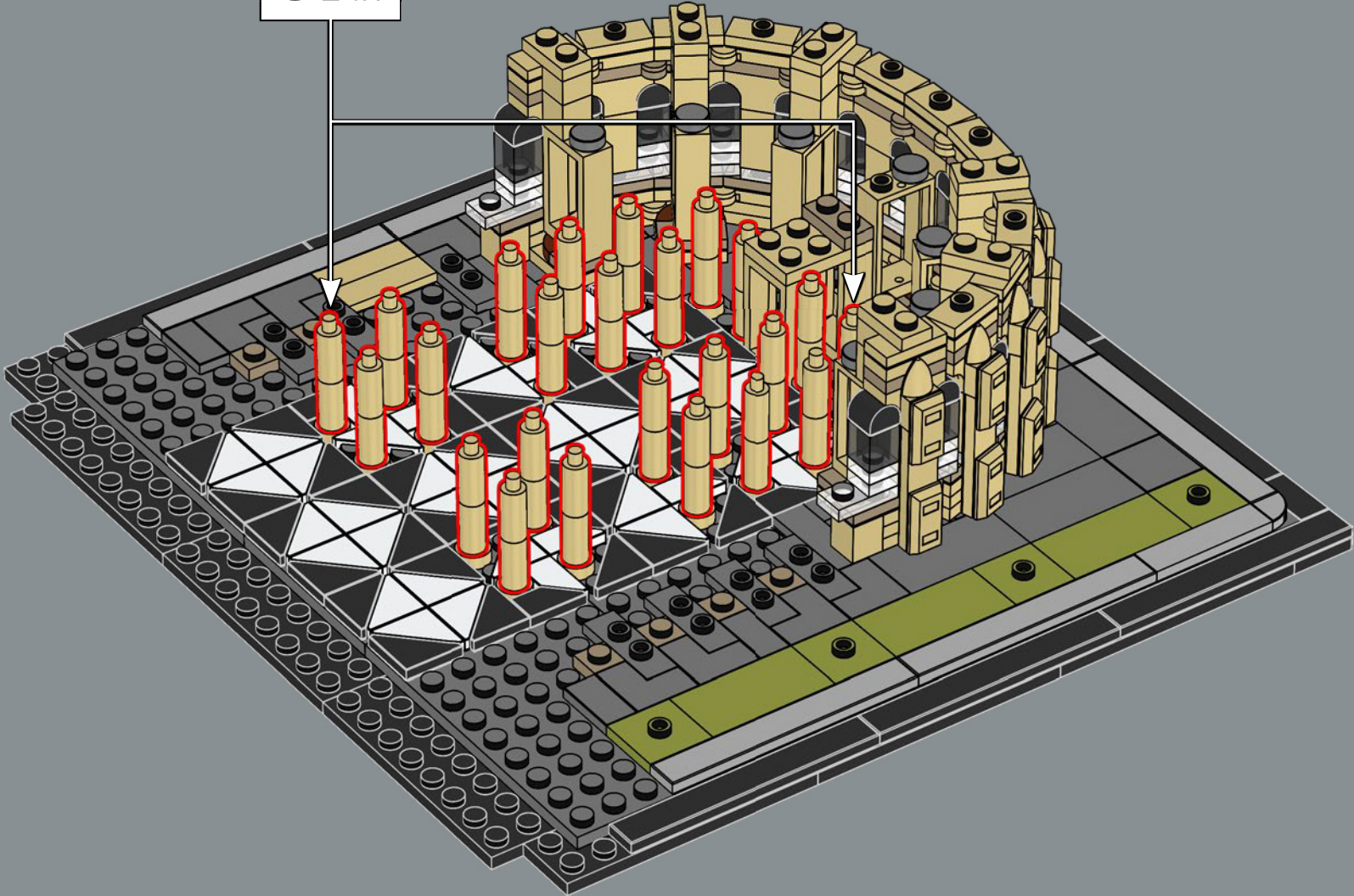

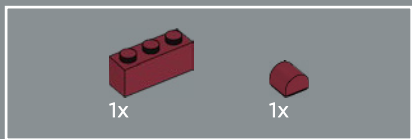

47

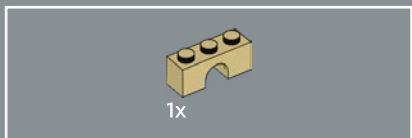
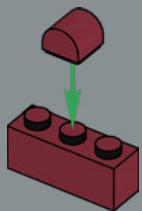

48

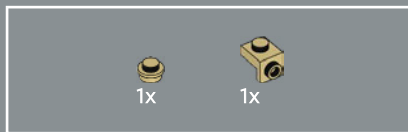
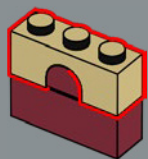

49

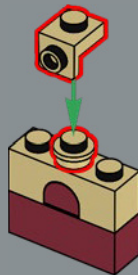

50

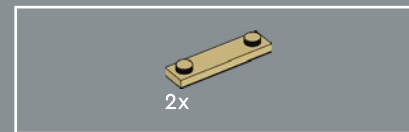
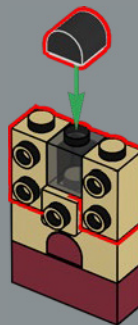

51

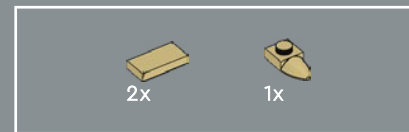

52

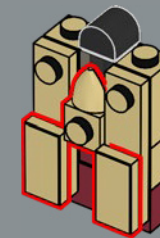



Ein elegantes Portal bietet direkten Zugang zum Chor.  
La Porte Rouge verdankt ihren Namen der roten Farbe der  
Türscheiben. Das Portal wurde um das Jahr 1270 renoviert.

53

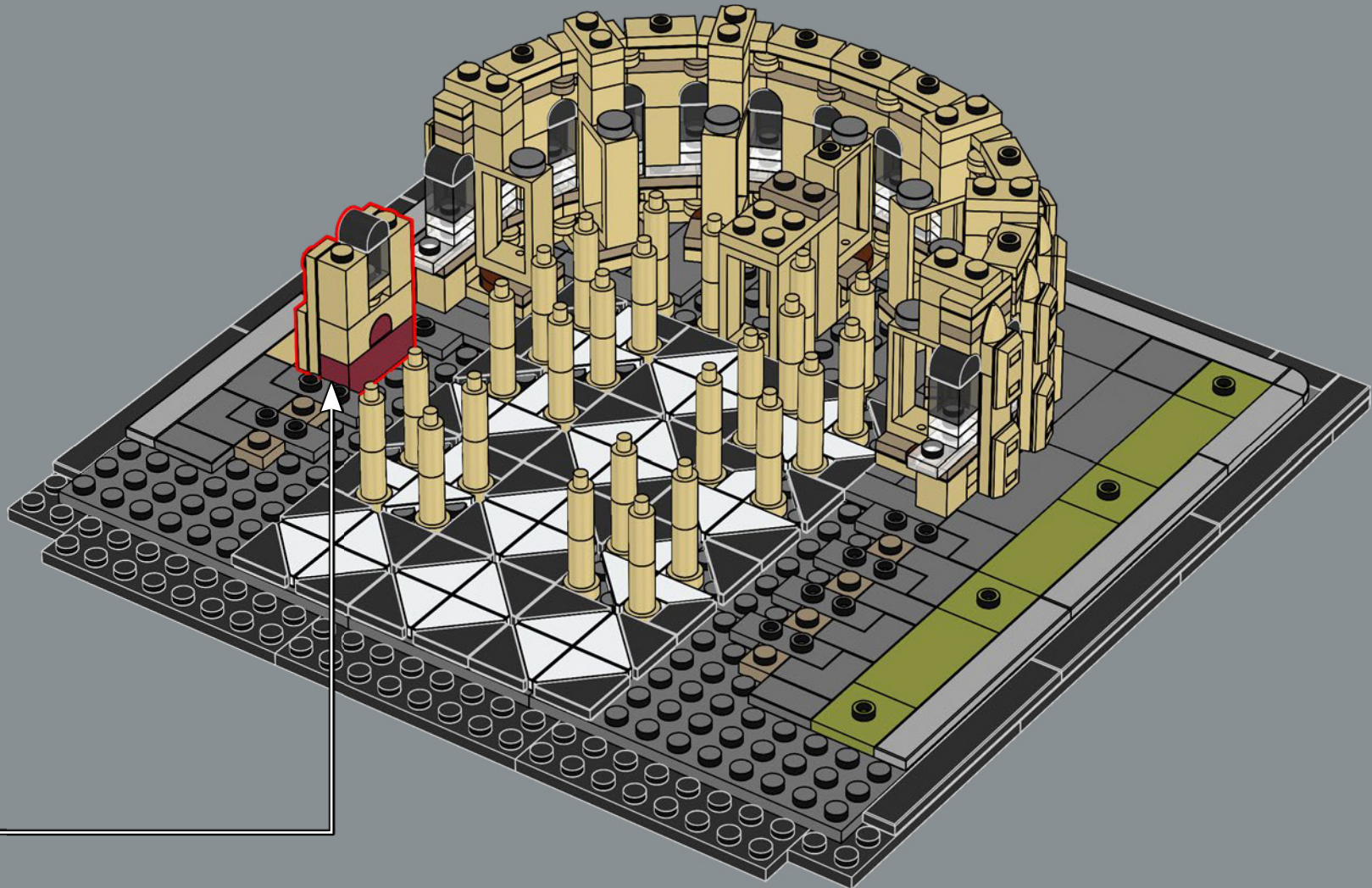

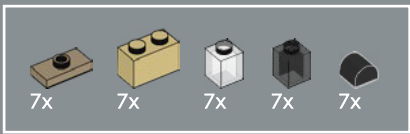

54

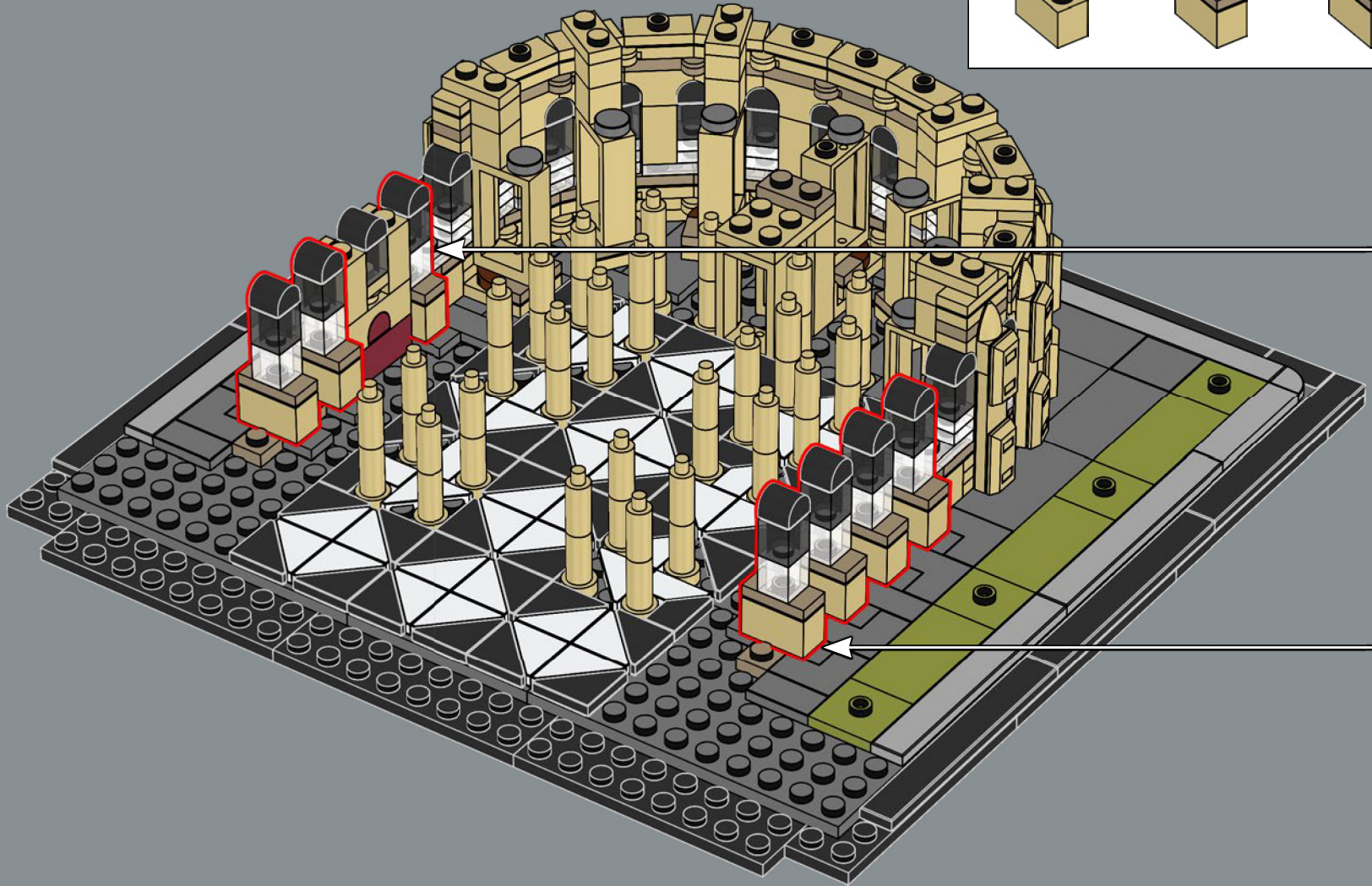
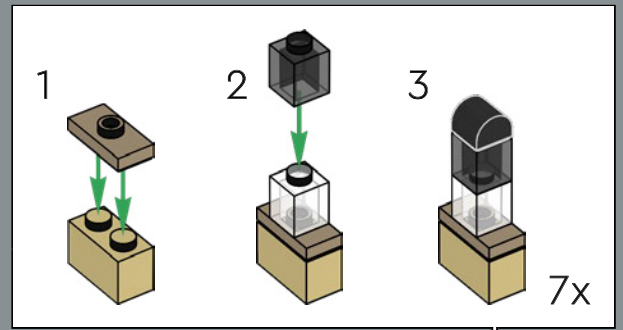

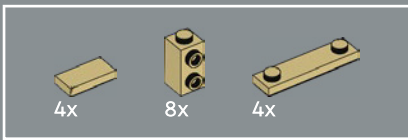

55

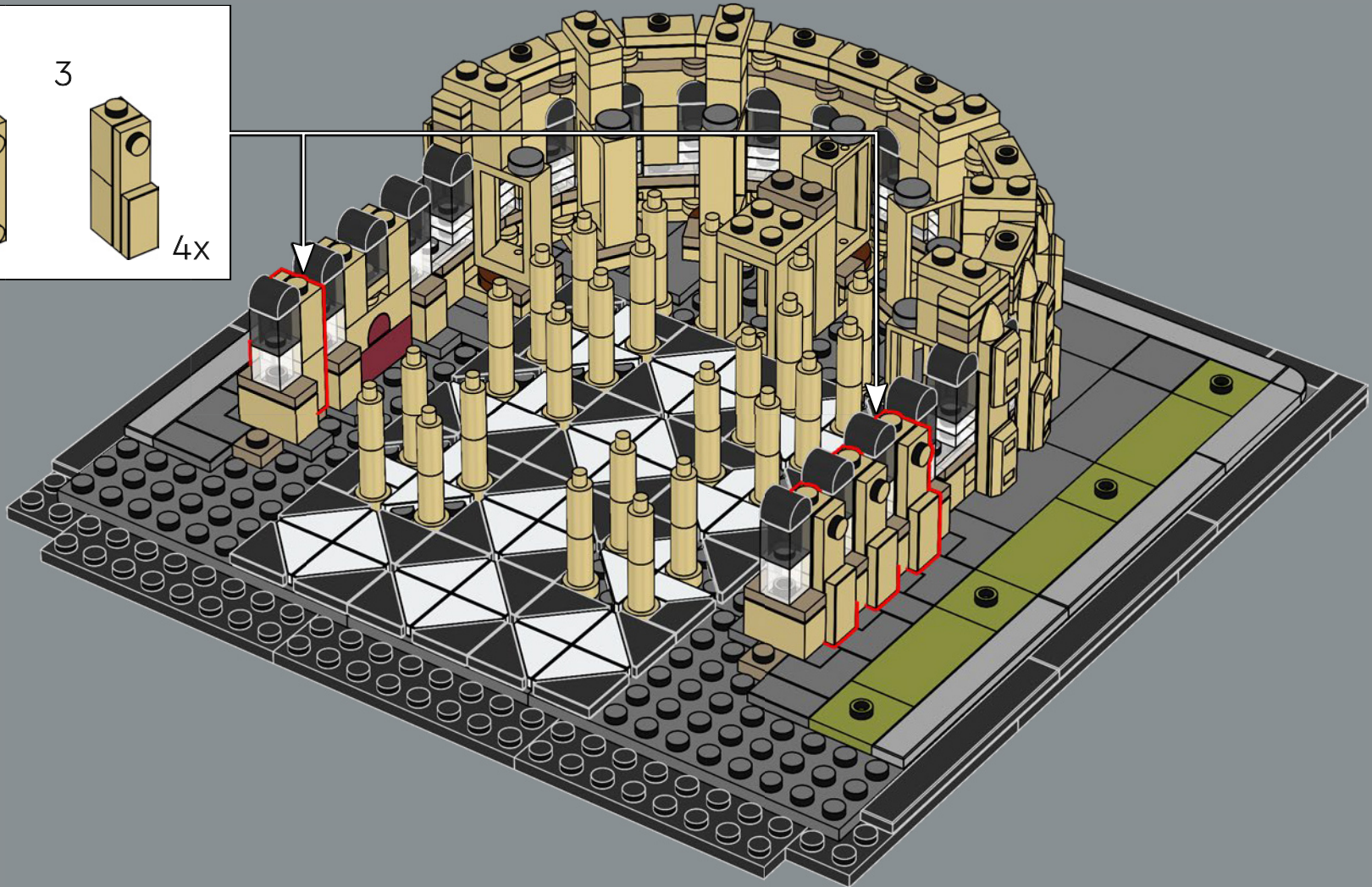
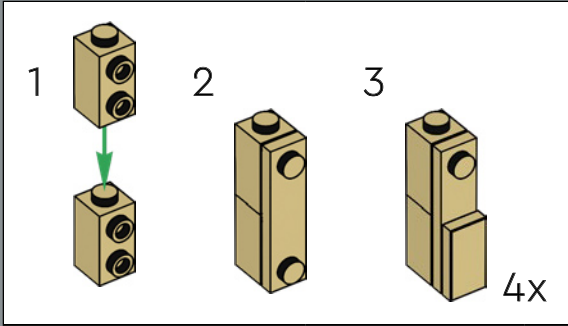

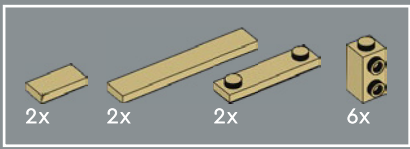

56

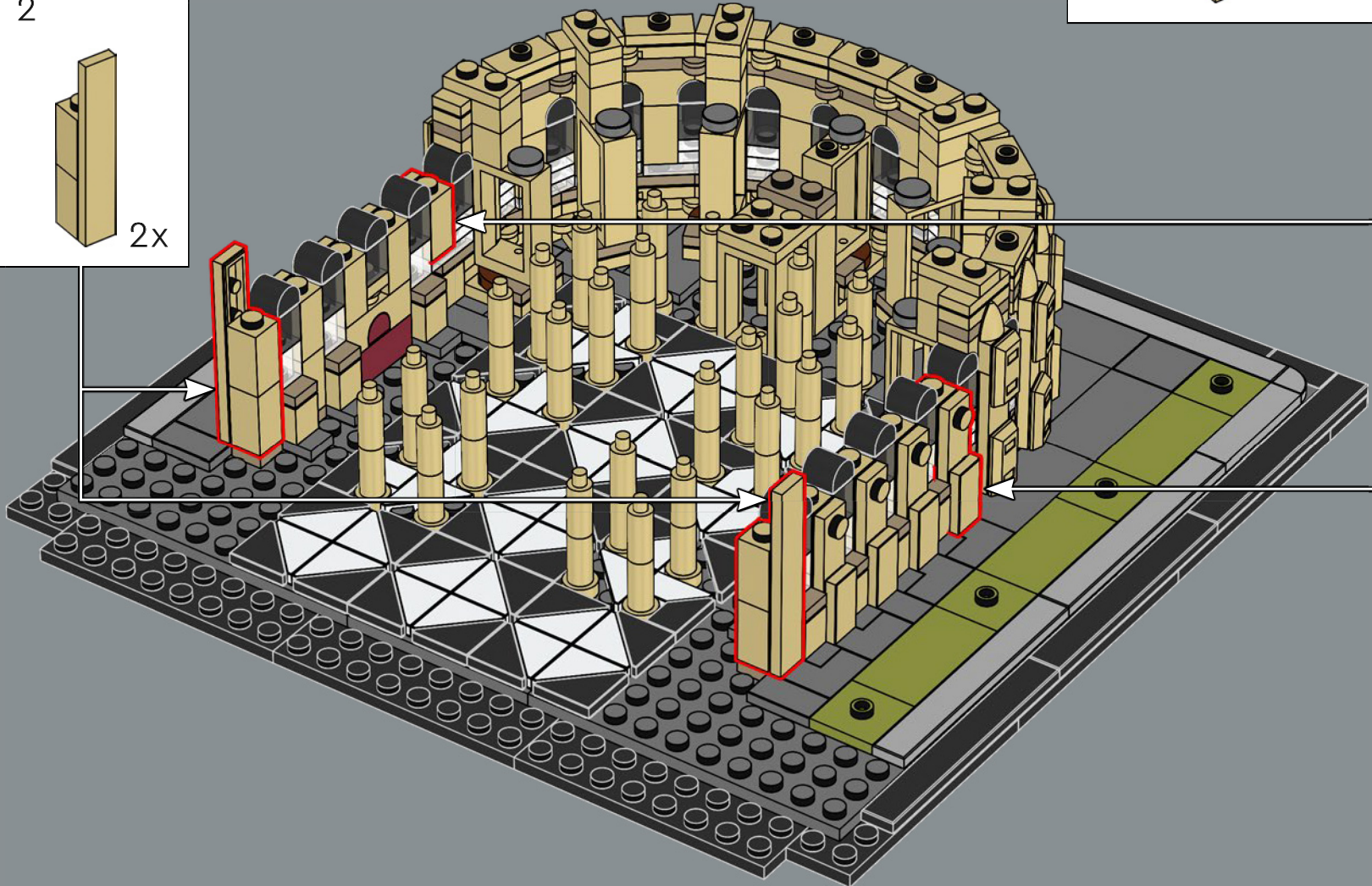
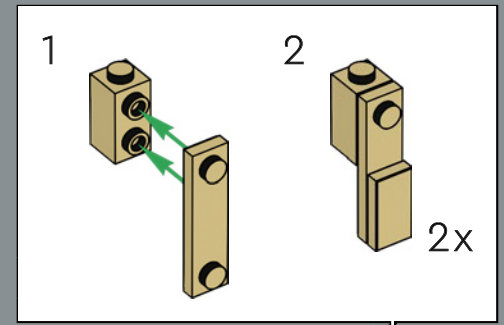
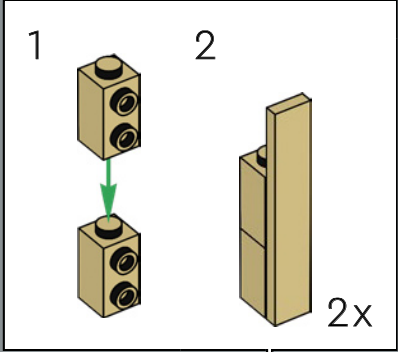

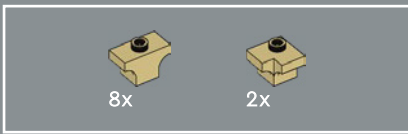

57

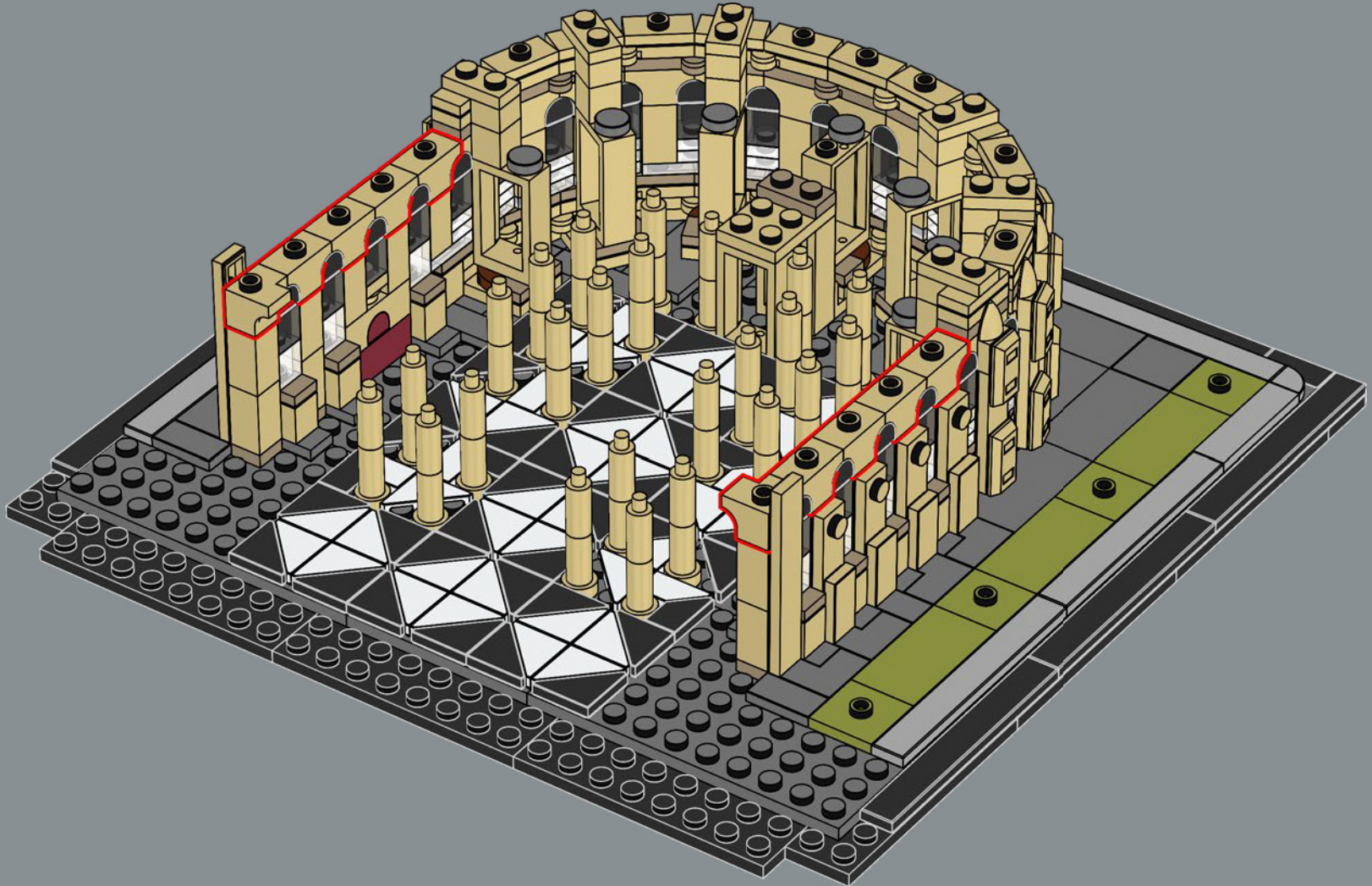

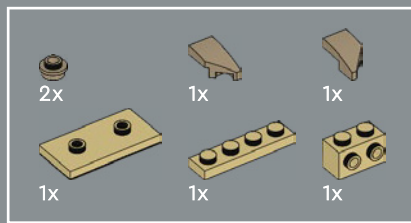

58

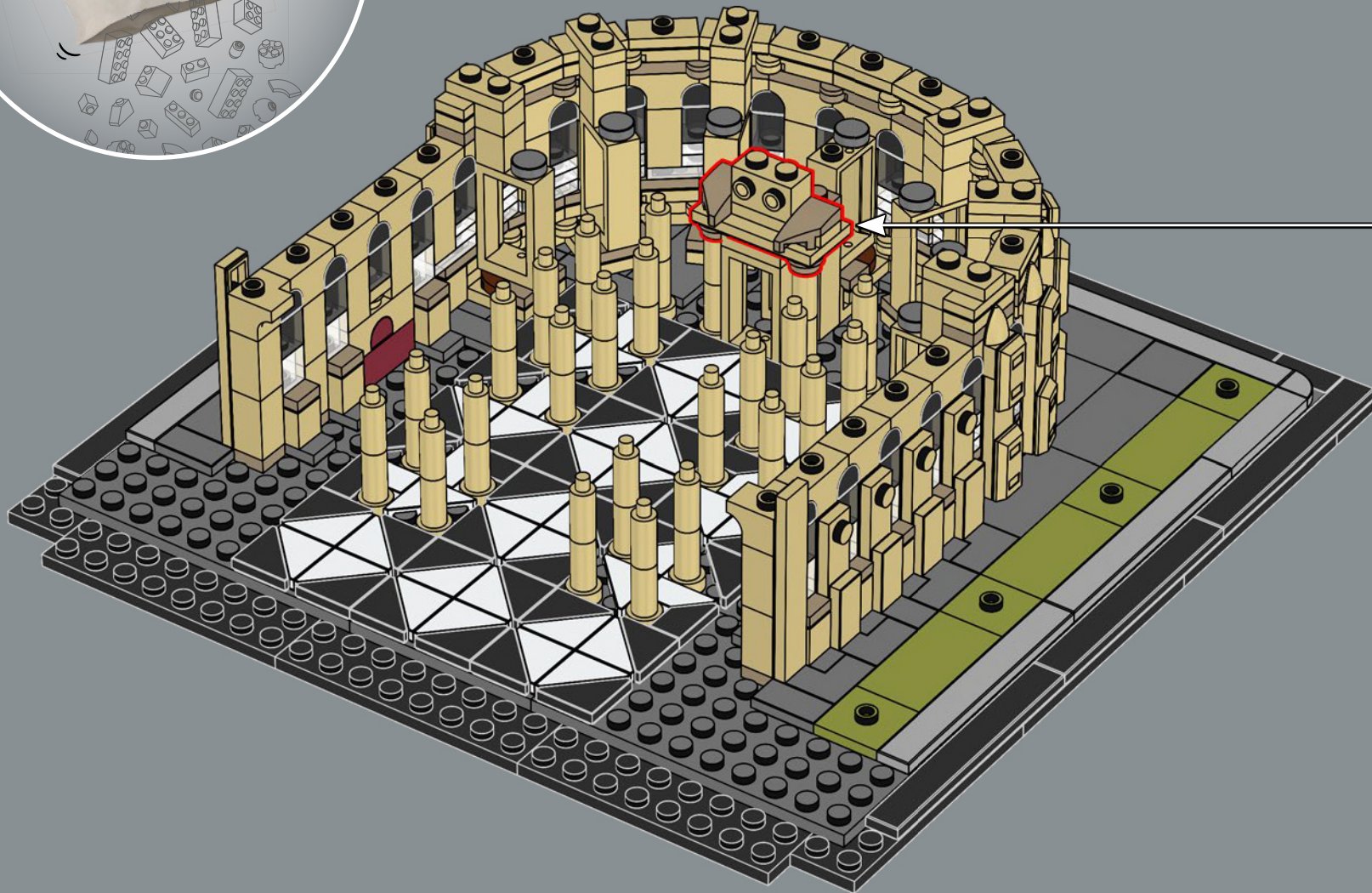
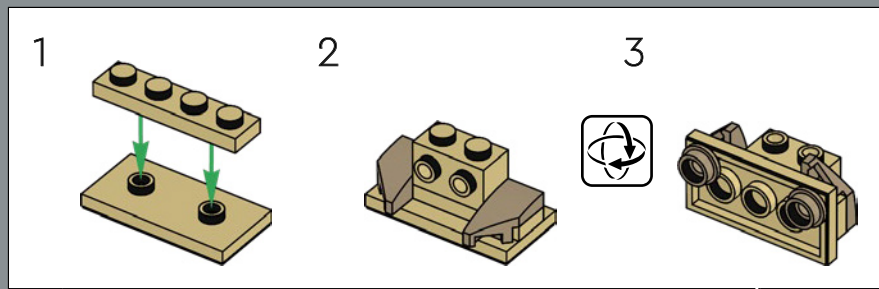

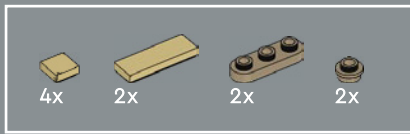

59

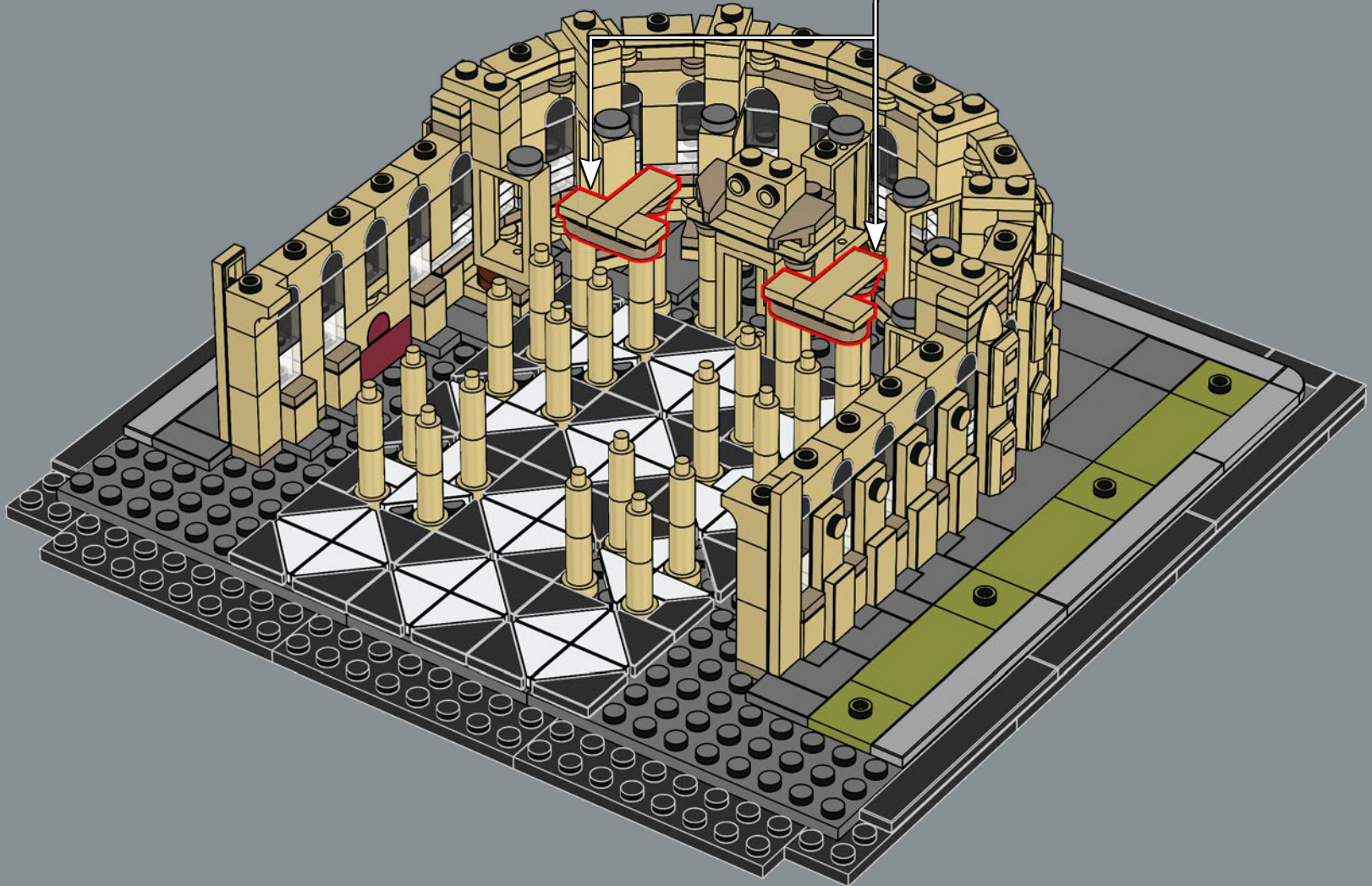
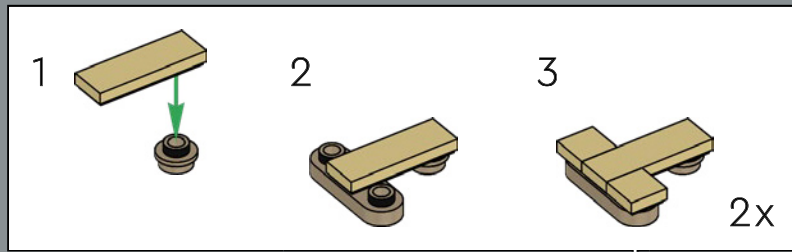

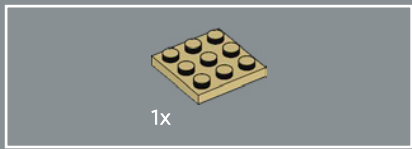

1x

60

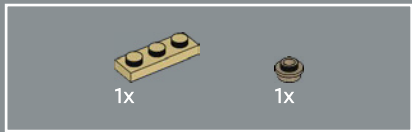
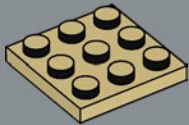

1x

1x

61

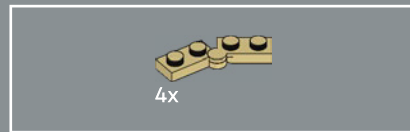
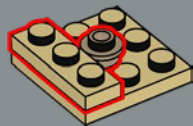

4x

62

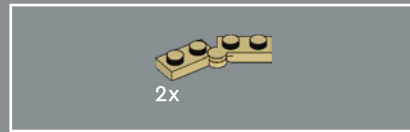
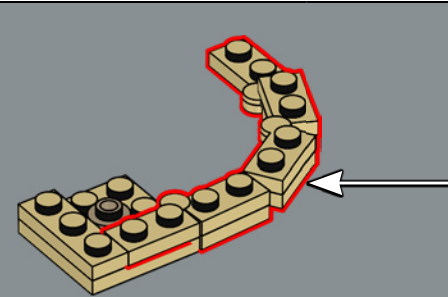
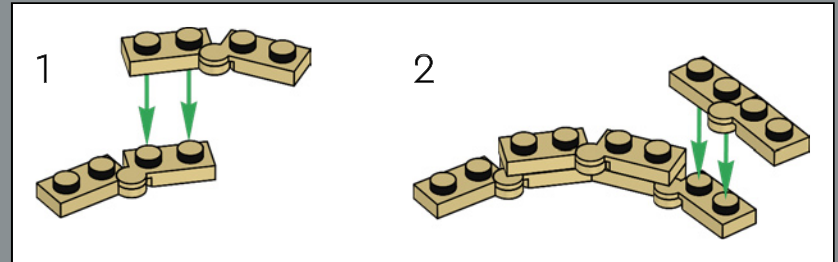

2x

63

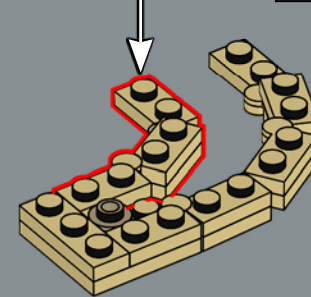
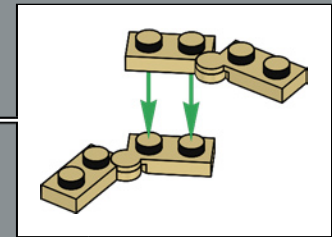





64

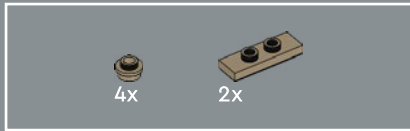
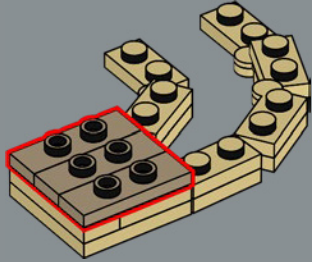

65

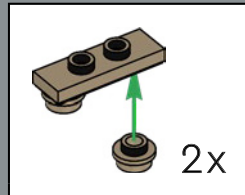
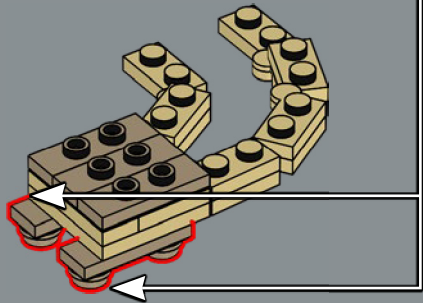

66

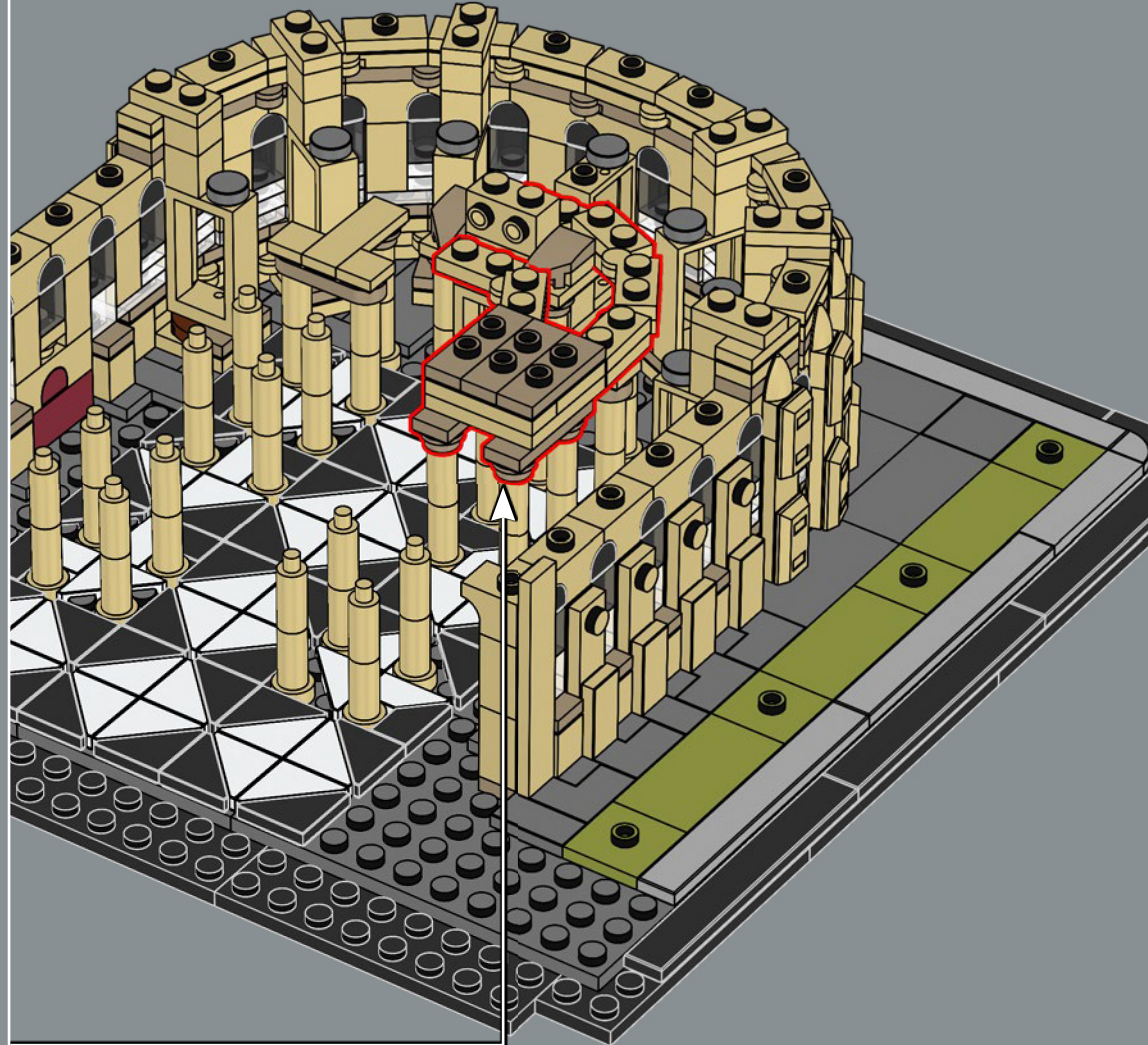

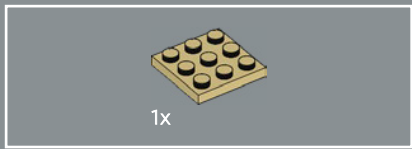

67

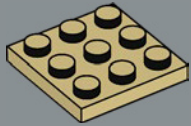

68

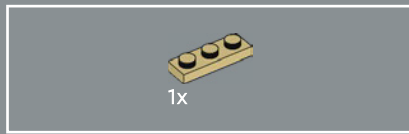
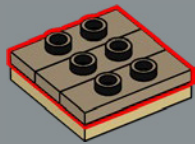

69

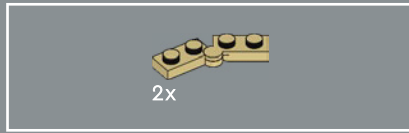
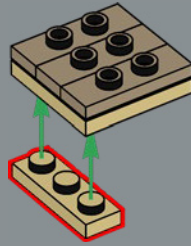

70

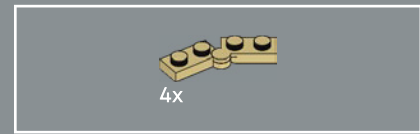
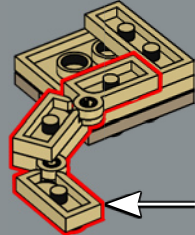
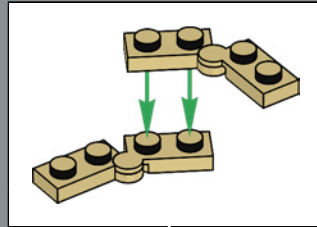

71

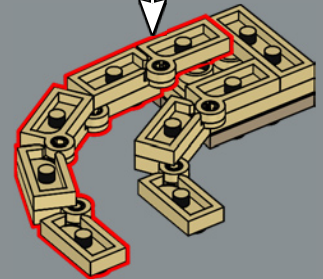
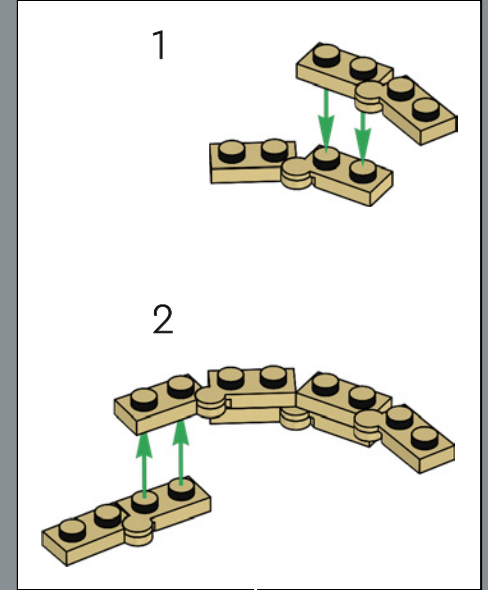

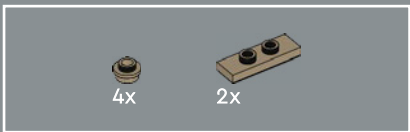

72

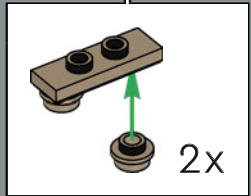
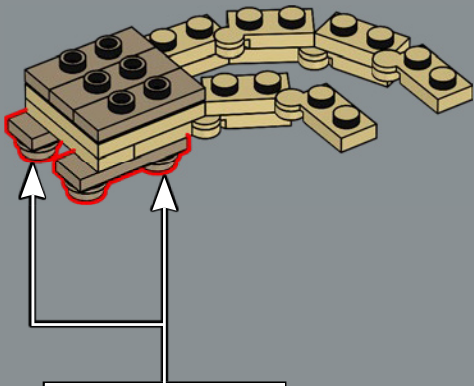

73

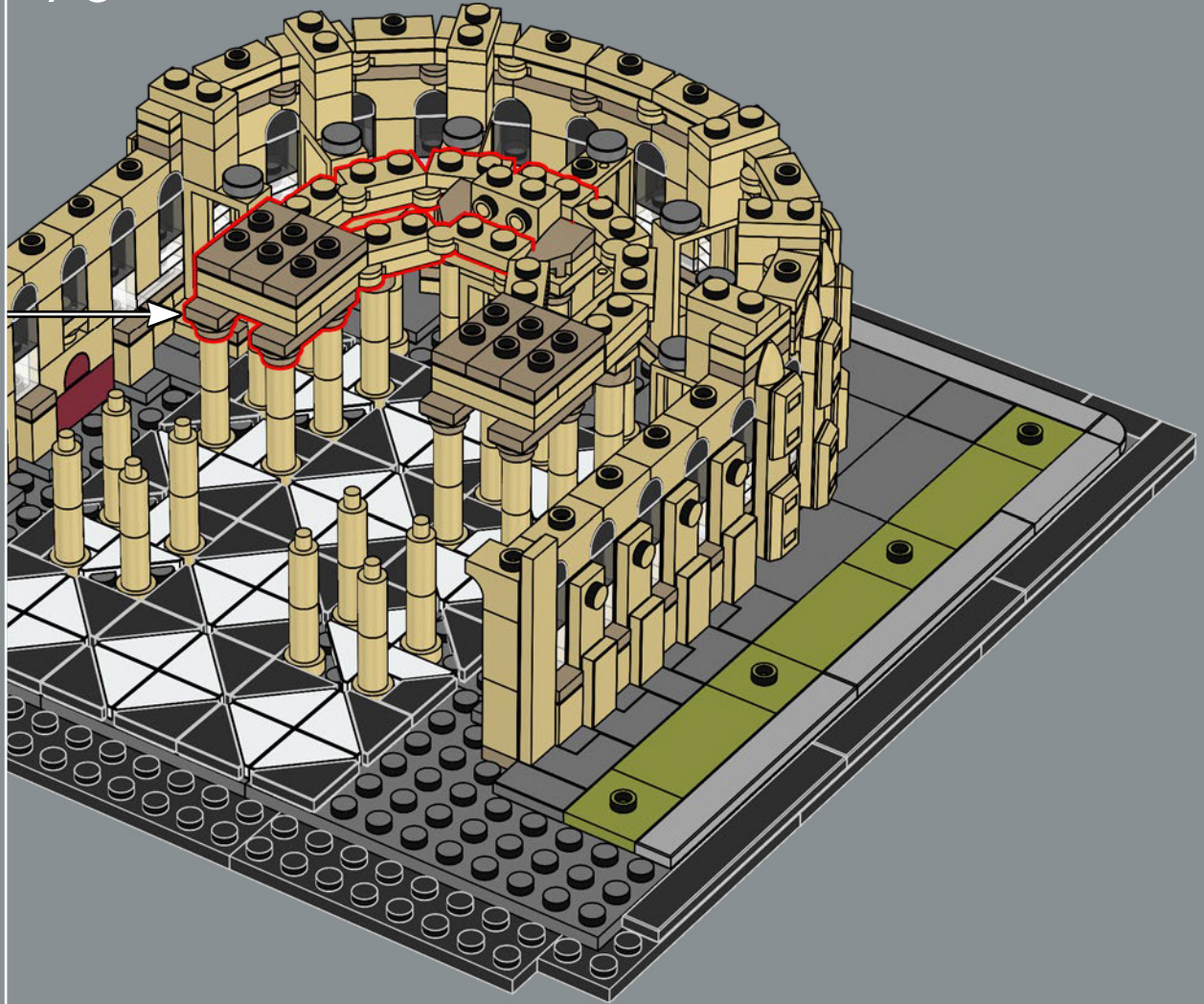

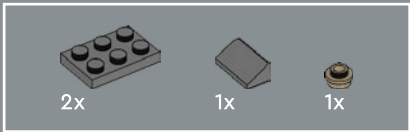

74

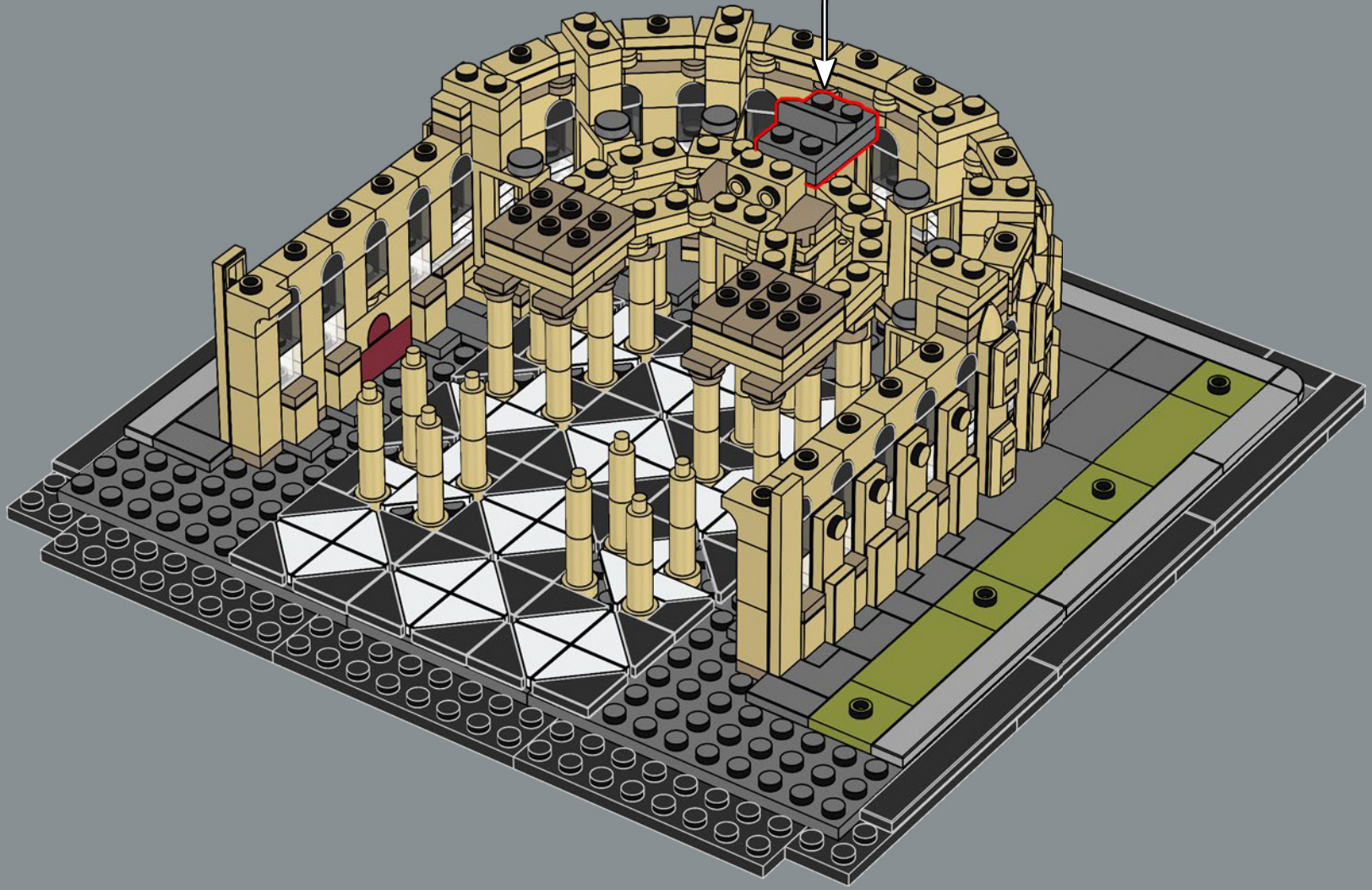
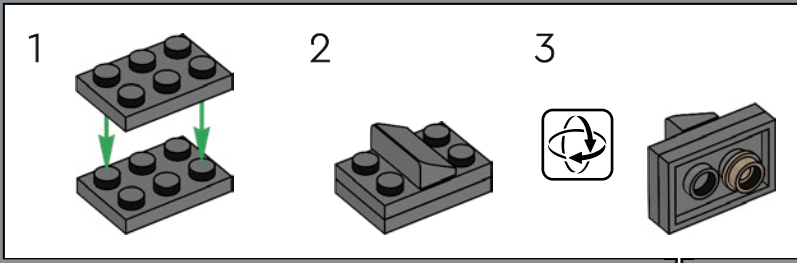

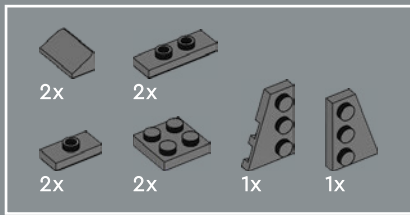

75

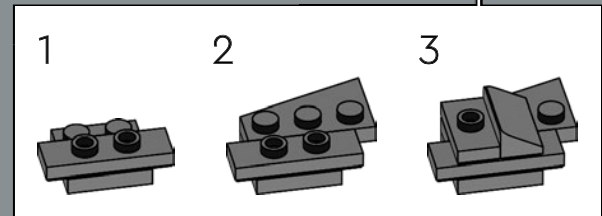
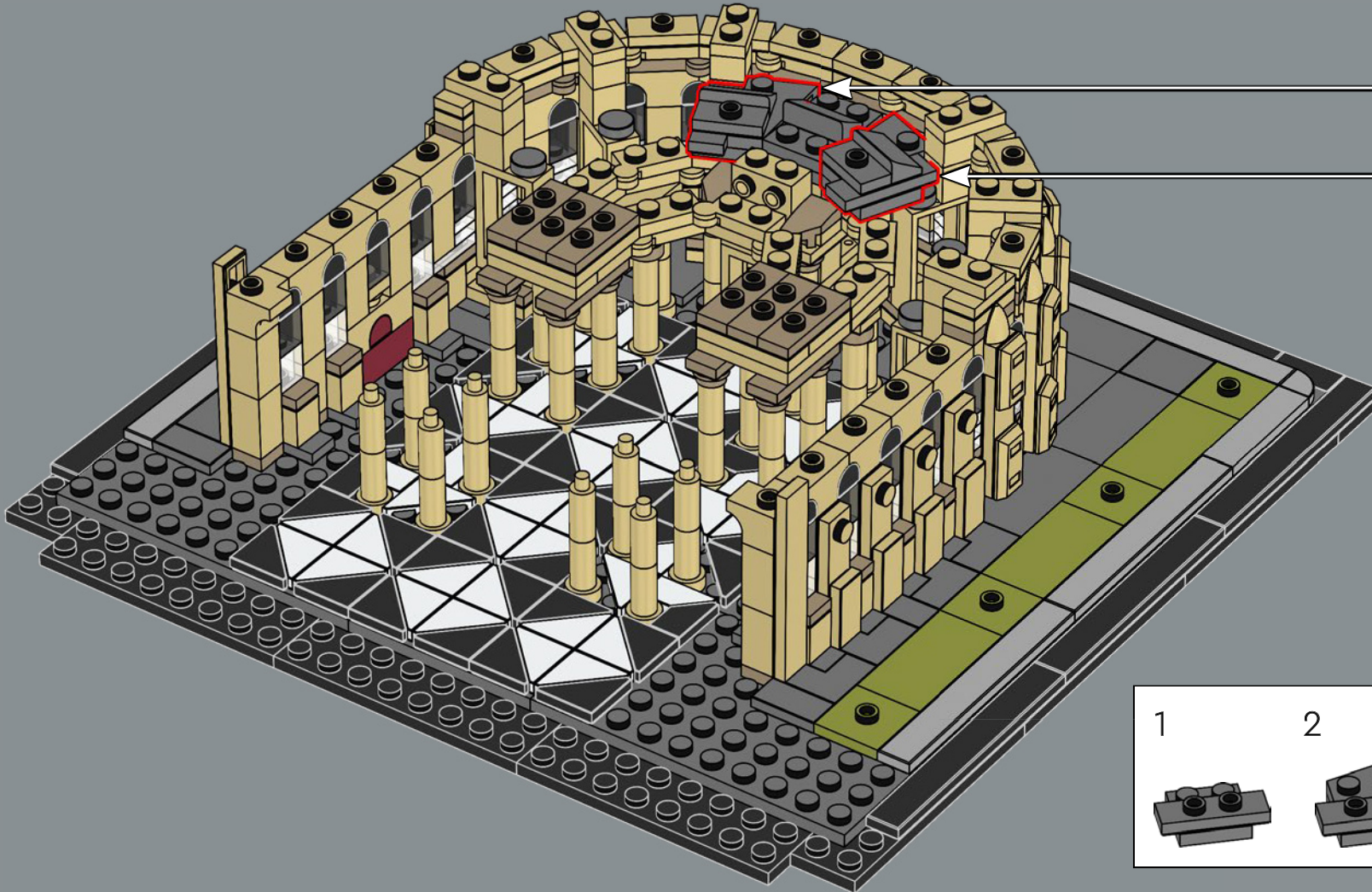
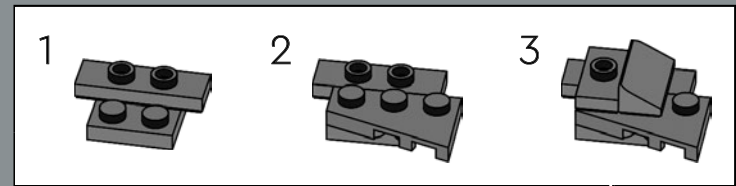

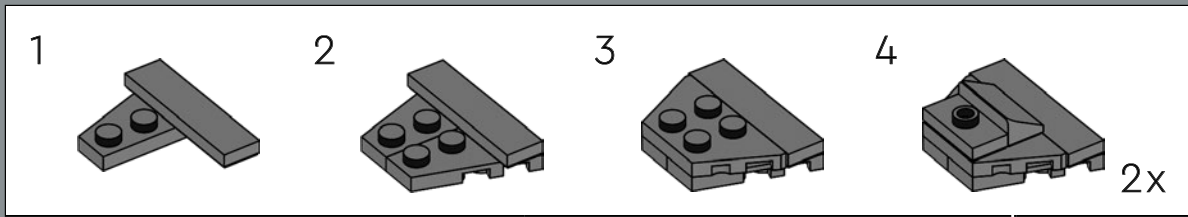
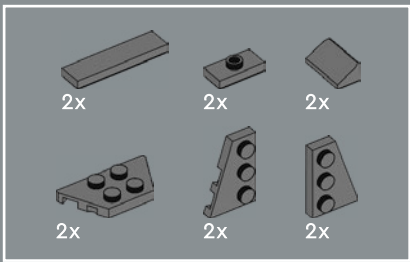

76

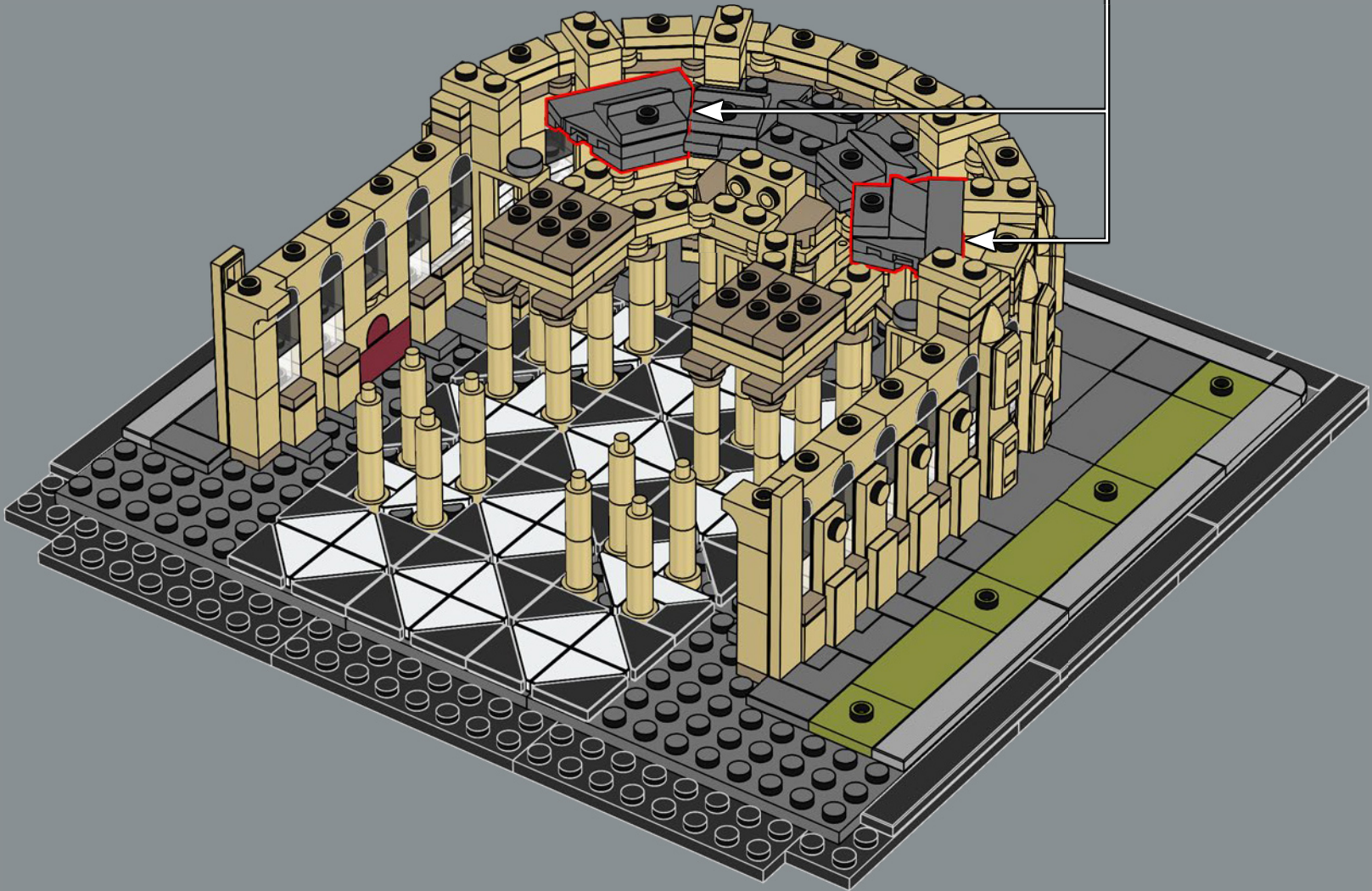

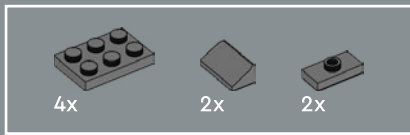

77

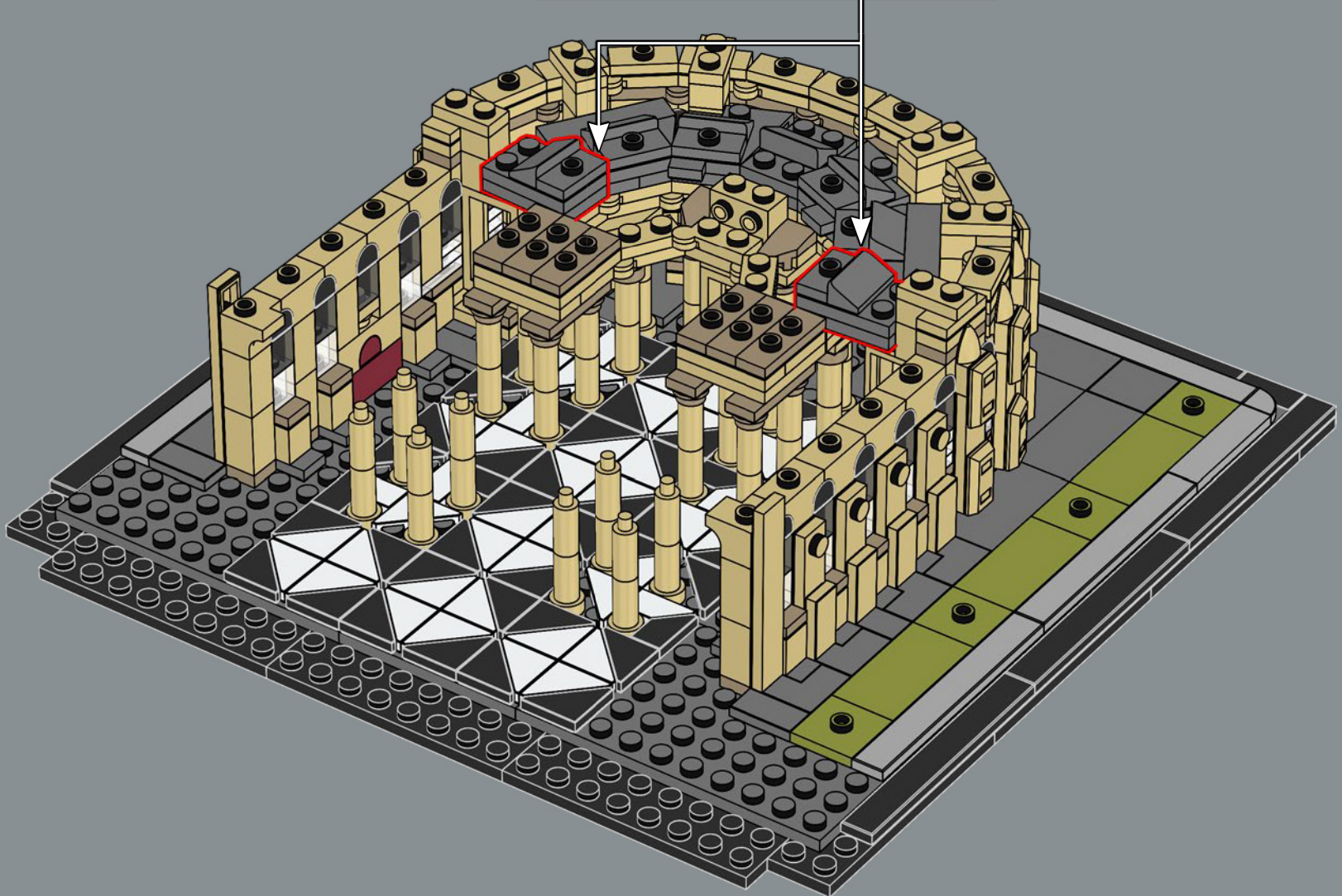
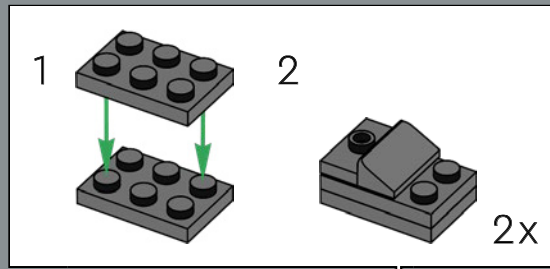



78

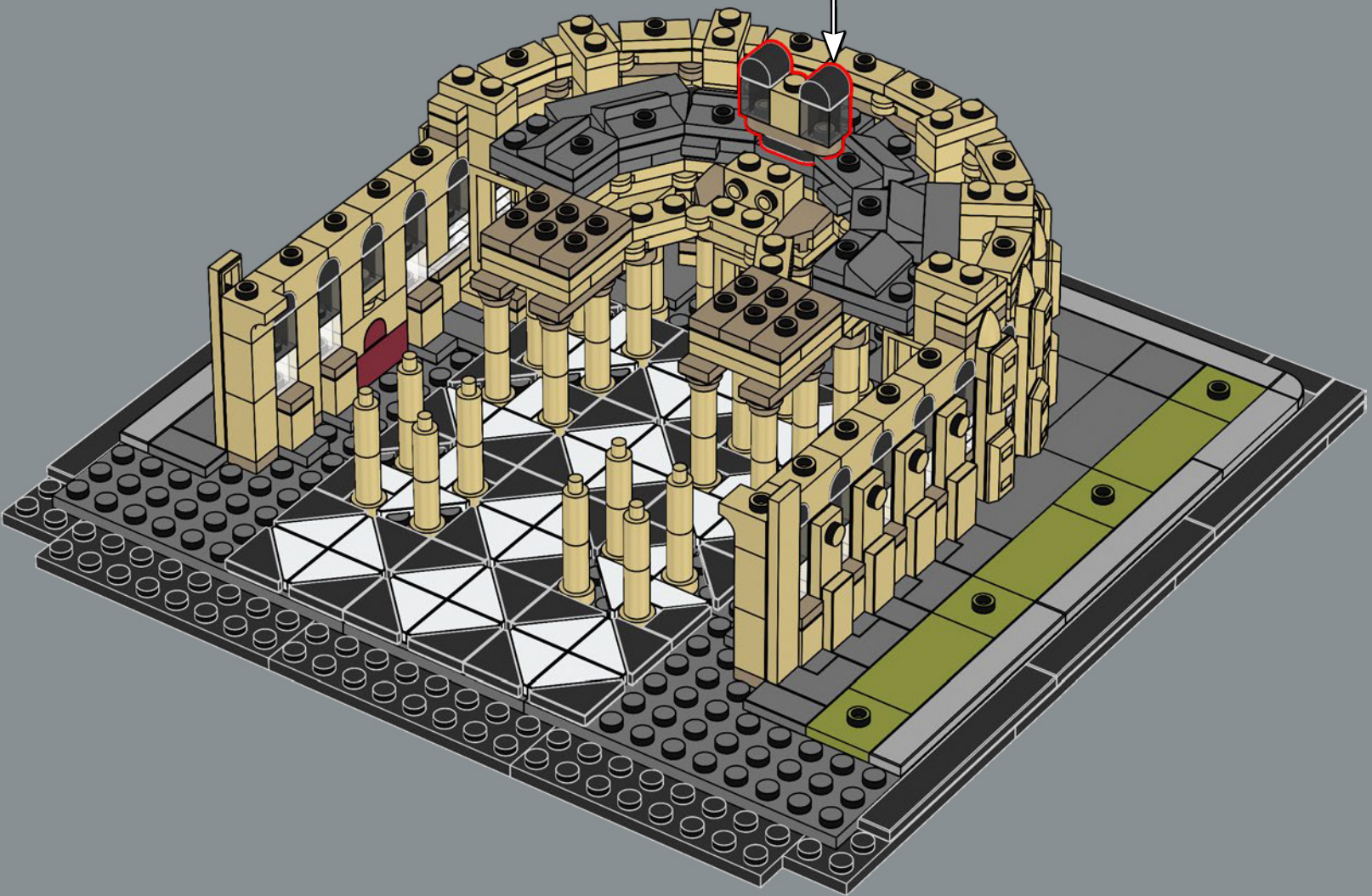
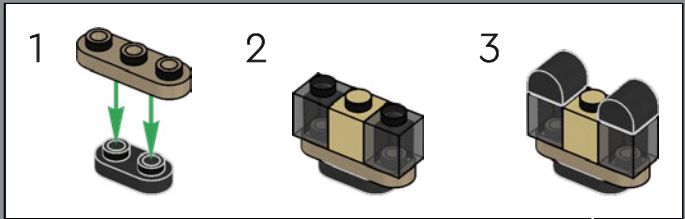





79

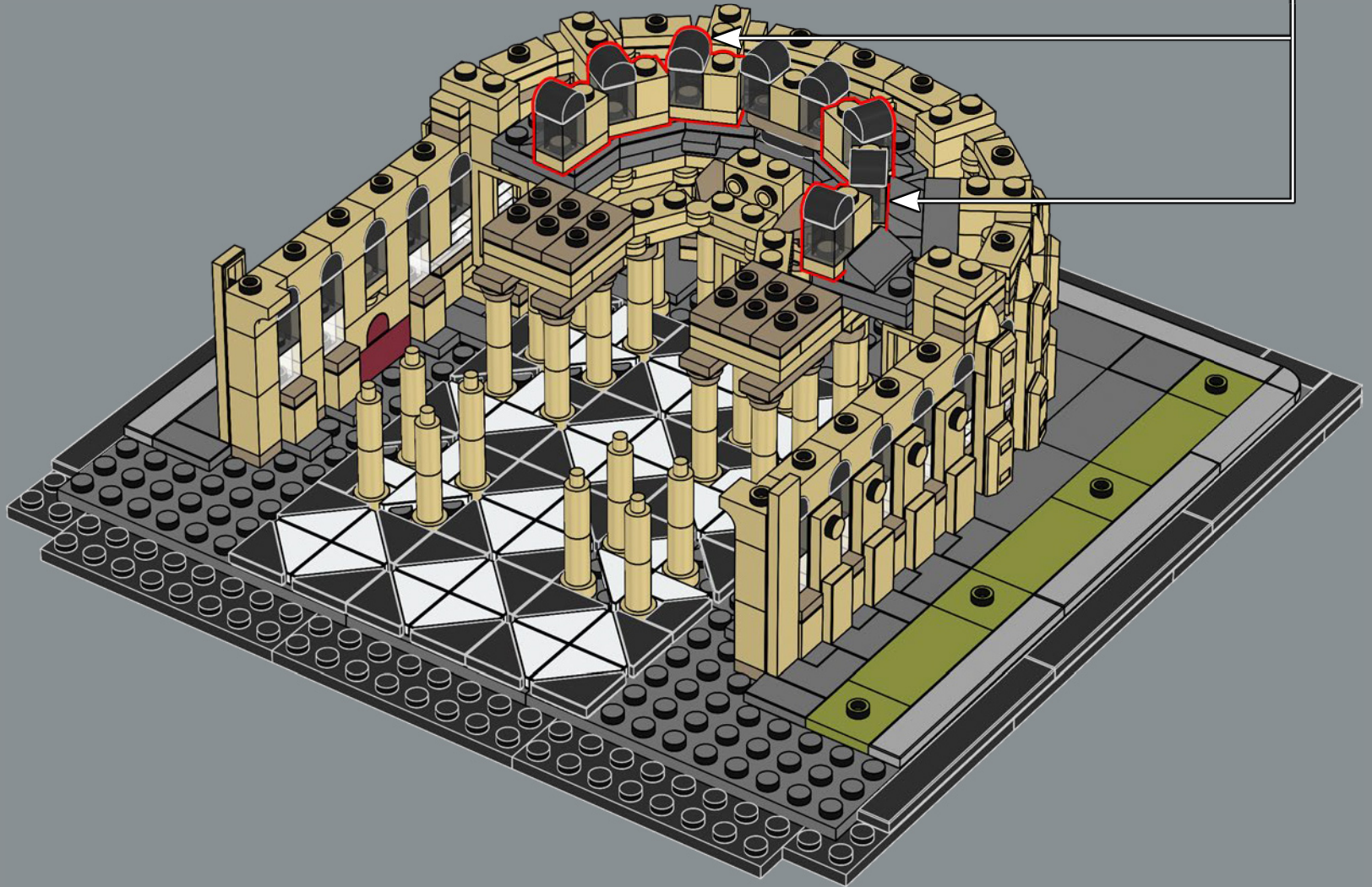
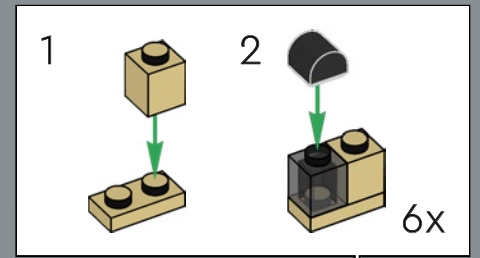



7x

80

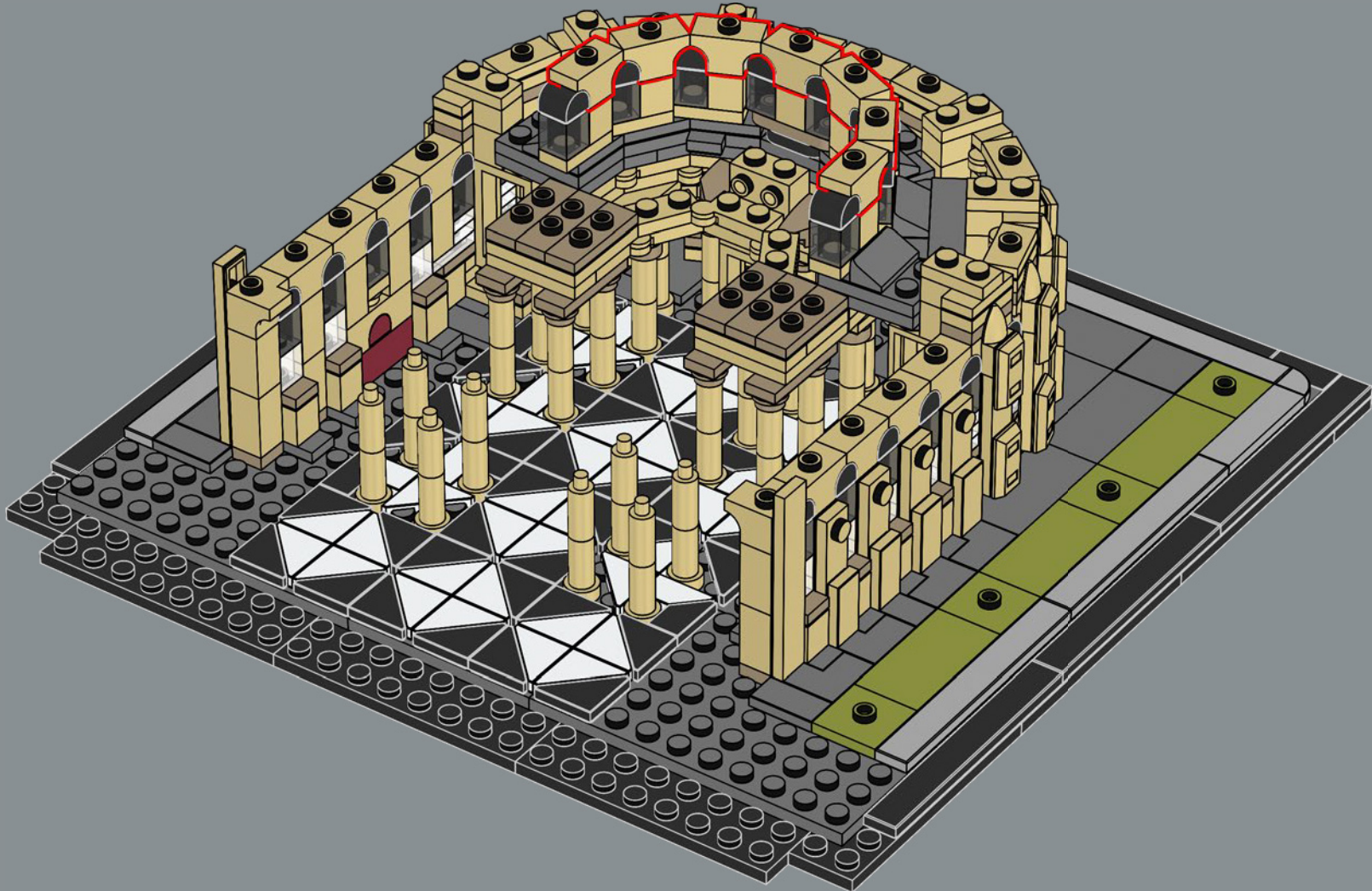

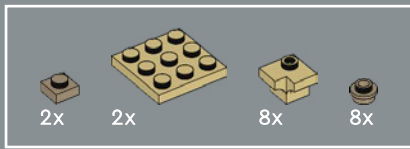

81

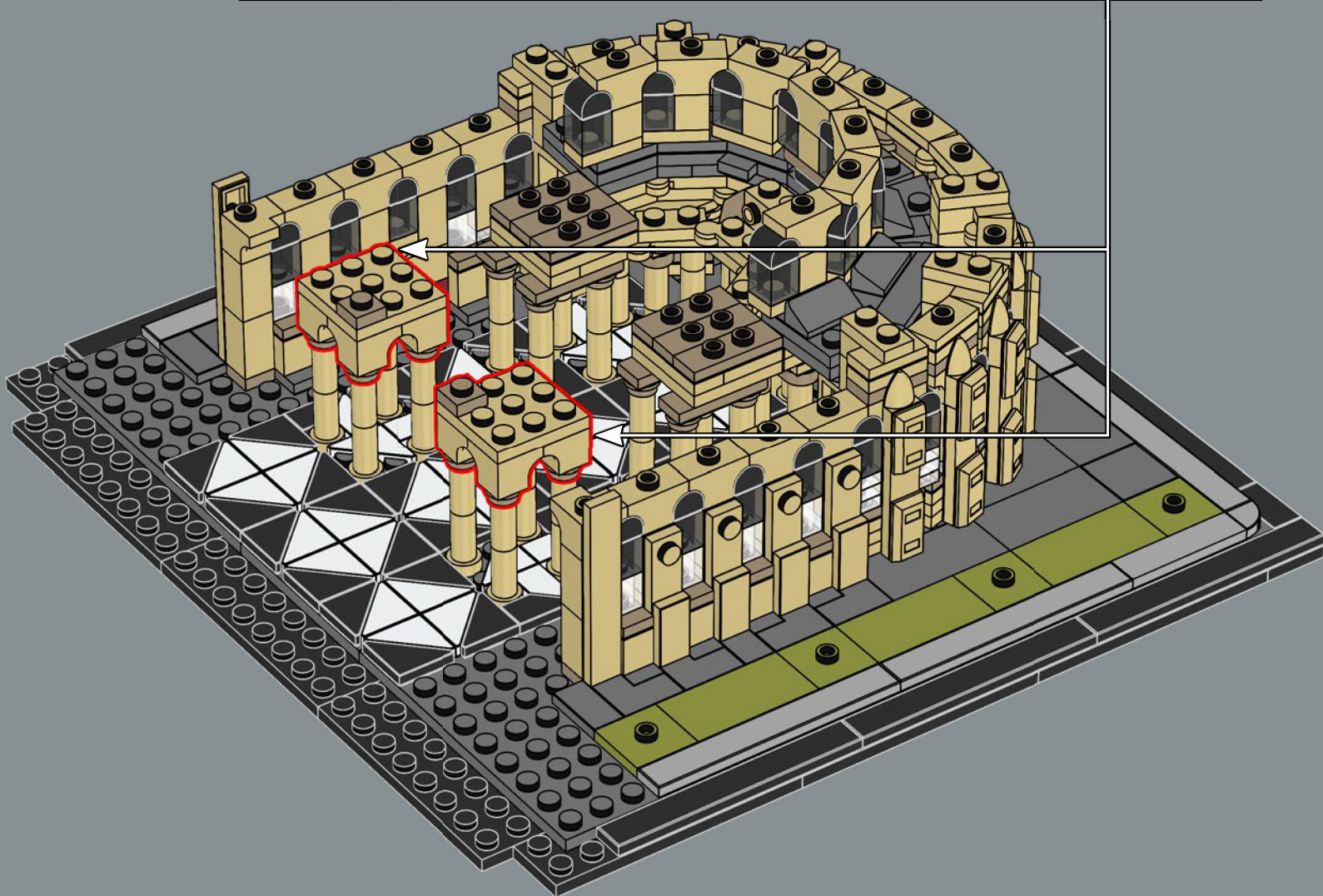
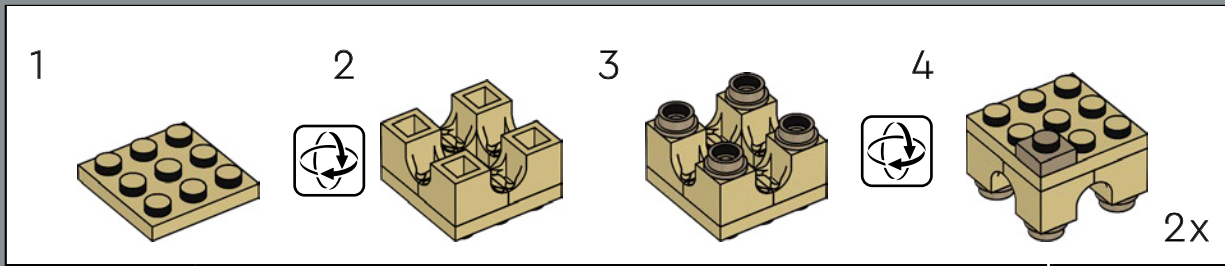

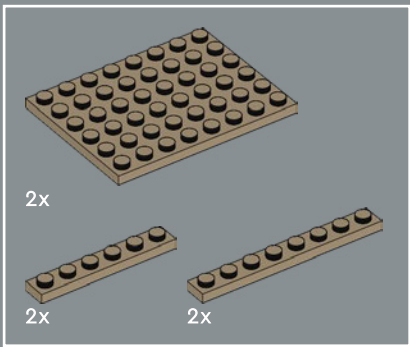

82

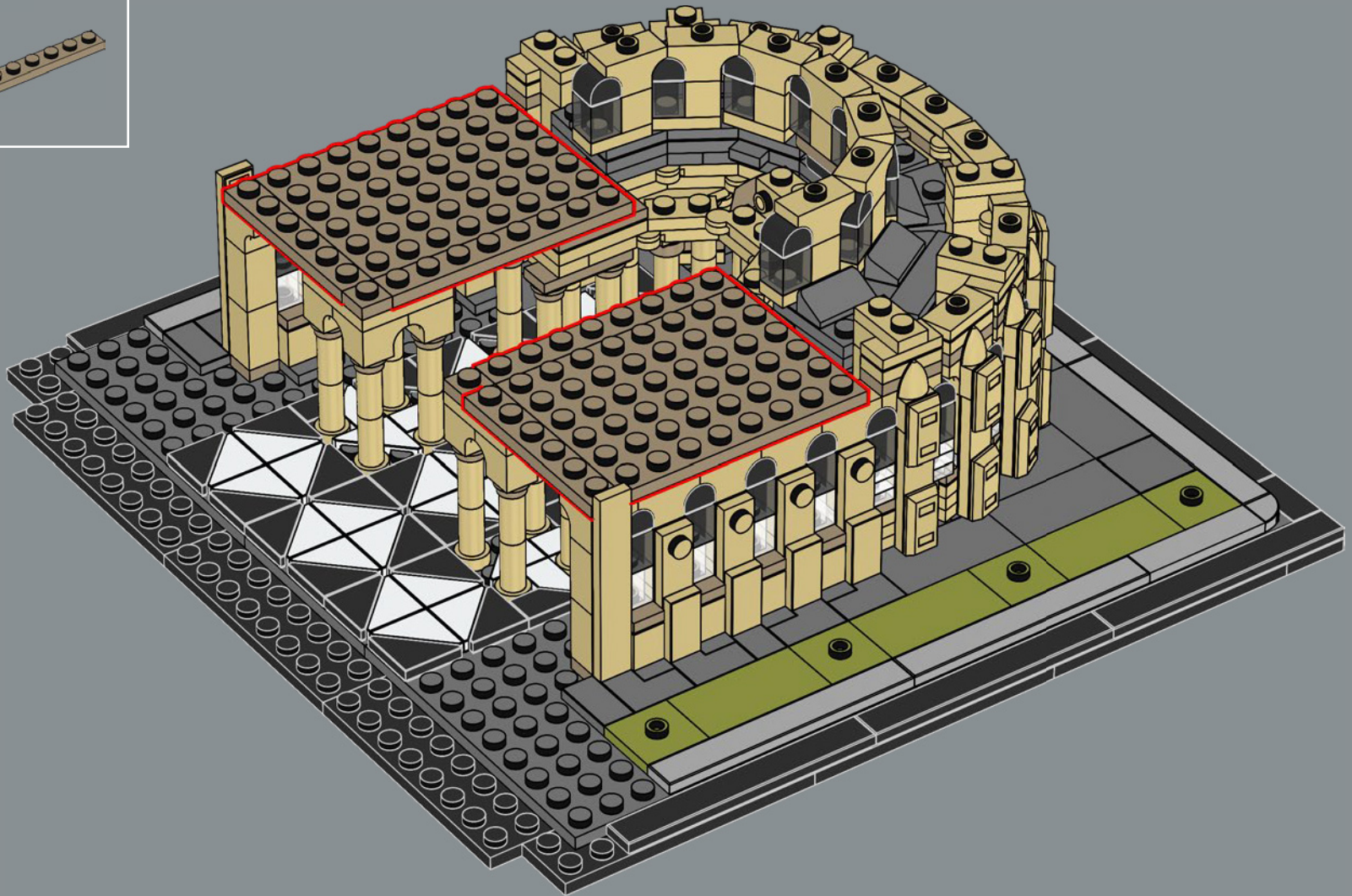



83

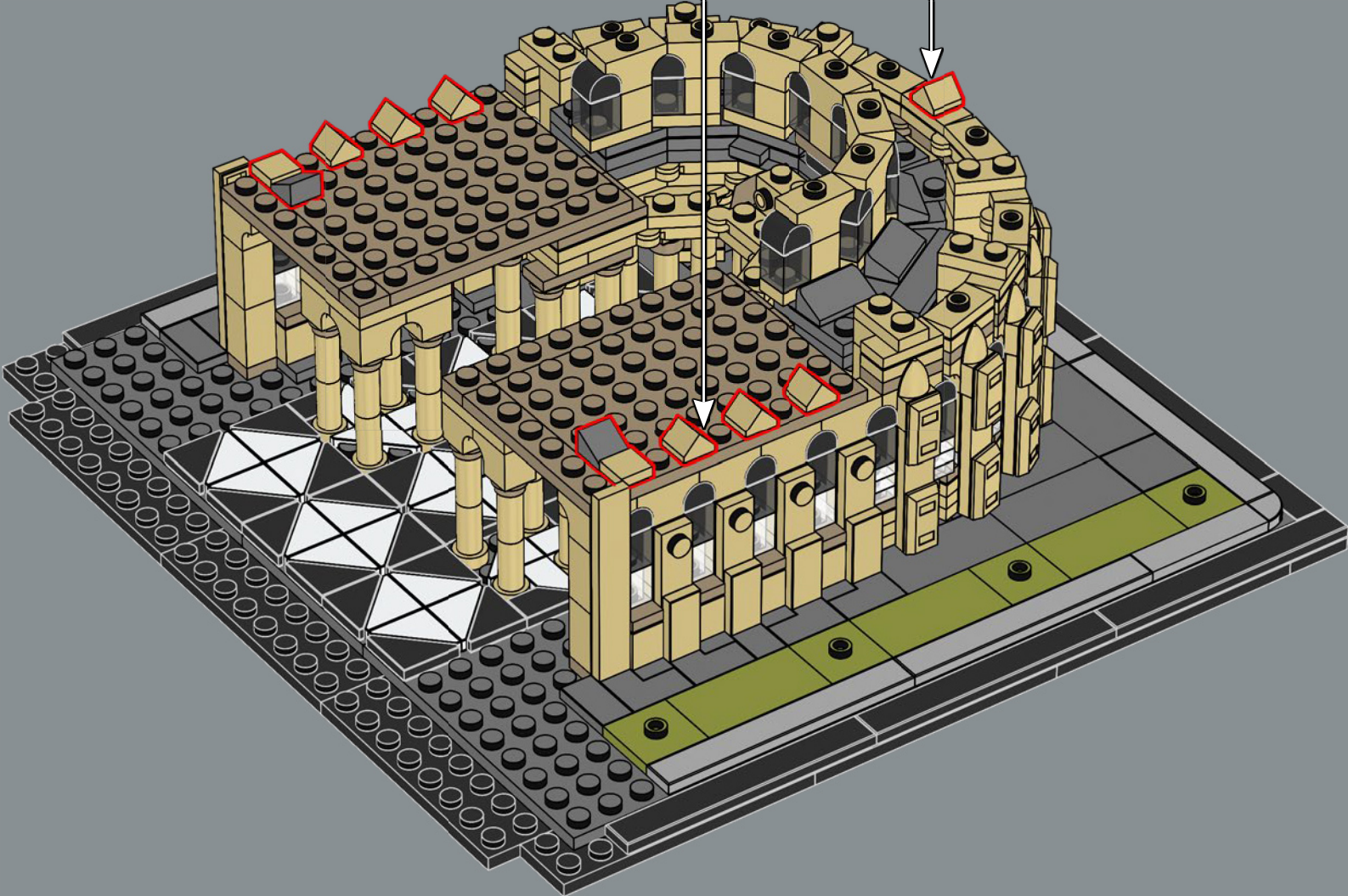

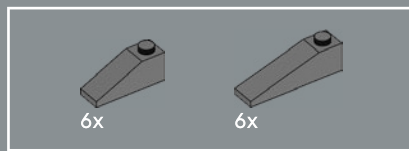

84

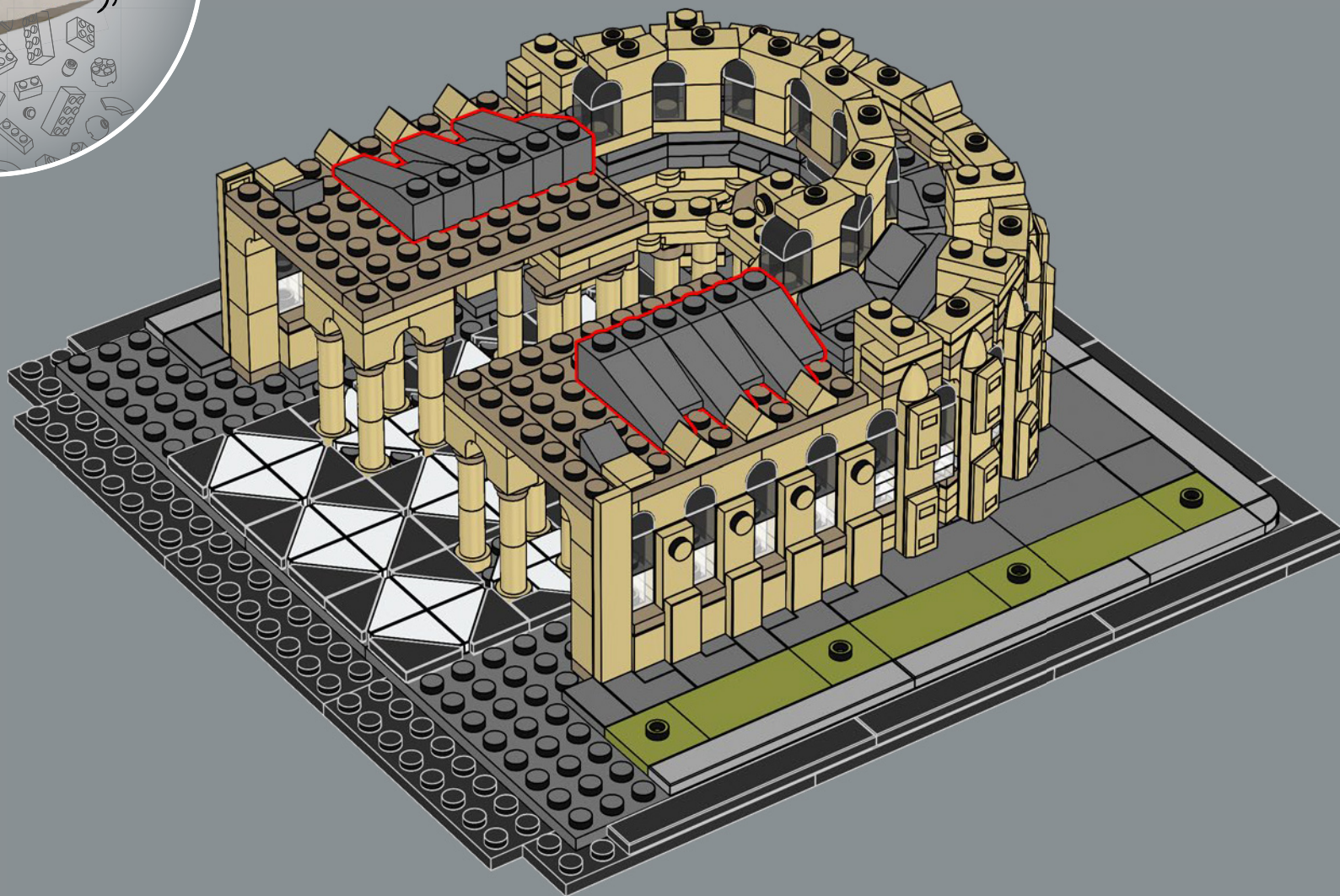

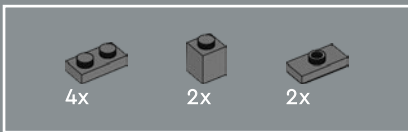

85

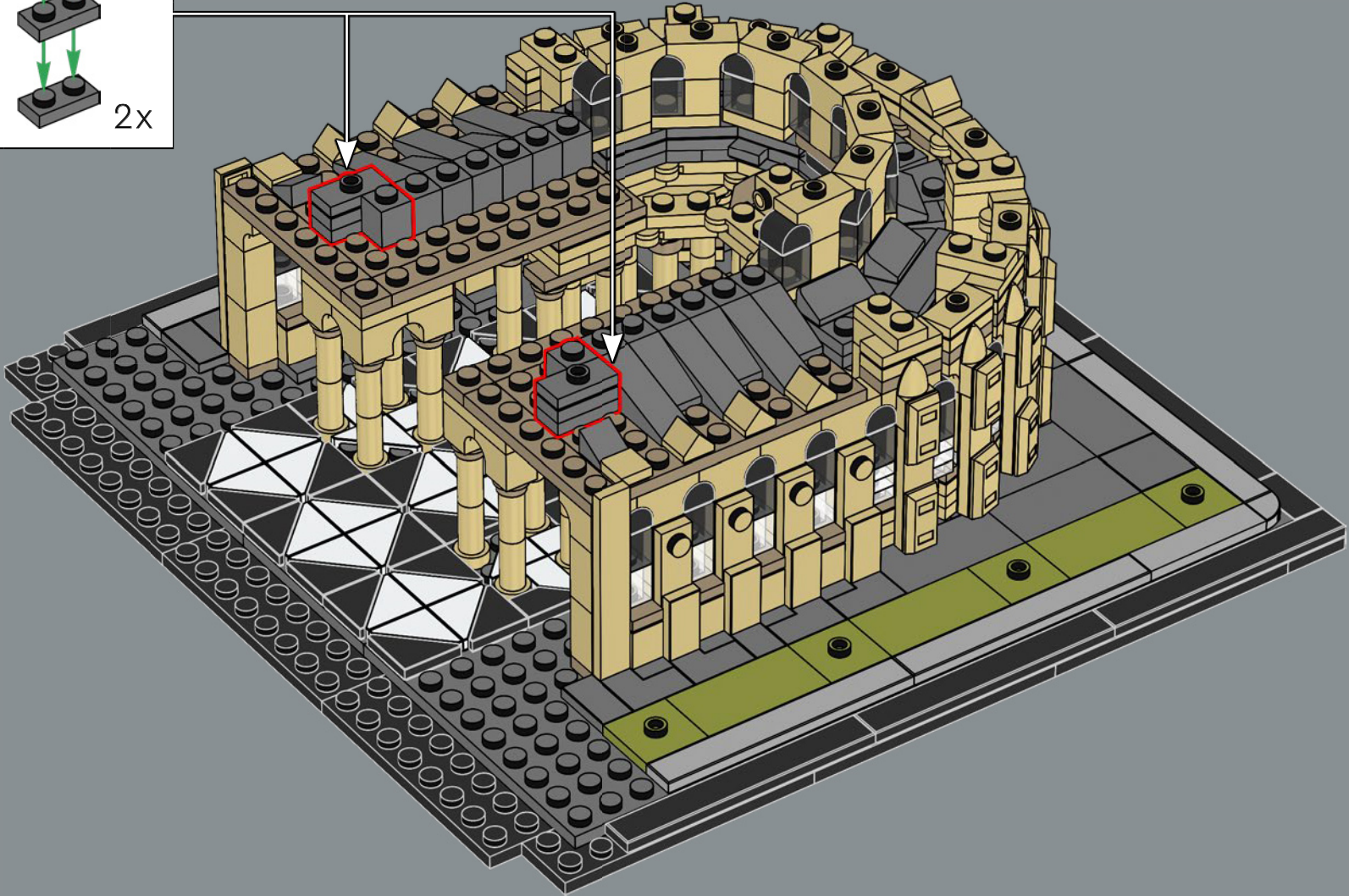
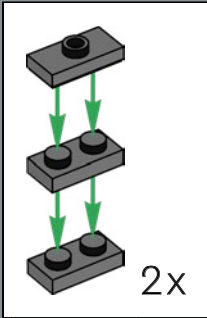



12x

86

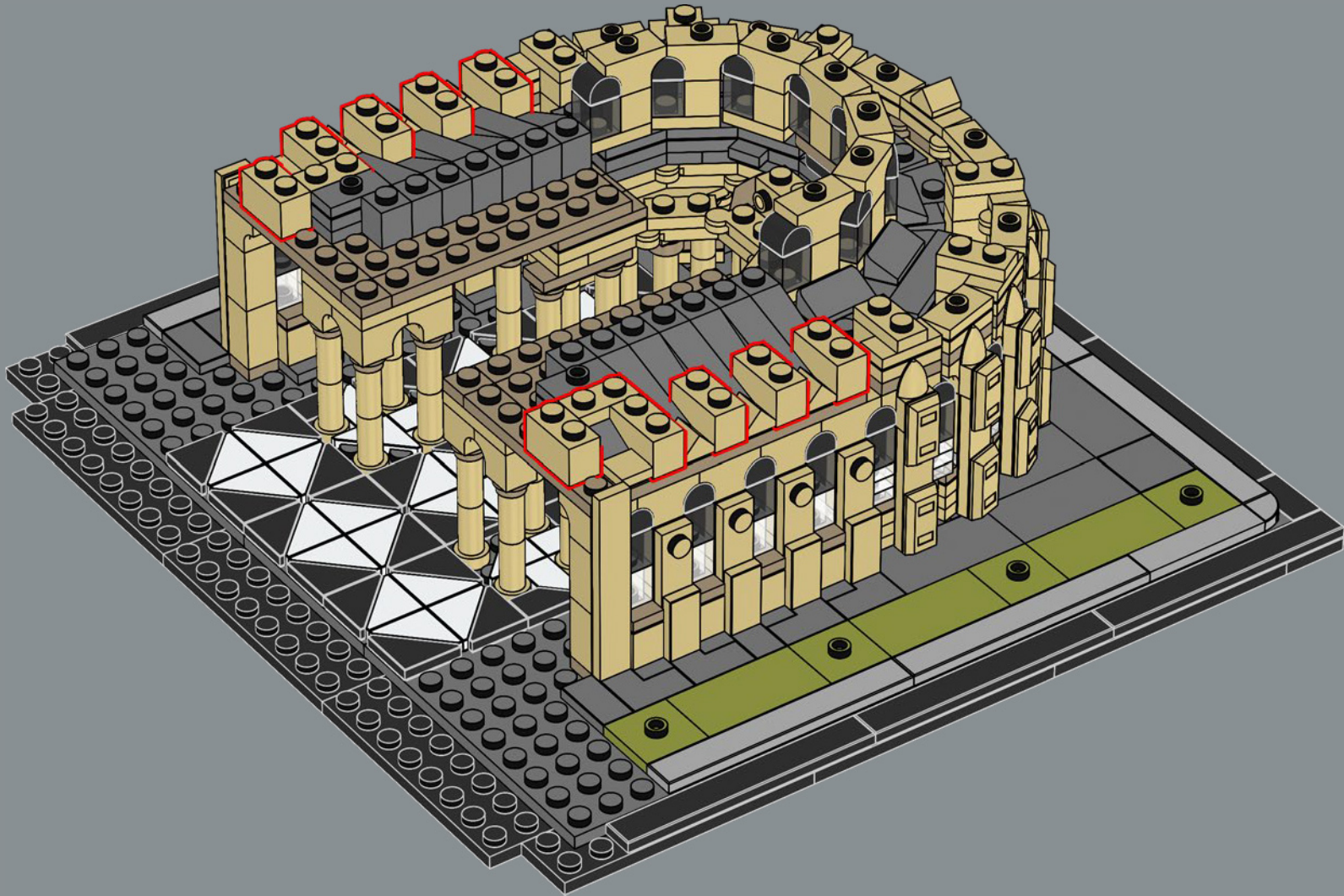



-   
8x
-   
8x
-   
2x
-   
14x
-   
8x

87

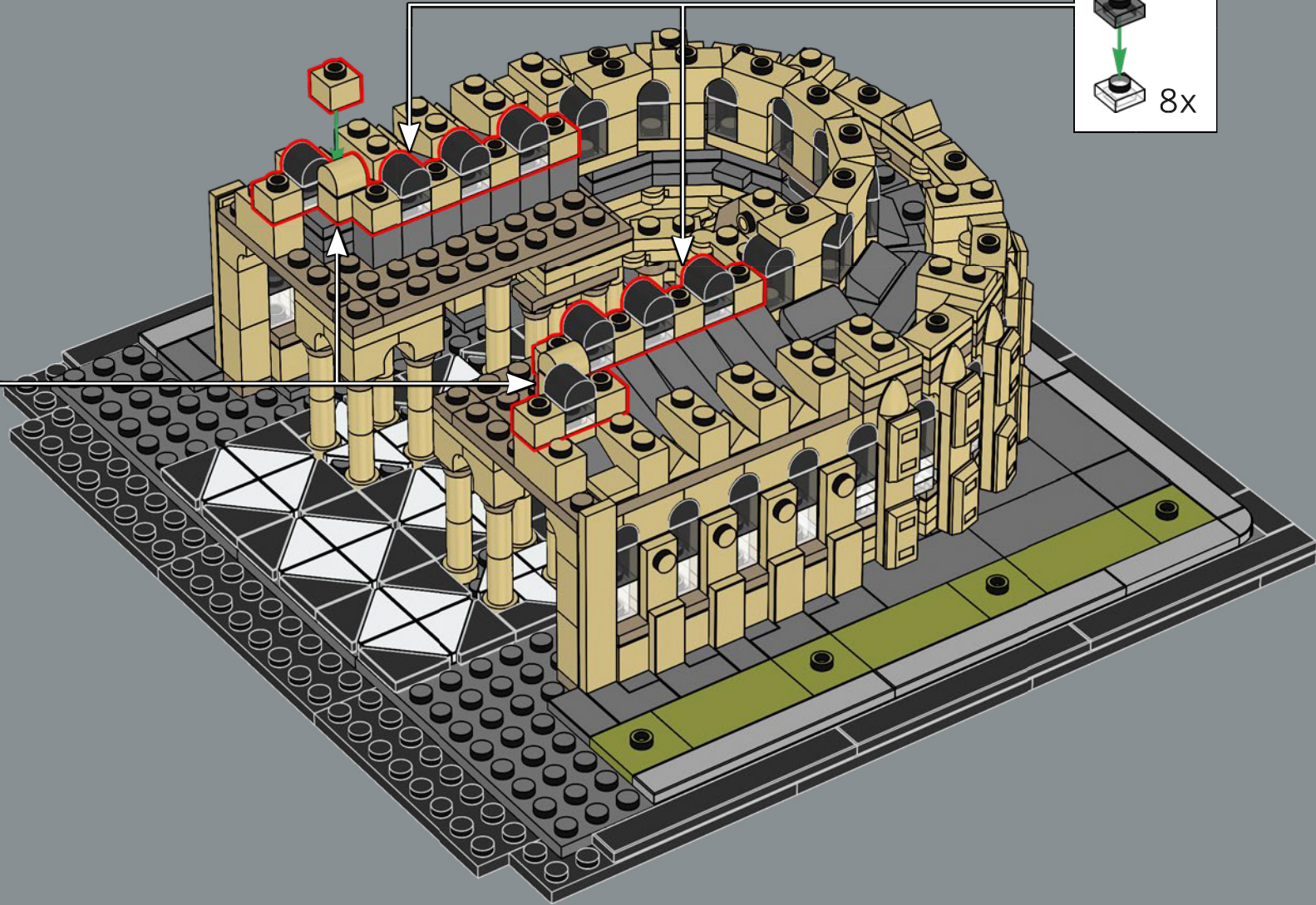
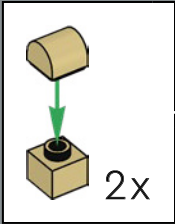
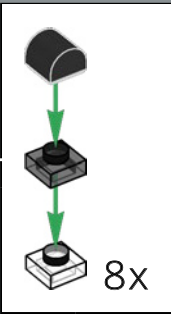

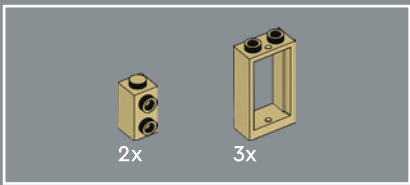

88

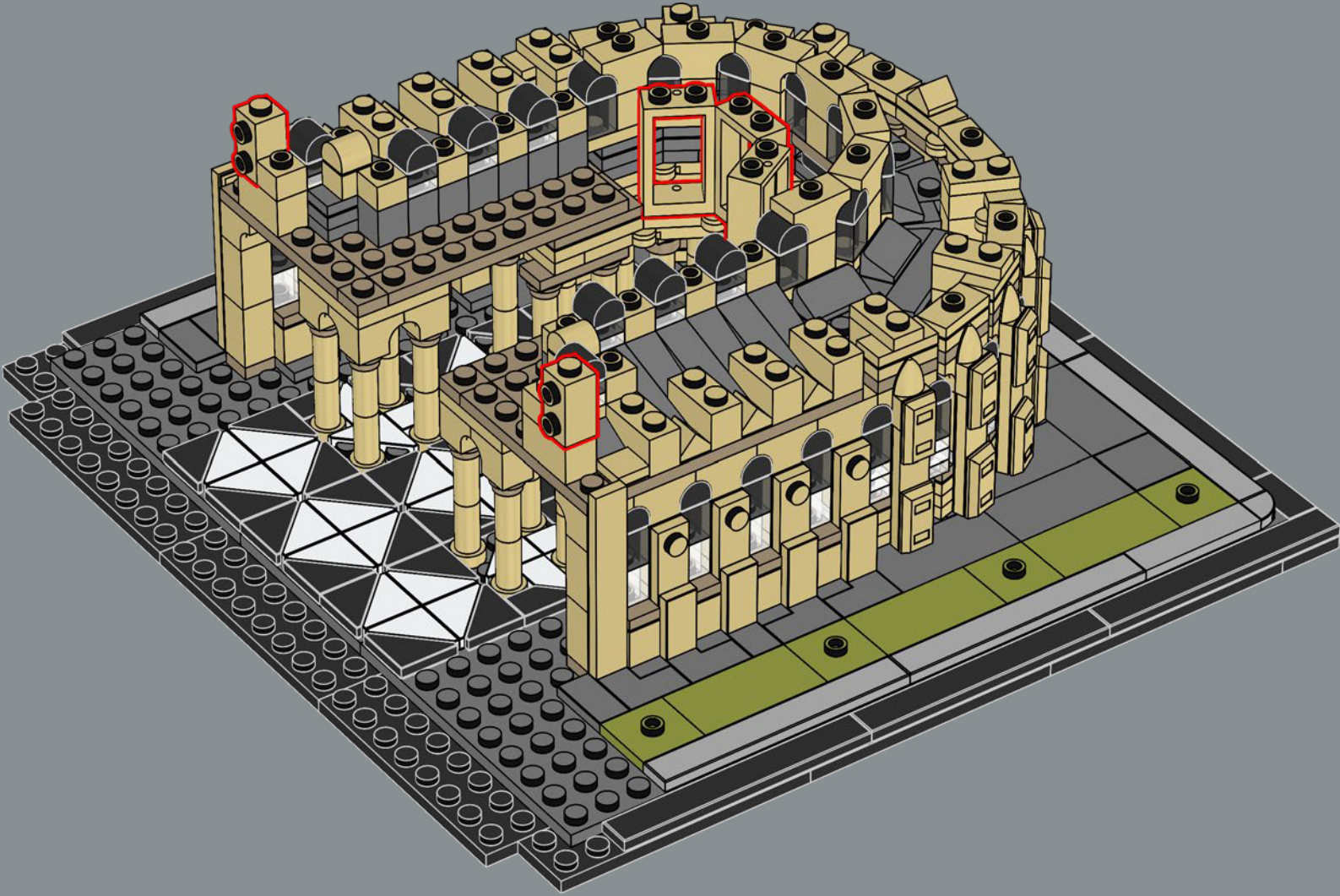

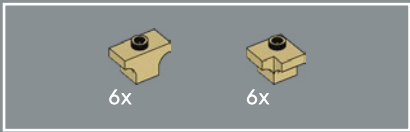

89

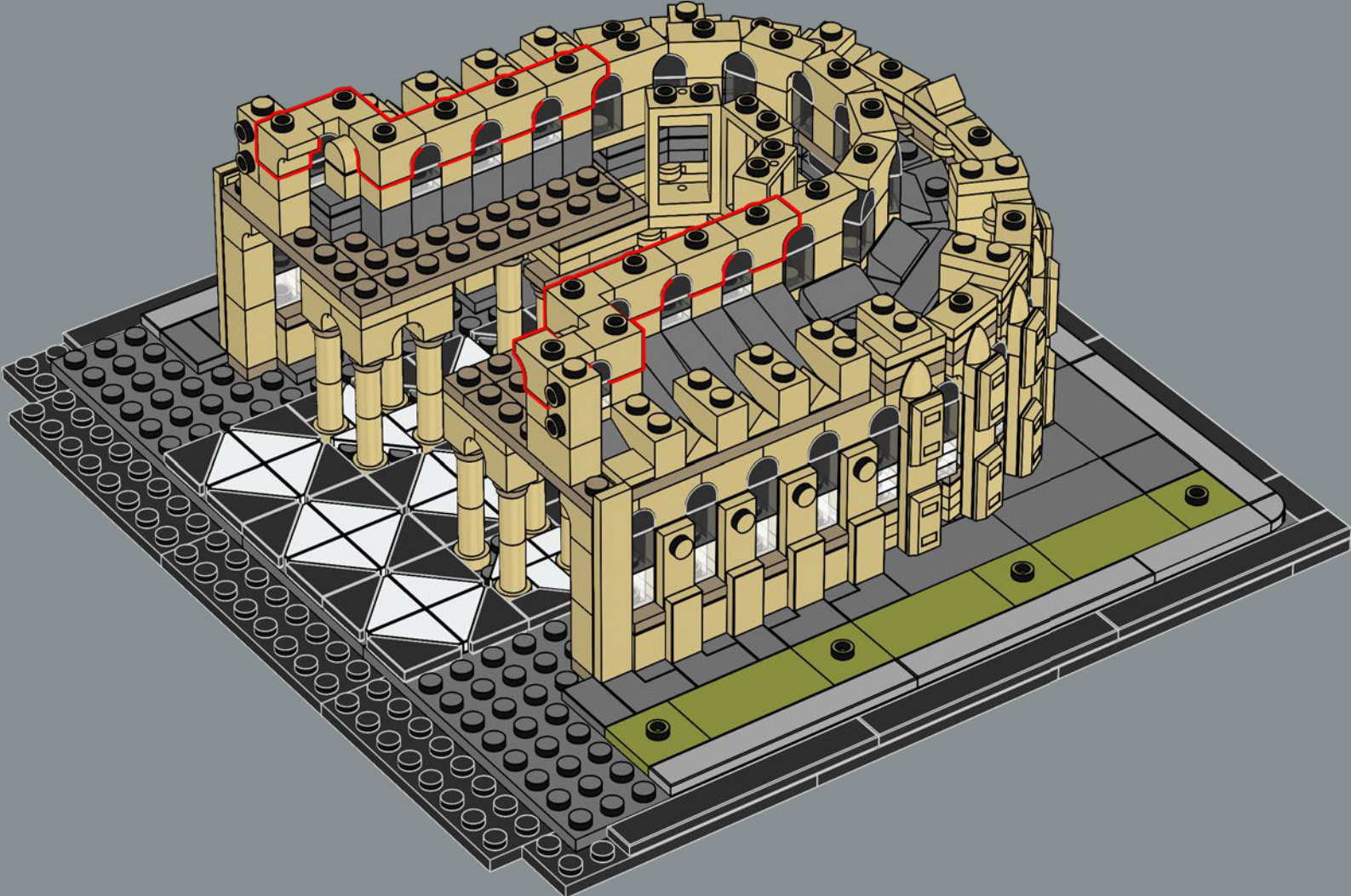

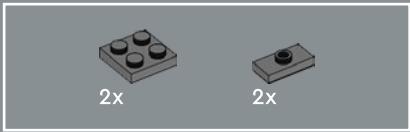

90

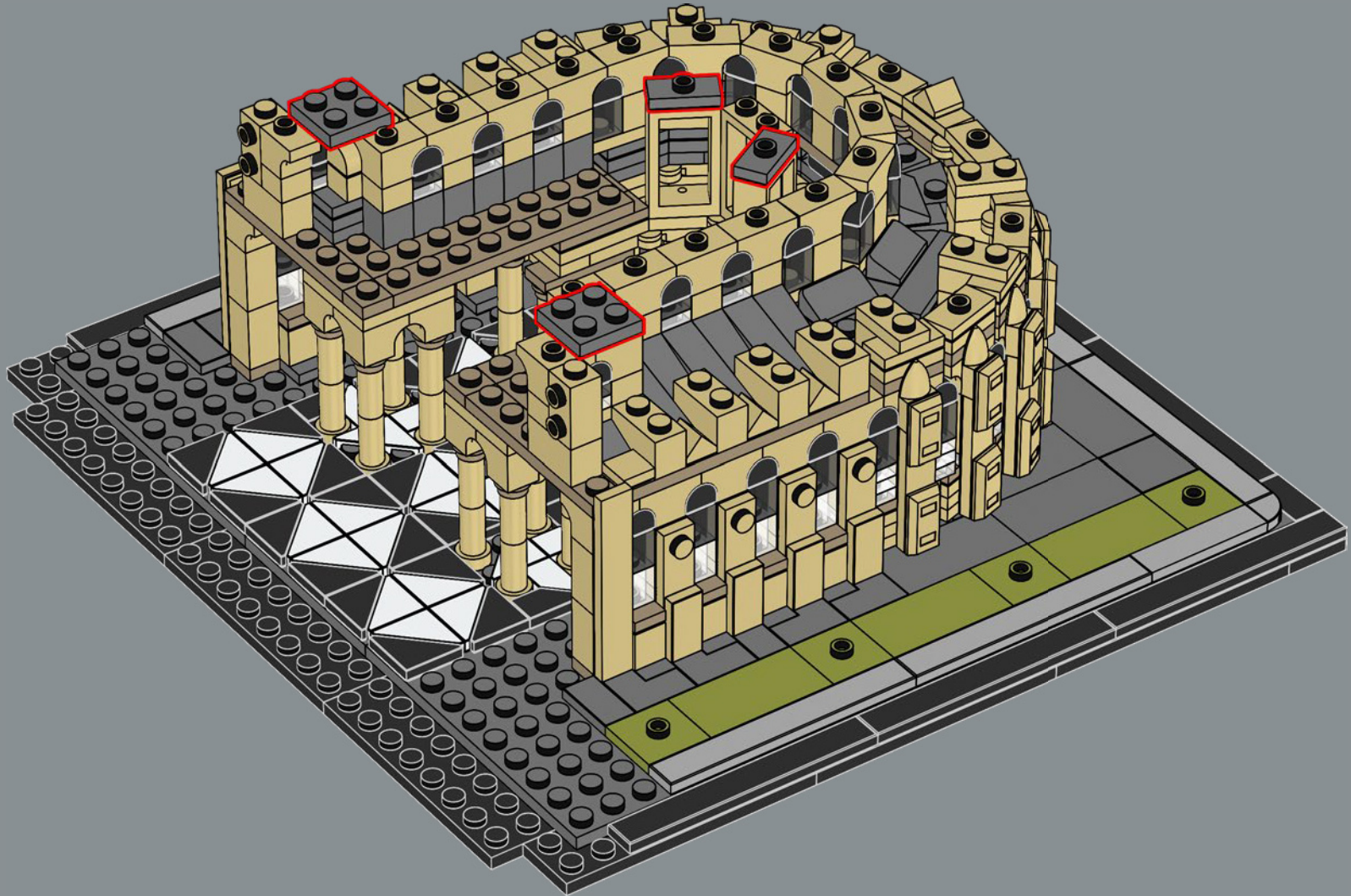



91

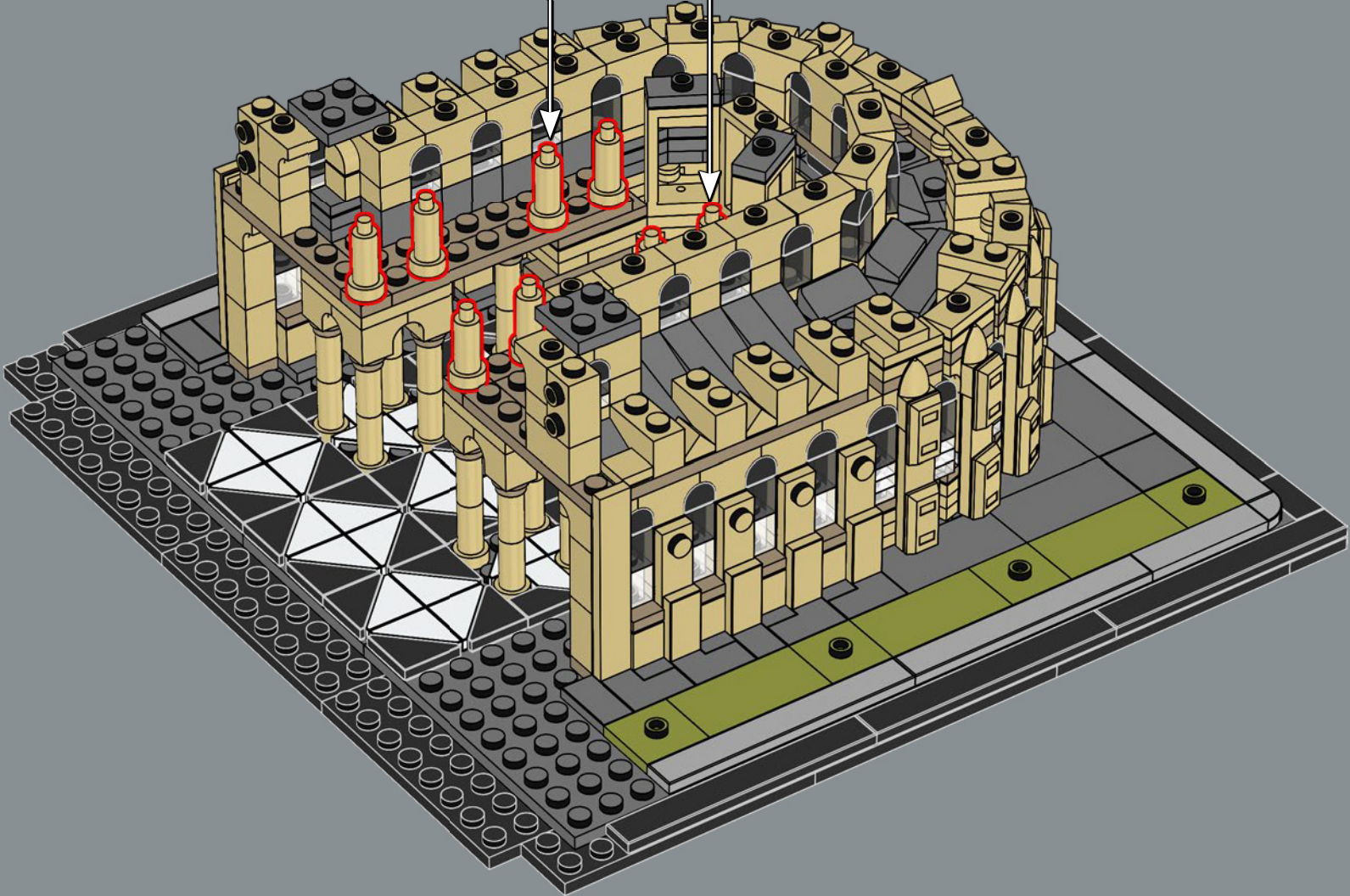
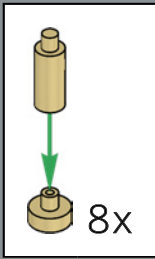

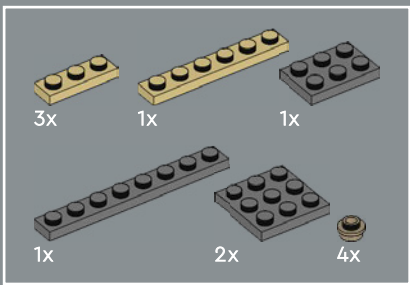

92

1

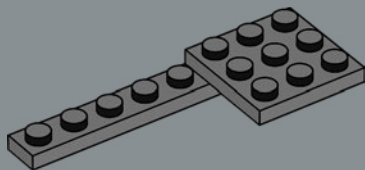

2

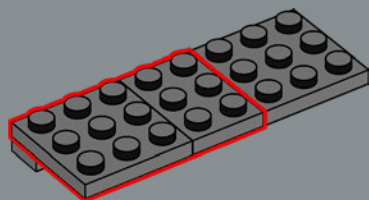

3

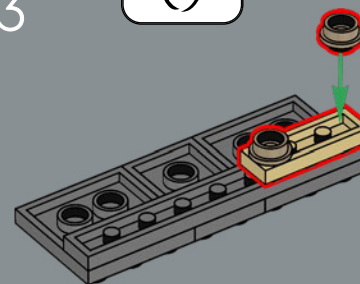

1

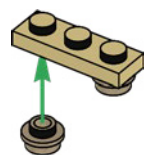

2

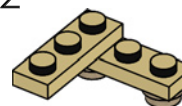

3

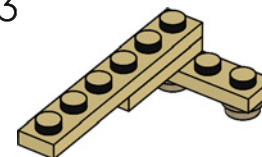

4

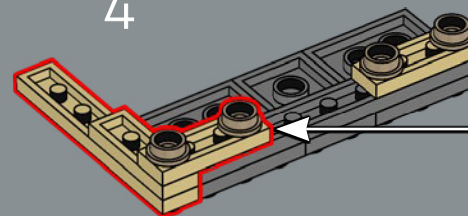

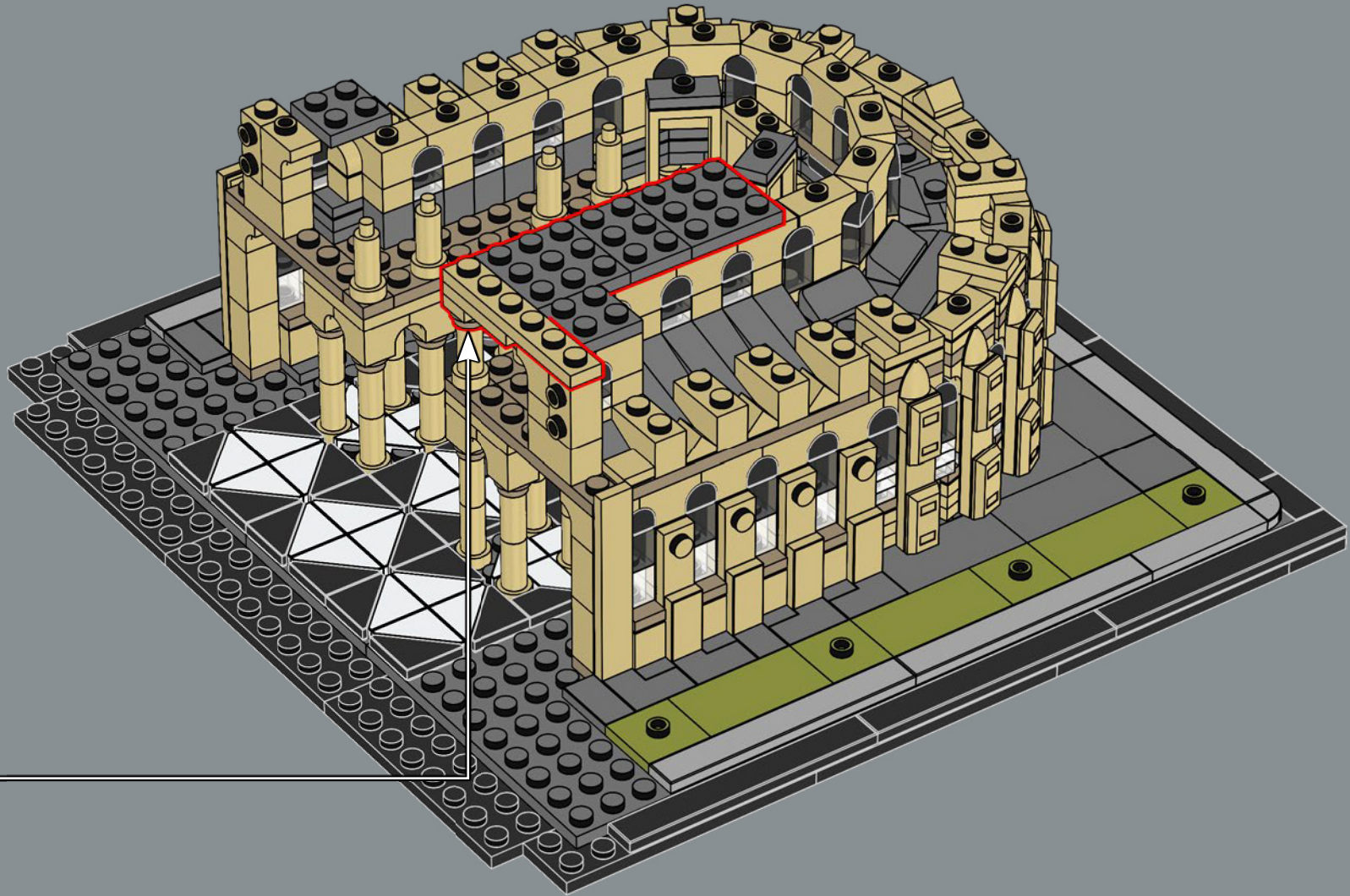

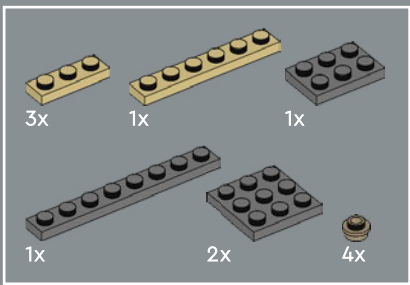

93

1

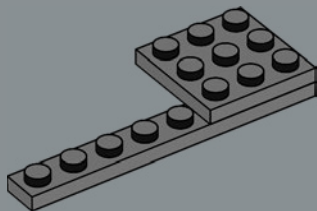

2

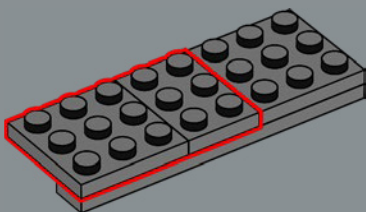

3

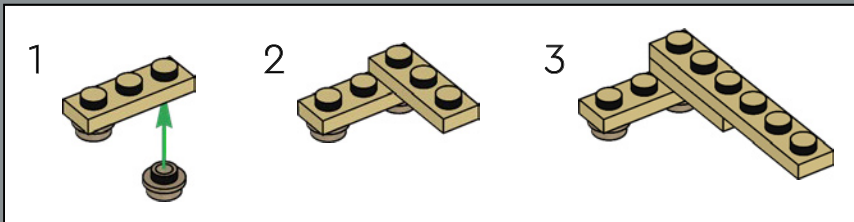
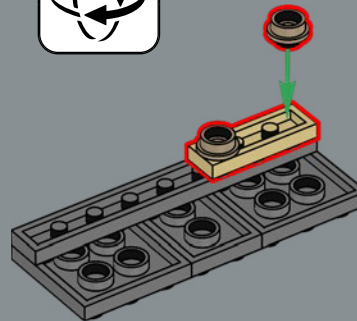

4

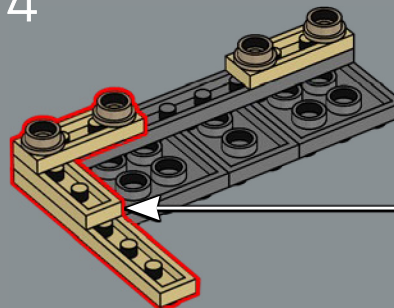



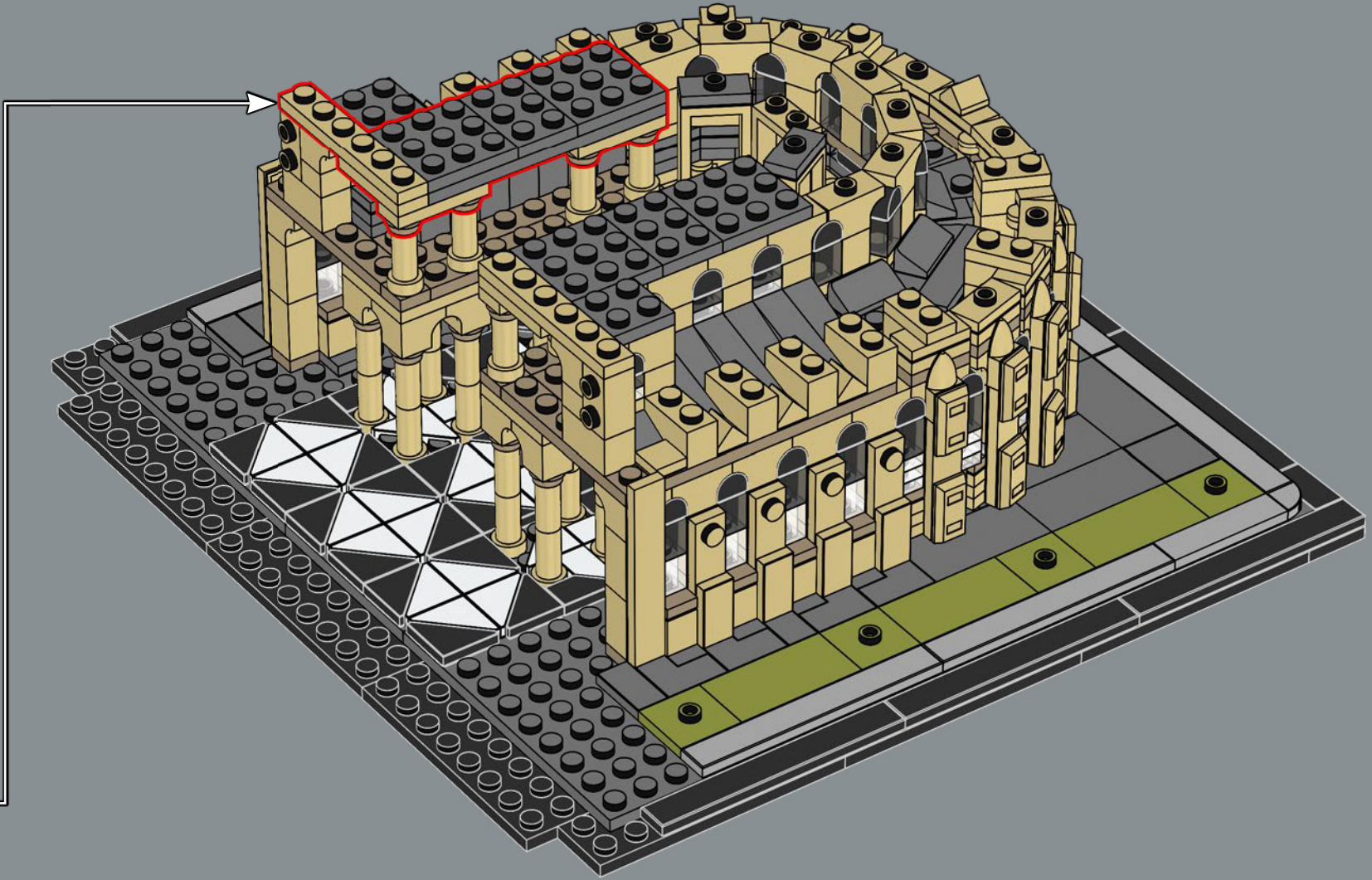



6x

94

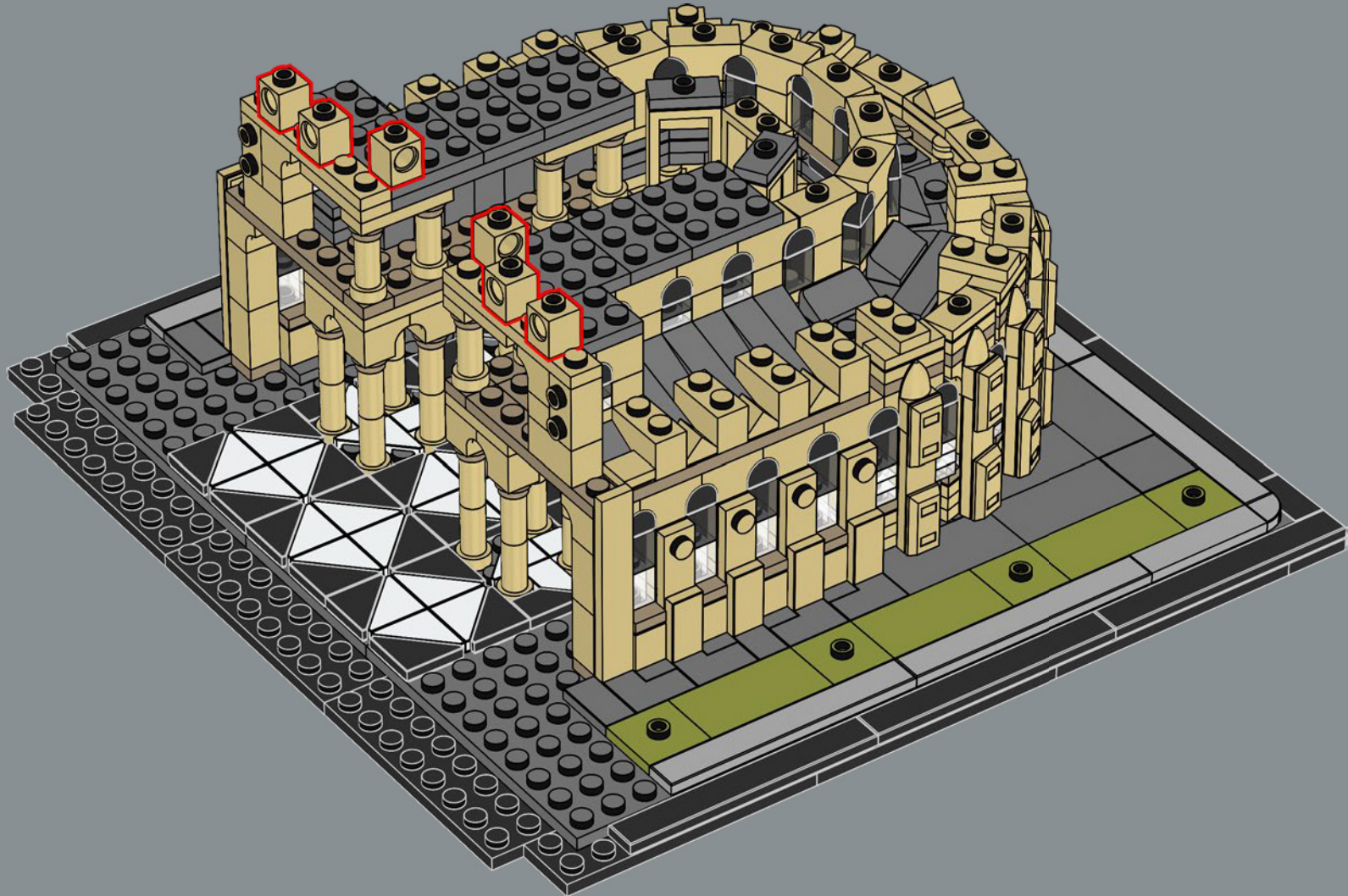



95

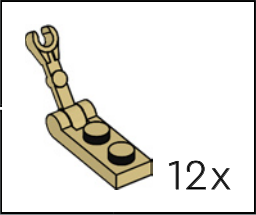

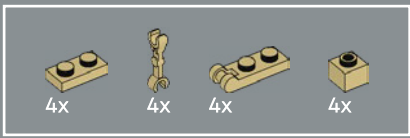

96

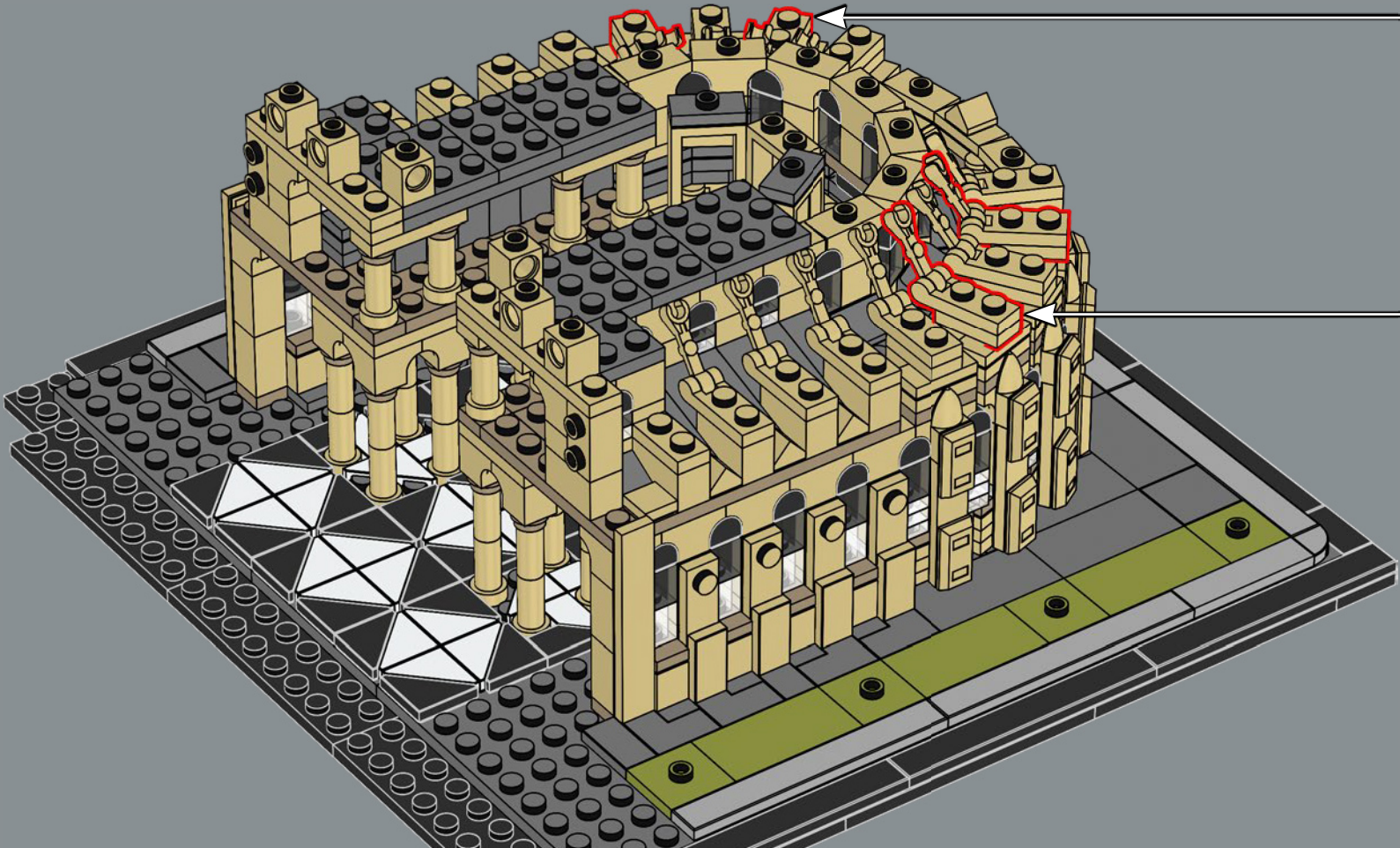
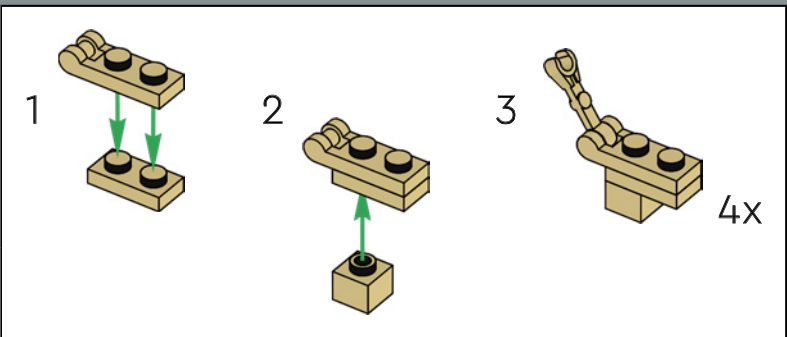

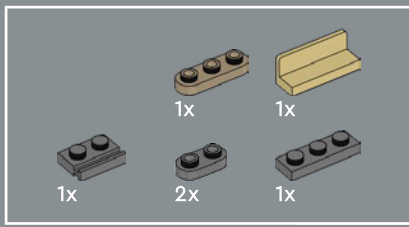

97

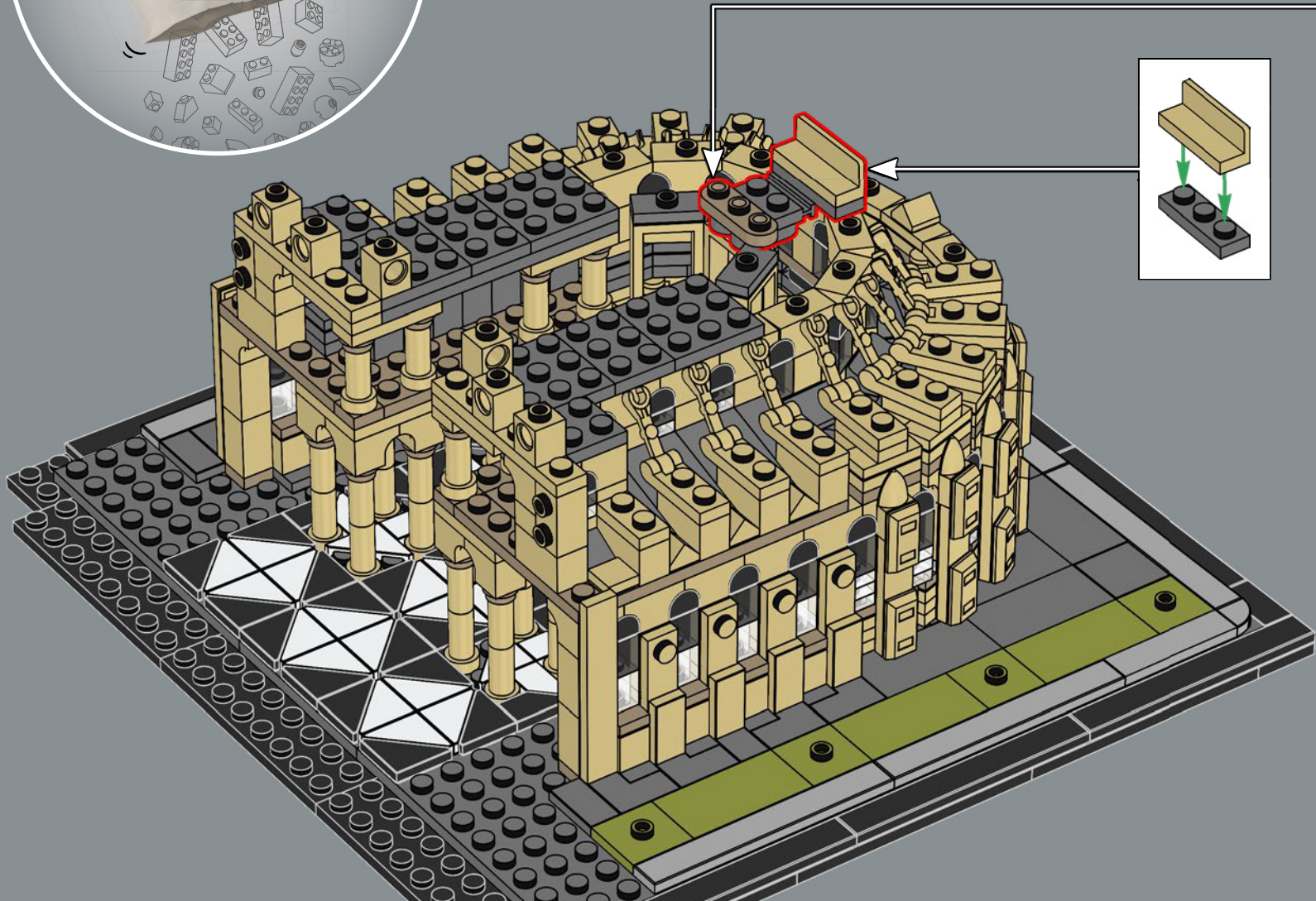
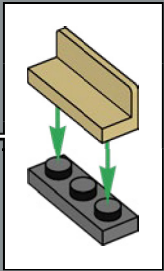
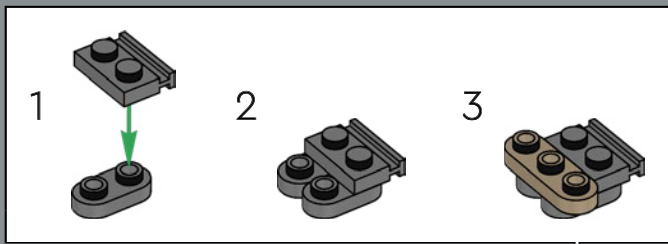



98

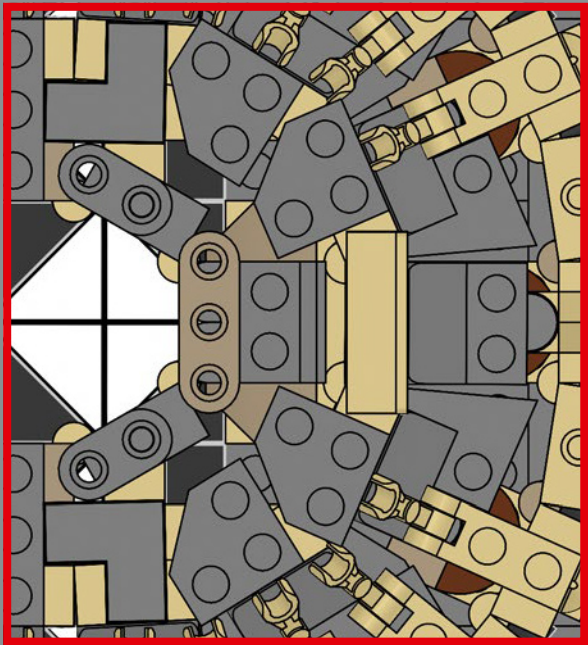
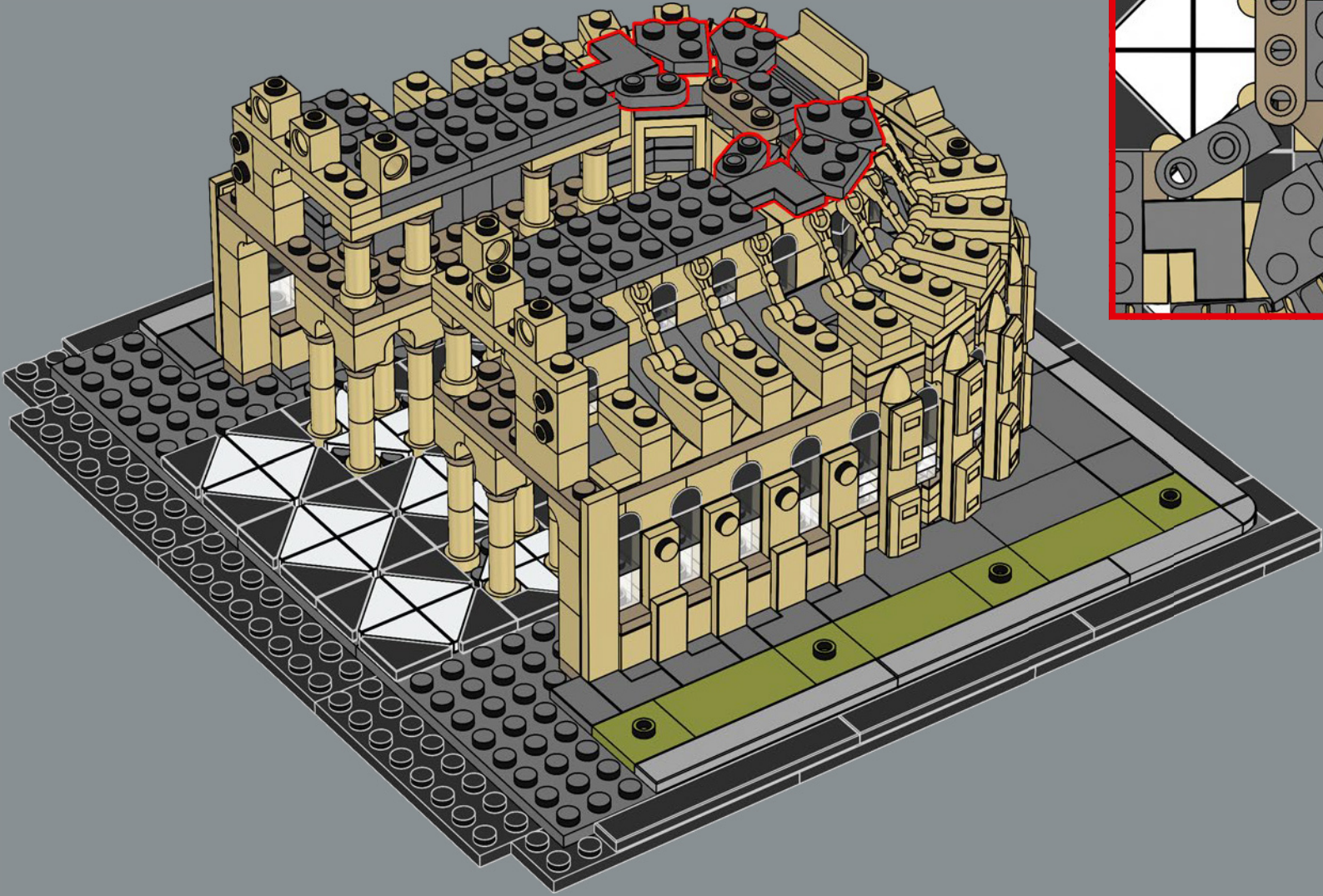

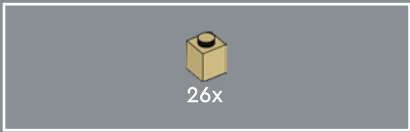

99

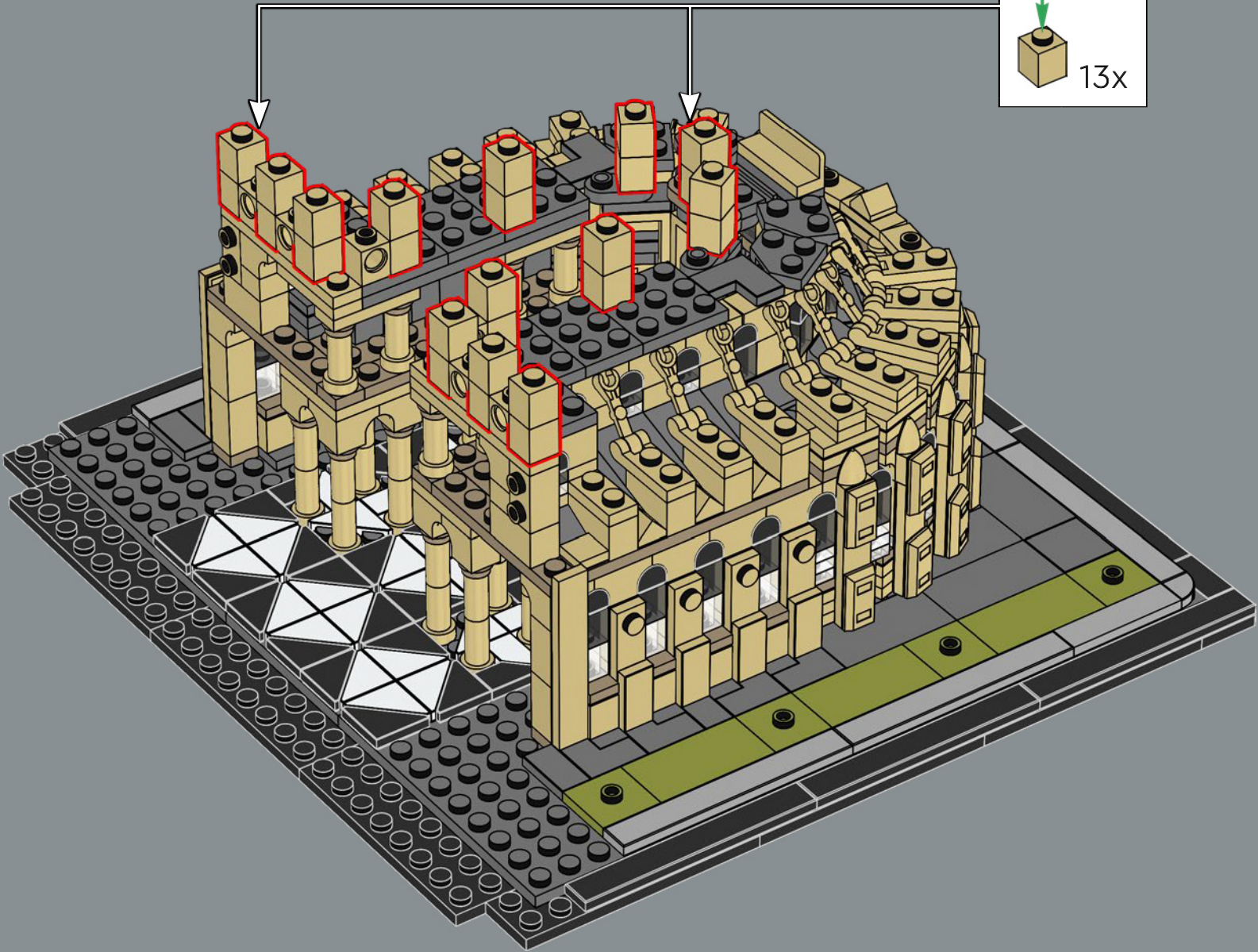
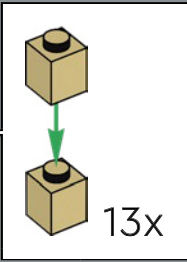

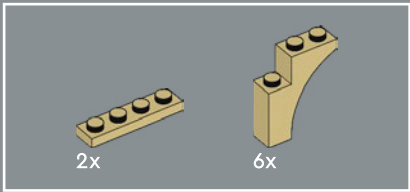

100

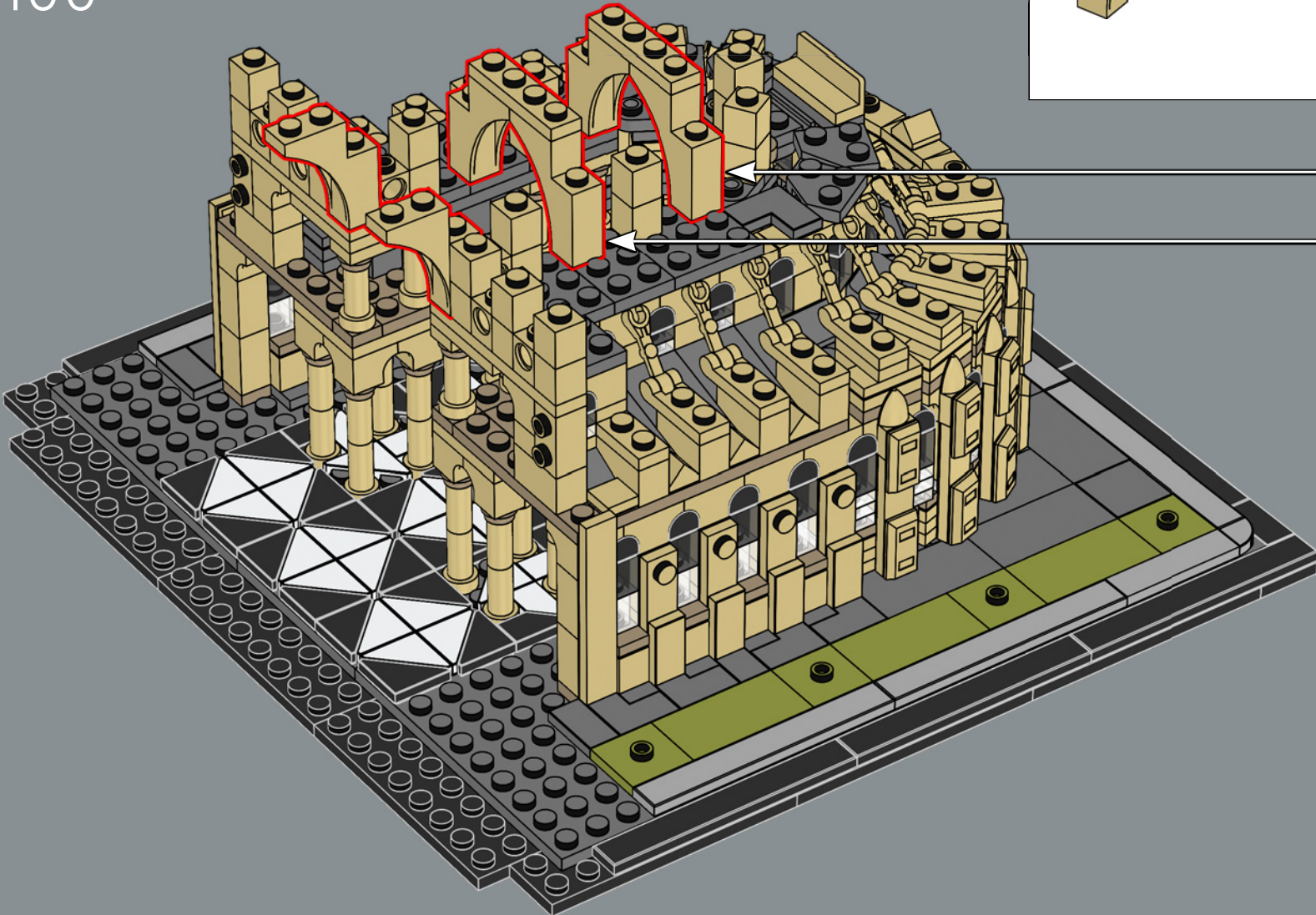
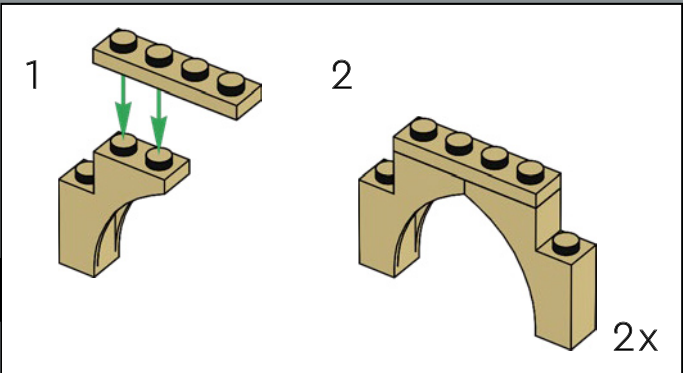



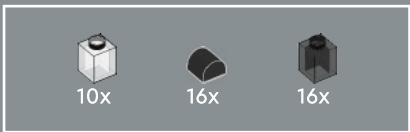

101

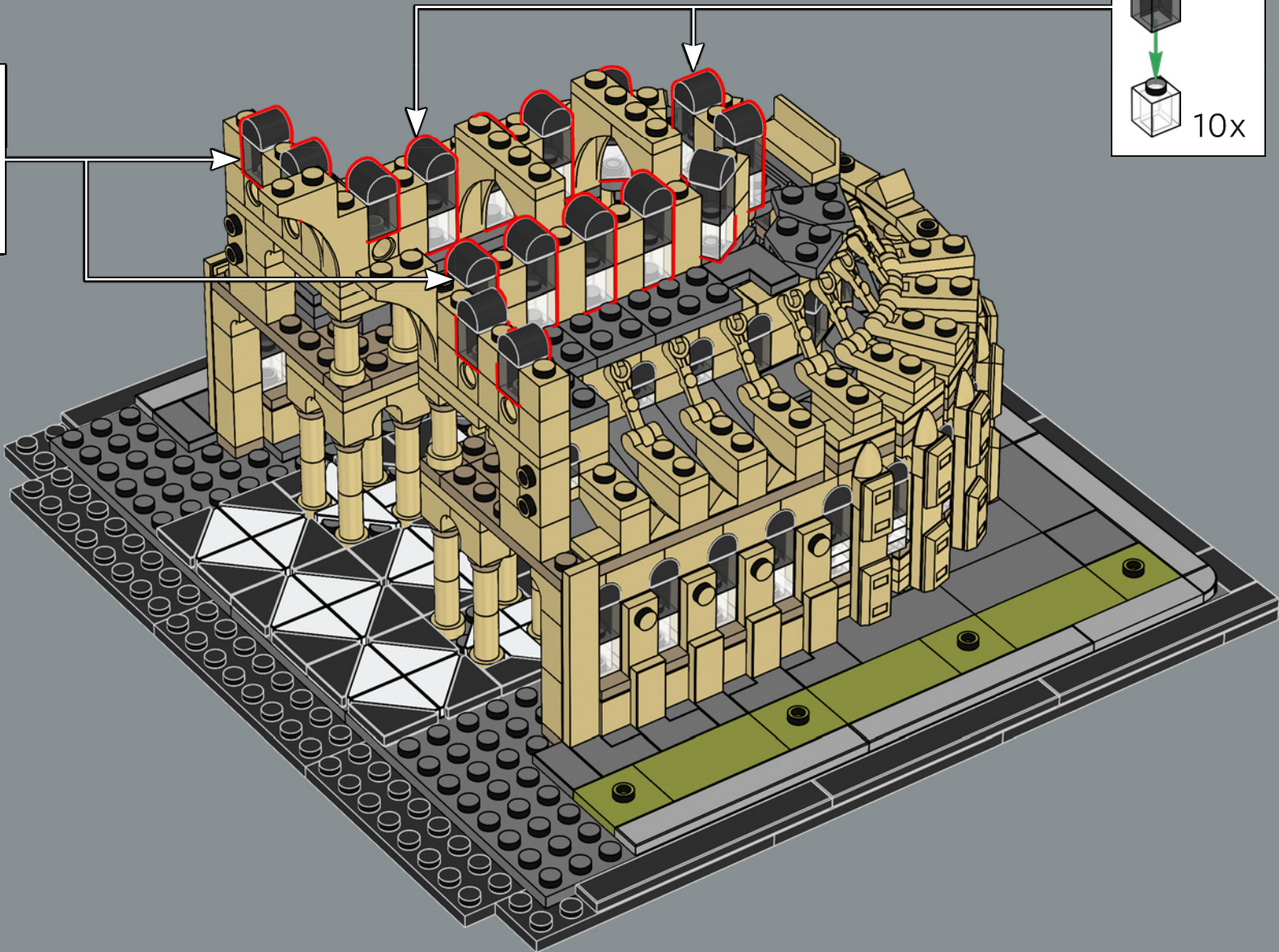
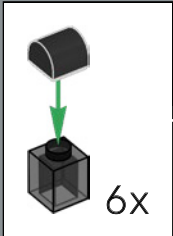

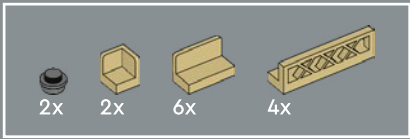

102

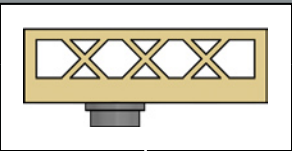
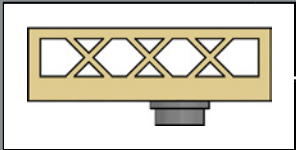
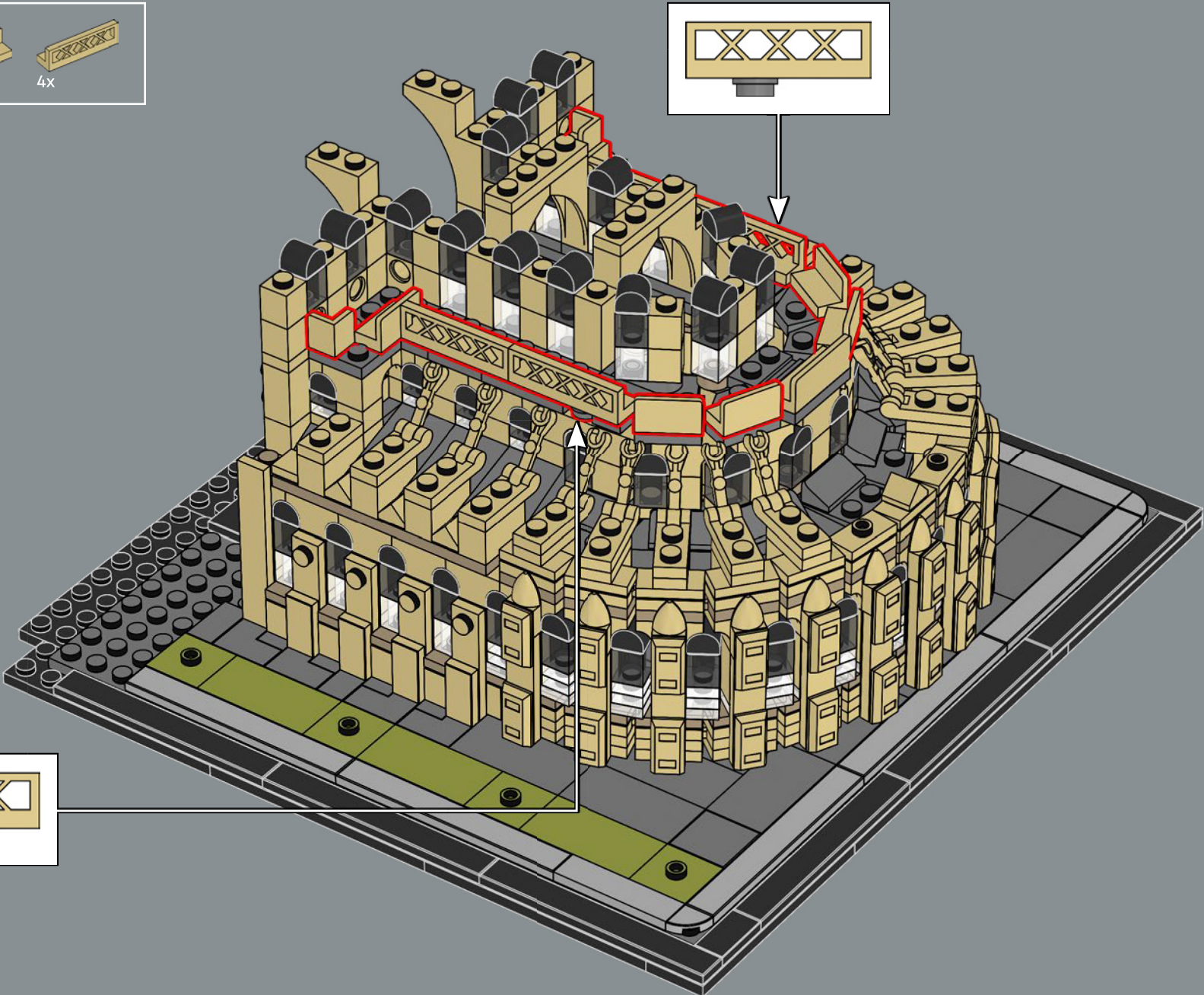

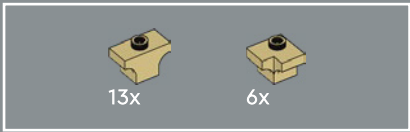

103

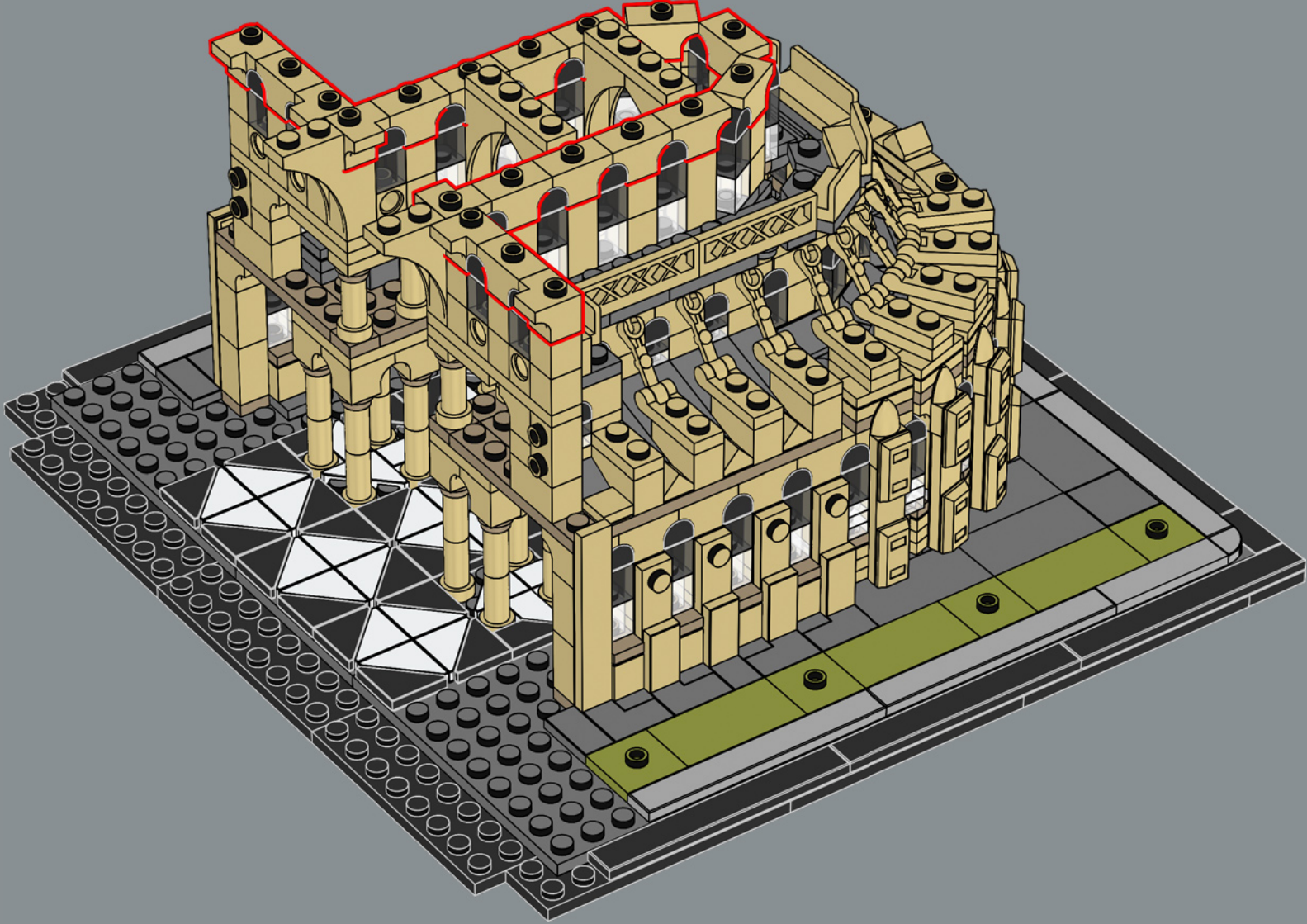

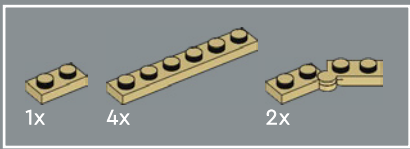

104

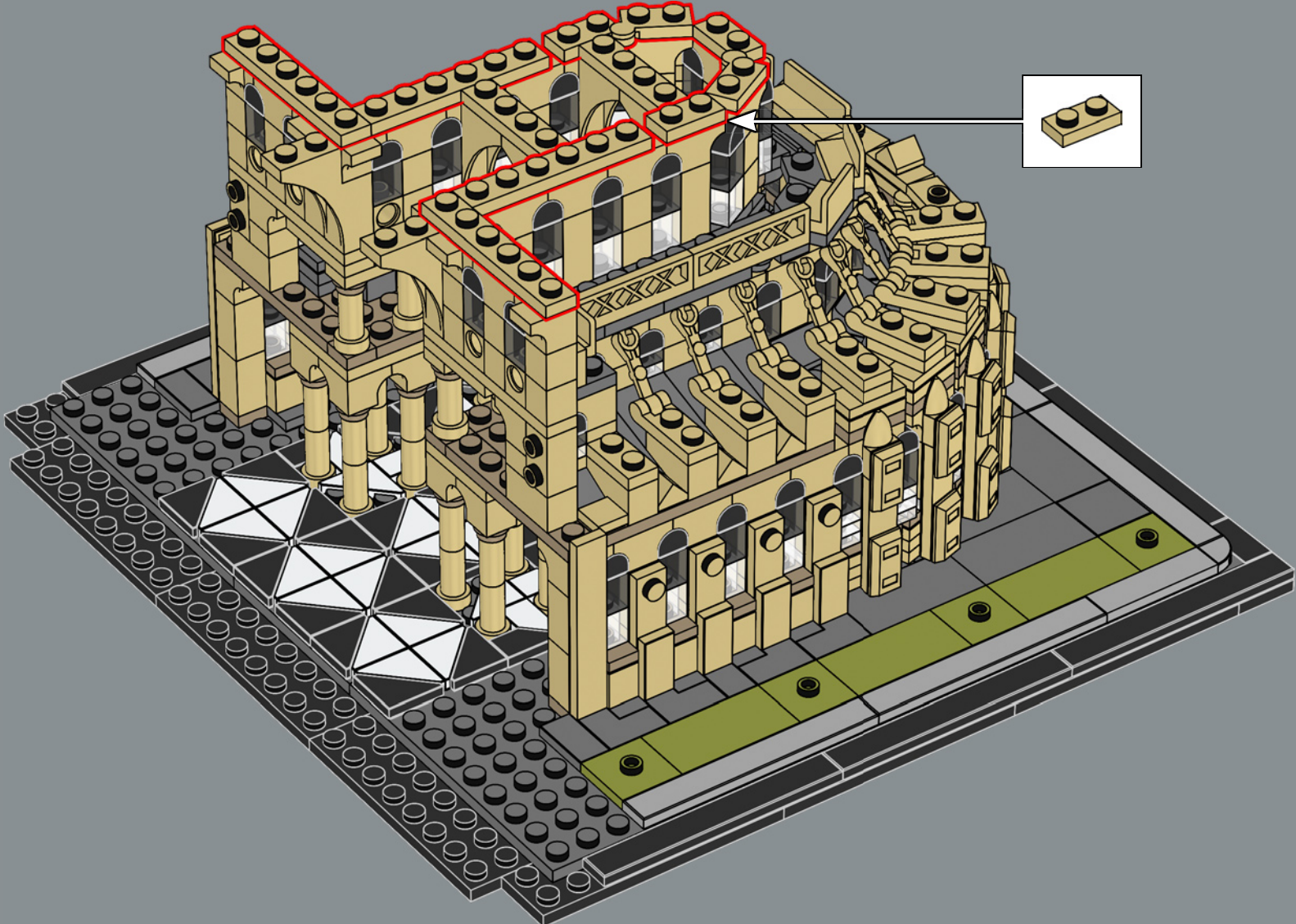

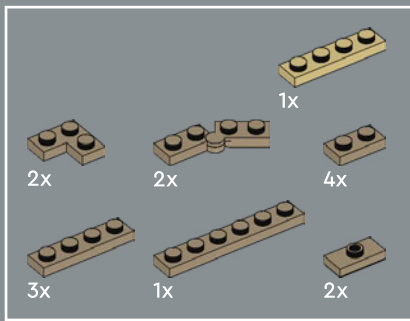

105

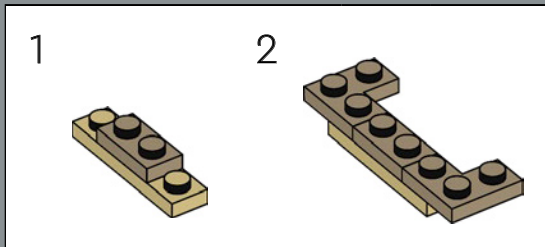
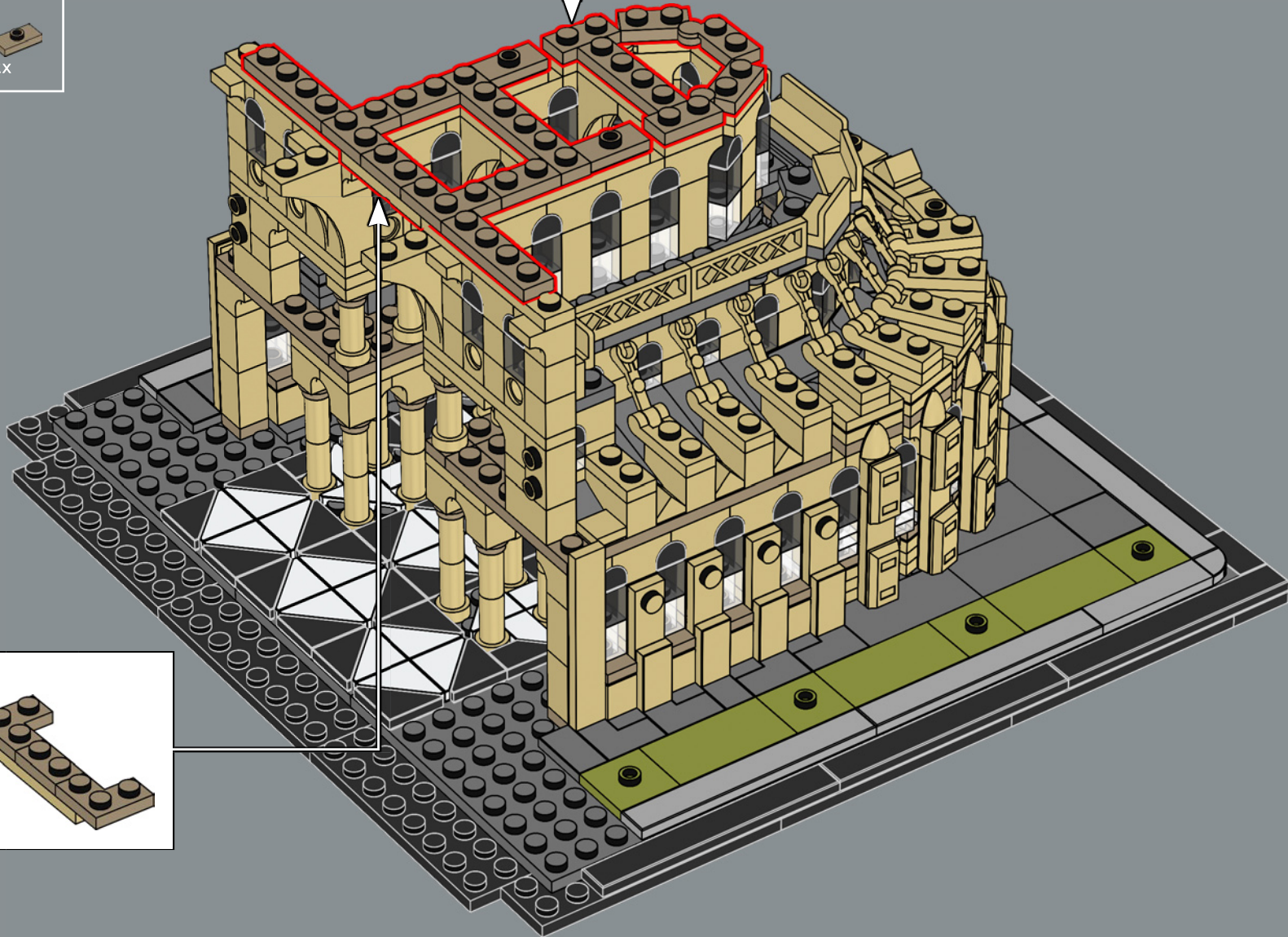
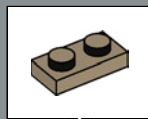

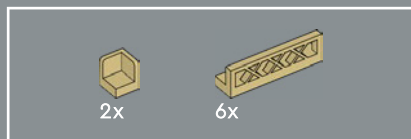

106

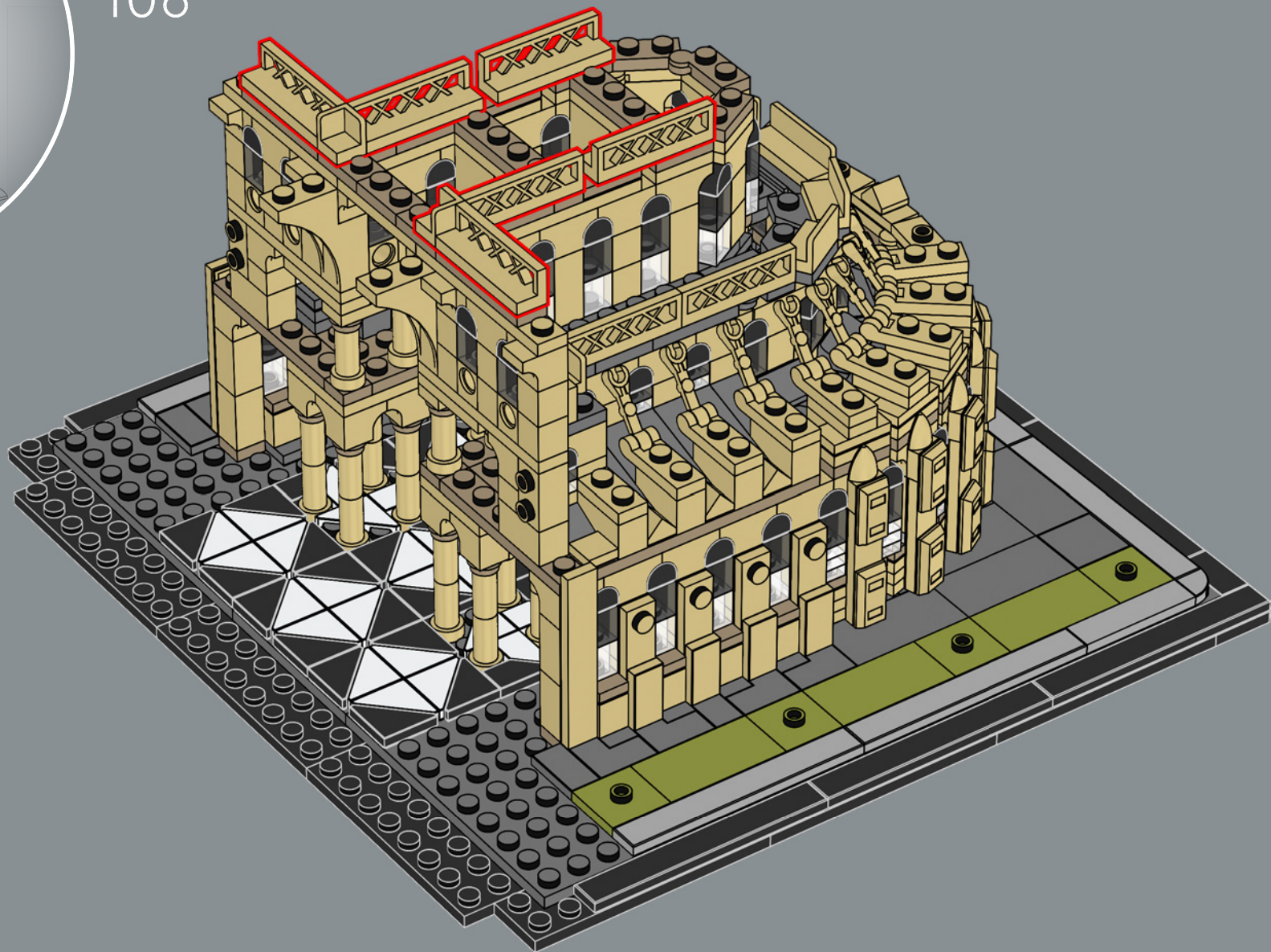

6x      10x

4x

6x

107

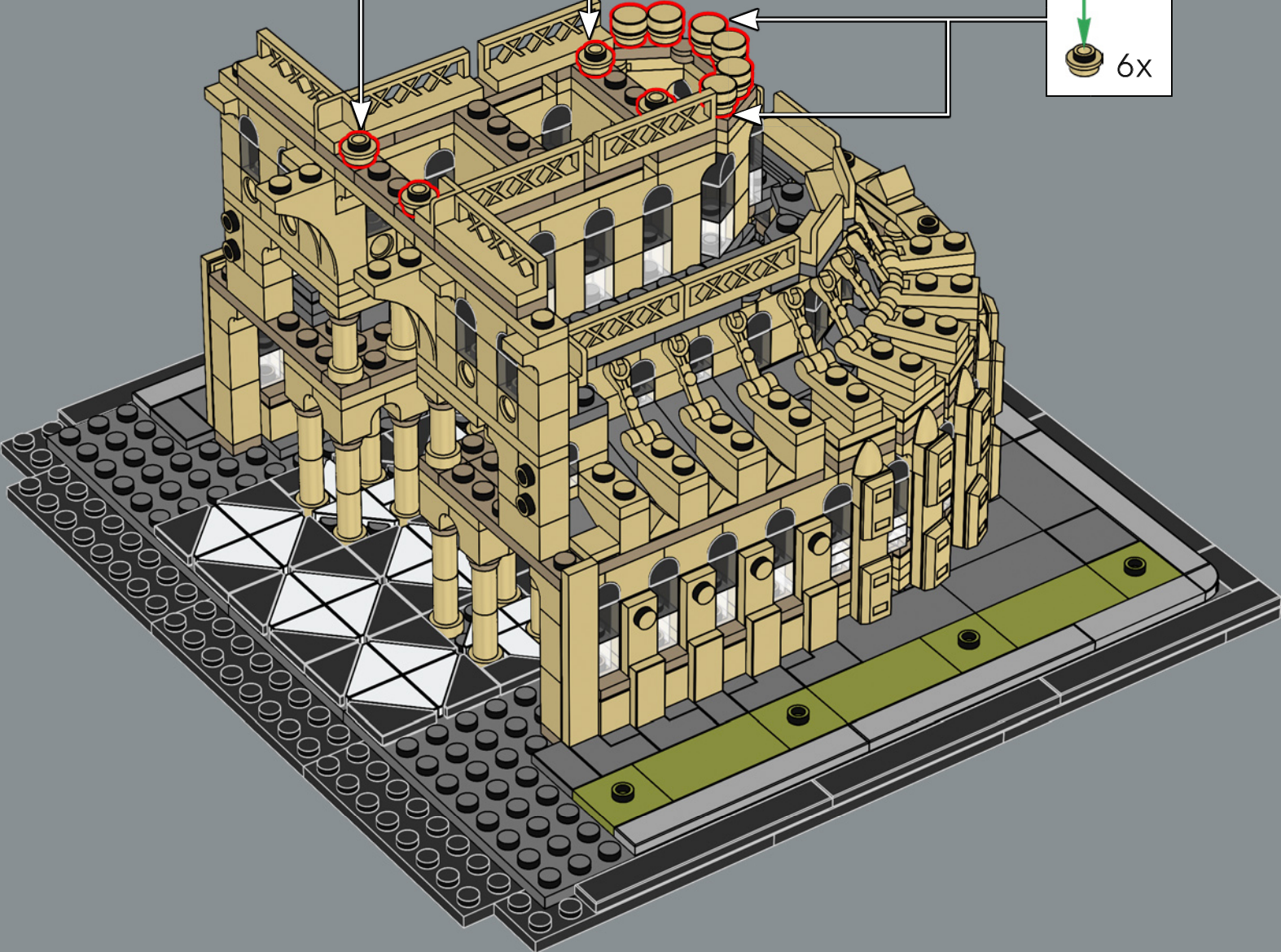

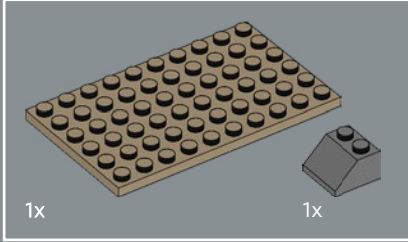
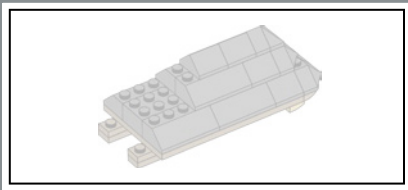

108

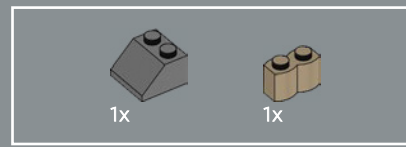
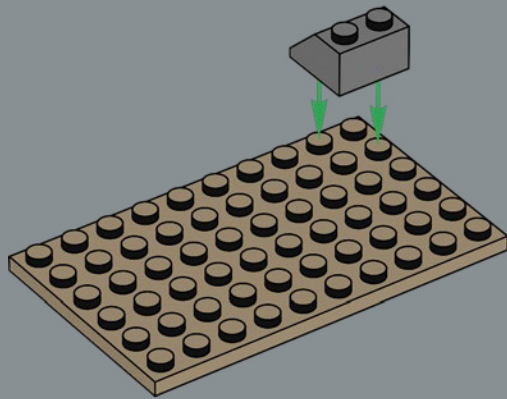

109

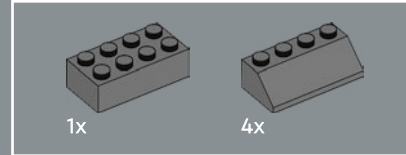
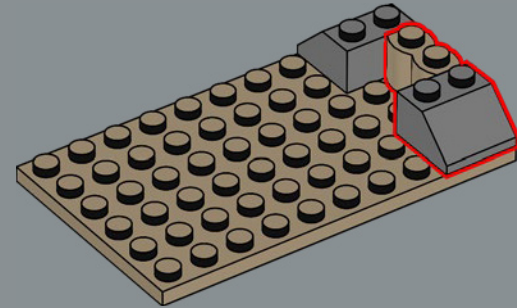

110

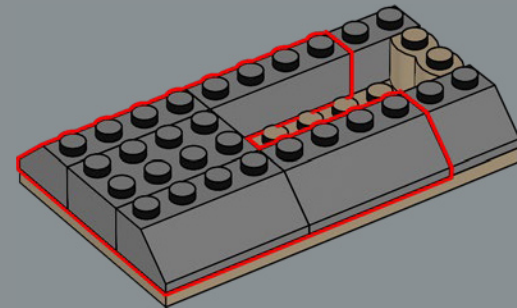



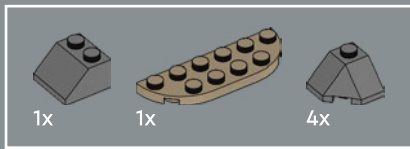

111

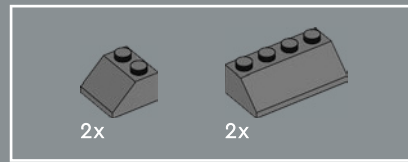
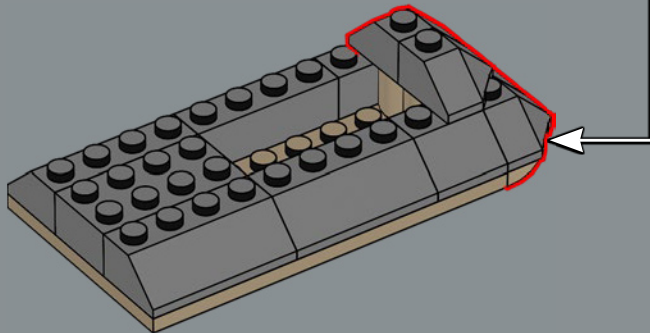

112

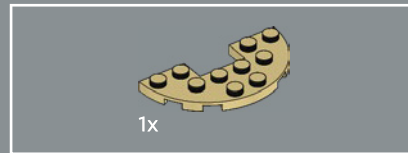
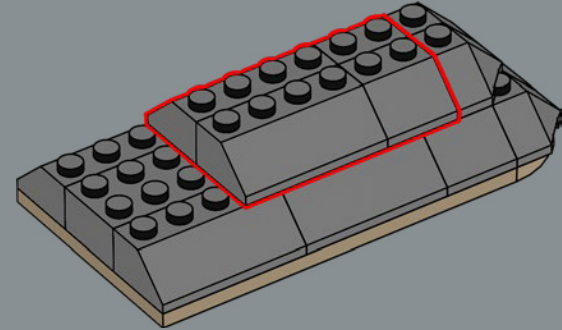

113

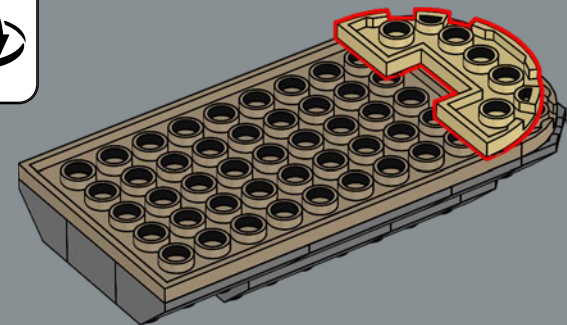

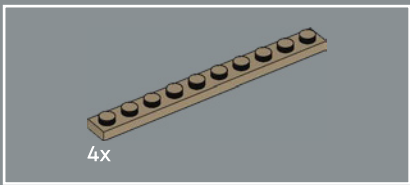

114

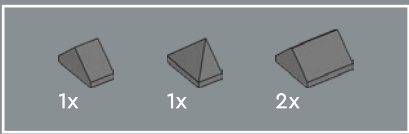
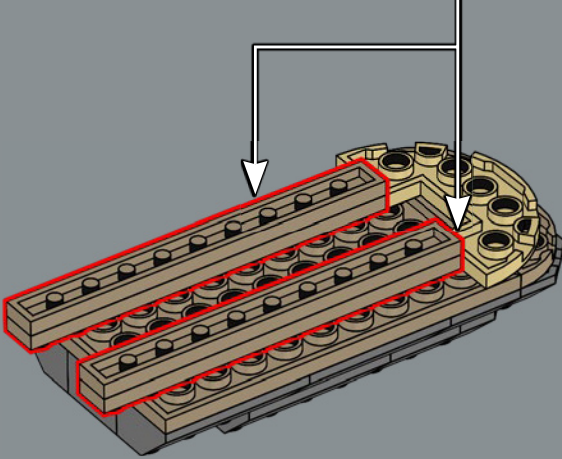
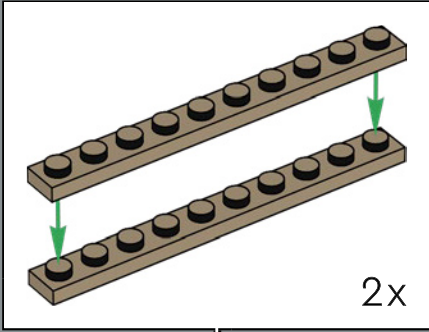

115

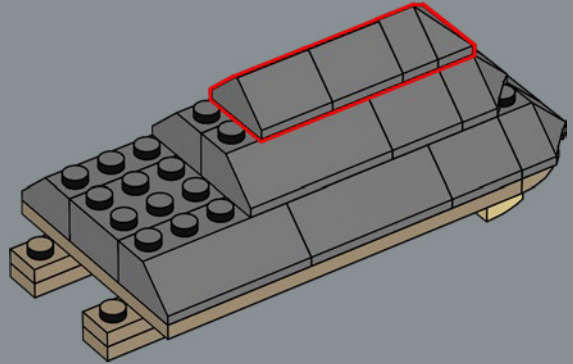

116

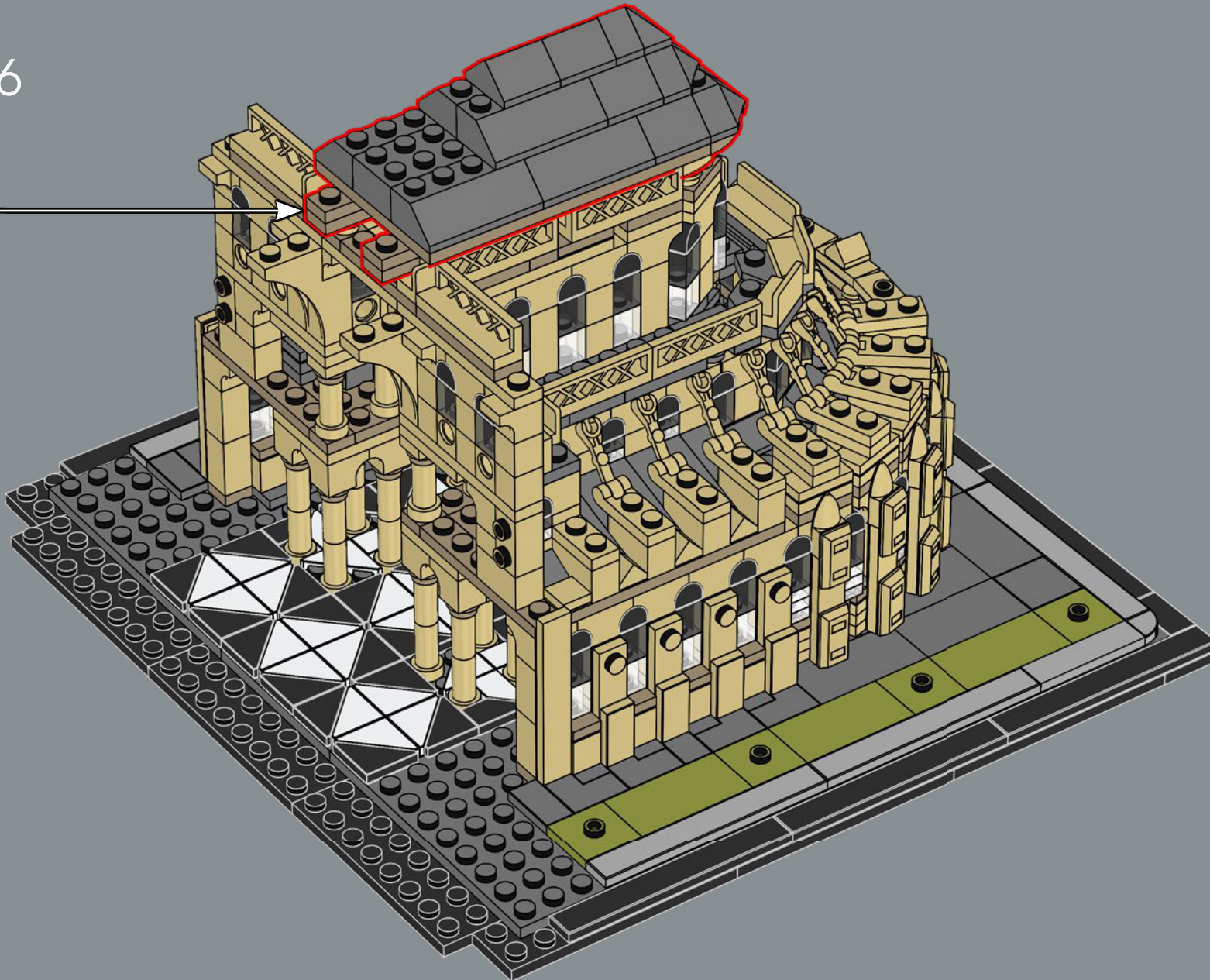

1177: Der Chor und das Chorhaupt sind fast fertig. Es fehlen nur noch die hohen Gewölbe. Das Dach und das hölzerne Tragwerk werden vor den Gewölben gebaut, um Schutz vor Verwitterung zu bieten.

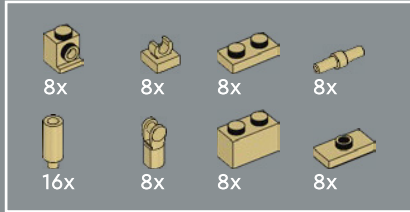
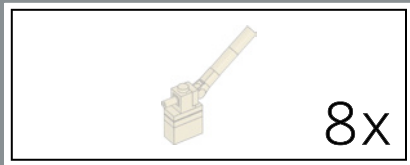

117

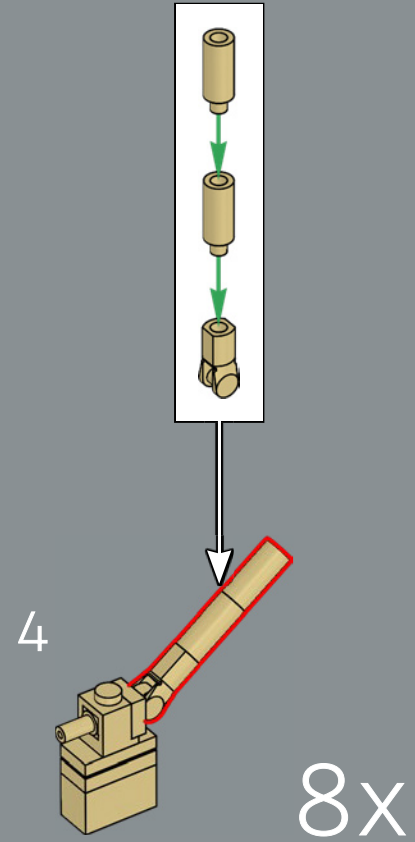
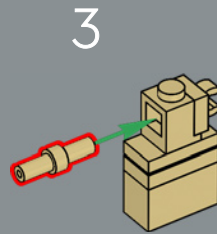
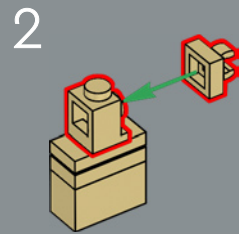
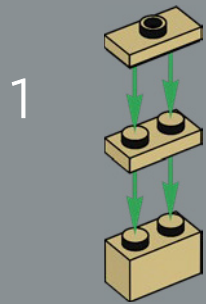

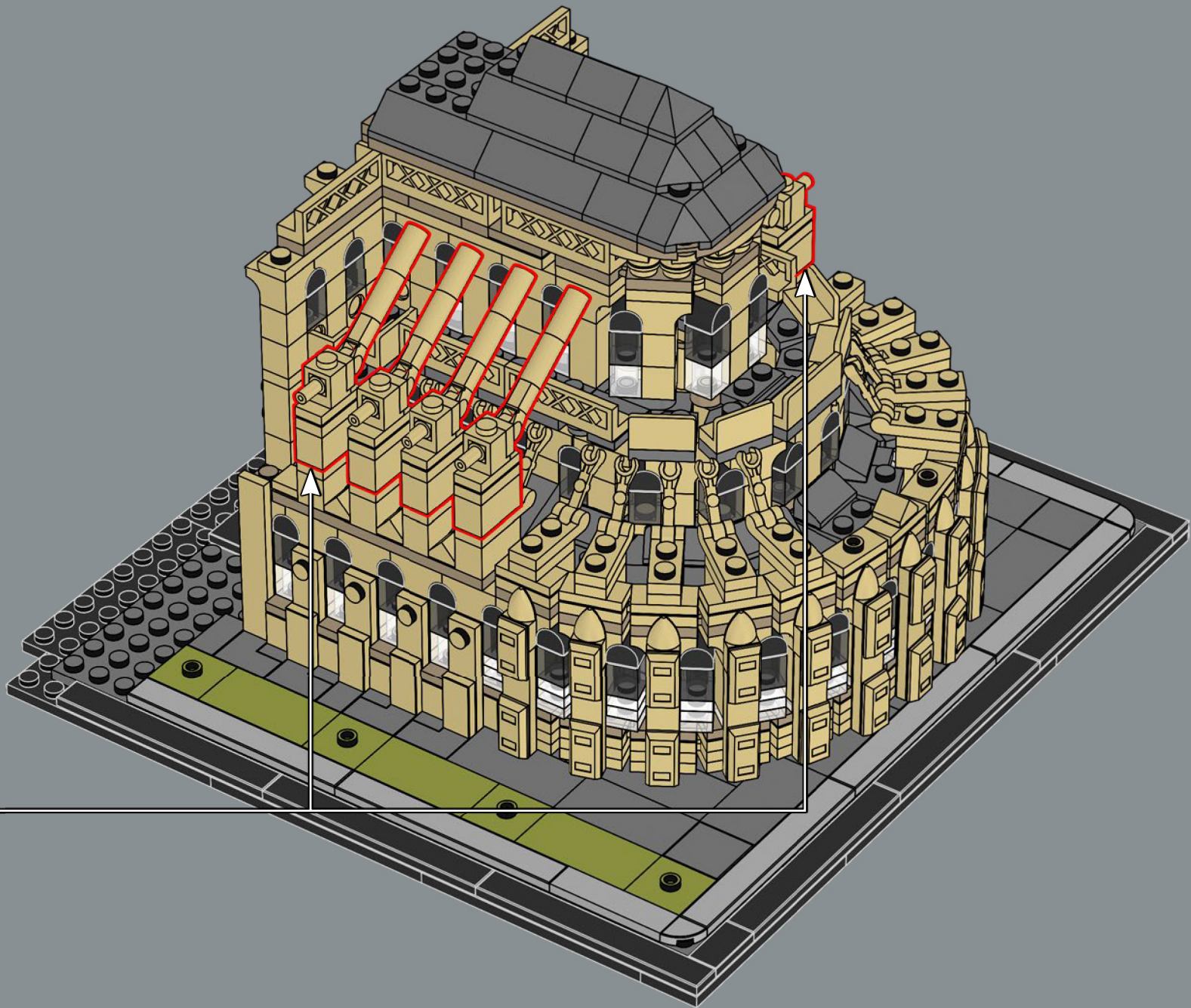

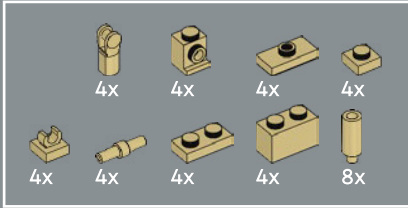
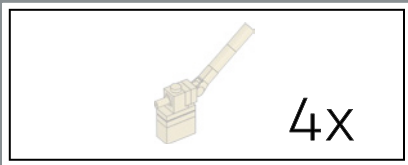

118

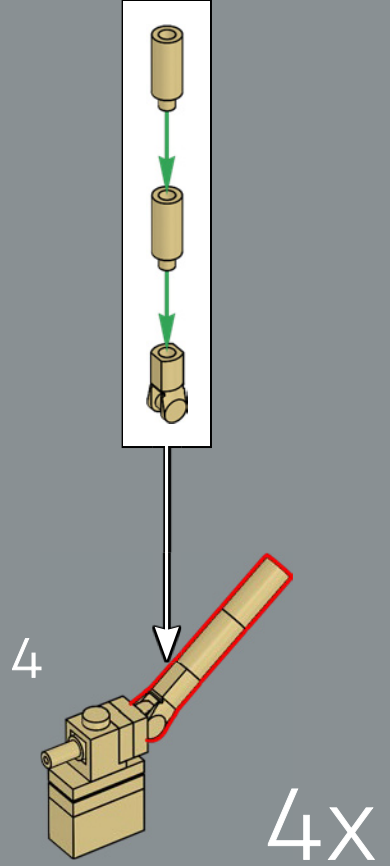
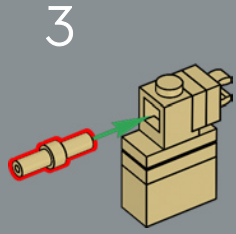
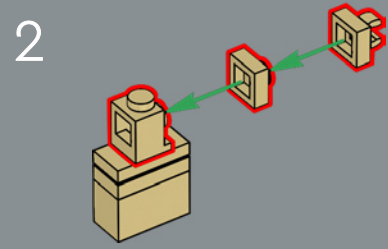
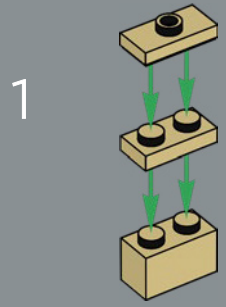

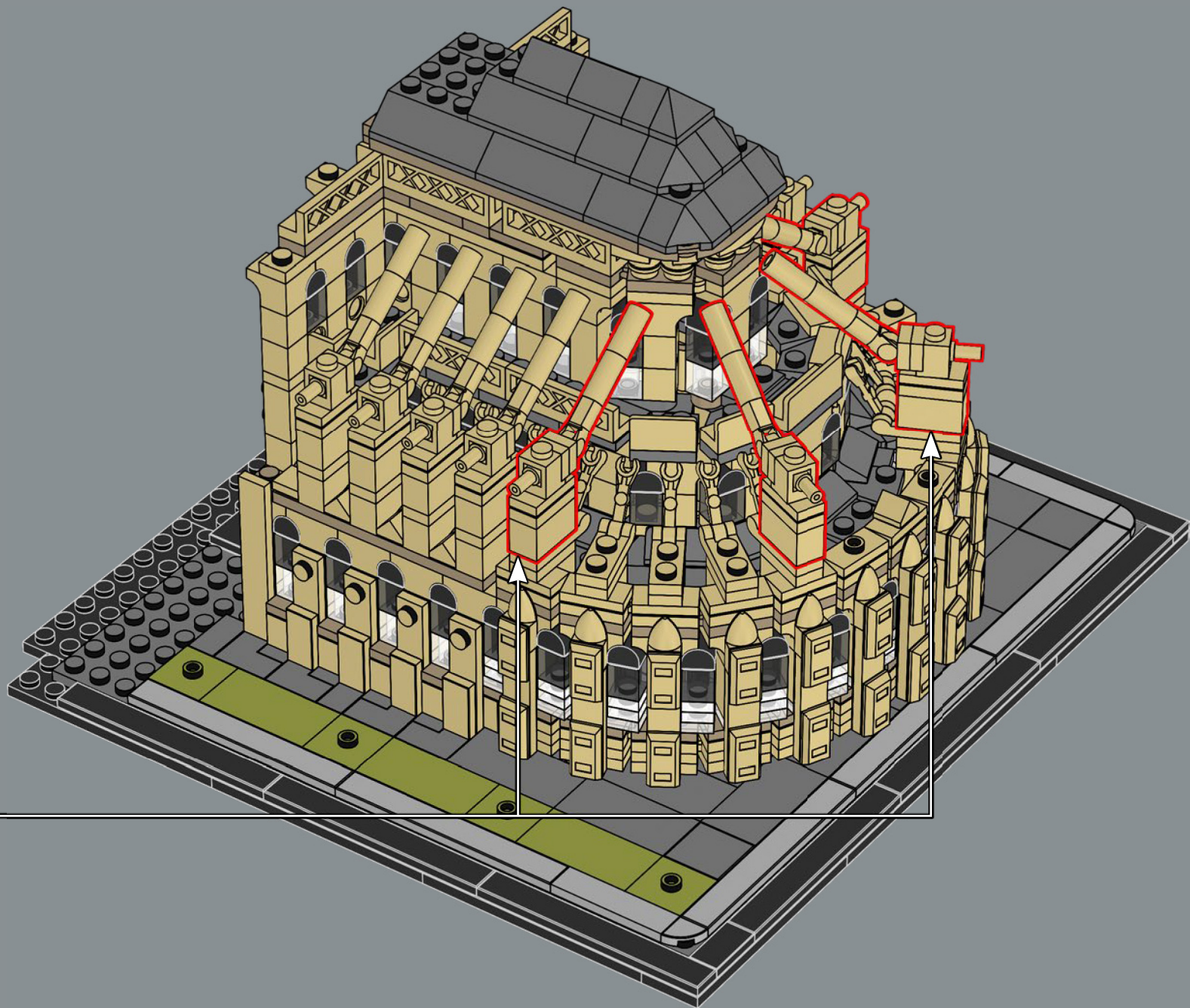

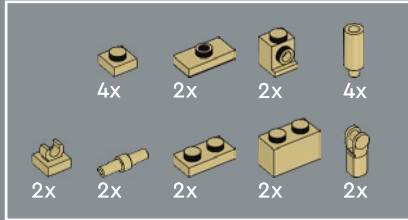
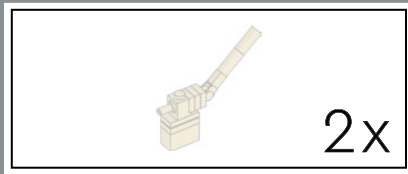

119

Die Notre-Dame de Paris ist die erste Kathedrale, in der die für die gotische Architektur typischen Strebebögen vollständig integriert sind.

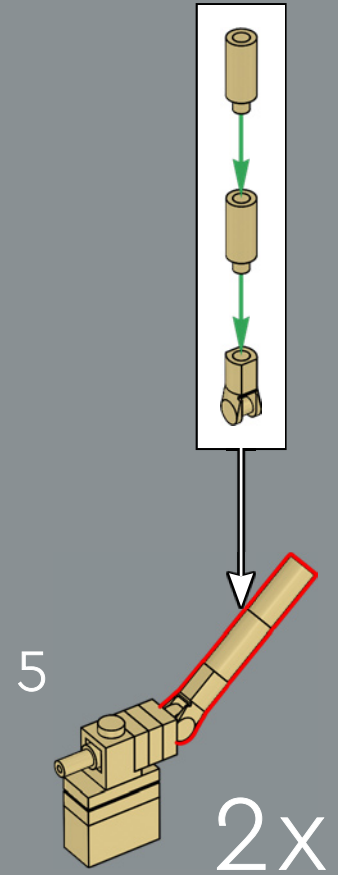
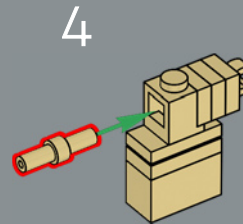
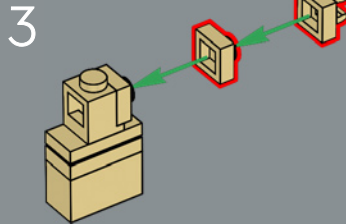
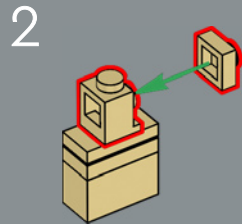
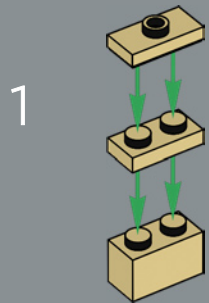



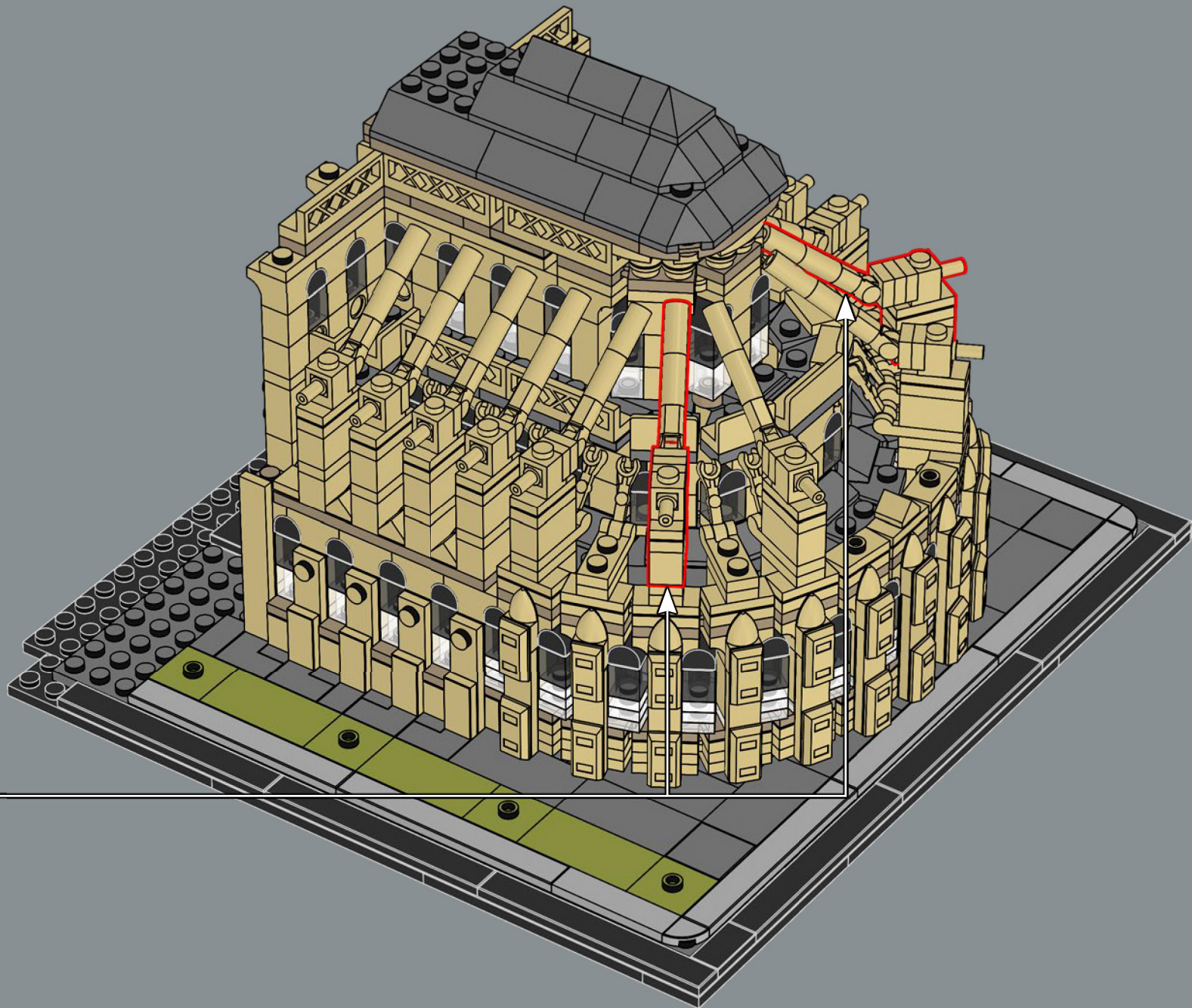

# EIN LEGO® WAHRZEICHEN NIMMT GESTALT AN



*Die Bauarbeiten werden im Querschiff und  
in den Erkern an der Südseite des Hauptschiffs fortgesetzt.*

✚ Die Kathedrale Notre-Dame de Paris wurde am Standort der bestehenden Kathedrale auf der Île de la Cité in der Seine errichtet. Das Bauwerk ist 128 Meter lang, 48 Meter breit und 69 Meter hoch. Der zuerst fertiggestellte östliche Abschnitt wurde schon vorübergehend als Kirche genutzt, während die Bauarbeiten am Querschiff und an den ersten Erkern auf der Südseite des Hauptschiffs weitergingen. In das ursprünglich im romanischen Baustil geplante Bauwerk flossen allmählich zeitgenössische Architekturstile ein, aus denen letztendlich das gotische Gebäude hervorging, das wir heute kennen. Dieses Modell bleibt sowohl der inneren Konstruktion als auch den äußeren architektonischen Details treu, wobei bestimmte Merkmale in kleinerem Maßstab dargestellt sind, um den imposanten Anblick nachzubilden, mit dem Besucher in all den Jahrhunderten konfrontiert wurden.

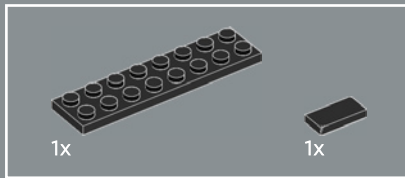
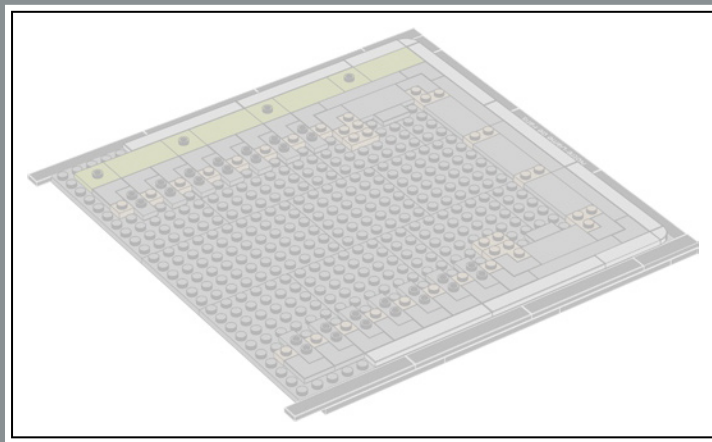

120

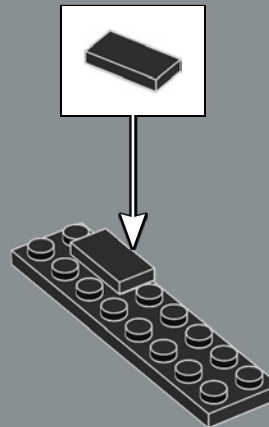

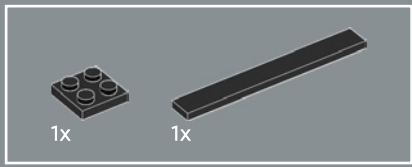

121

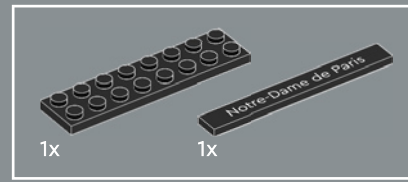
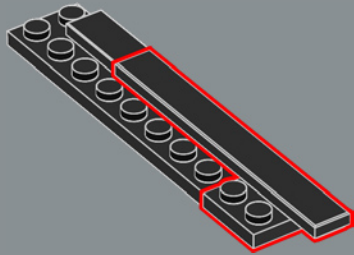

122

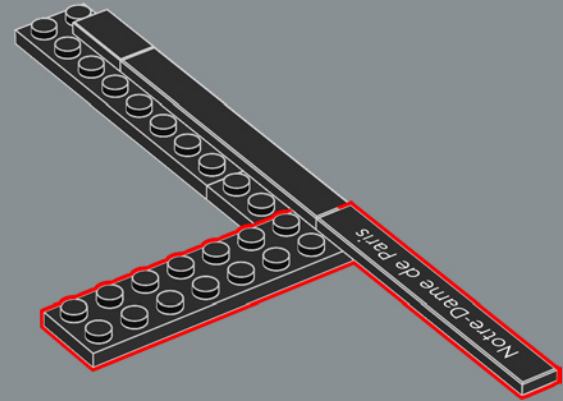

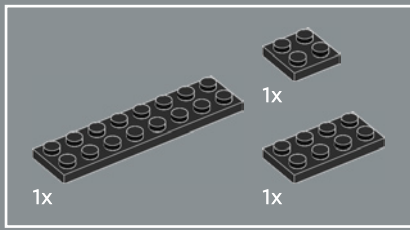

123

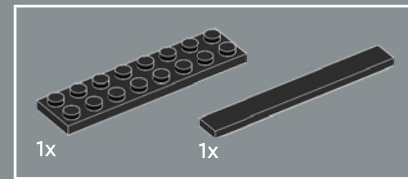
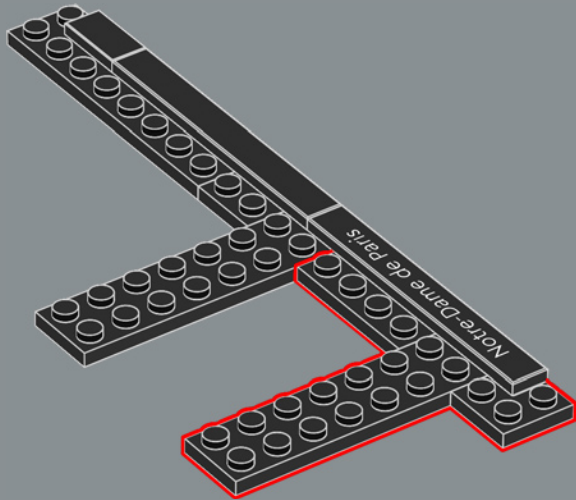

124

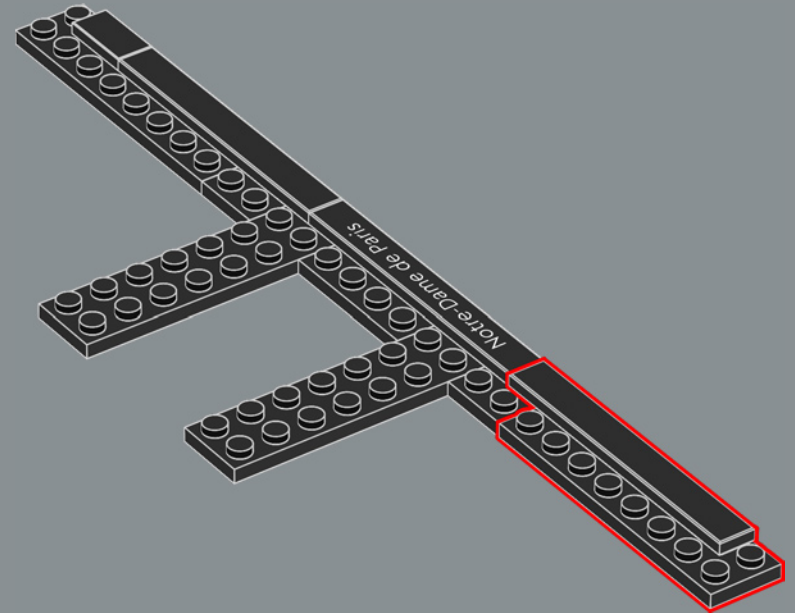

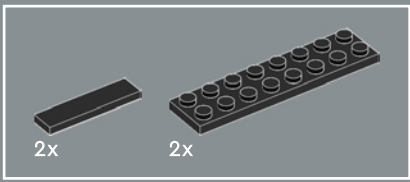

125

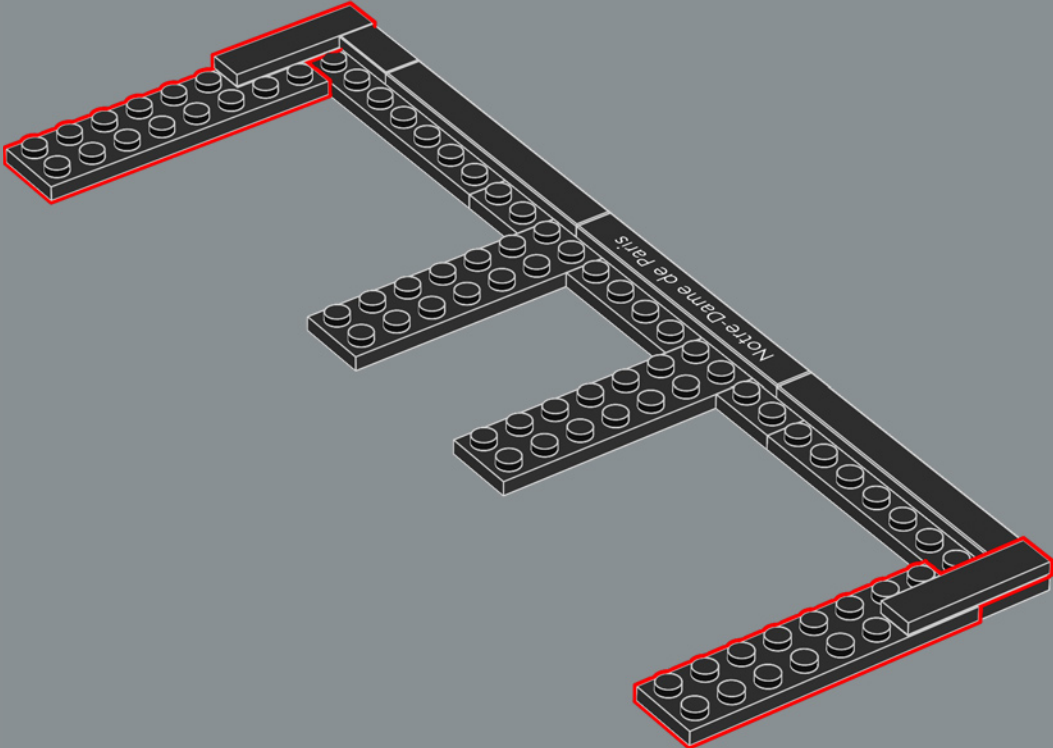

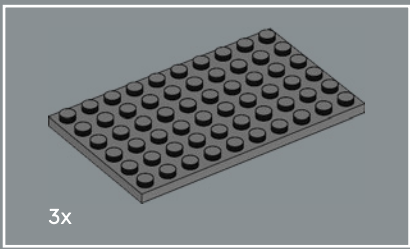

126

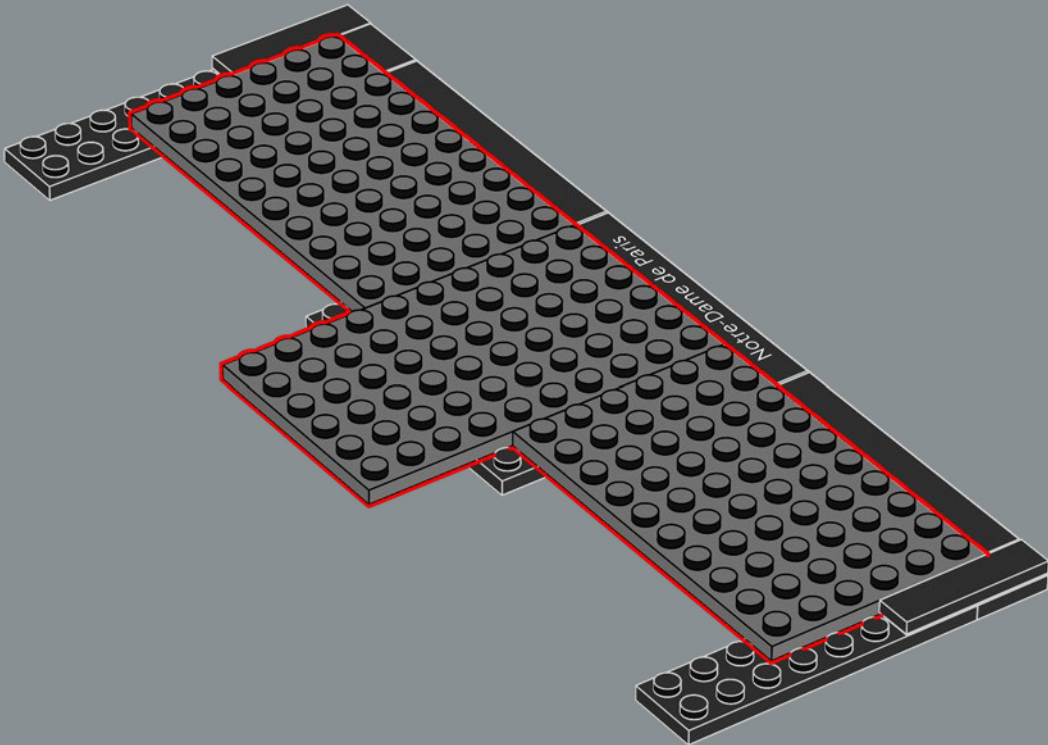

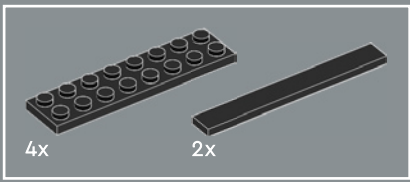

127

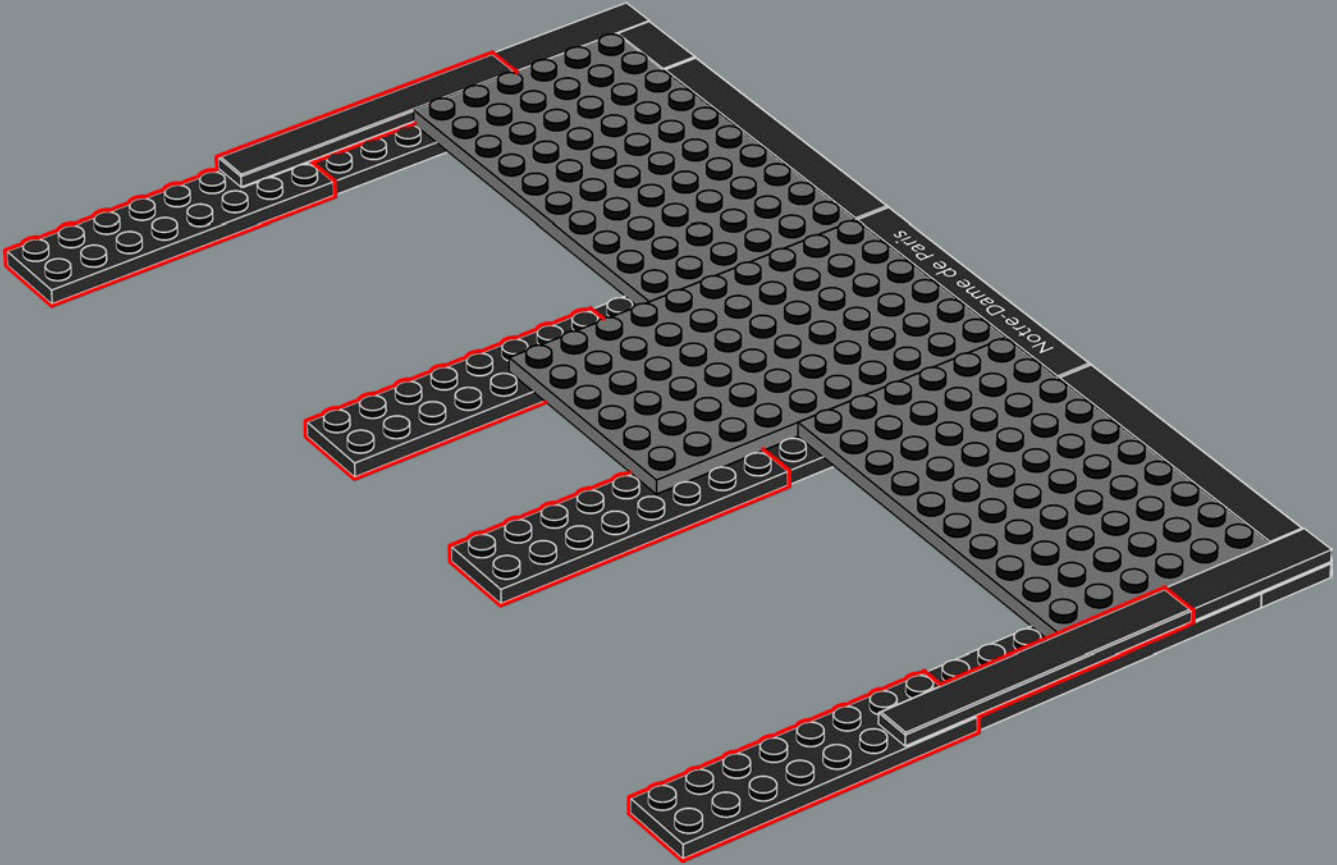



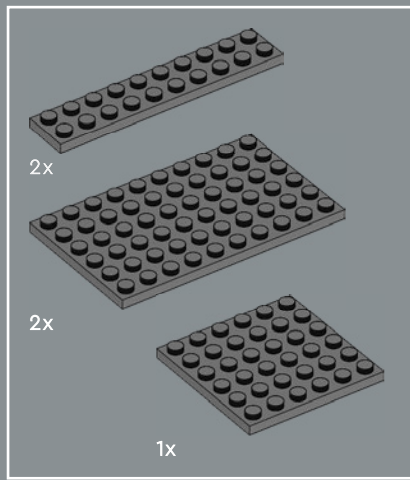

128

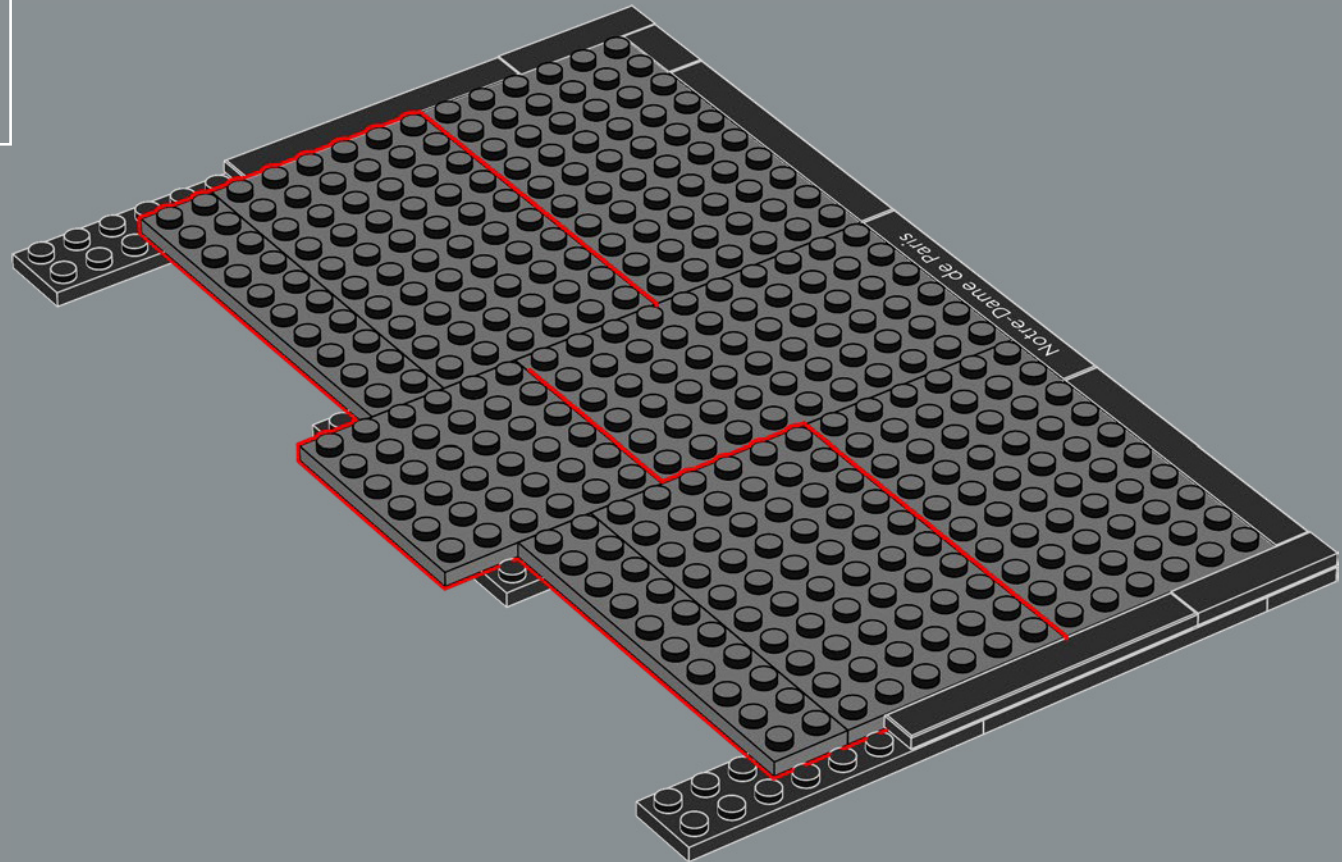

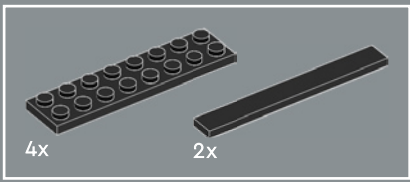

129

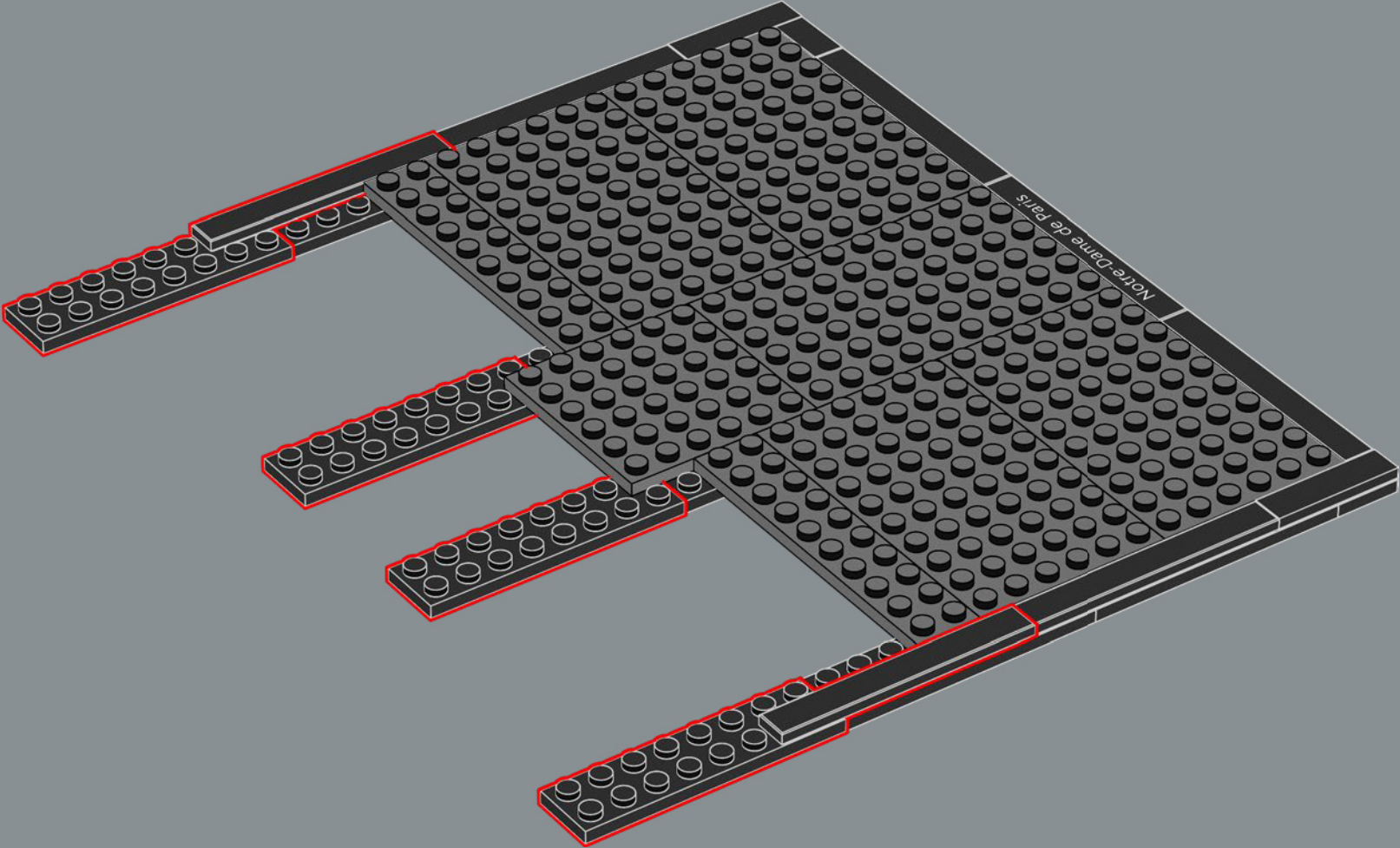

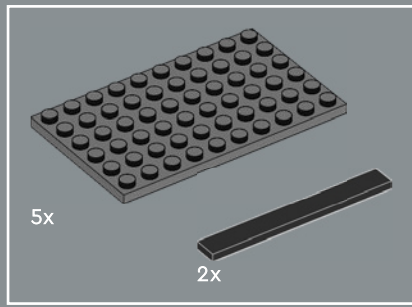

130

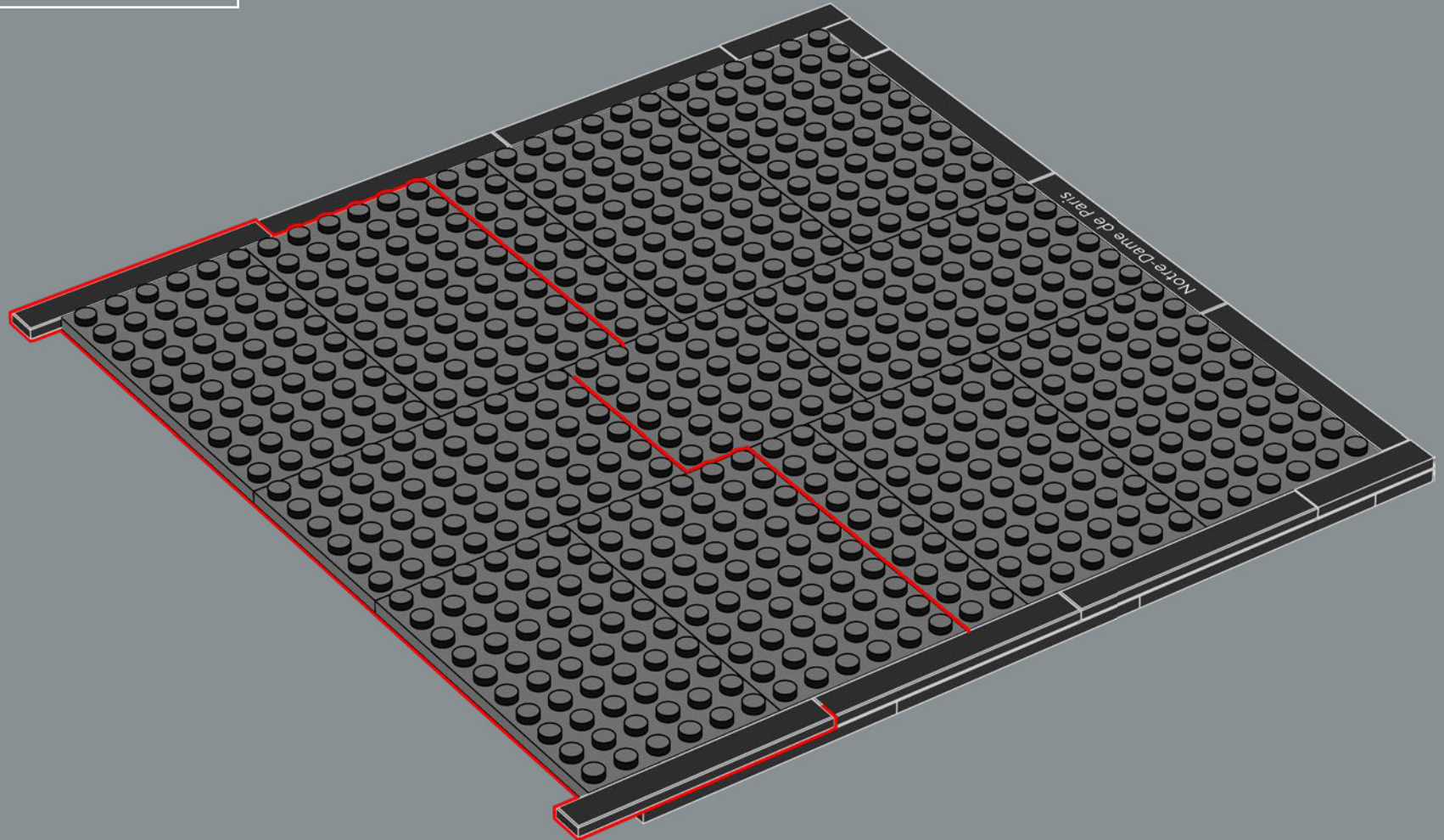



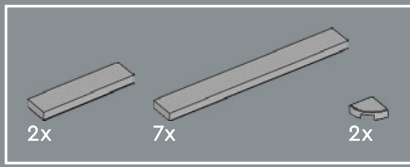

132

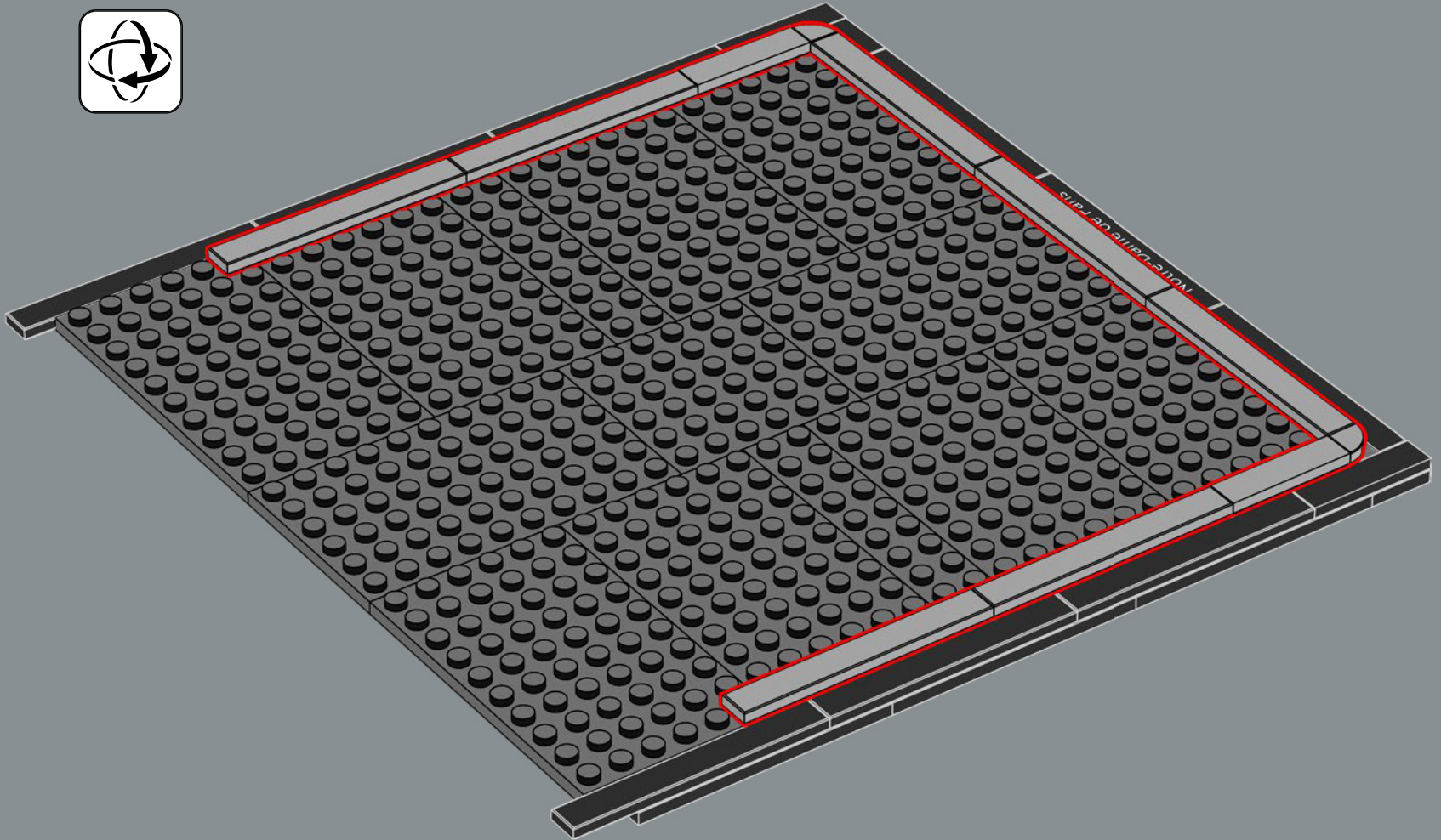

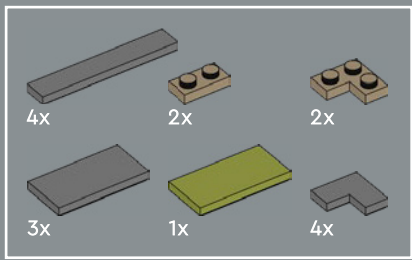

133

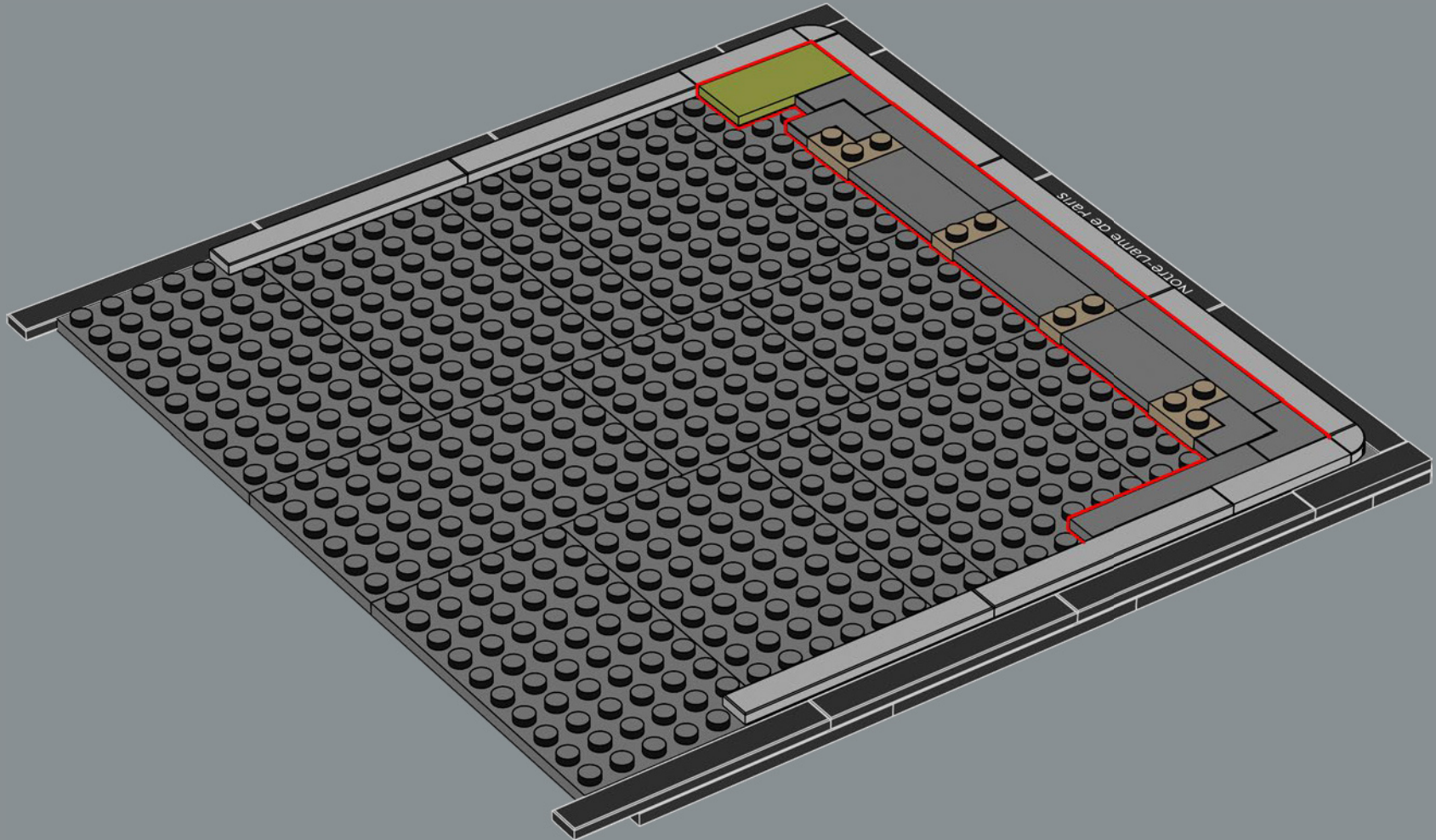

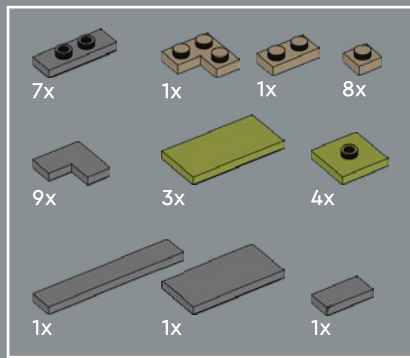

134

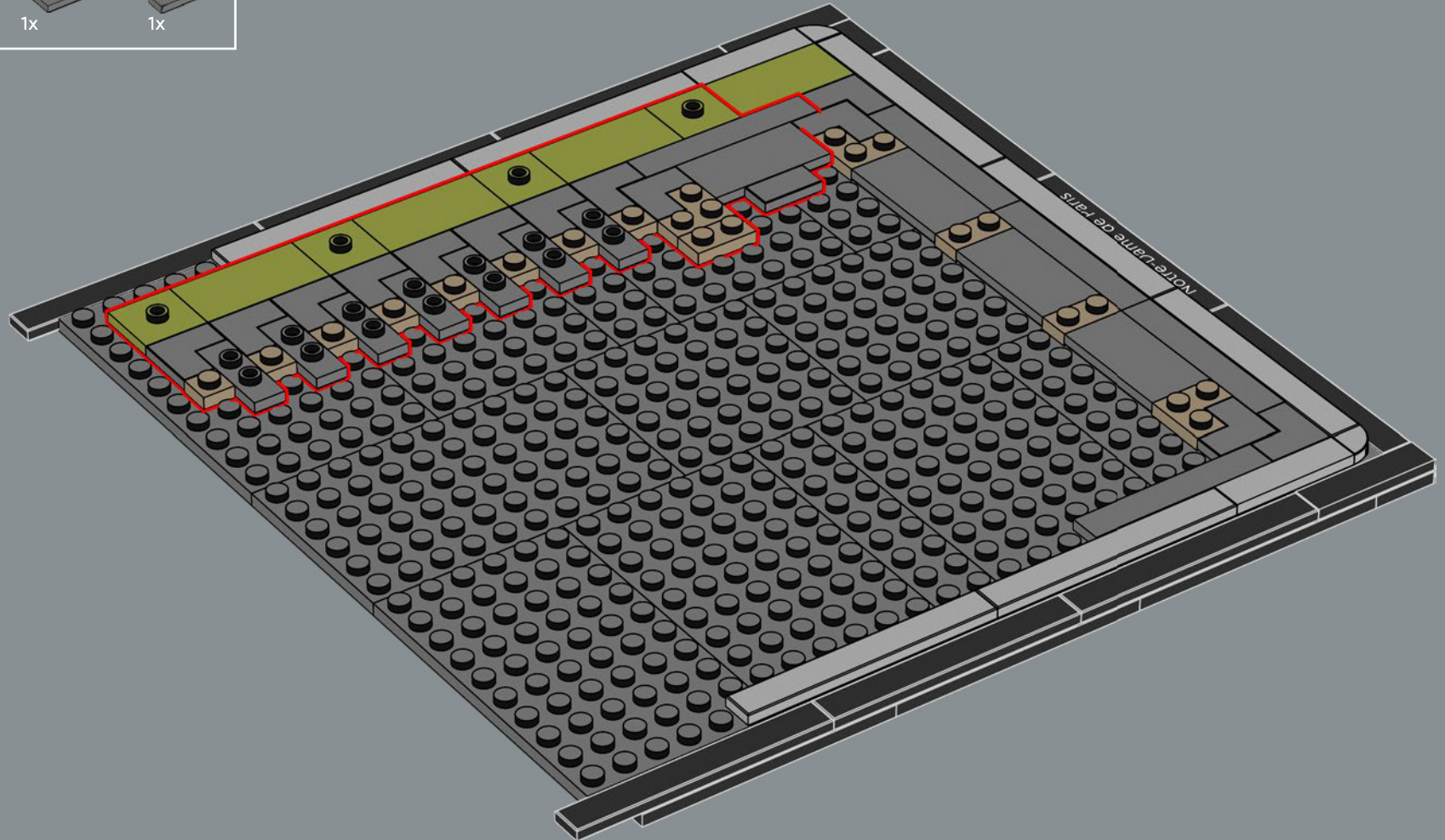

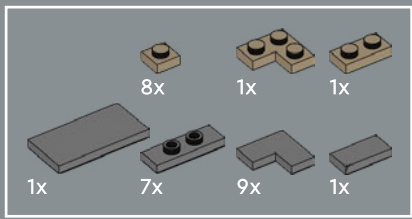

135

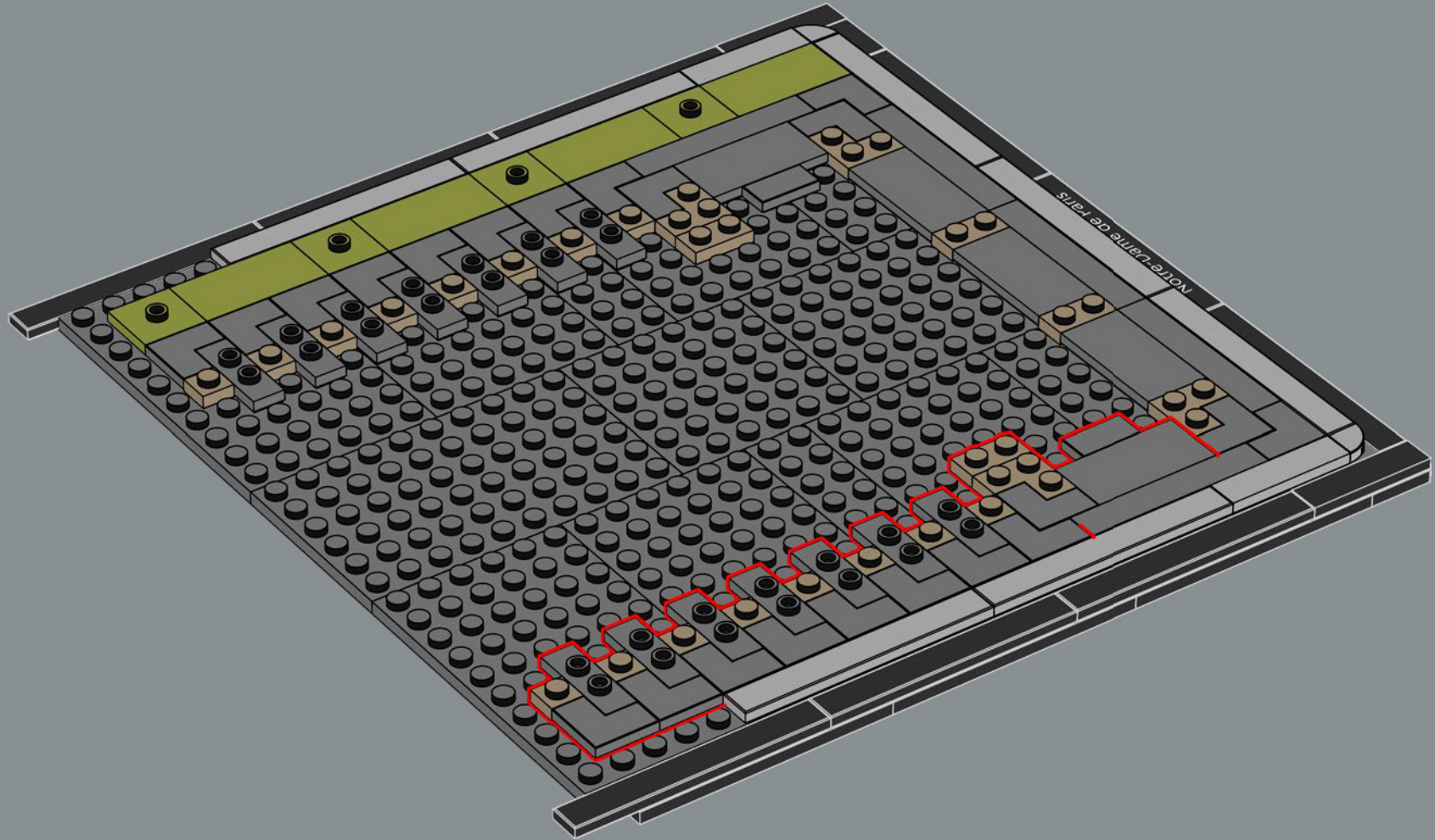



136

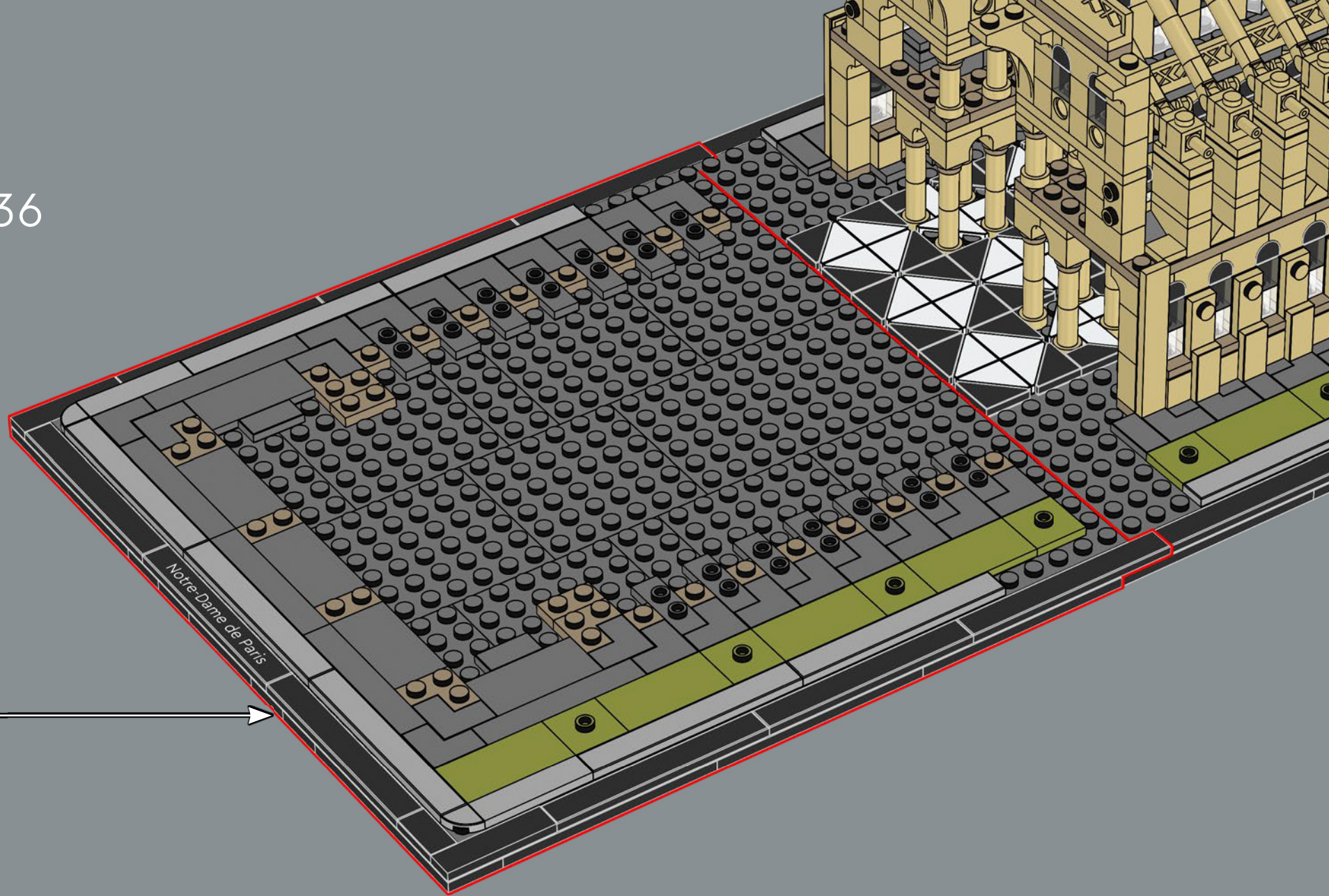

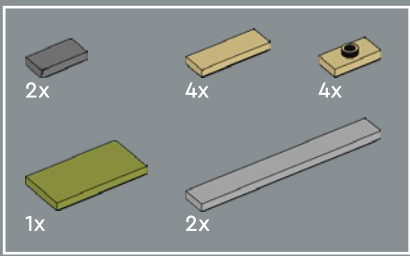

137

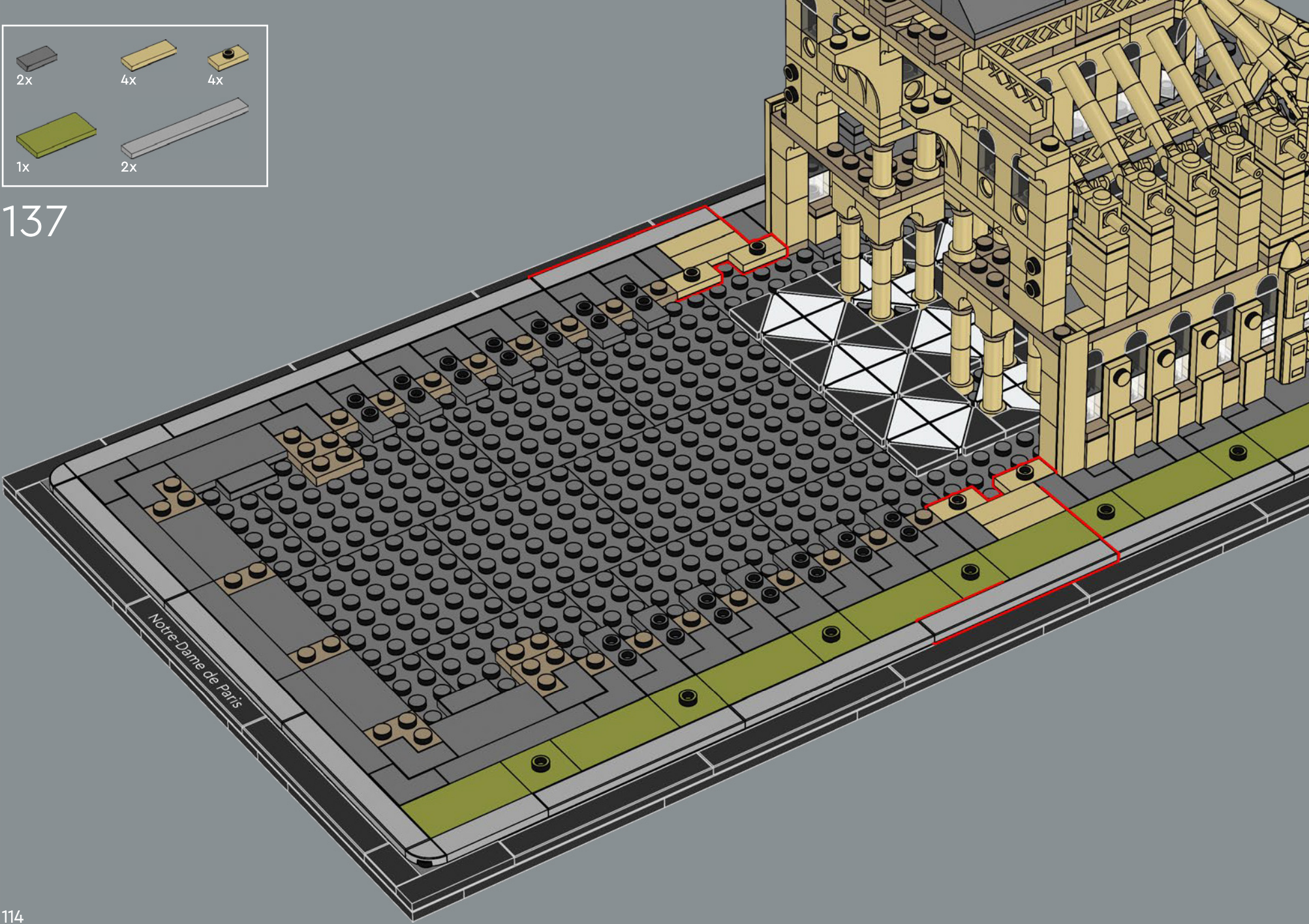

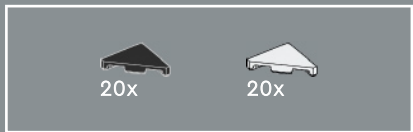

138

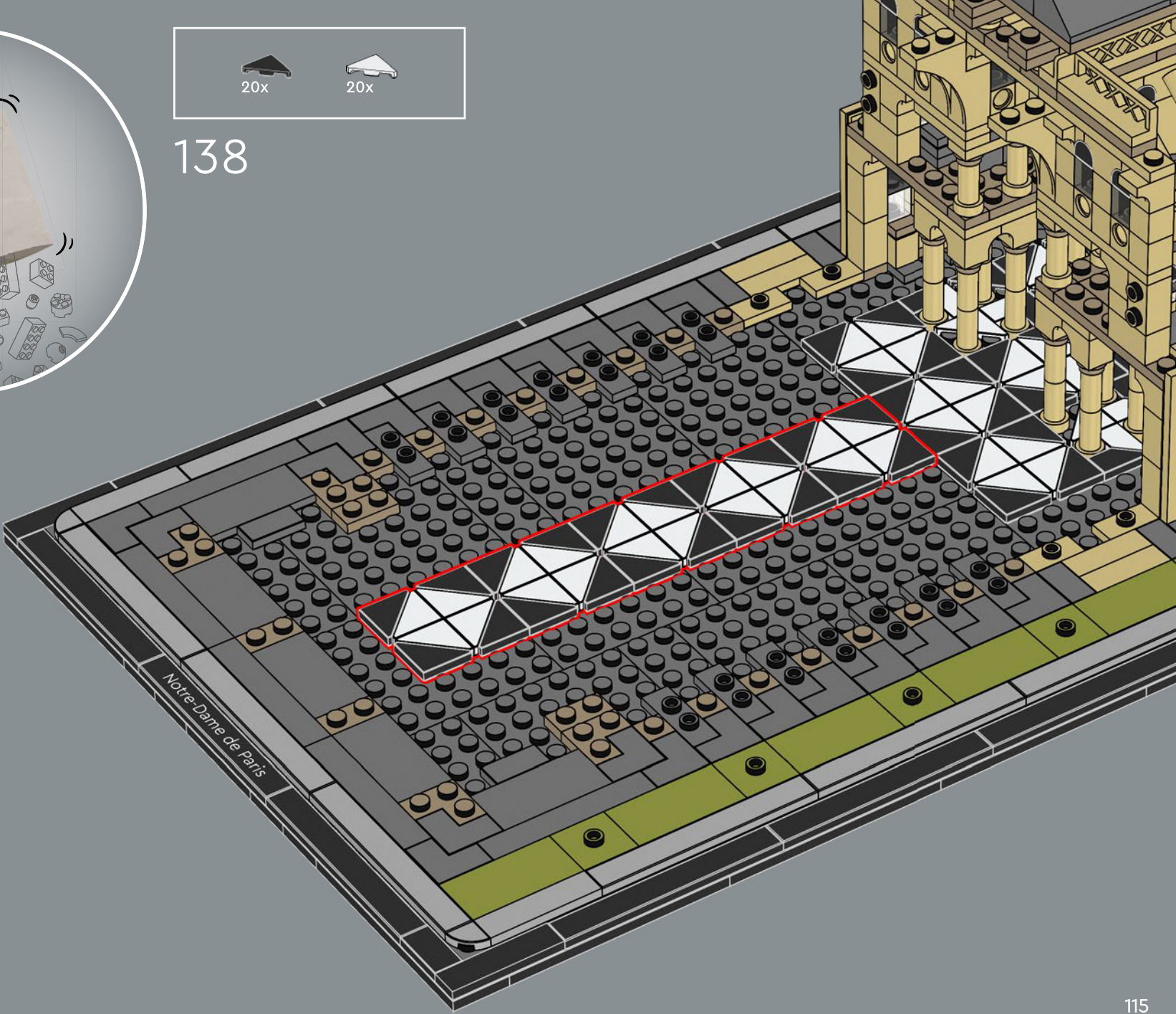

2x 30x

139

30x

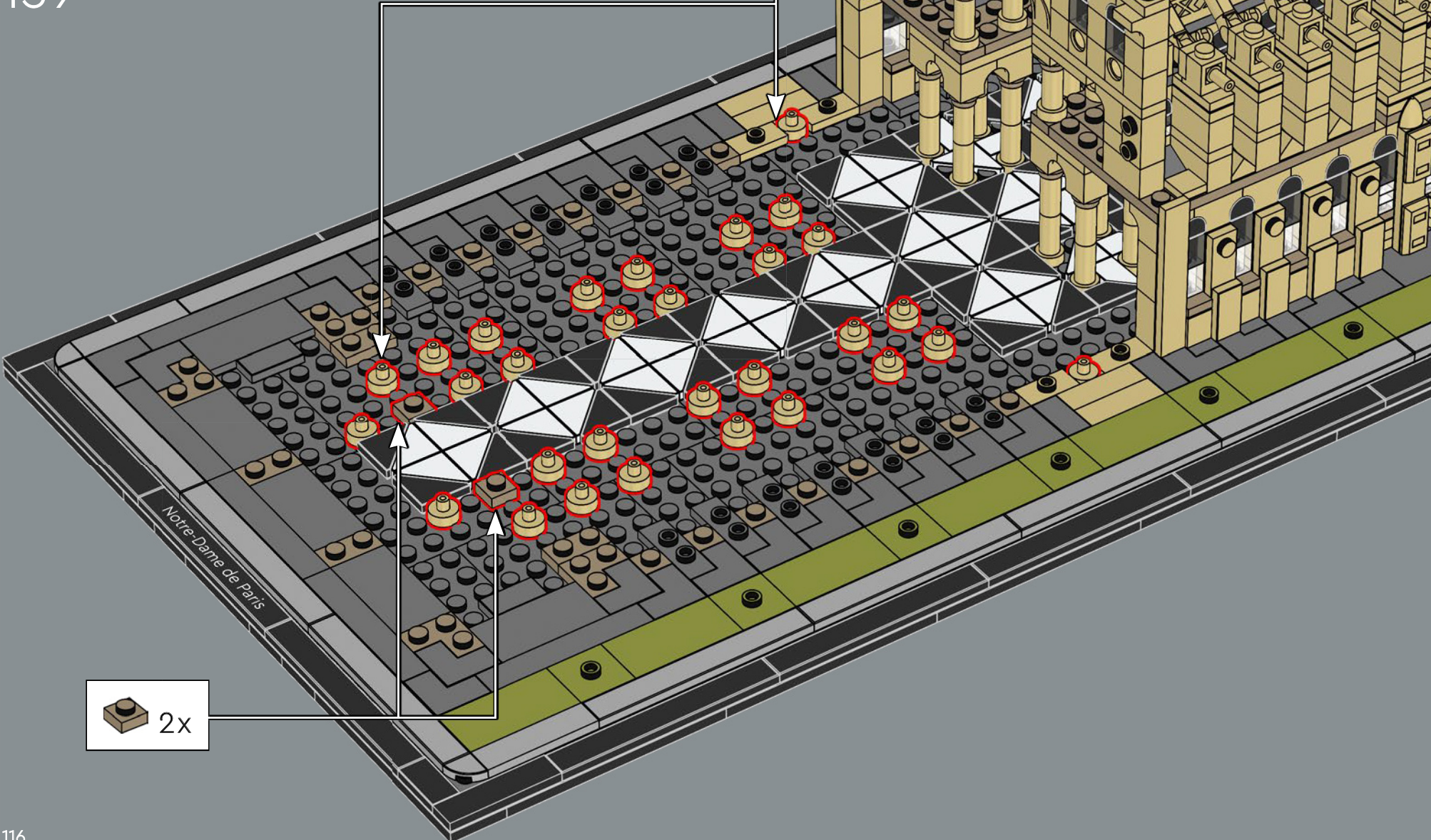

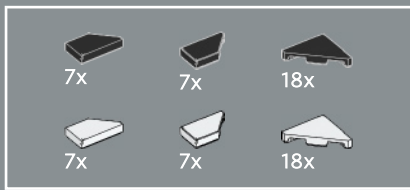

140

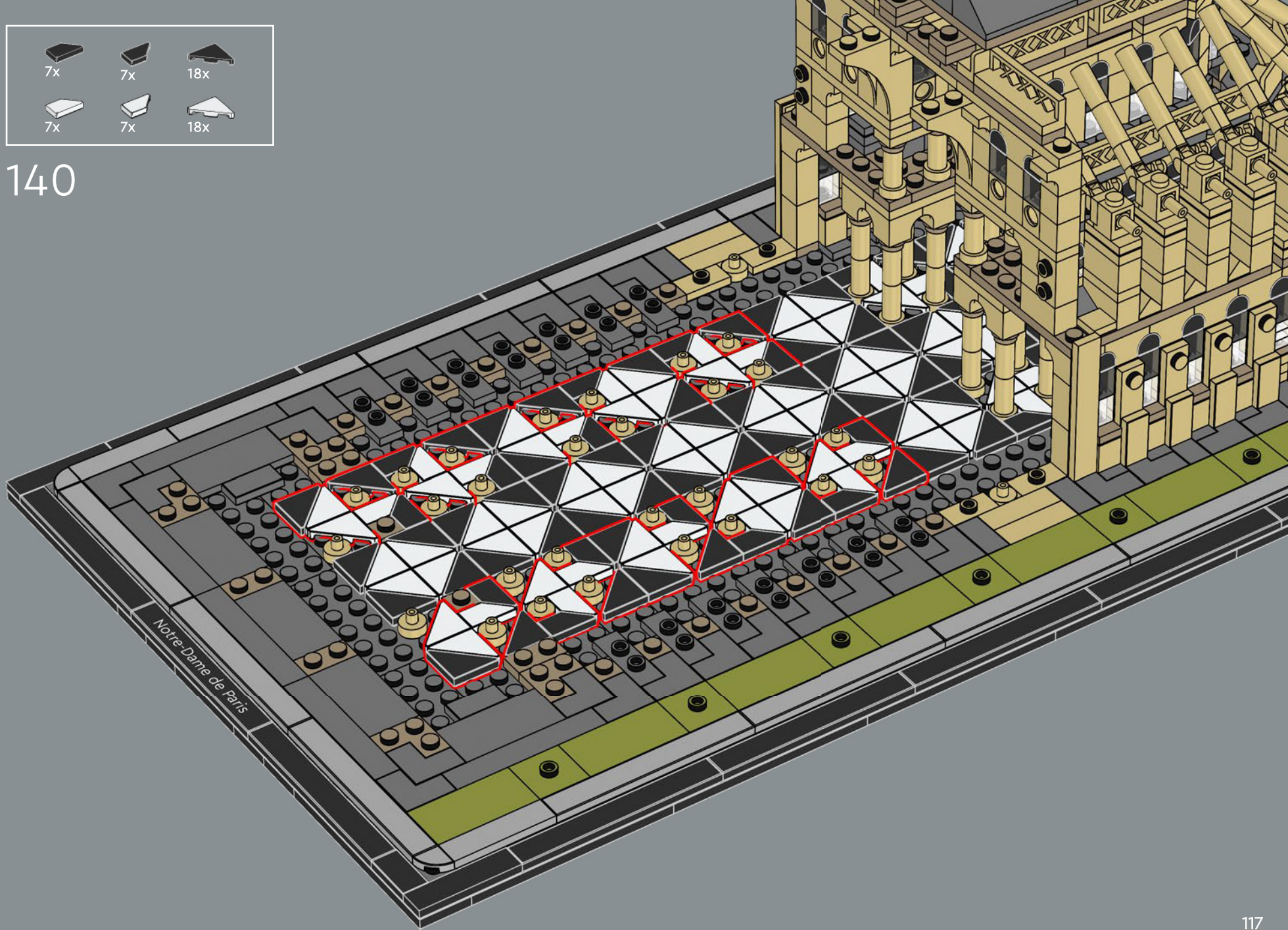



141

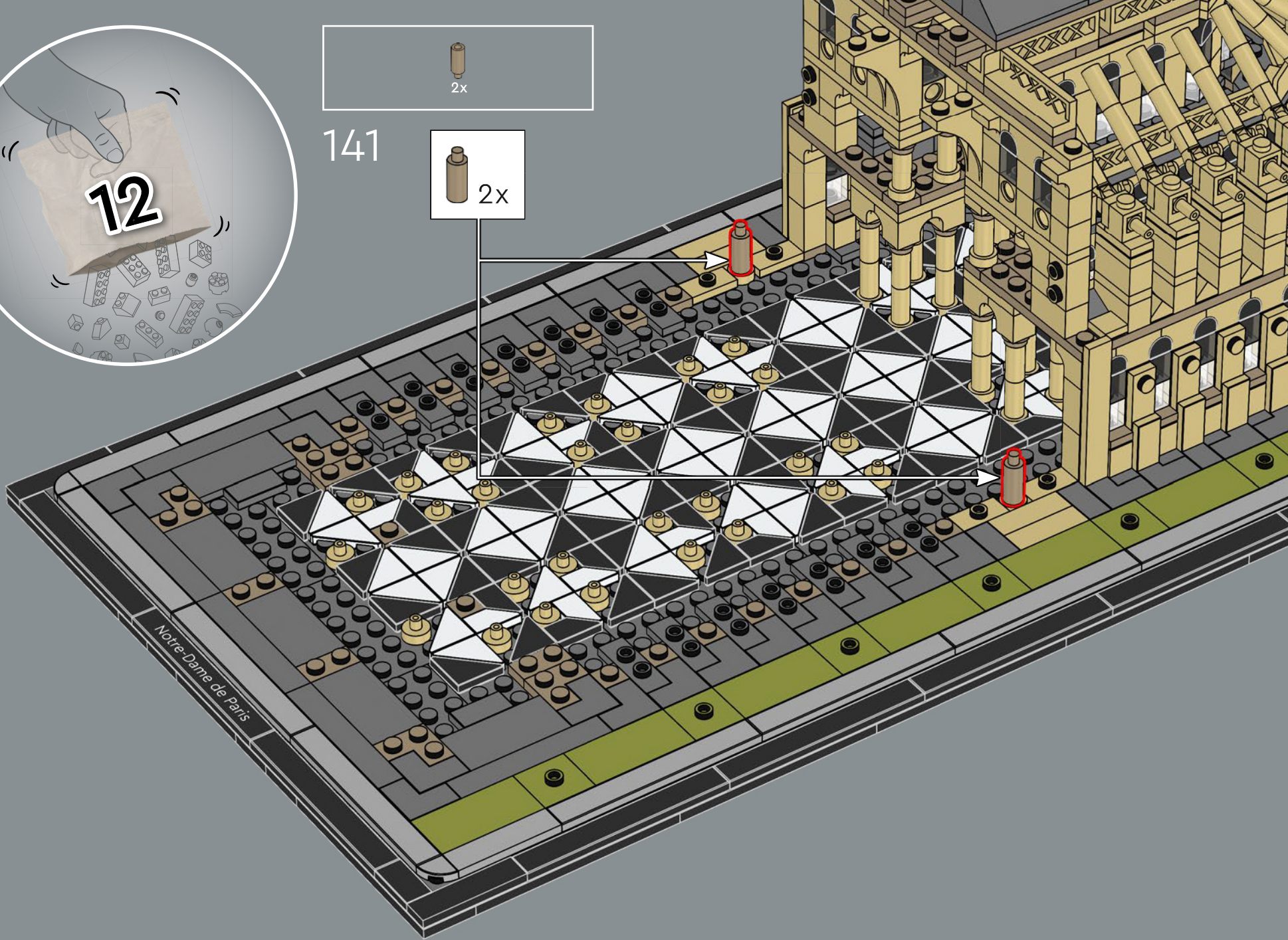
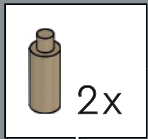

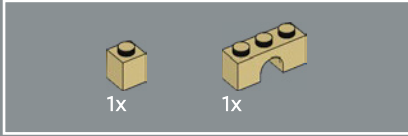
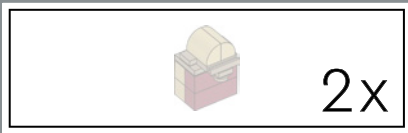

142

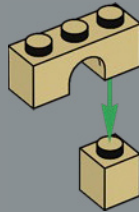

143

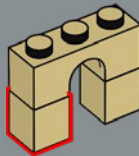

144

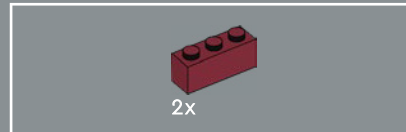
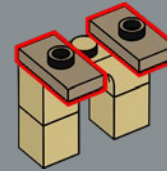

145

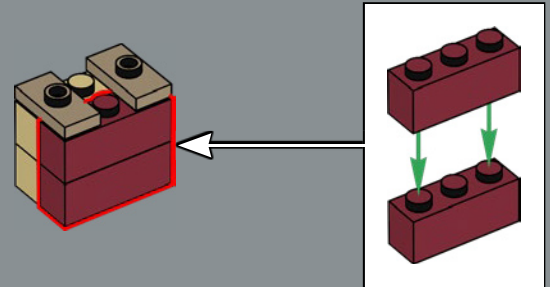

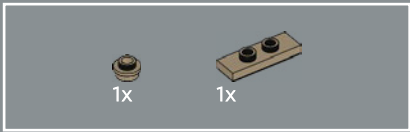

146

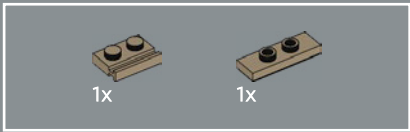
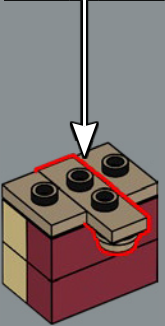
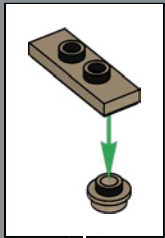

147

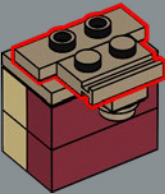

148

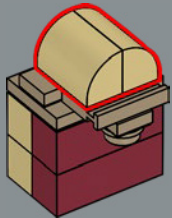

2x



149

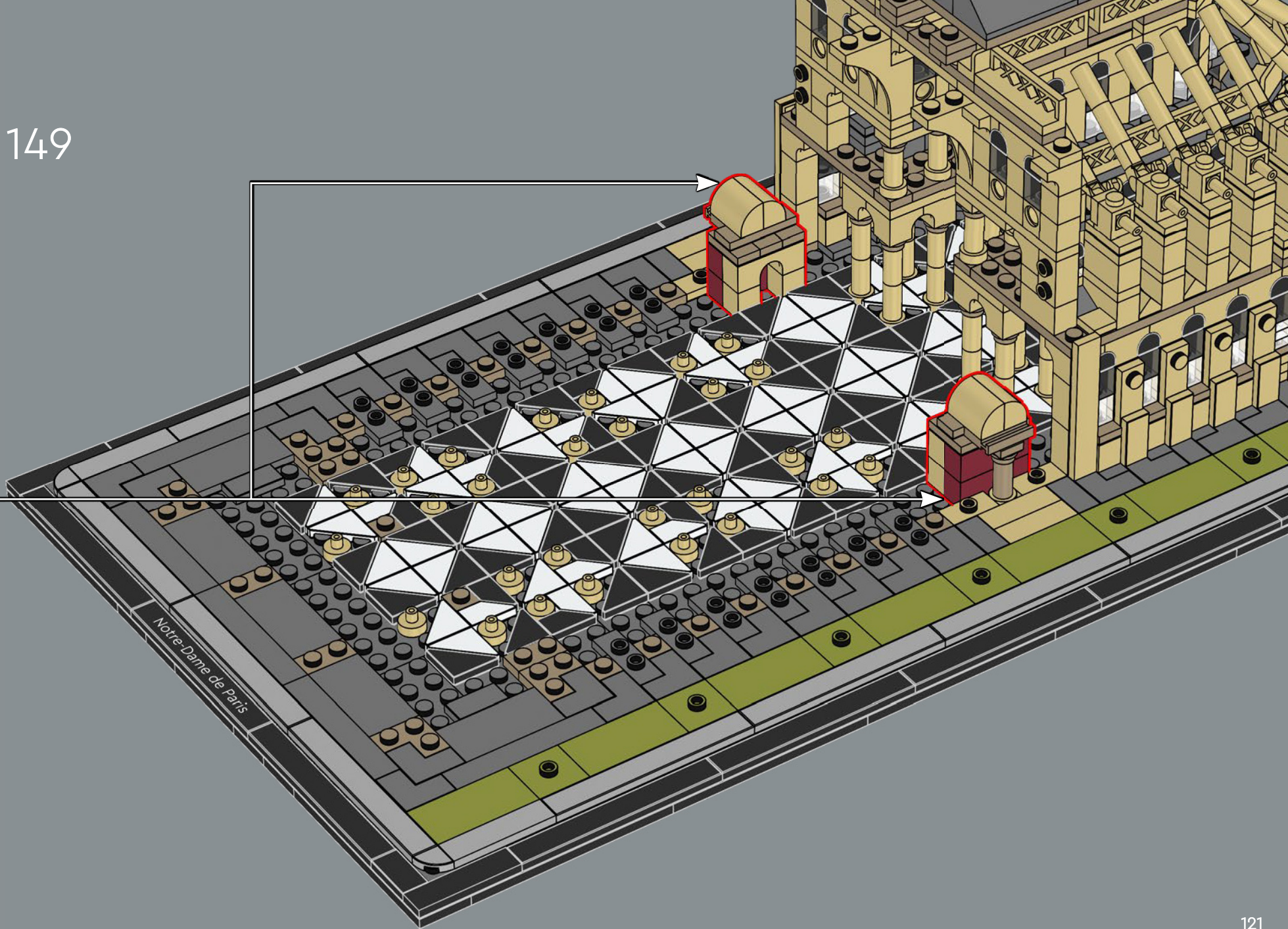

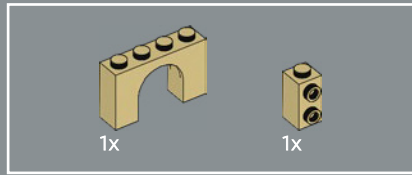
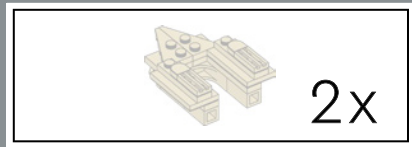

150

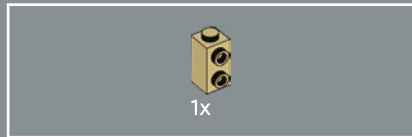
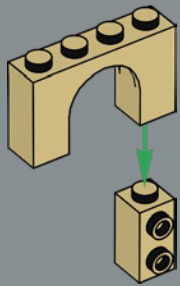

151

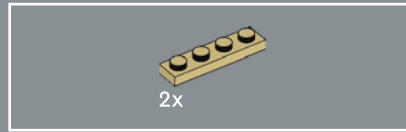
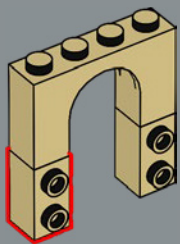

152

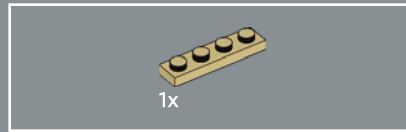
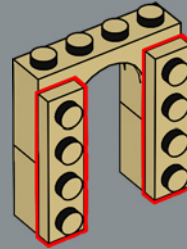

153

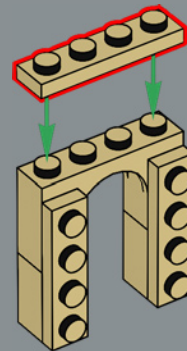

154

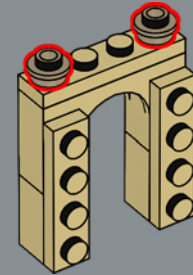

155

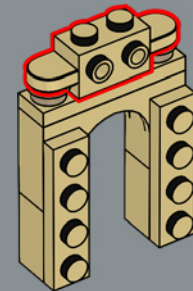

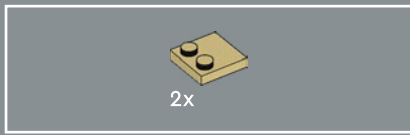

156

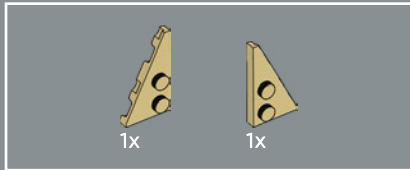
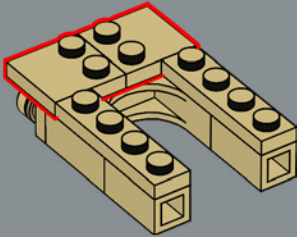

157

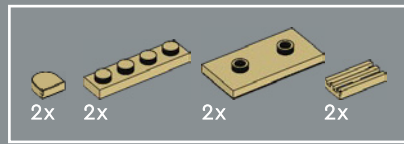
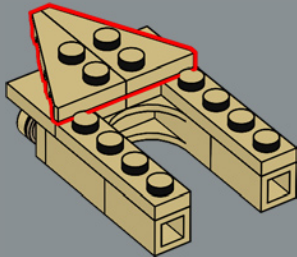

158

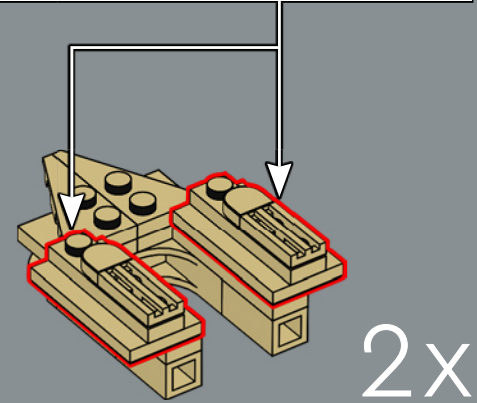
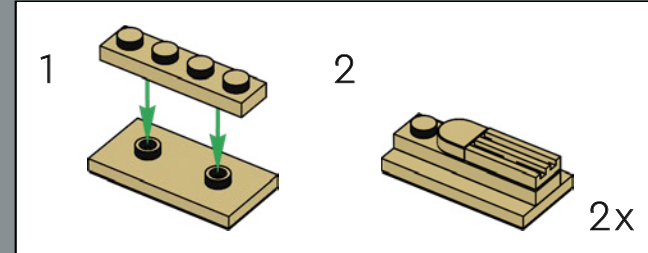

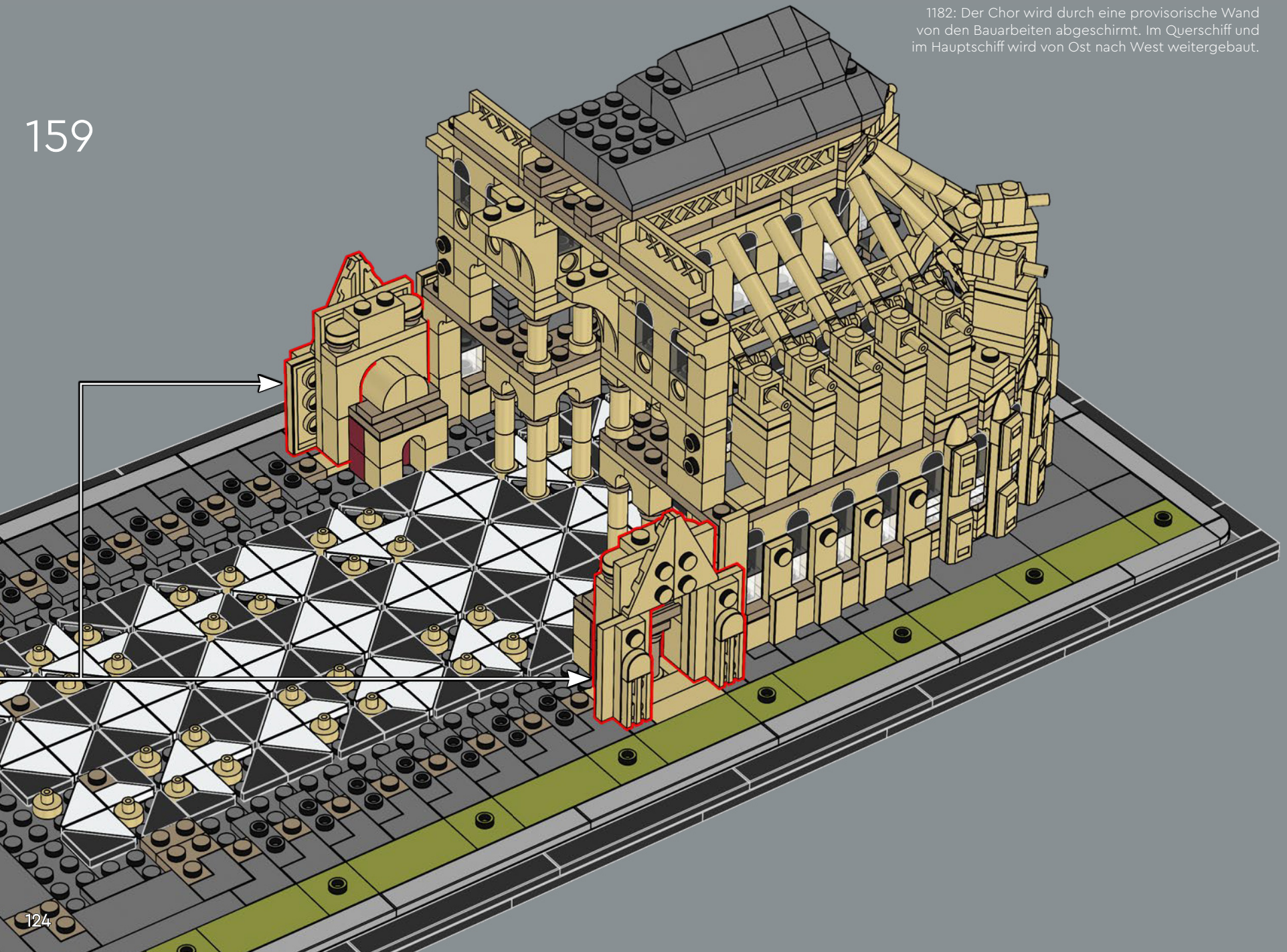

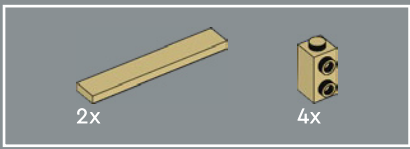

160

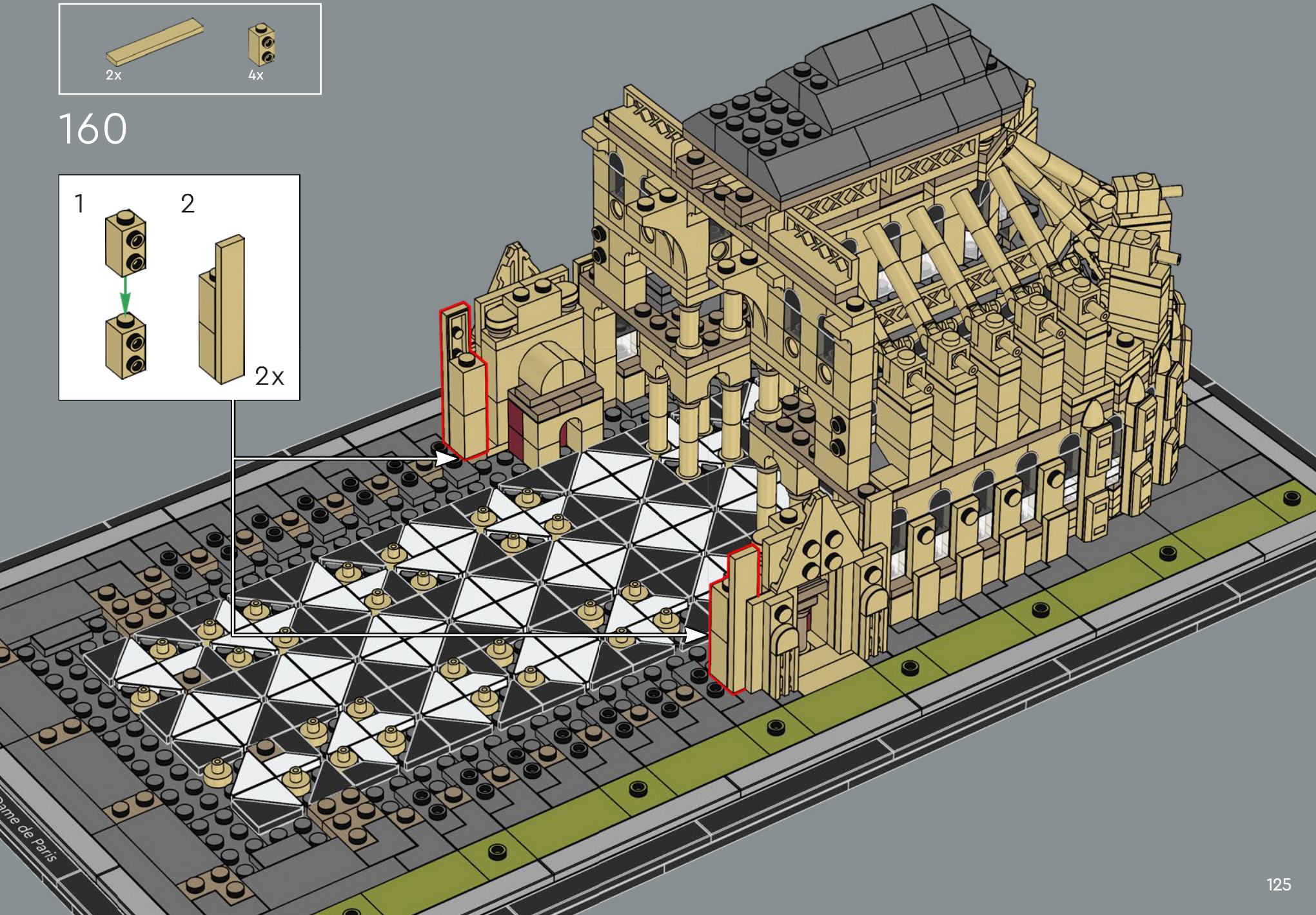
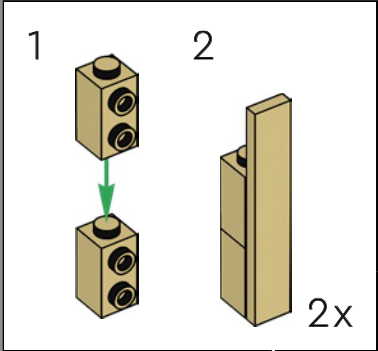

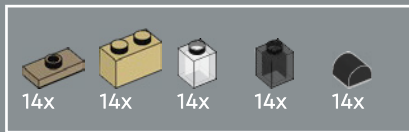

161

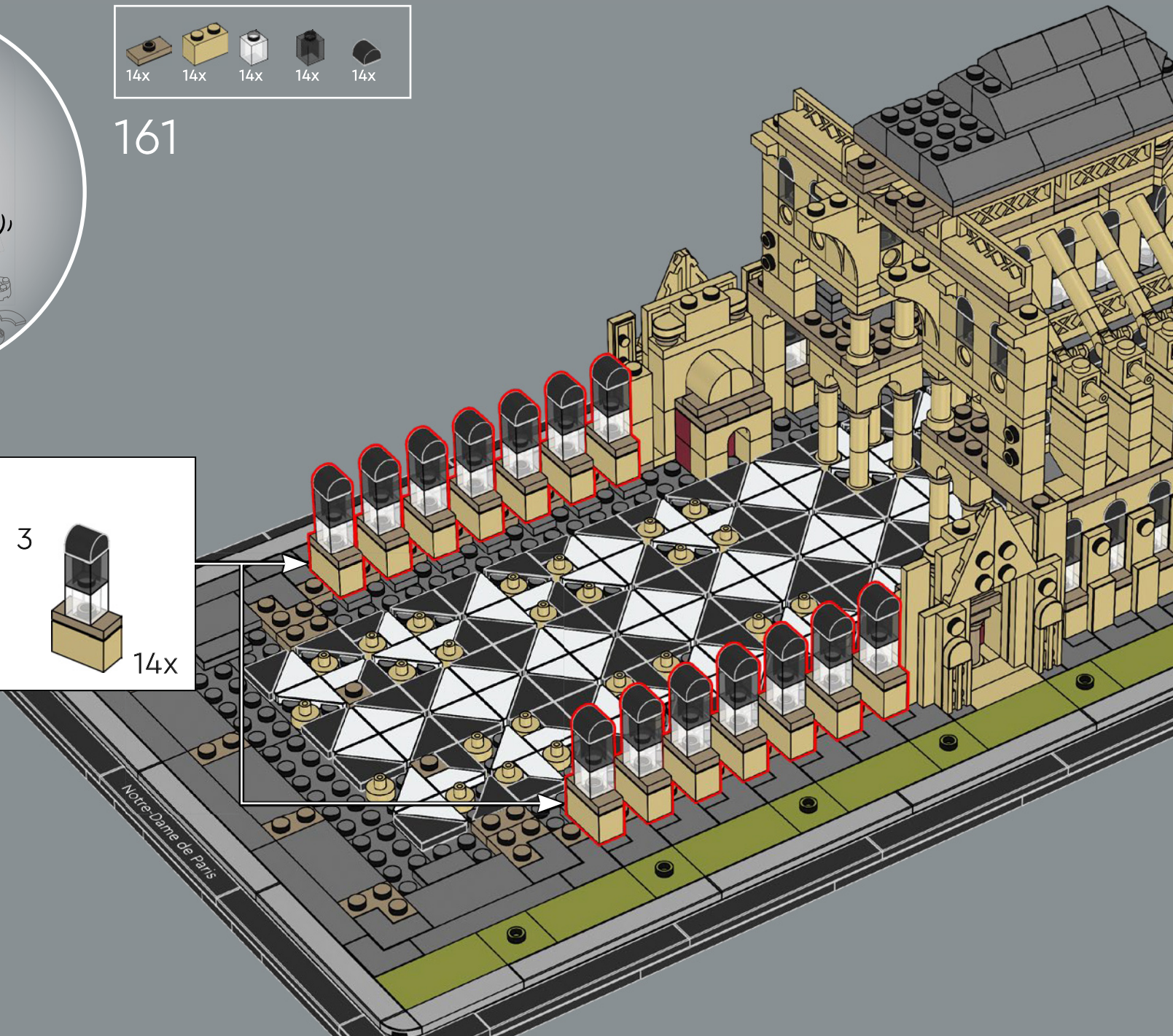
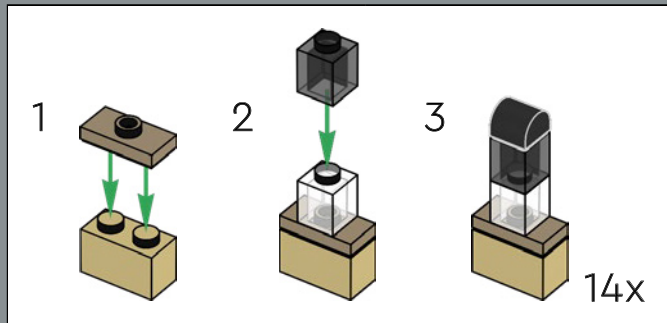

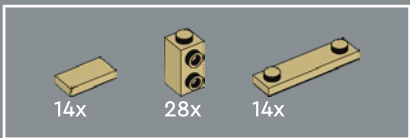

162

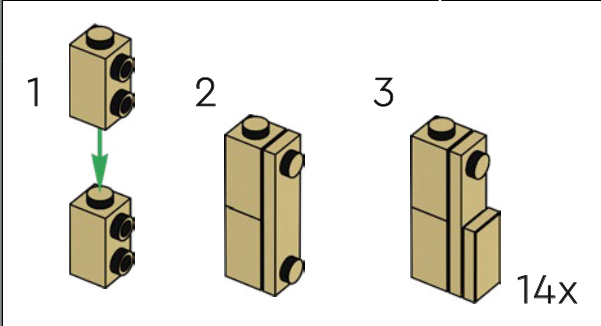
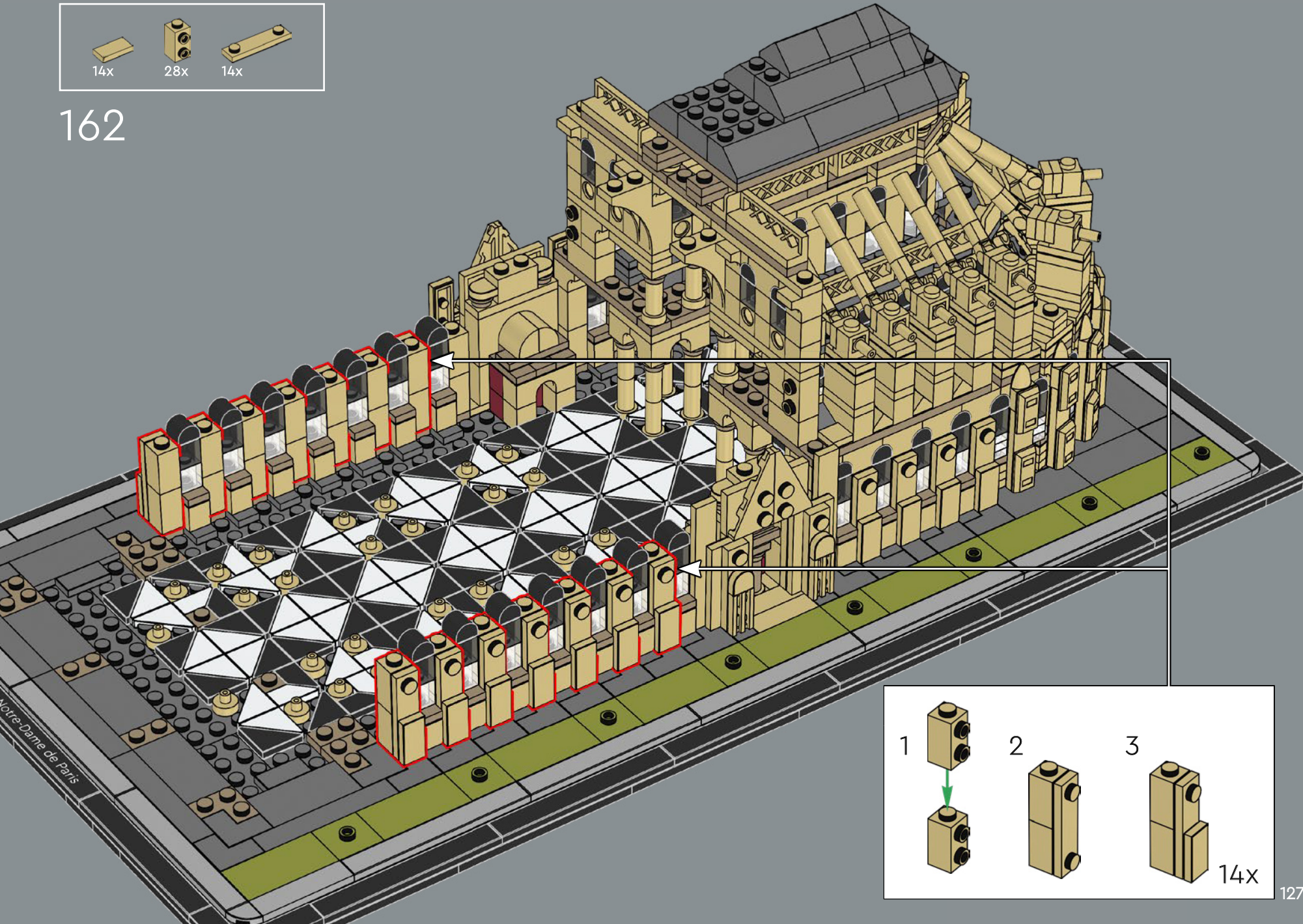



12x



4x

163







164

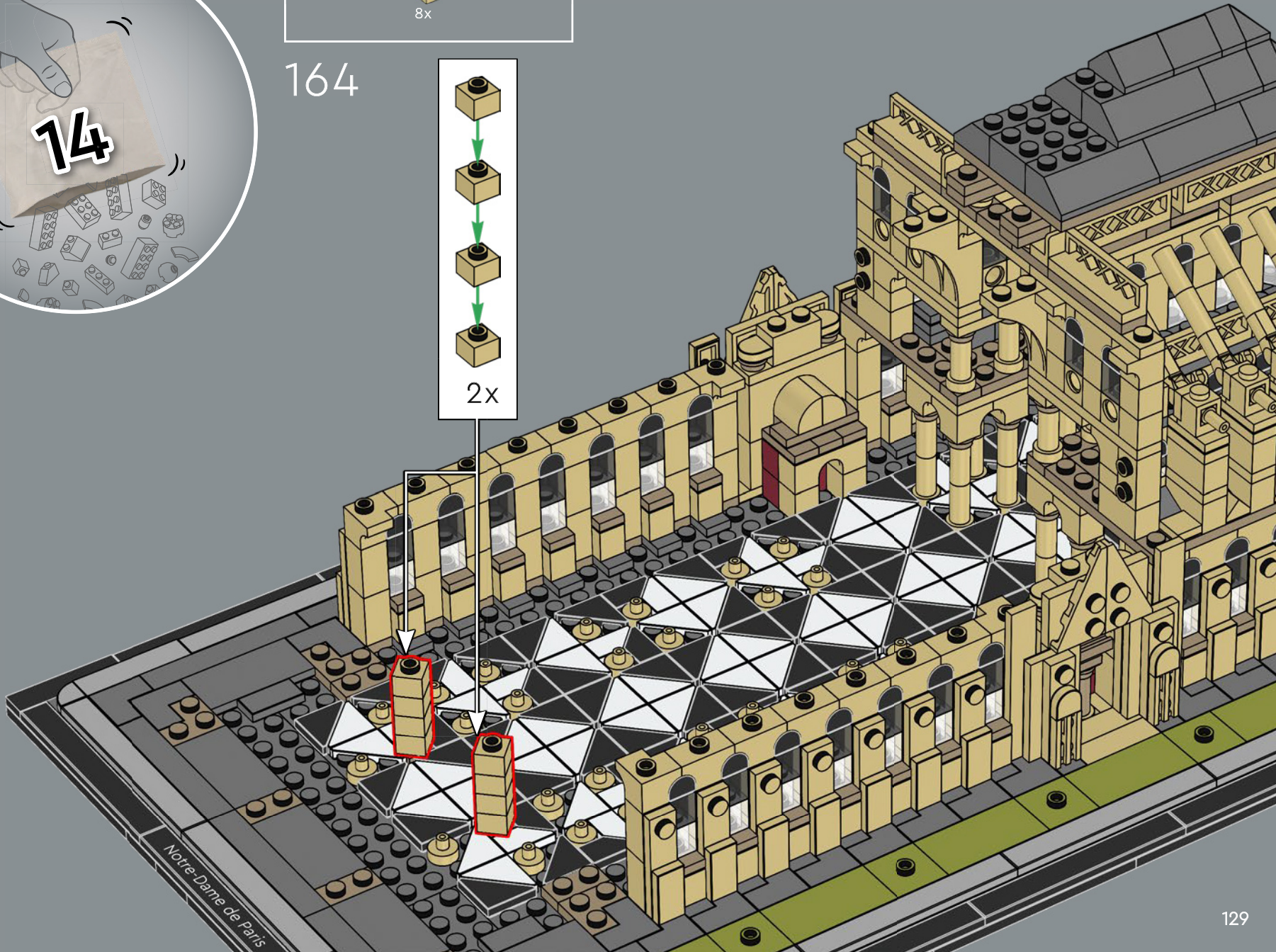
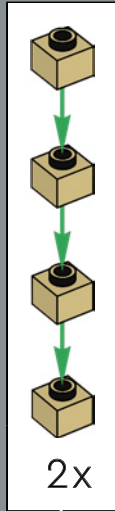



56x

165



28x

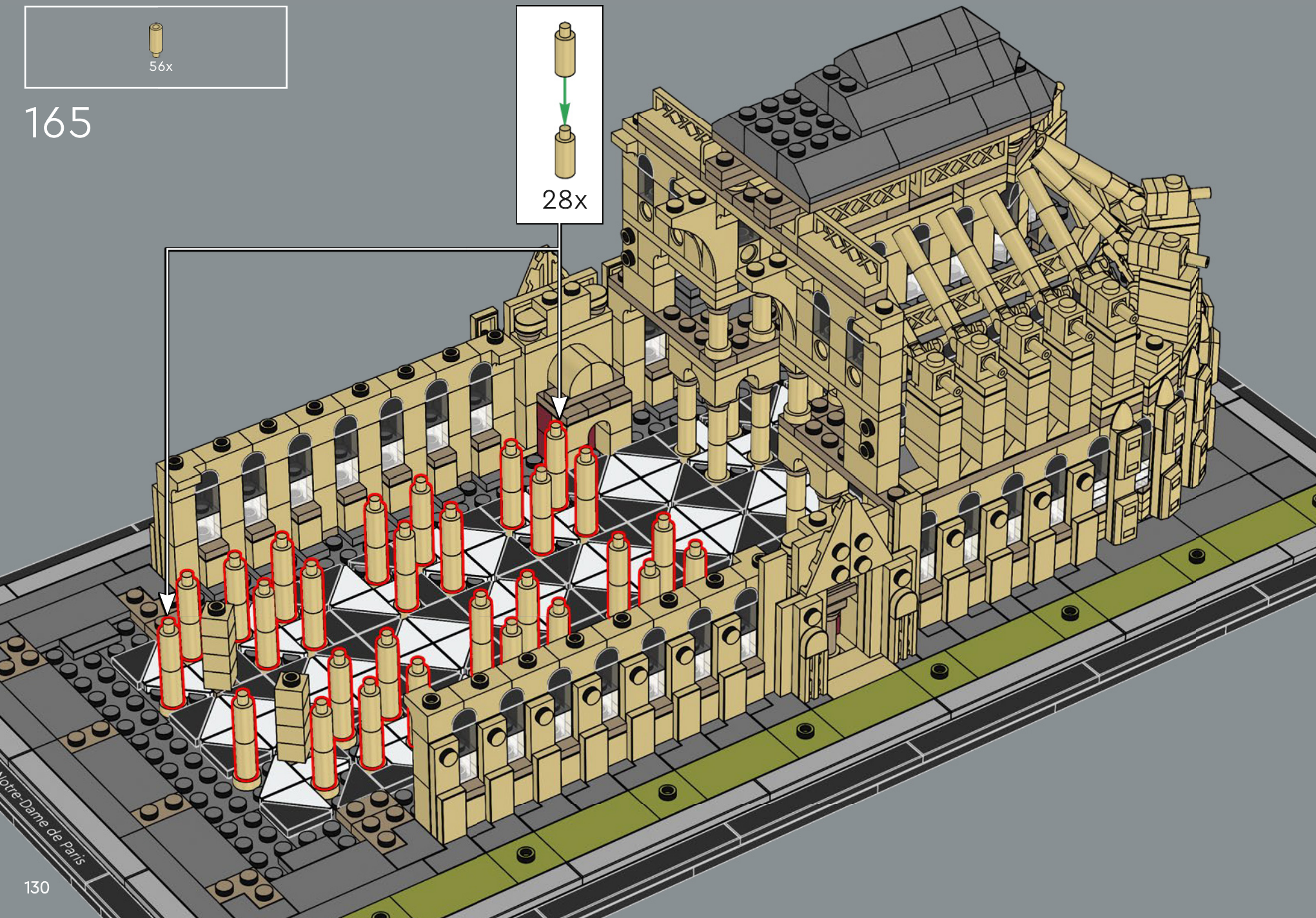

Notre-Dame de Paris

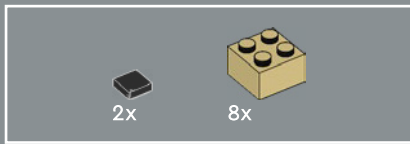

166

1208: Die Arbeiten im Hauptschiff gehen weiter, und die Fundamente für die großen Türme an der Westseite werden gelegt.

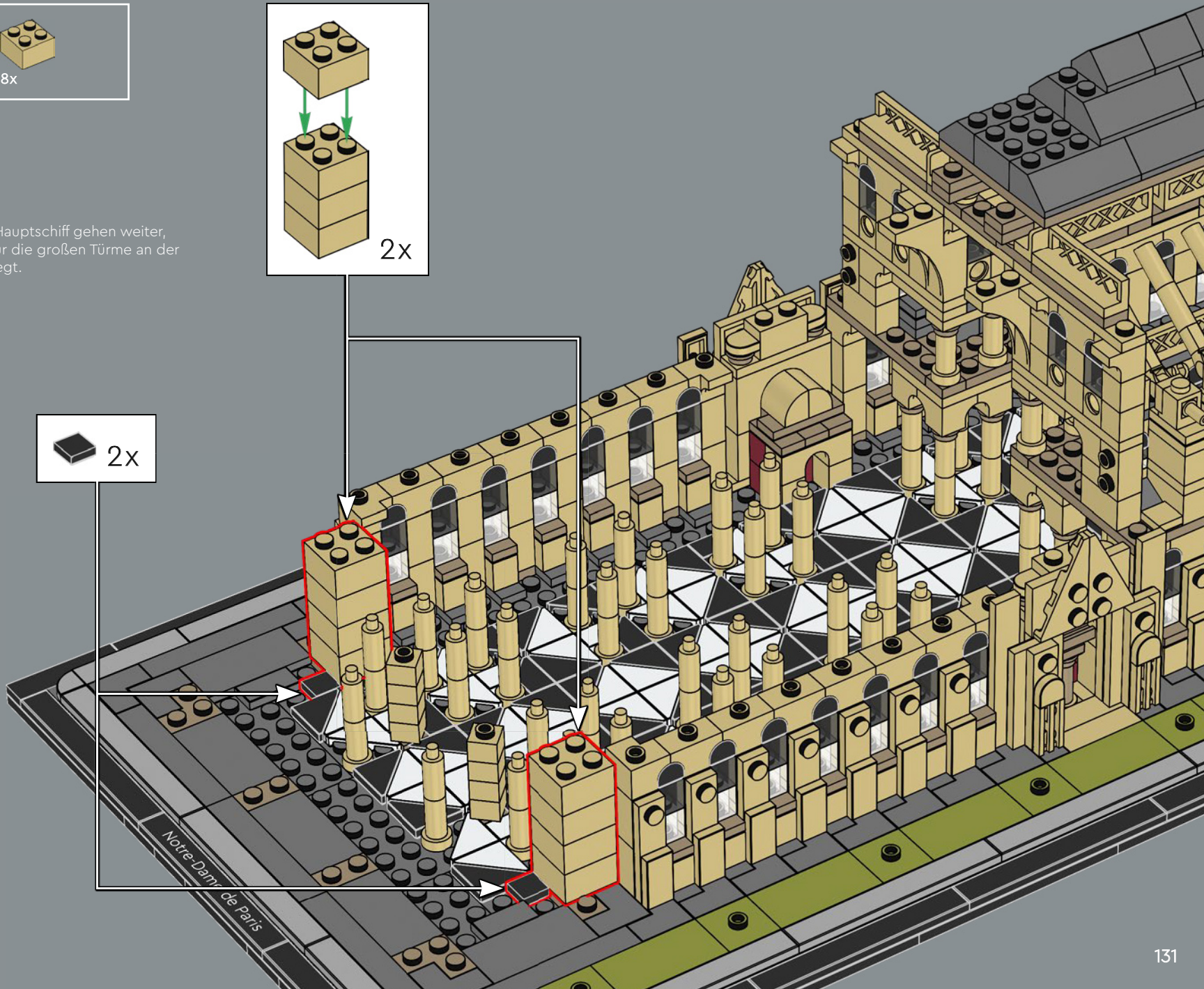
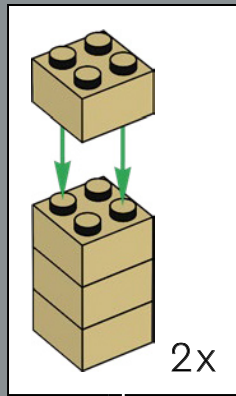

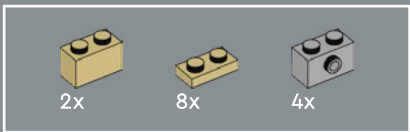

167

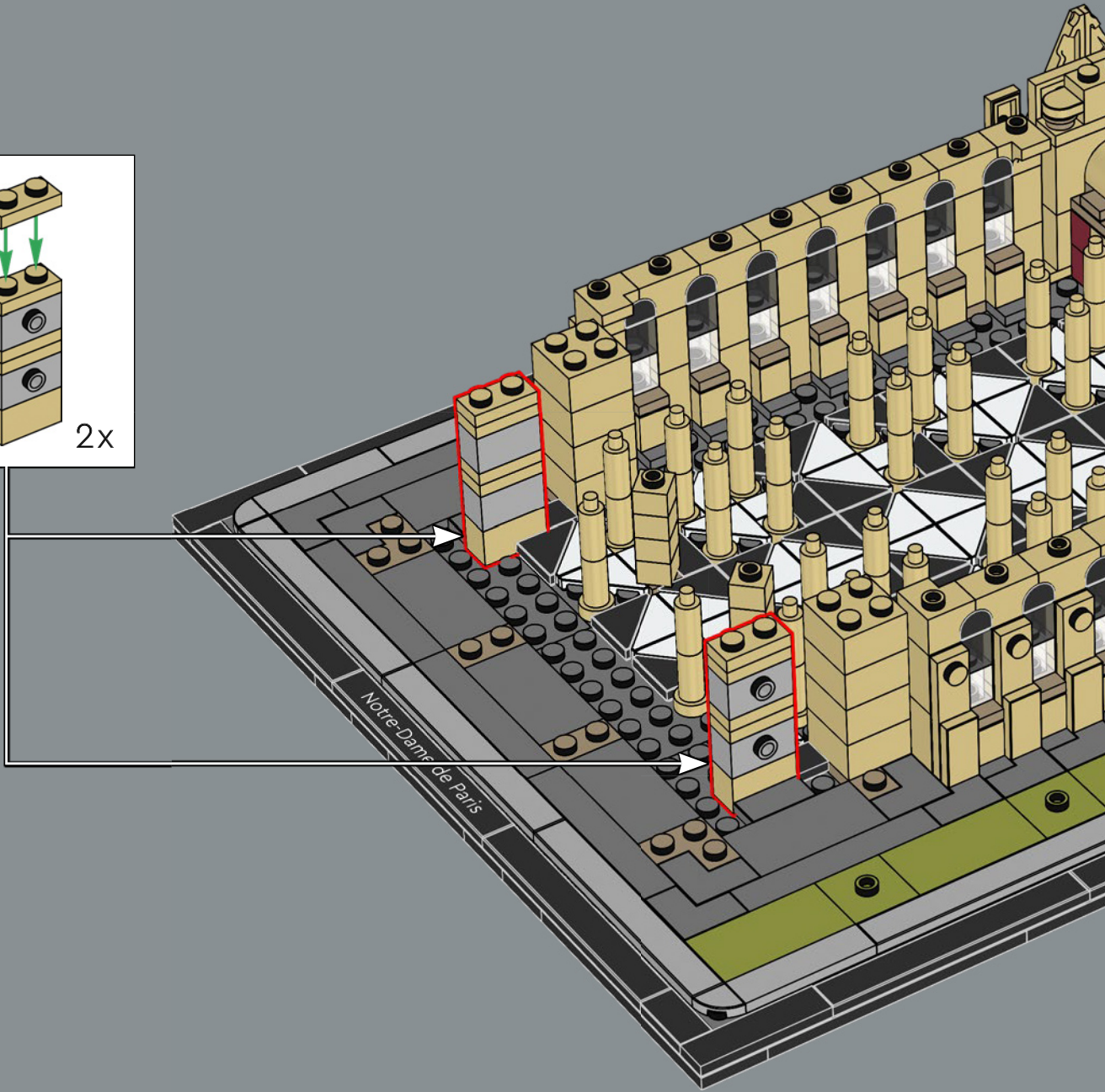
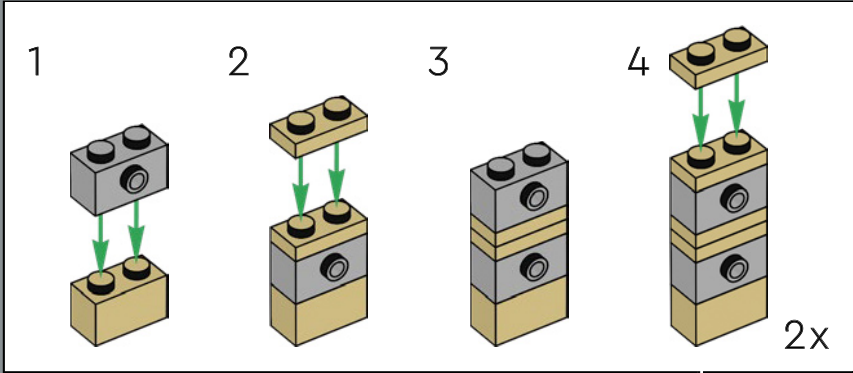

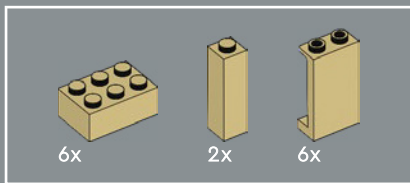

168

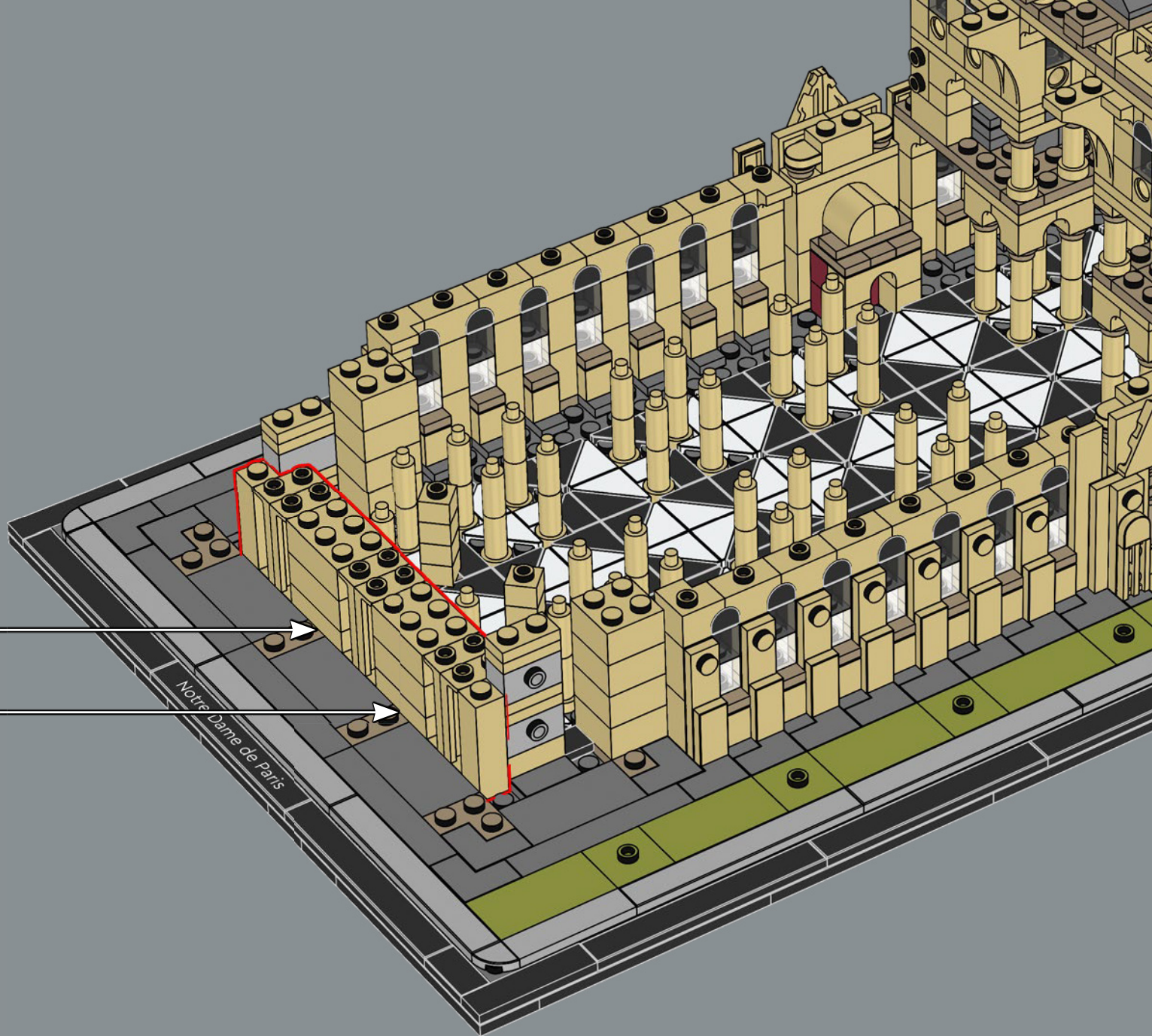
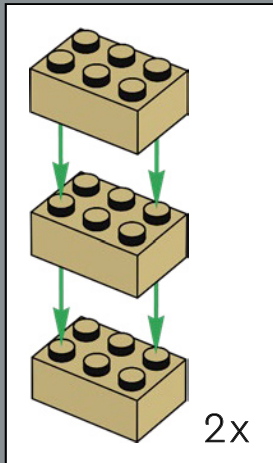

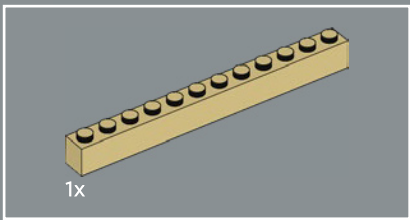

169

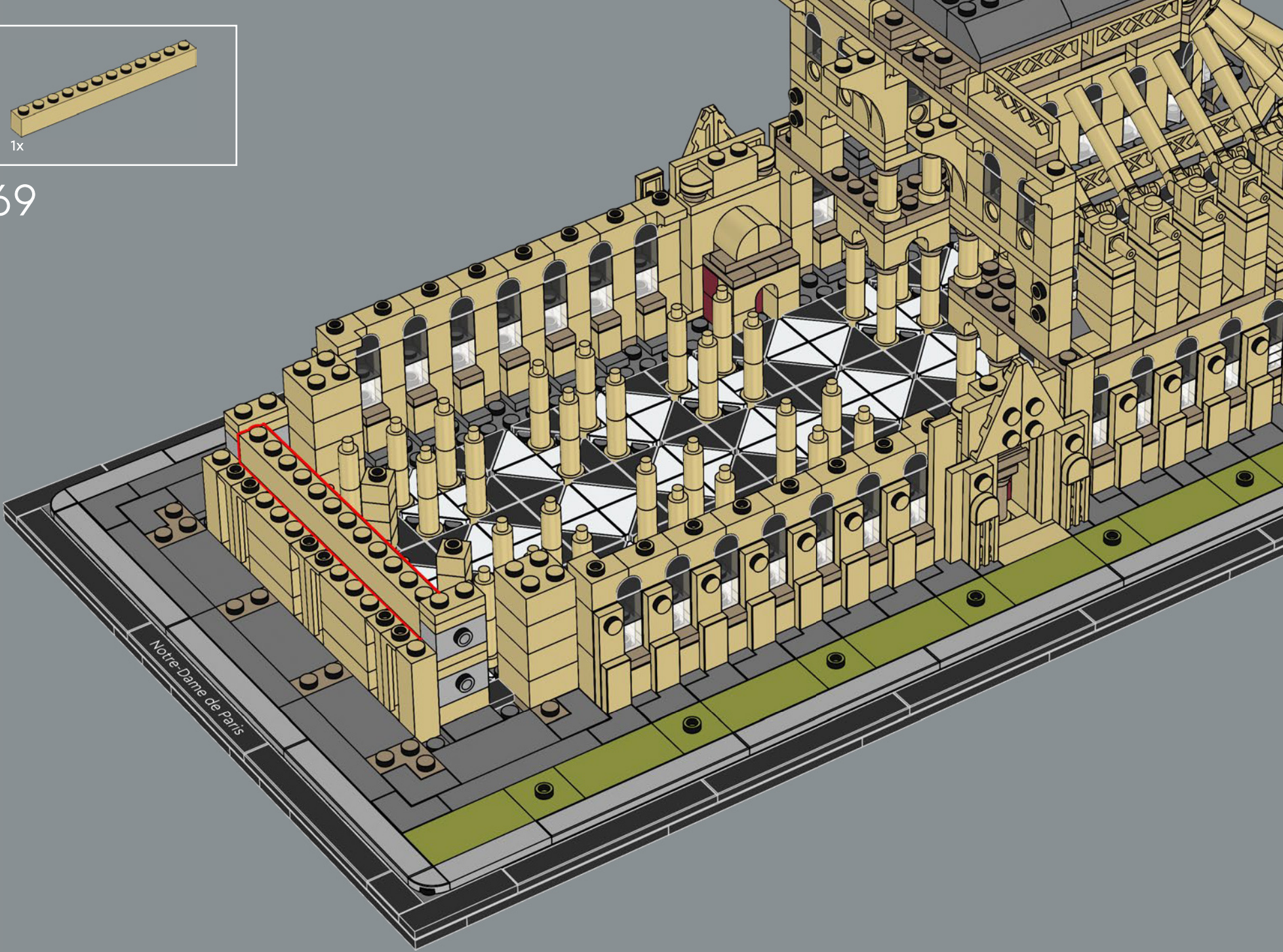

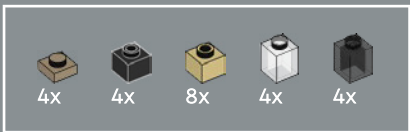

170

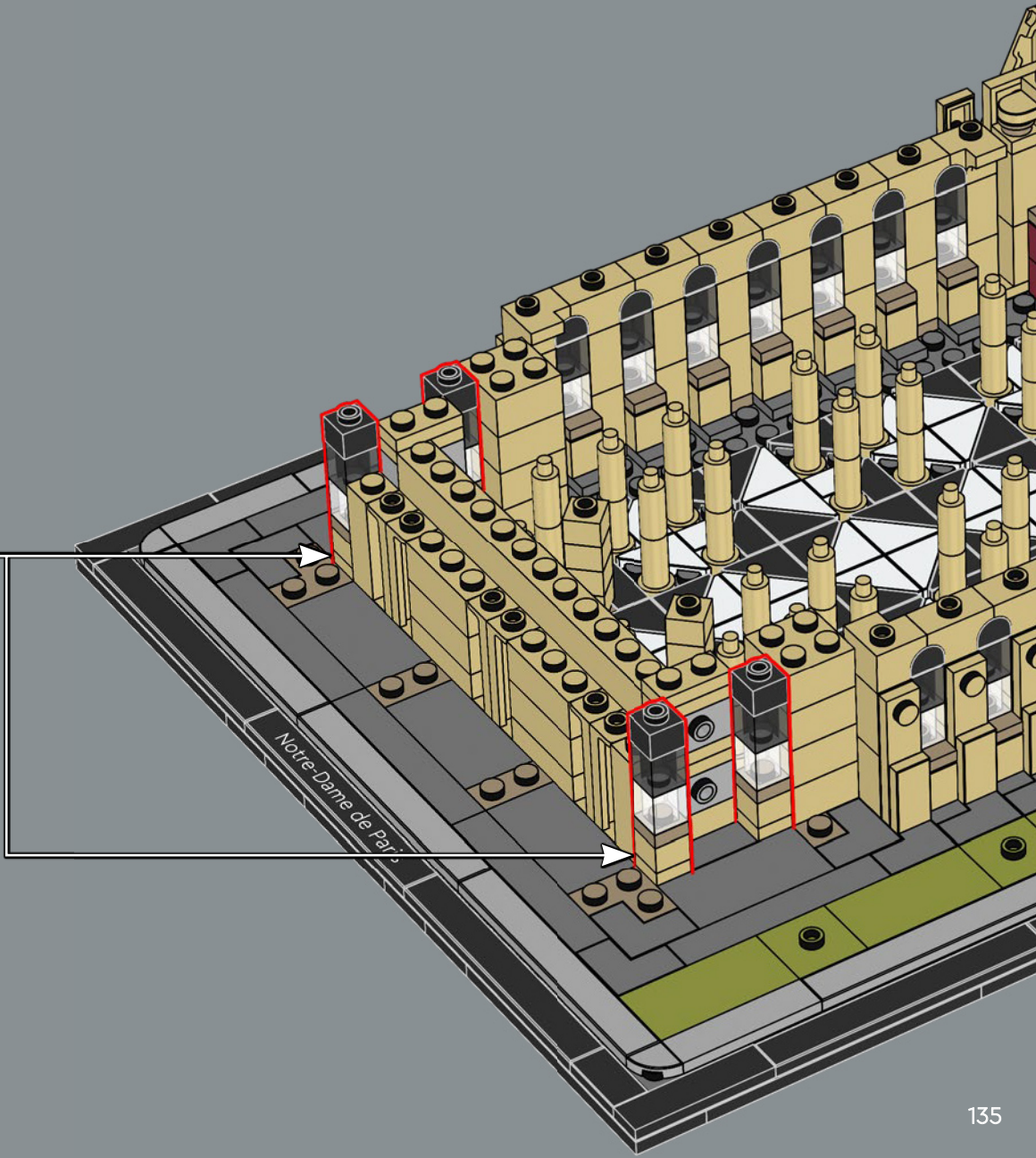
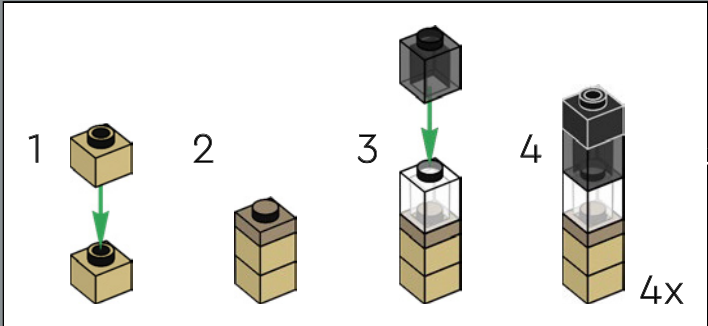

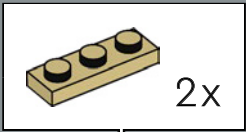
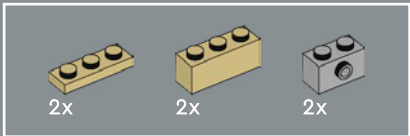

171

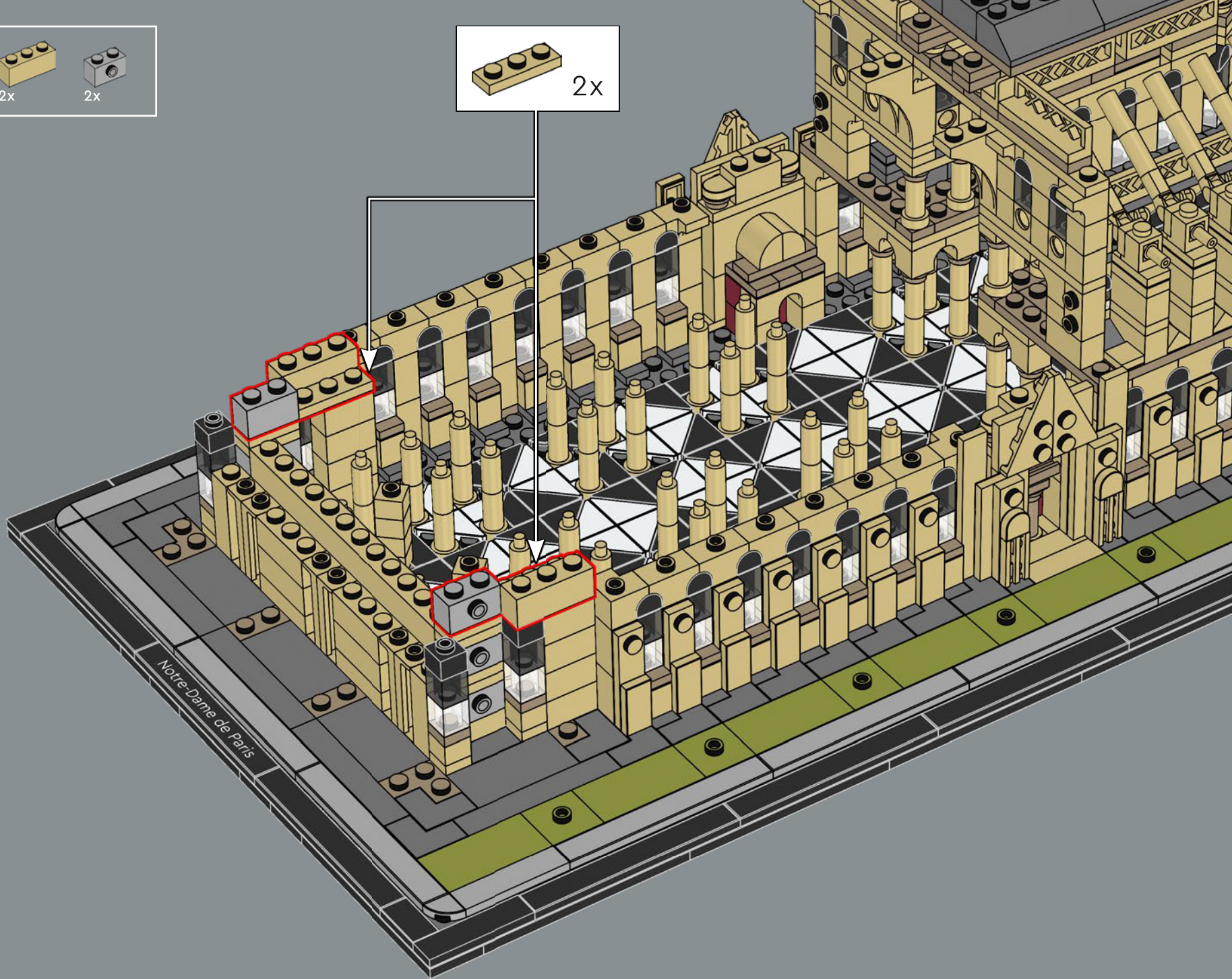



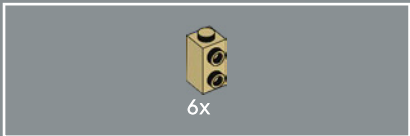

172

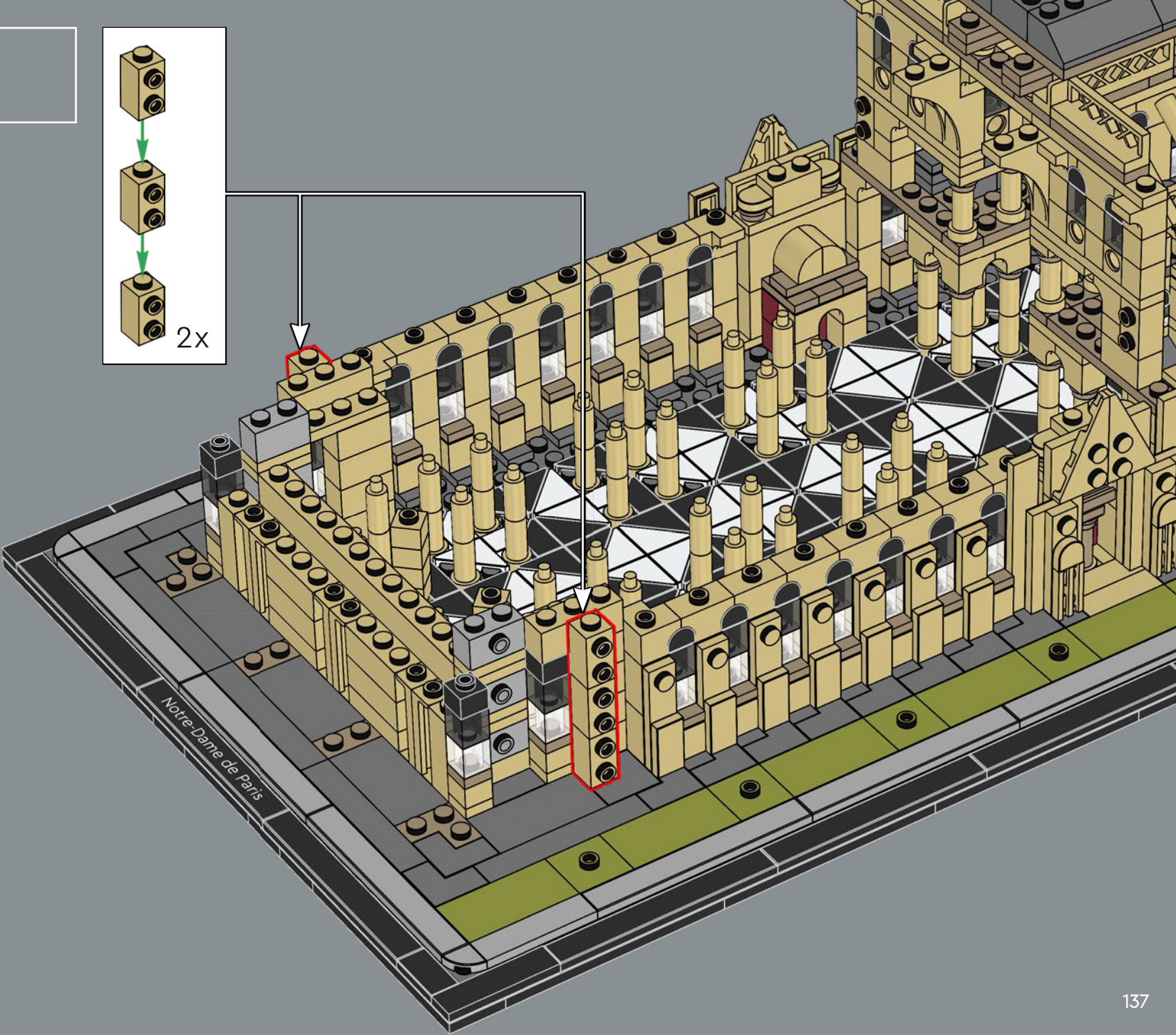
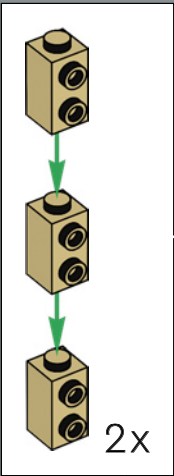

## BAUTECHNIKEN UND BESONDERE MERKMALE

☞ Im Jahr 1208 wurde das Querschiff fertiggestellt. Einzigartige Rosenfenster in unterschiedlichsten Größen und mit verschiedensten Mustern zierten die Fassade. Das ursprüngliche nördliche Rosenfenster hatte einen Durchmesser von 13,5 Metern und war damals das größte seiner Art. Jedes architektonische Merkmal der Kathedrale war nicht nur dekorativ, sondern erfüllte zugleich einen praktischen Zweck. Die drei LEGO® Rosenfenster sind abstrakte Darstellungen der Originalfenster. Sie sind gleich groß und haben dasselbe Muster, damit du sie im Modell beliebig austauschen kannst. Im Jahr 1220 war der Hauptteil der Kathedrale fertig, und es fehlten nur noch die oberen Turmgeschosse.



*Da die typischen Wasserspeier auch Regenwasser ableiten, schützen sie die Kathedrale vor Schäden durch heftige Niederschläge. Diese Funktion ist in deinem Modell nachgebildet.*



173

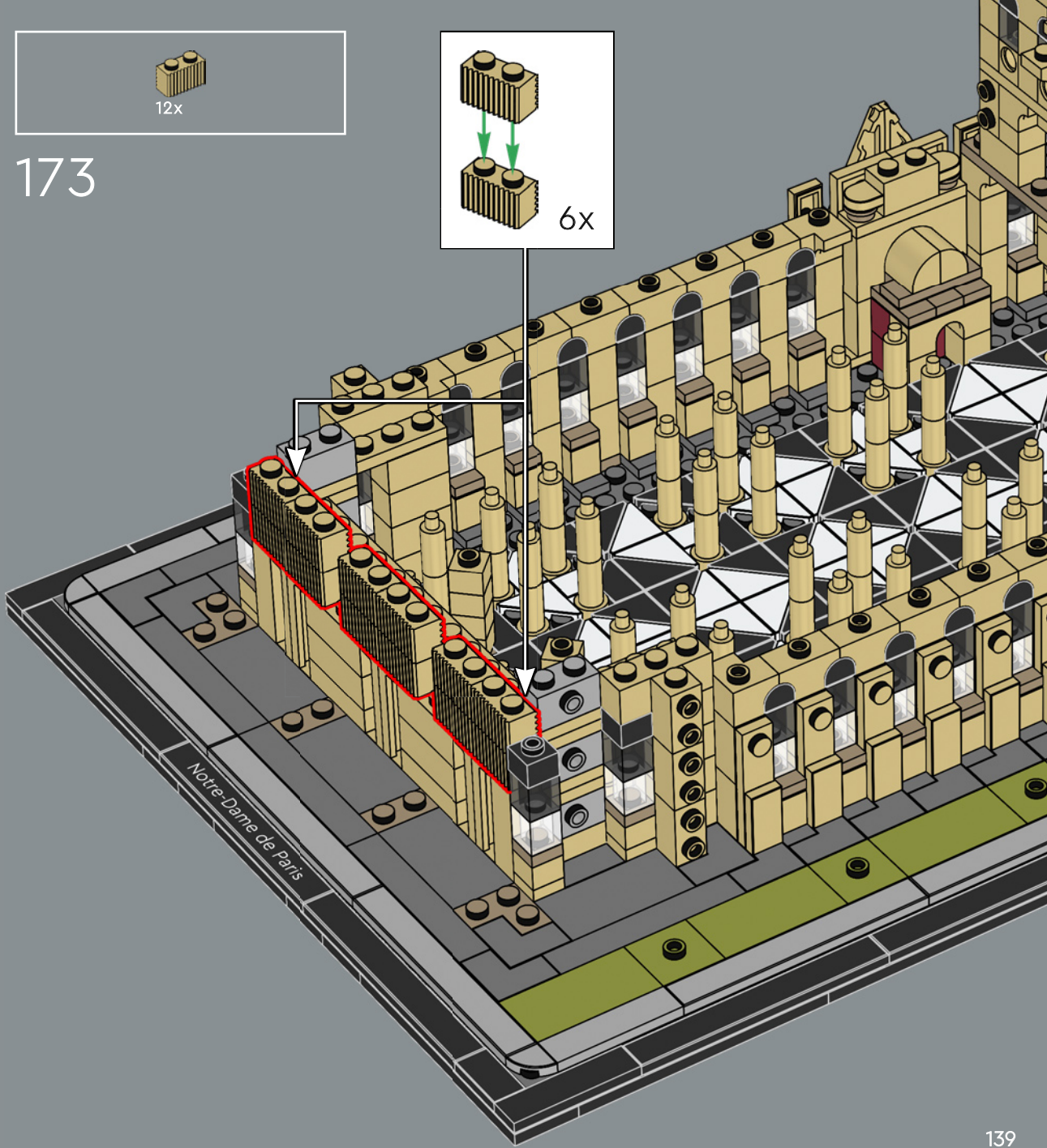
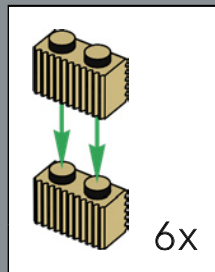



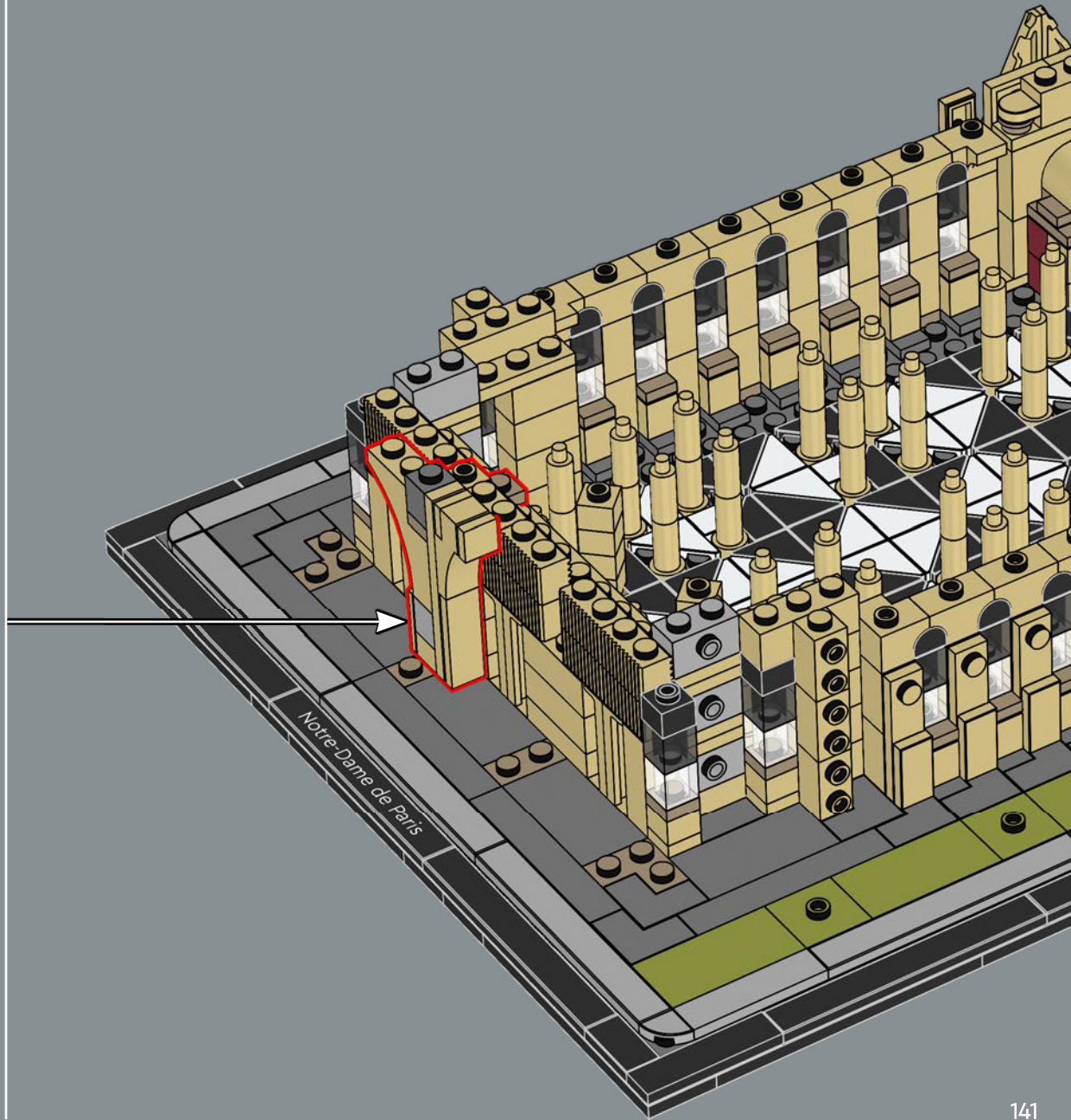
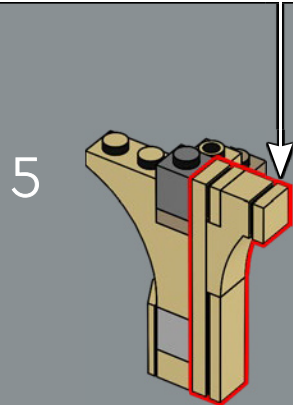
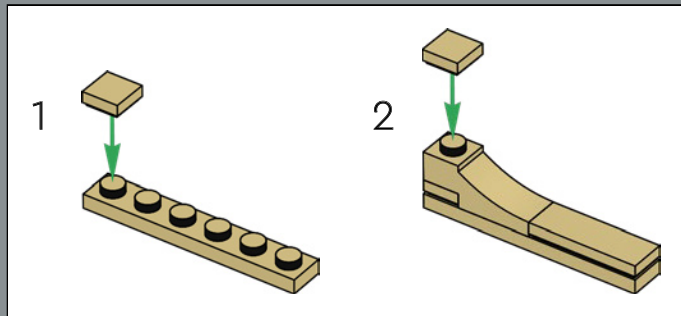



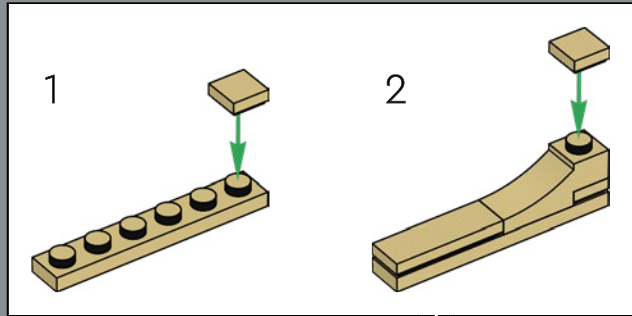

5

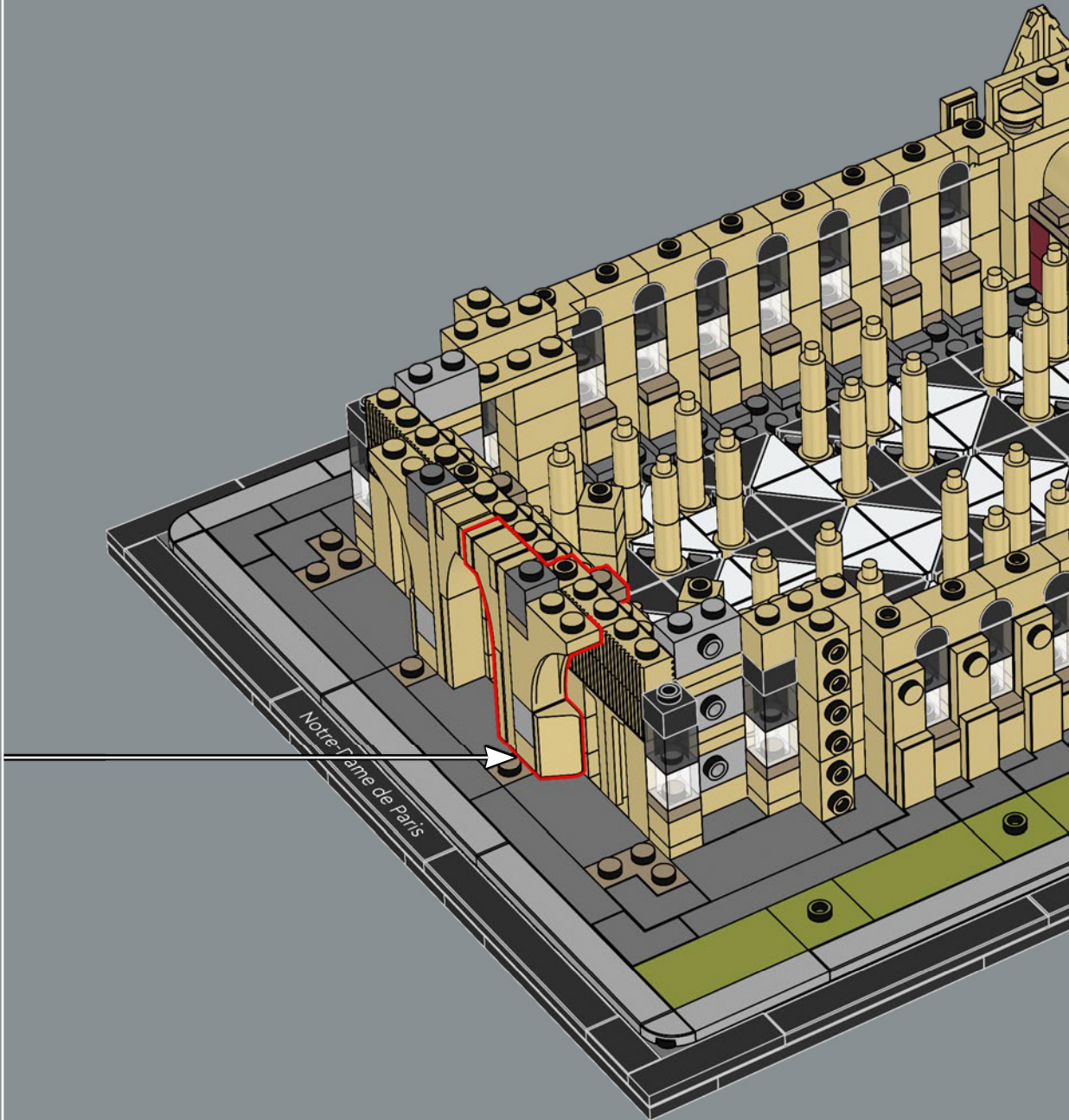
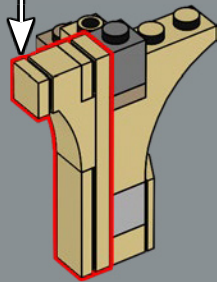

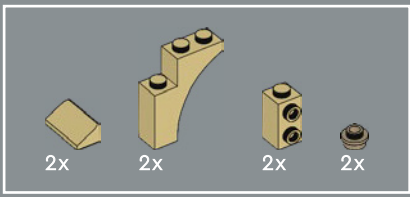

176

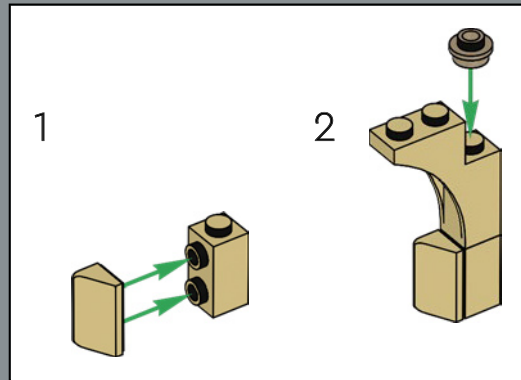
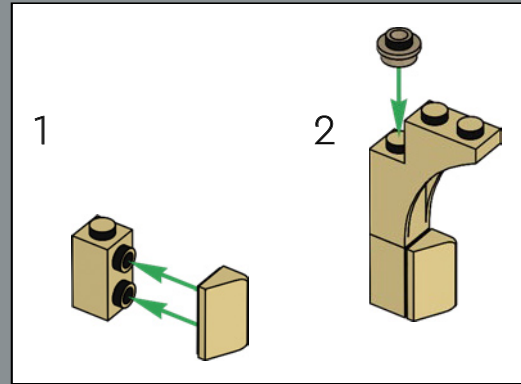



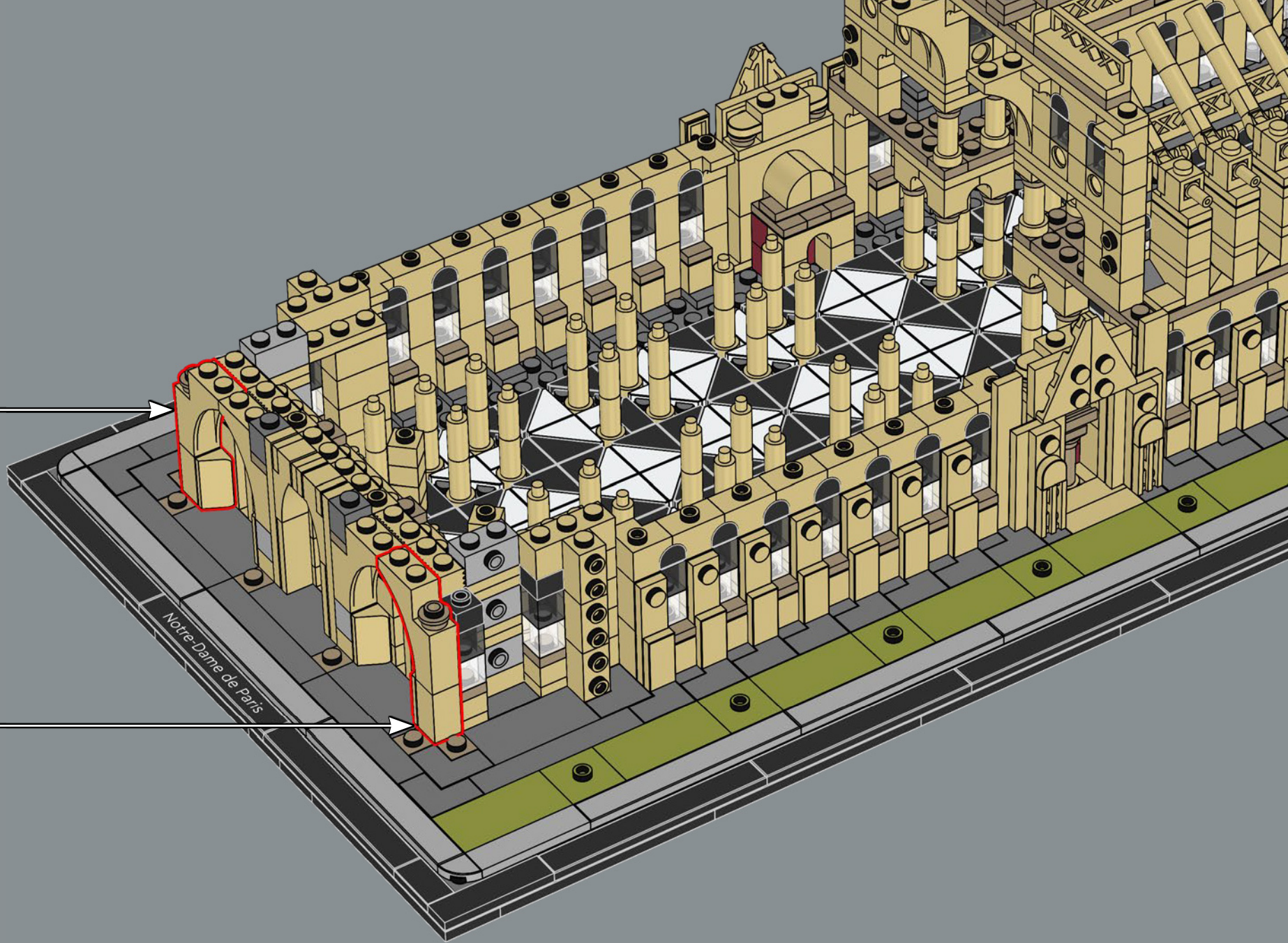

Notre-Dame de Paris

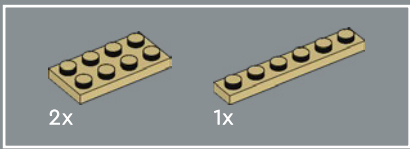

177



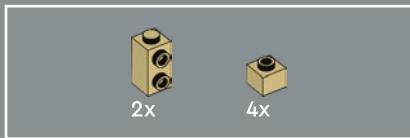

178

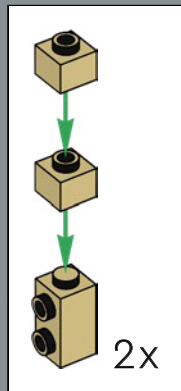

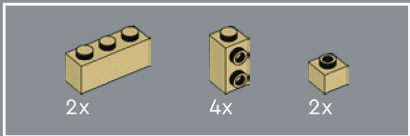

179

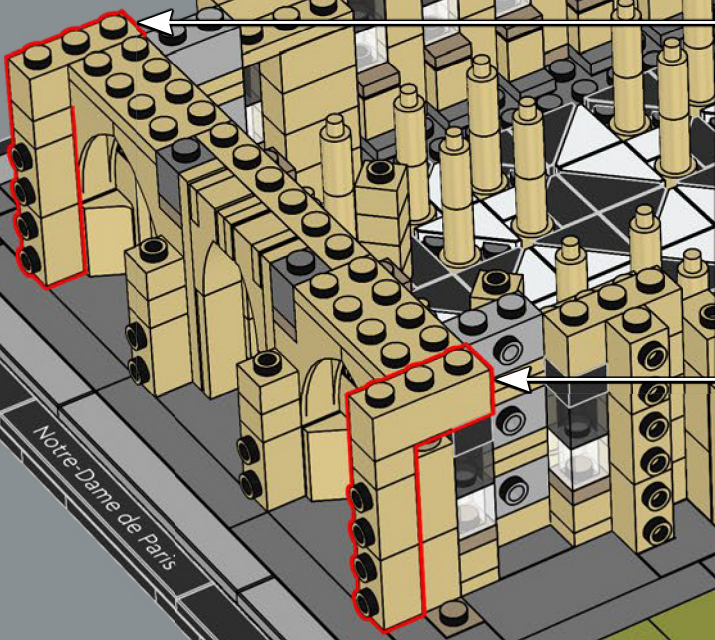
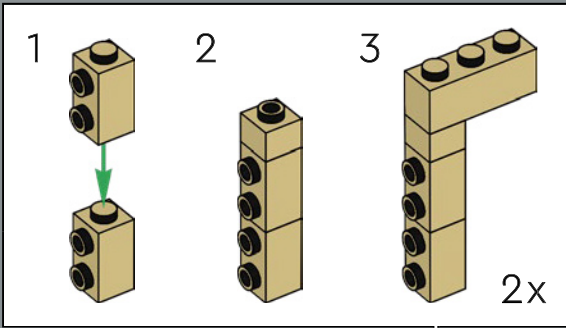

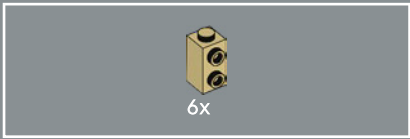

180

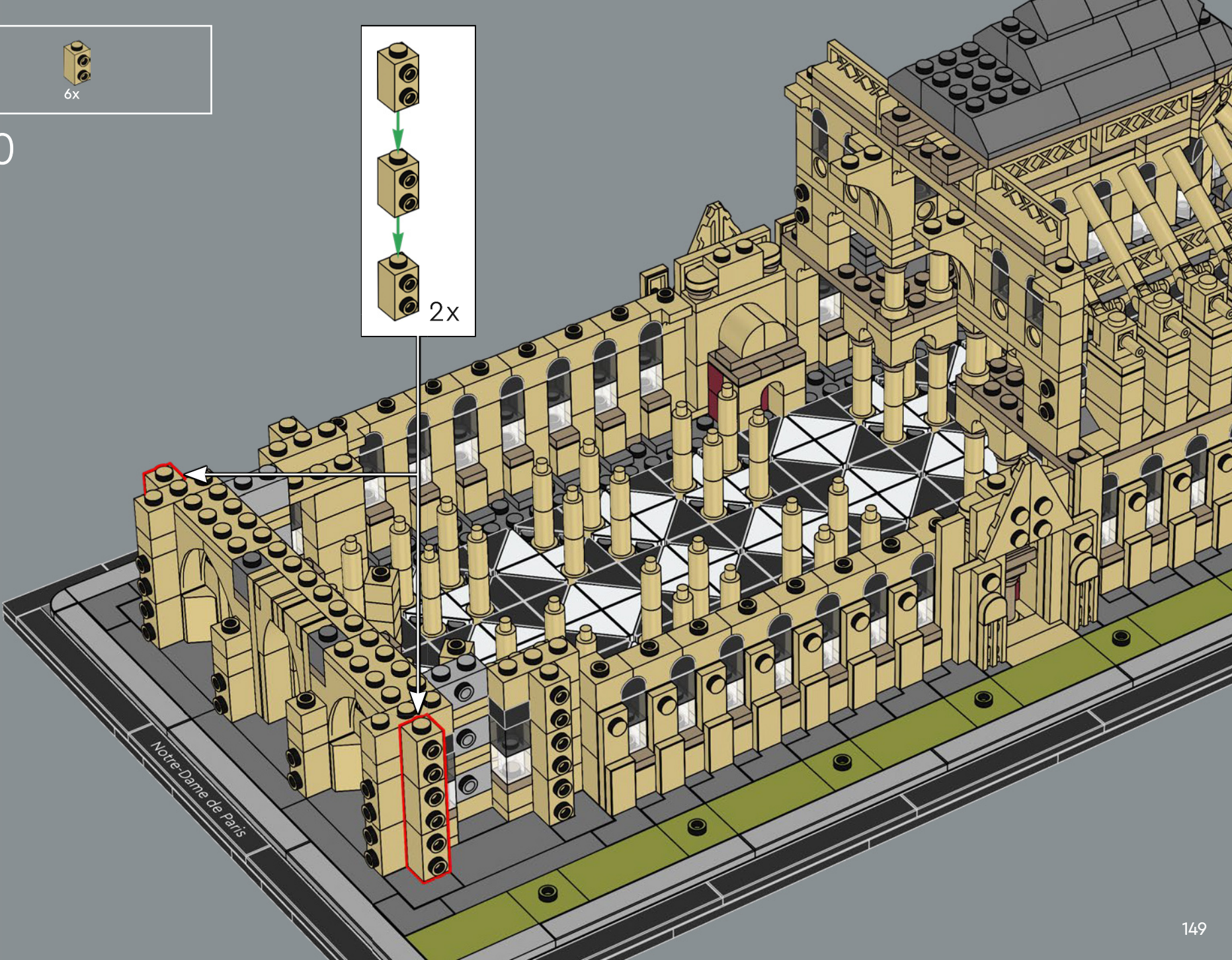
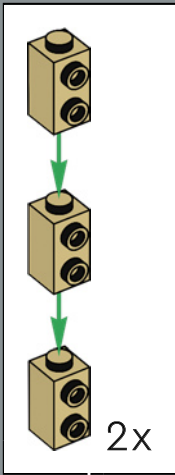

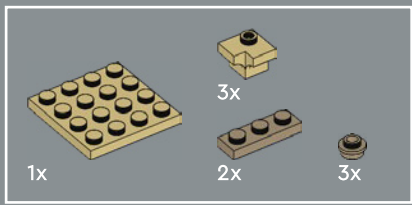

181

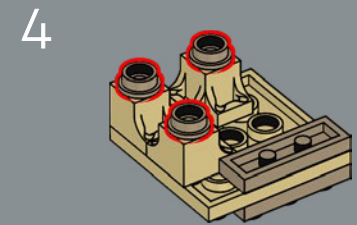
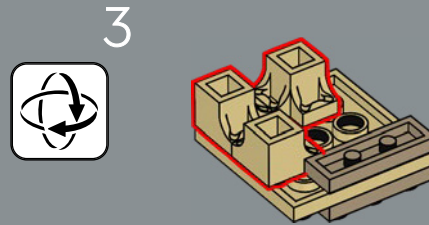
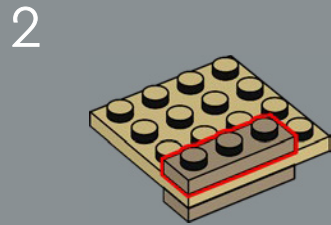
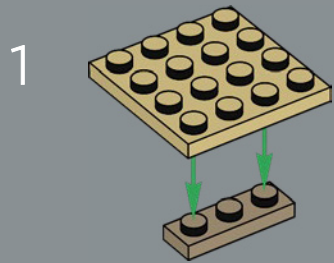



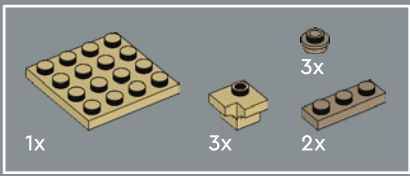

182

1

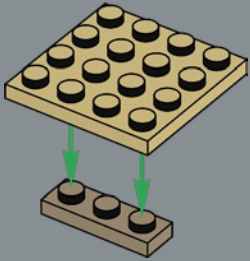

2

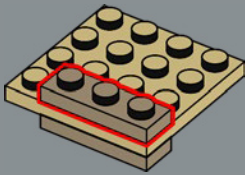

3

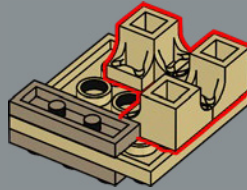

4

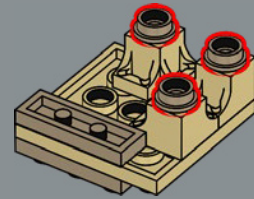





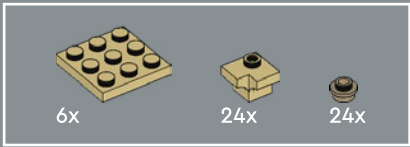

183

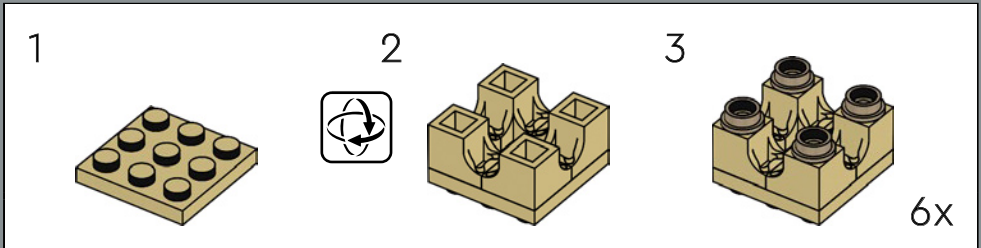

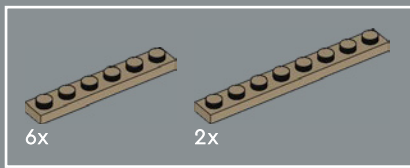



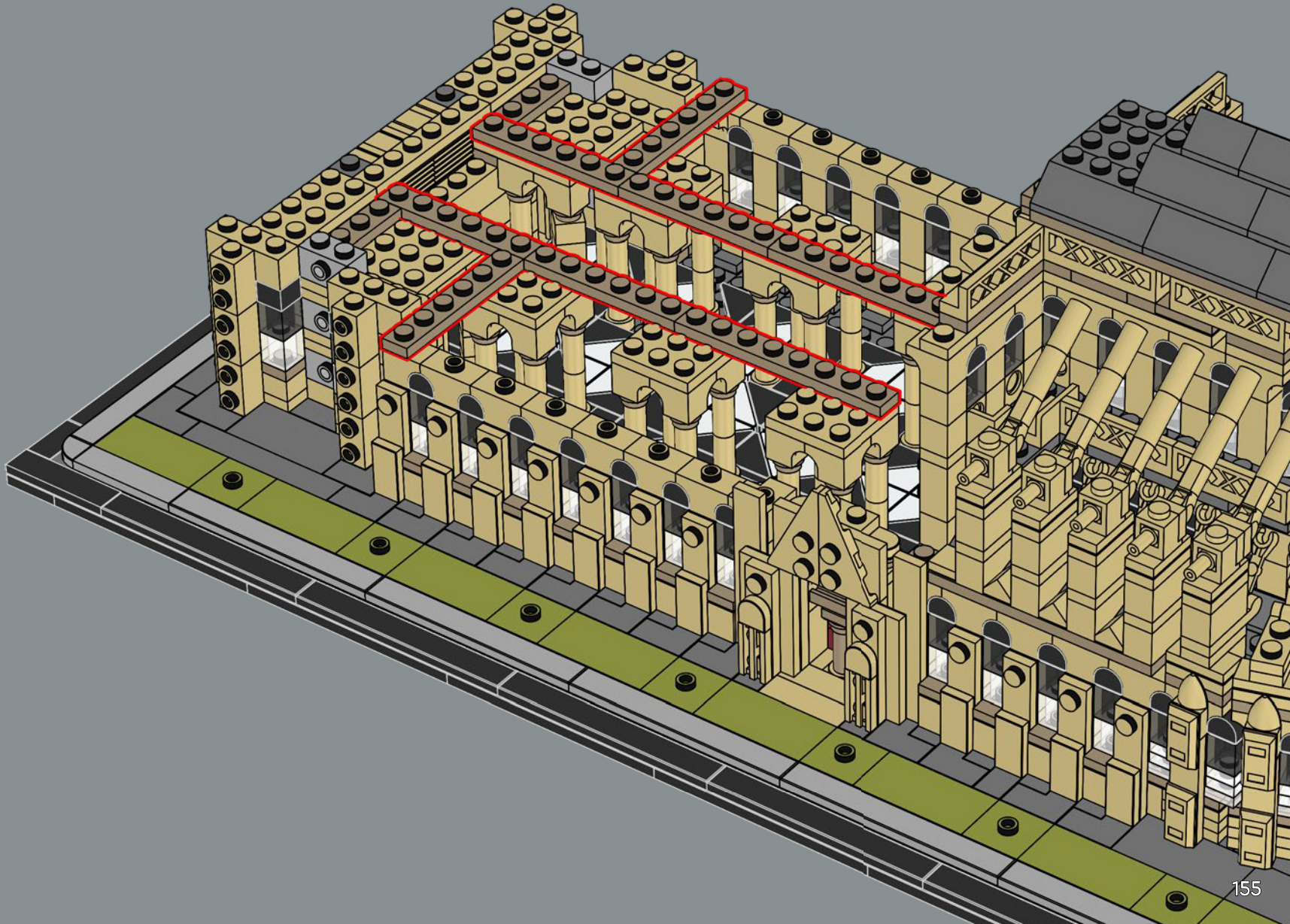

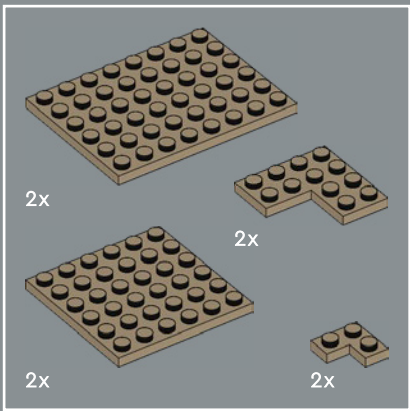
184



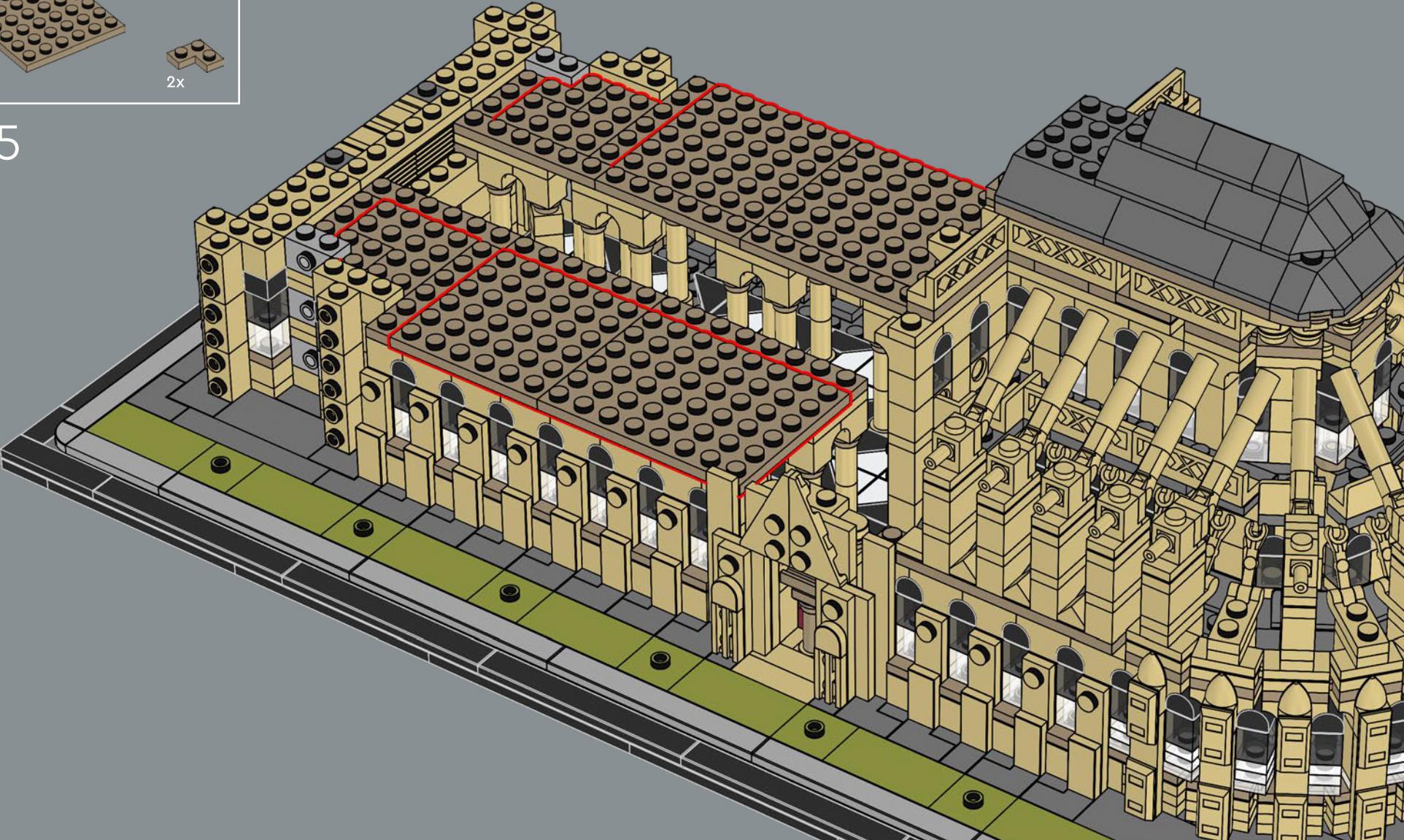

185



		
2x	2x	12x

186



*Notre-Dame de Paris*

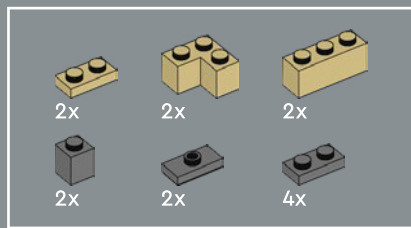

187

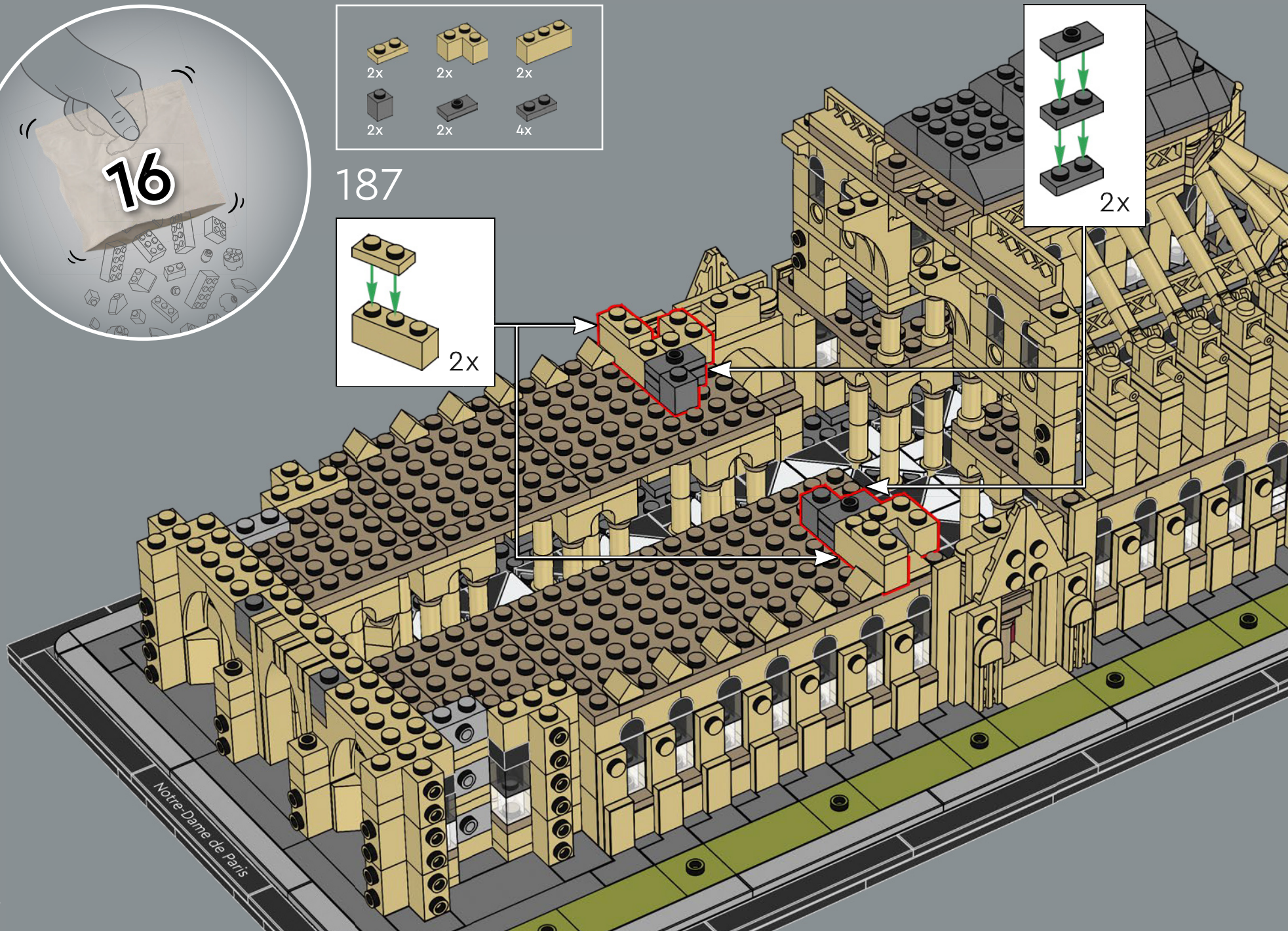
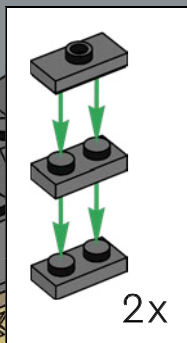
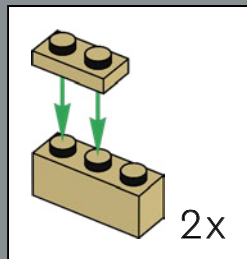

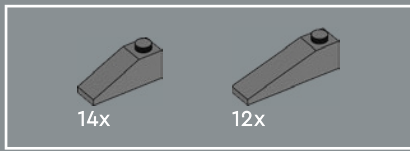

188



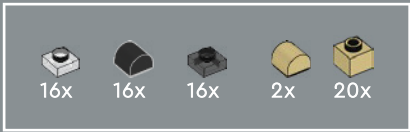

189

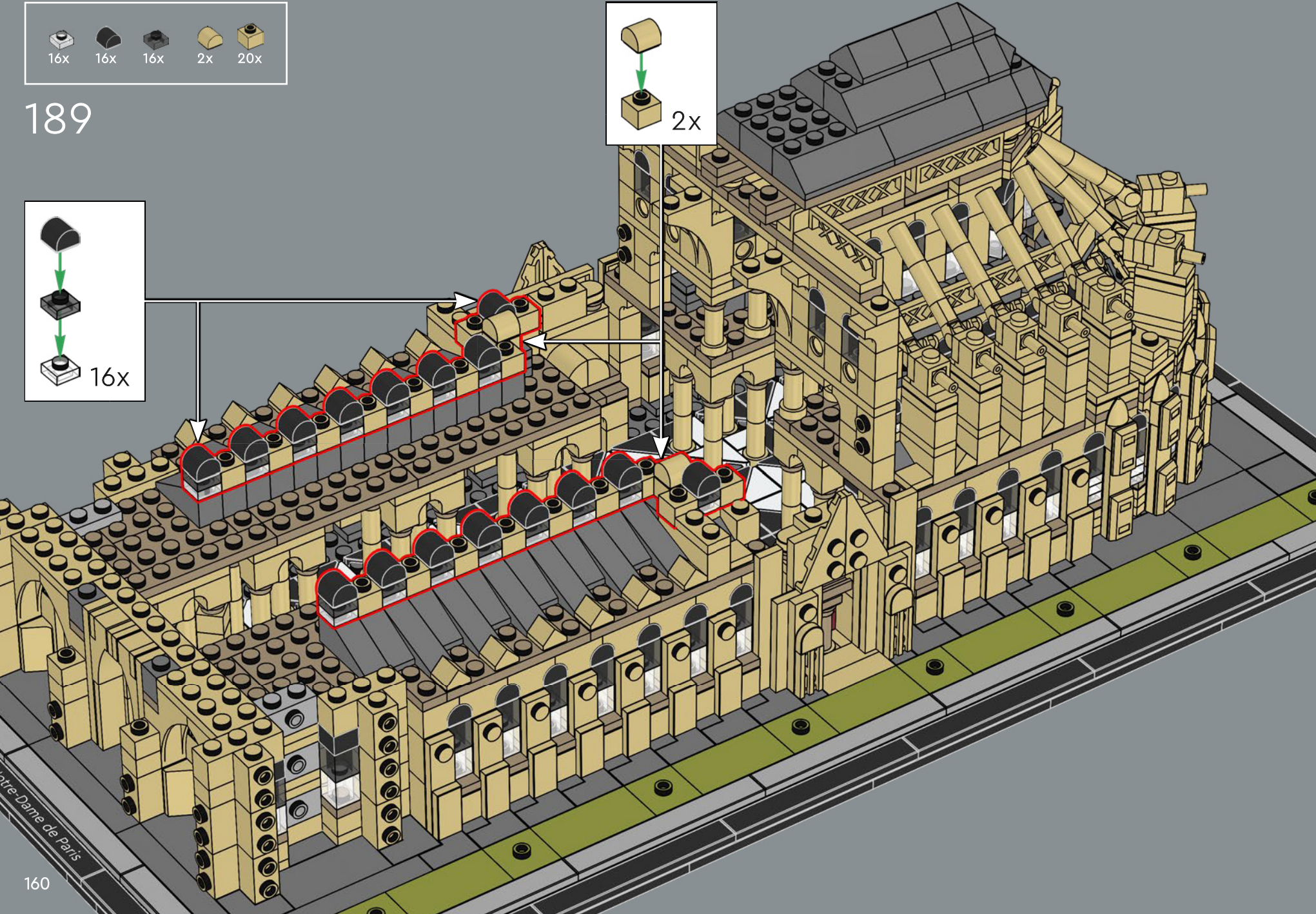
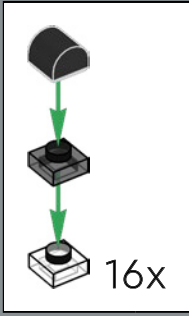
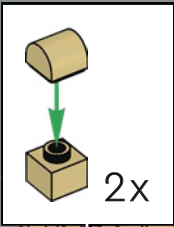



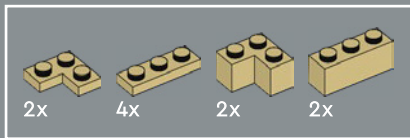

190

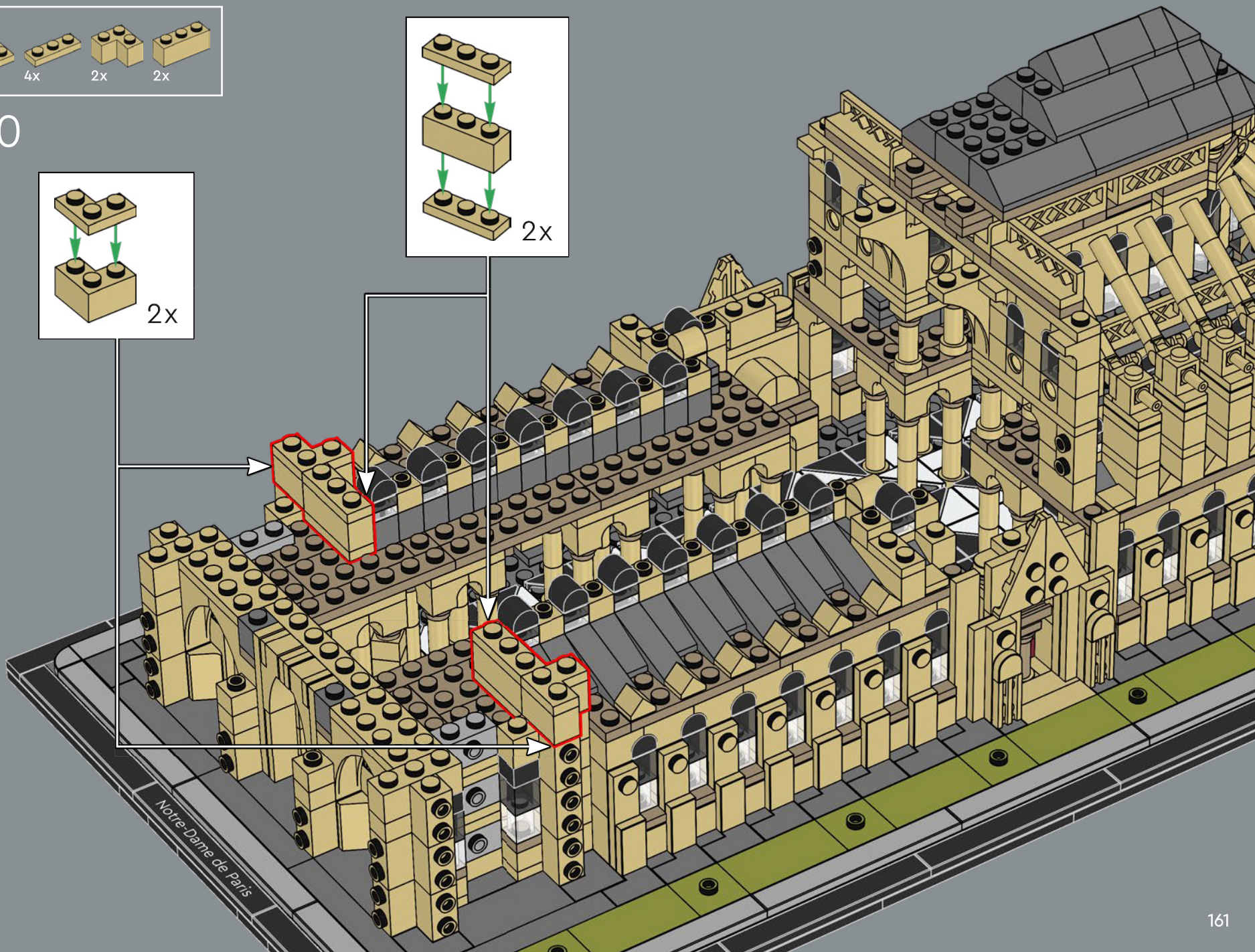
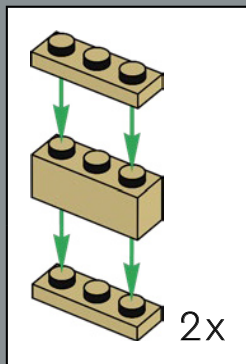
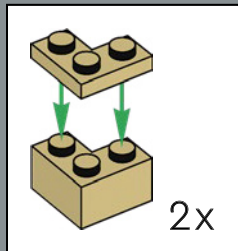



6x

191

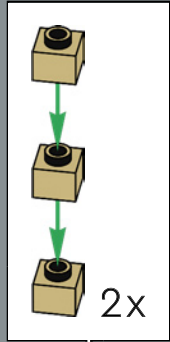

Notre-Dame de Paris

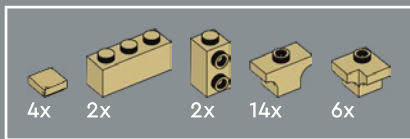

192

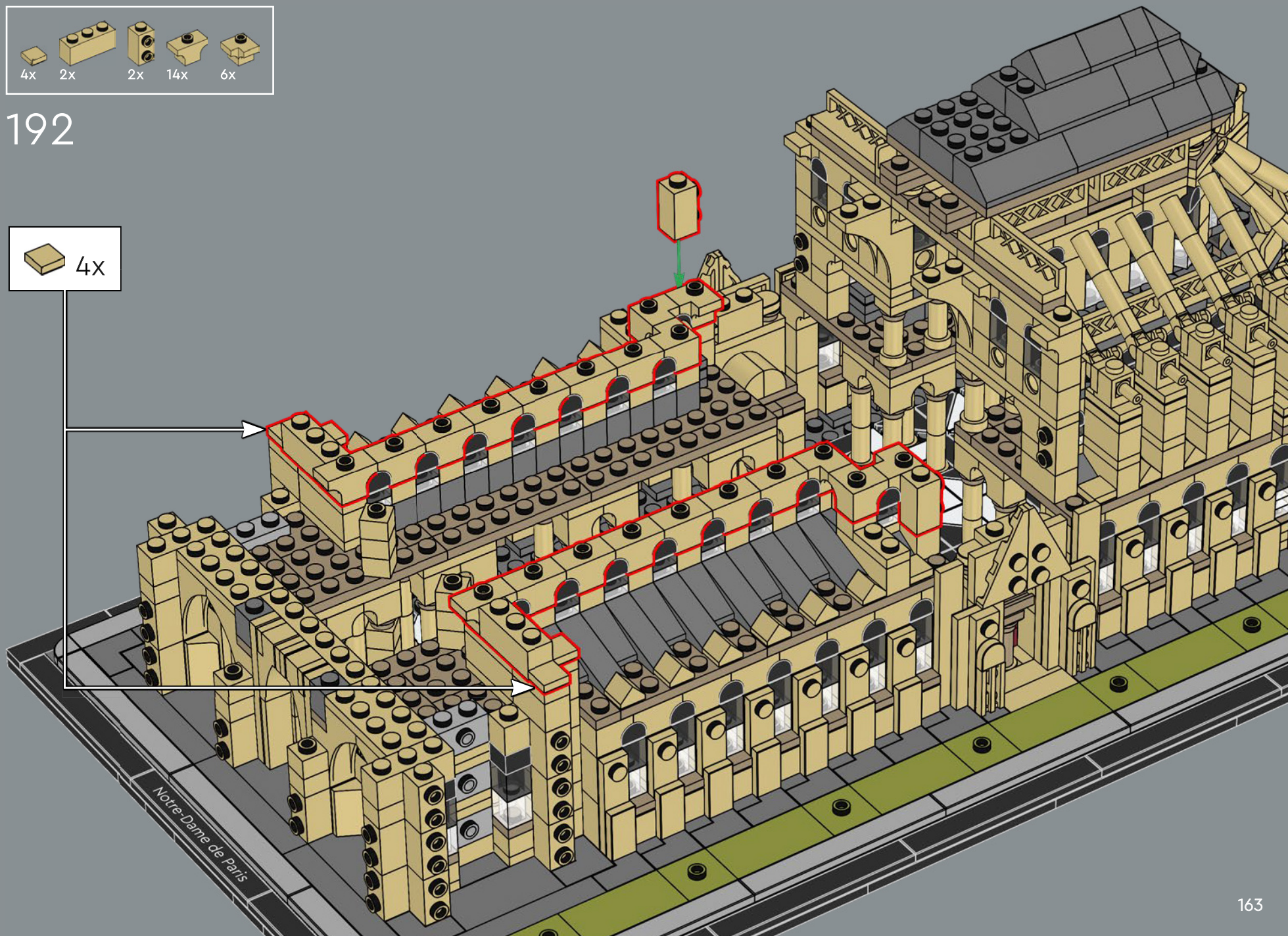

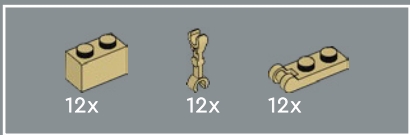

193

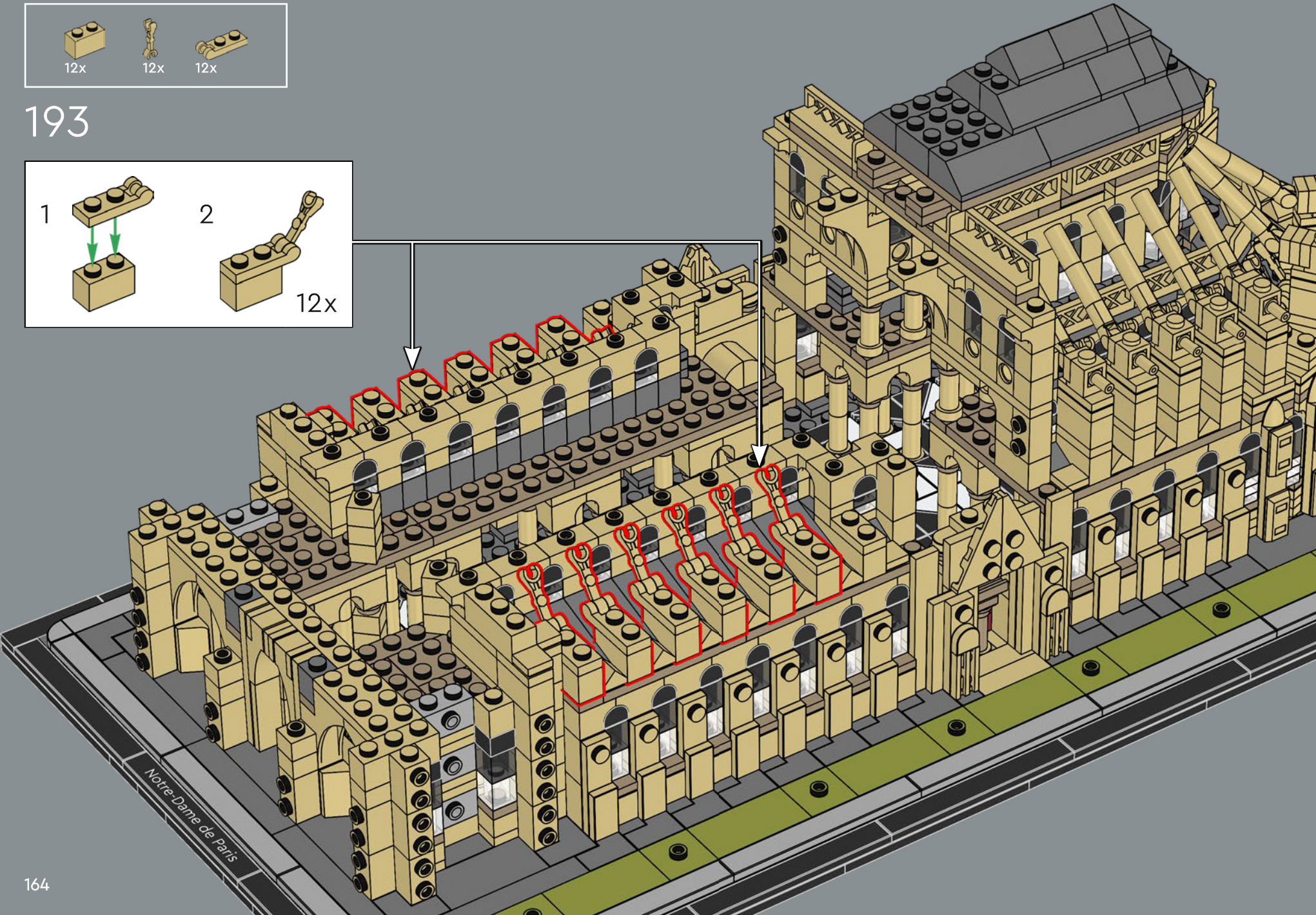
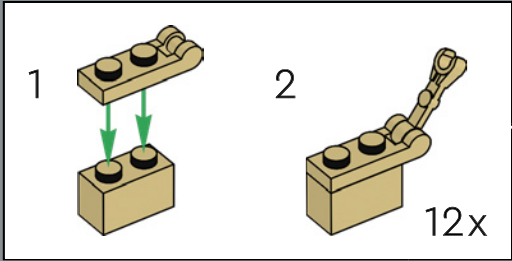



194

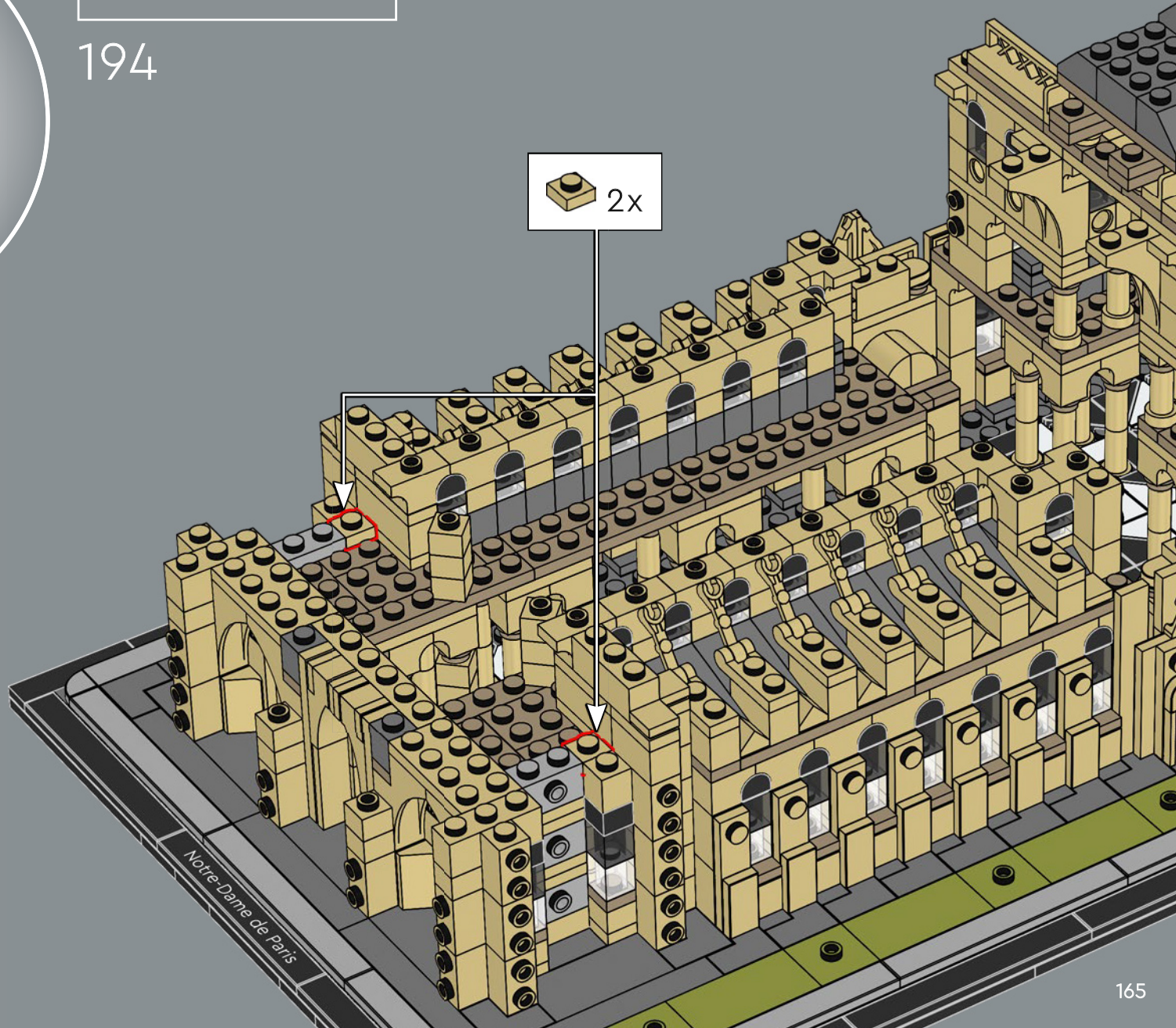

Notre-Dame de Paris

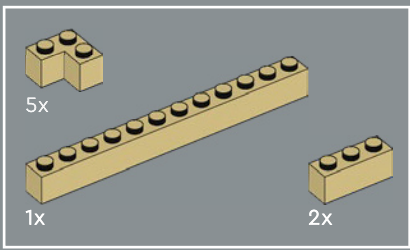

195

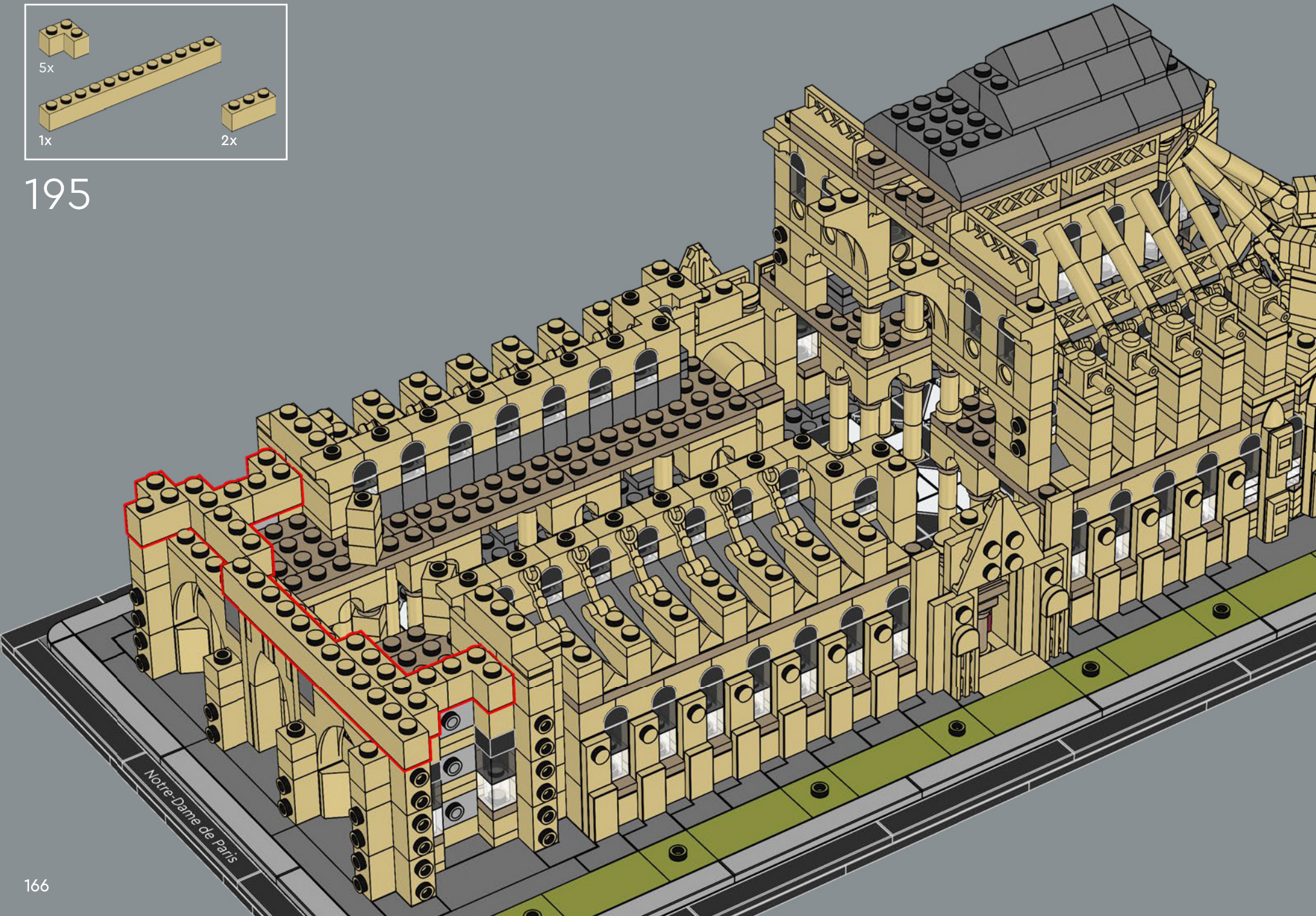

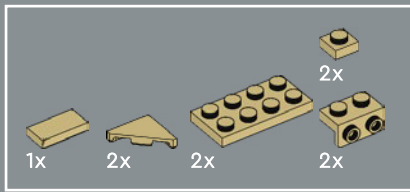

196

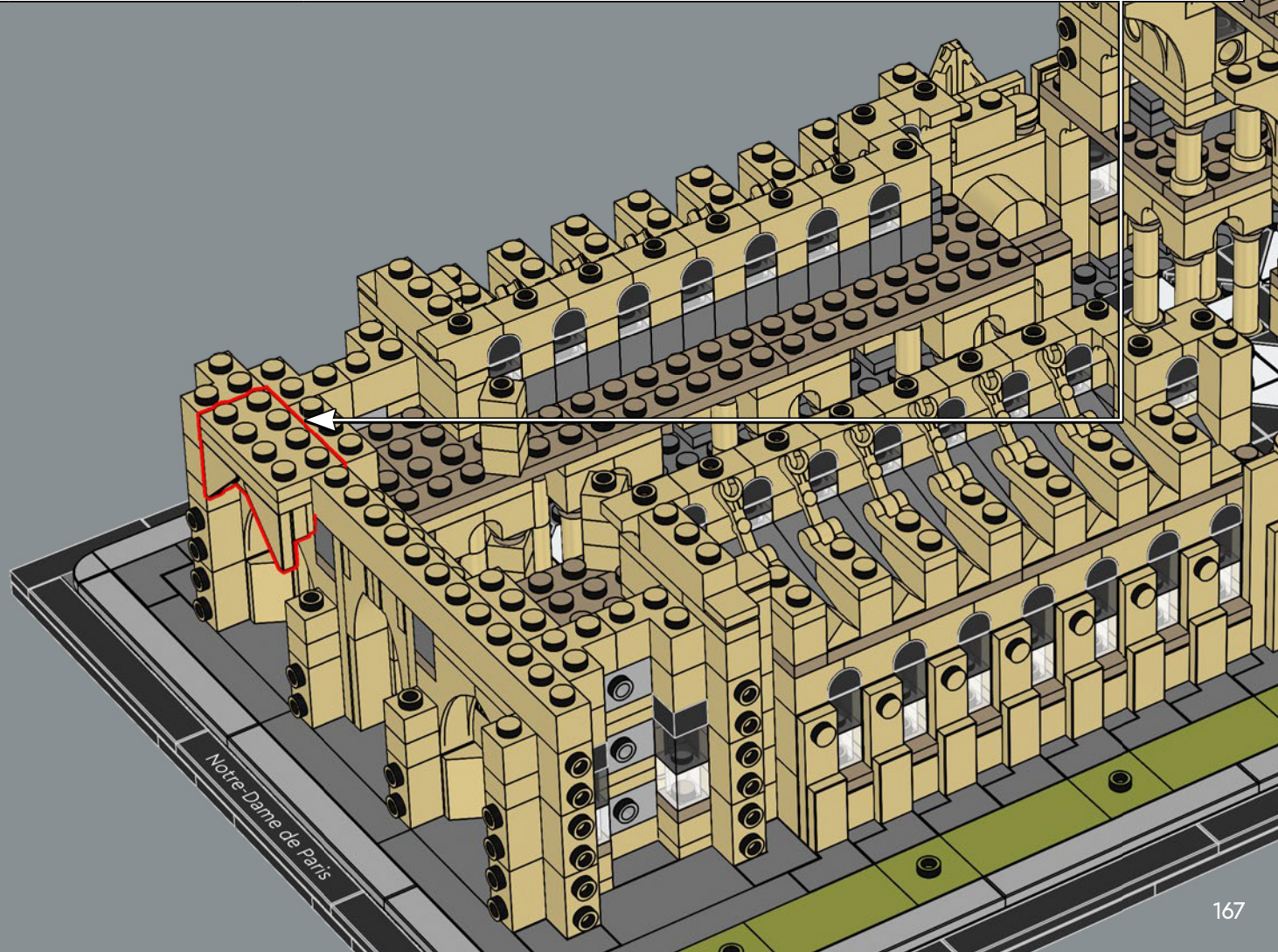
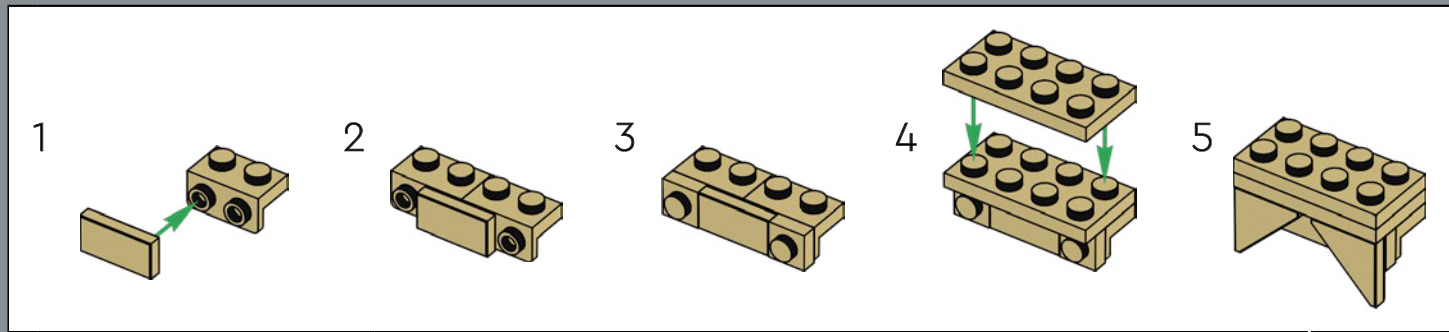

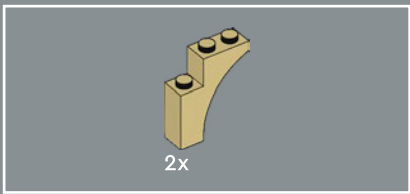

197

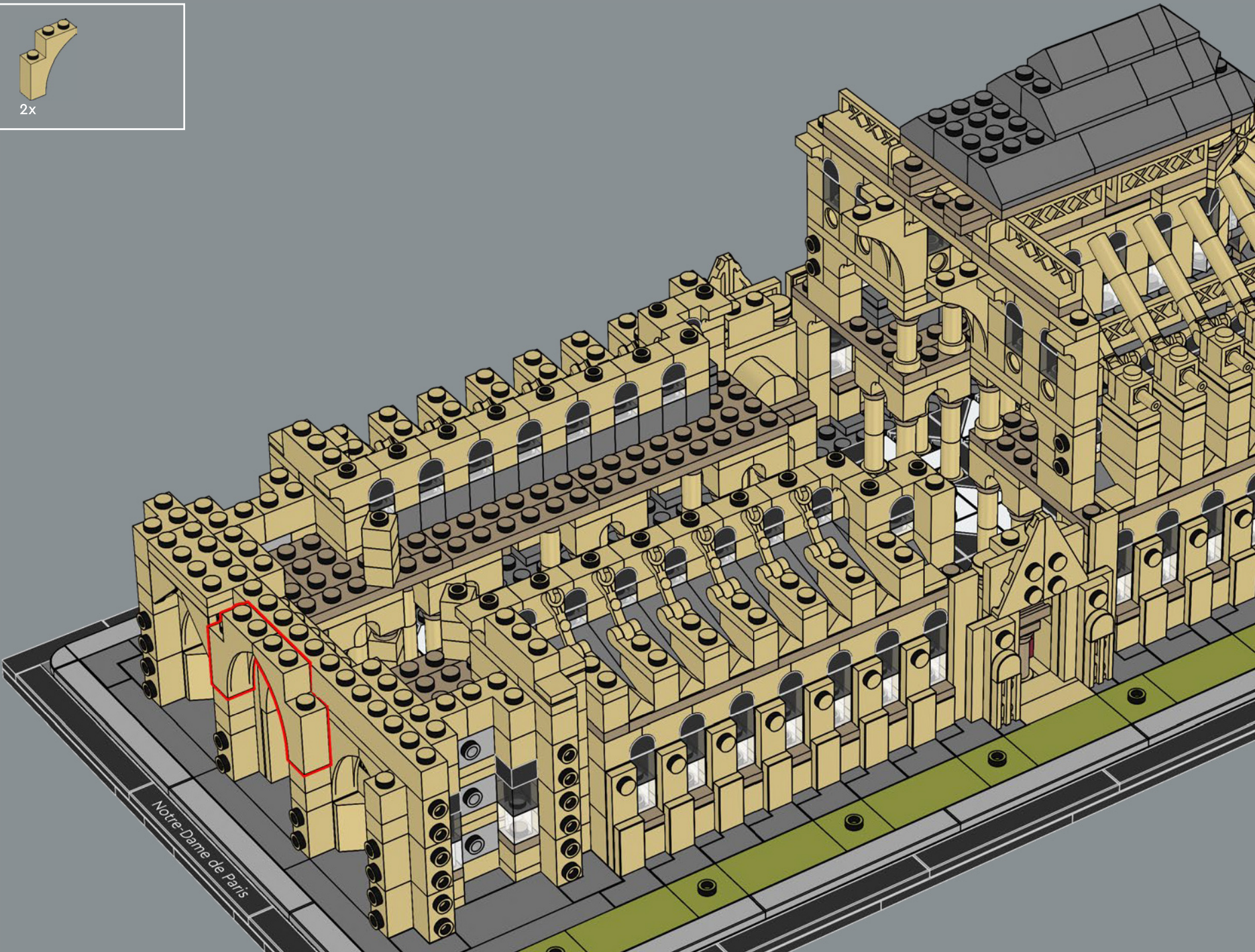

*Notre-Dame de Paris*



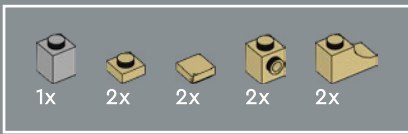

198

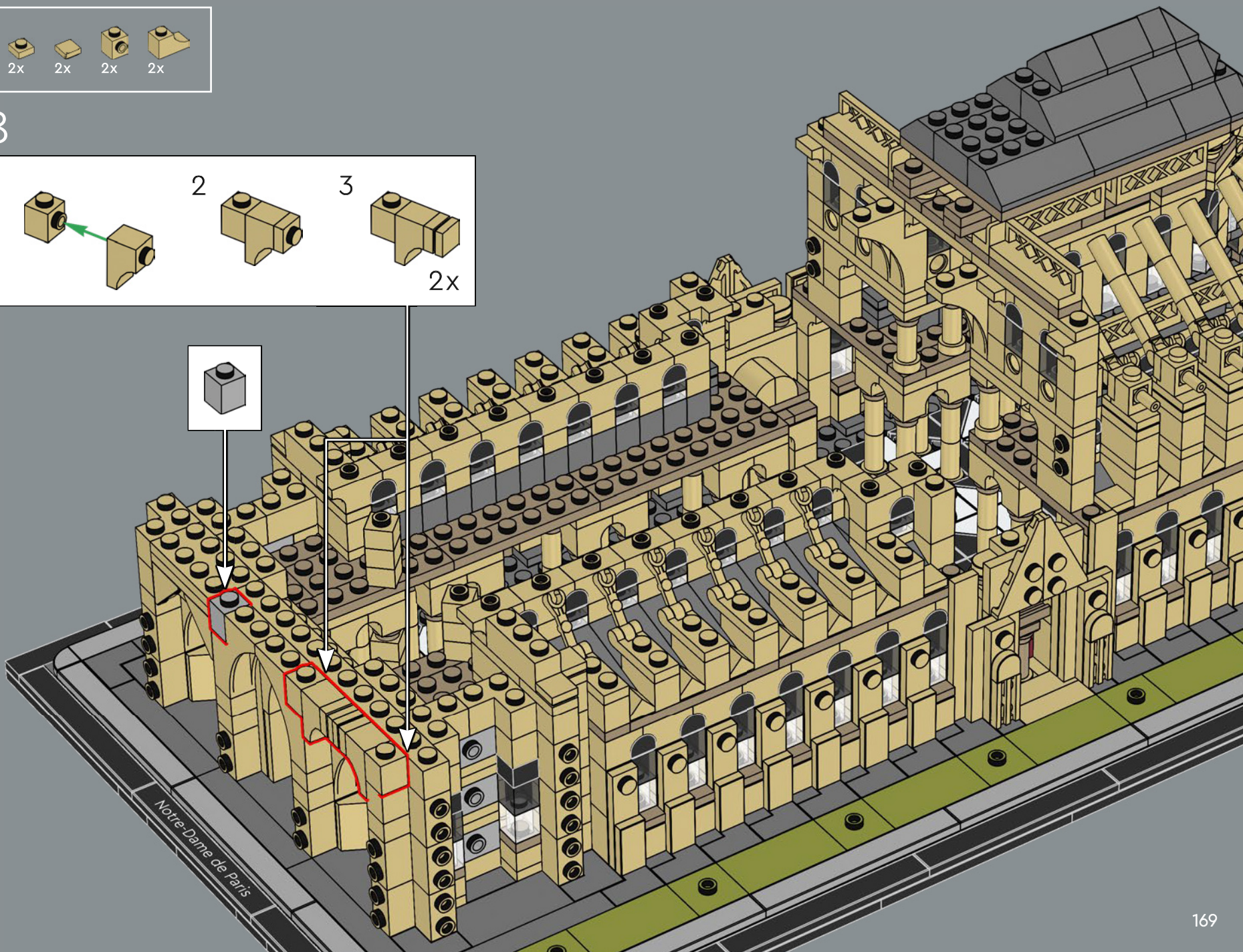
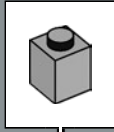
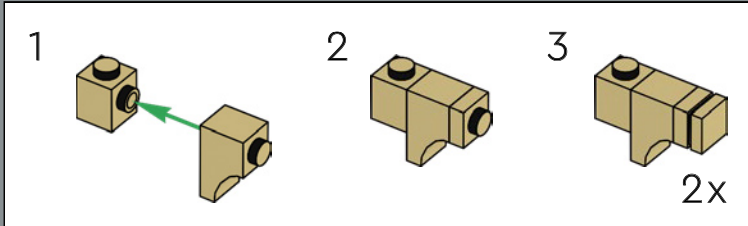

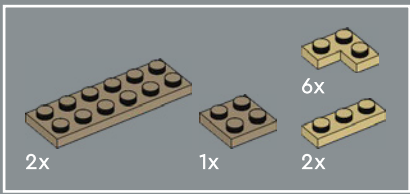

199



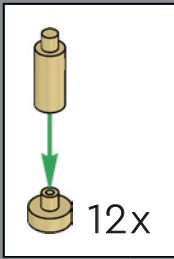

200

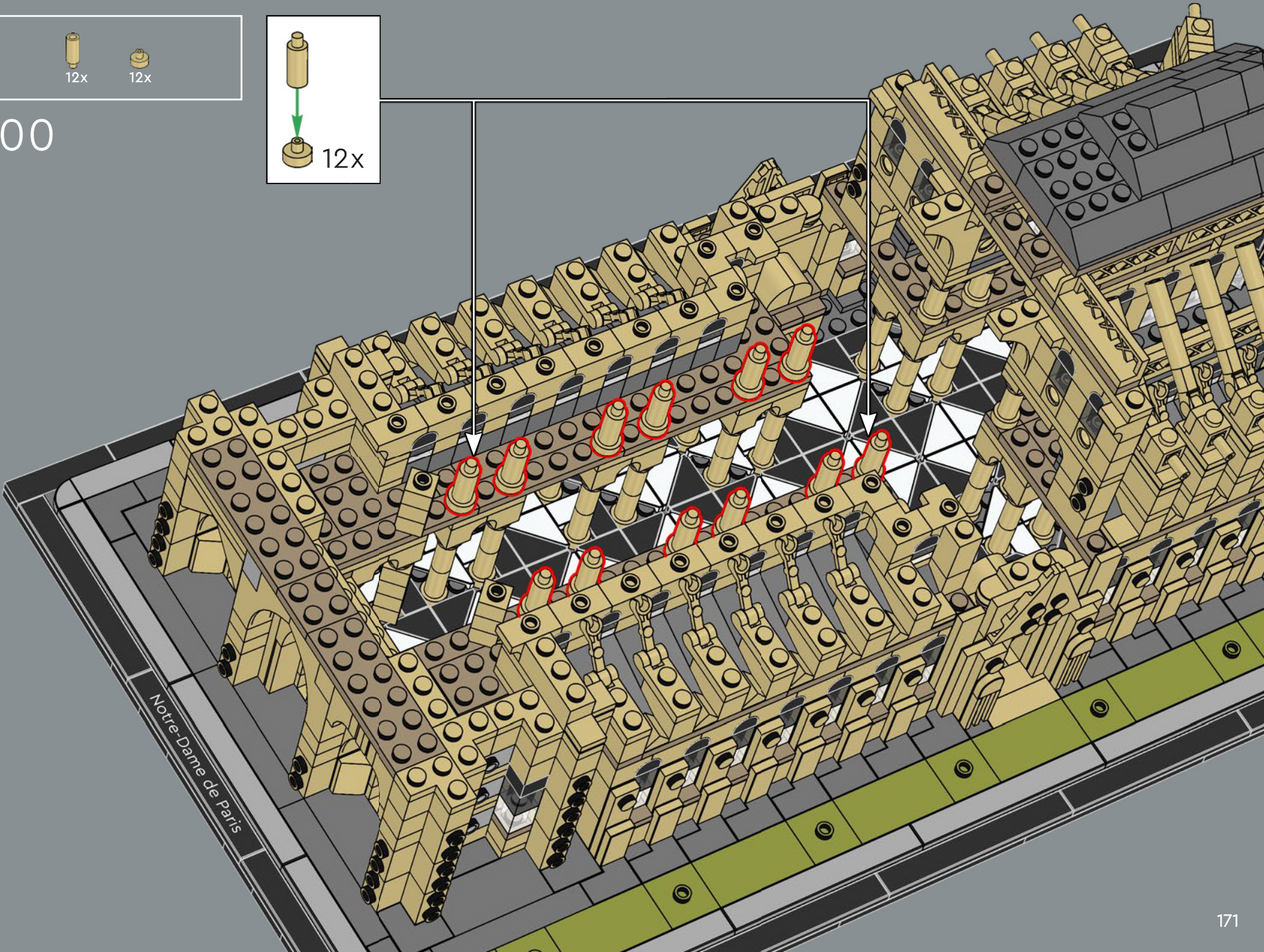

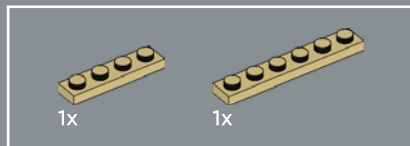
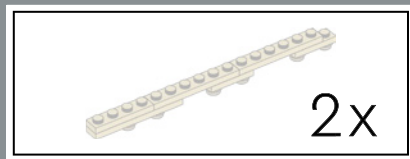

201

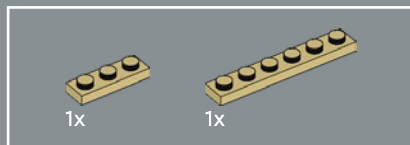
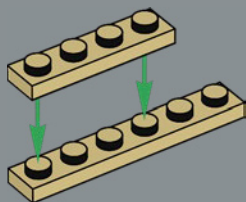

202

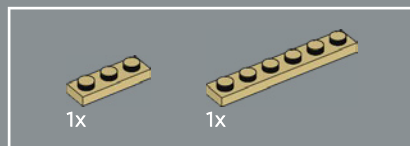
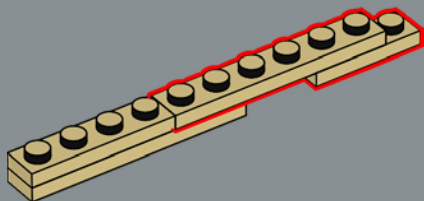

203

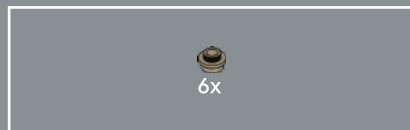
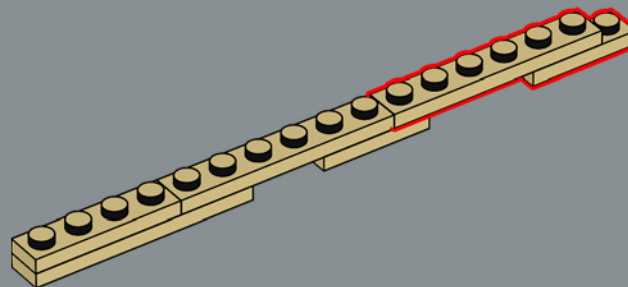

204

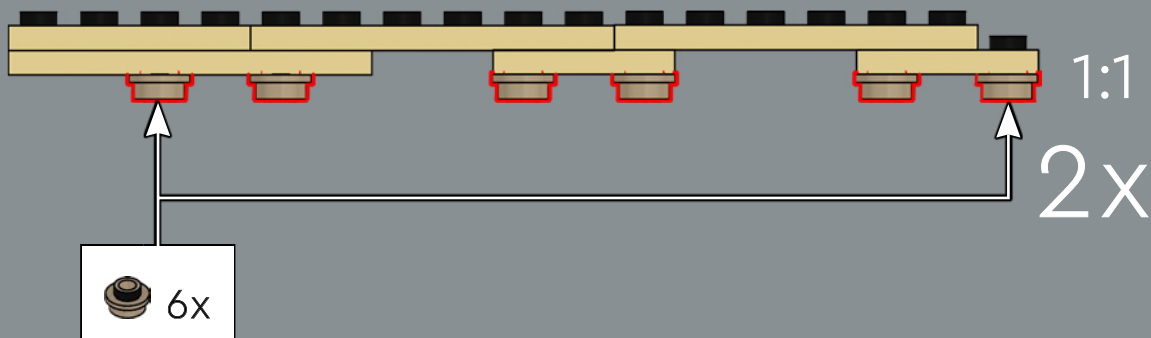

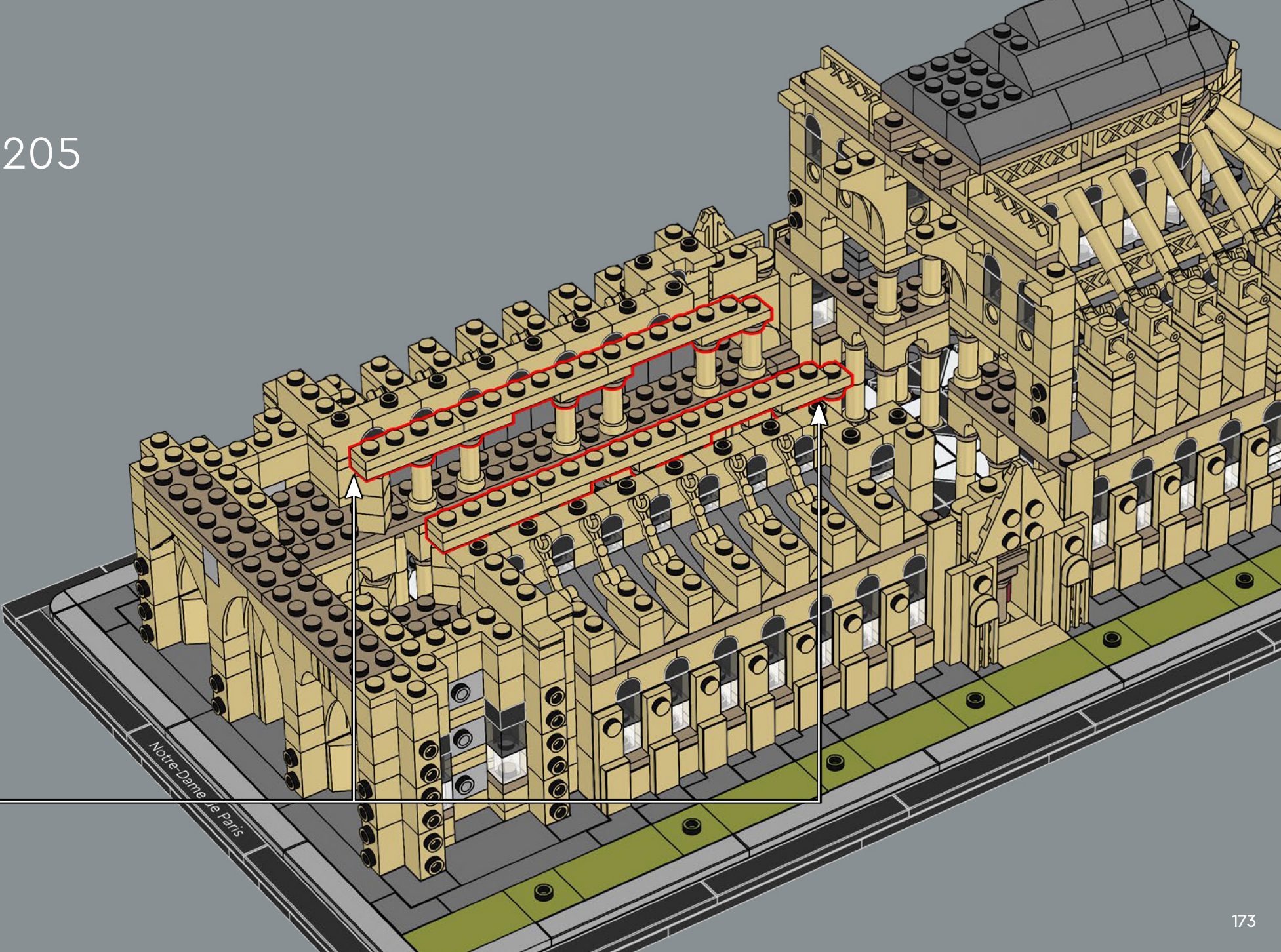

Notre-Dame  
de Paris

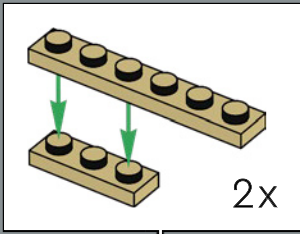
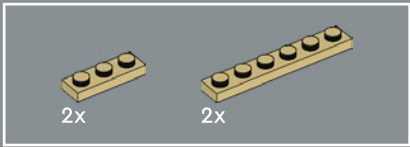

206

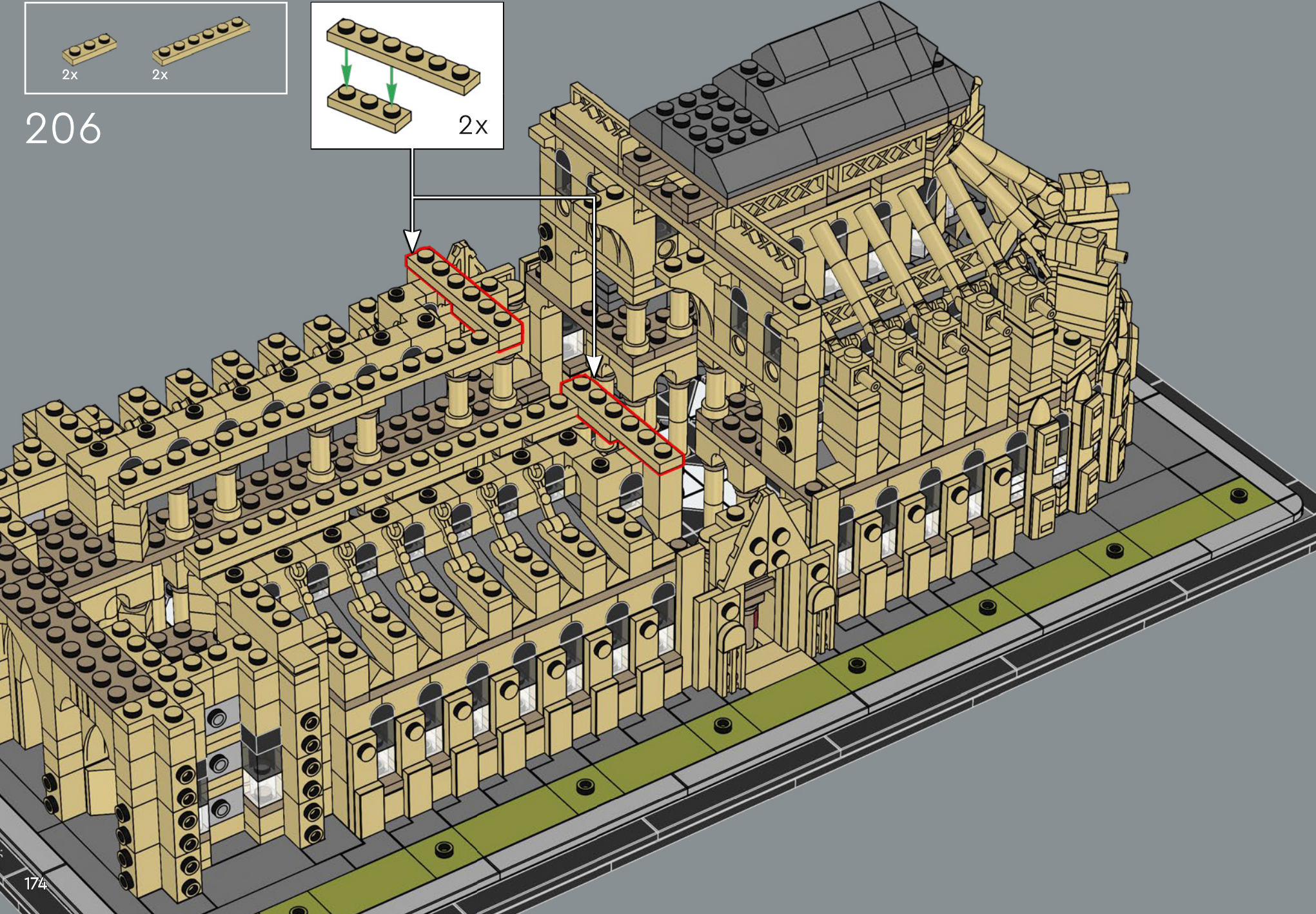

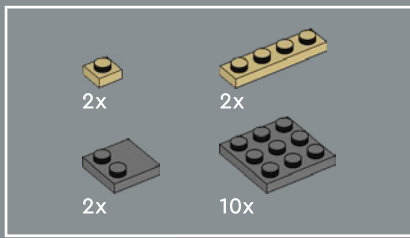

207

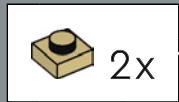

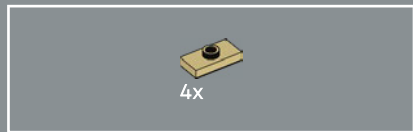

208

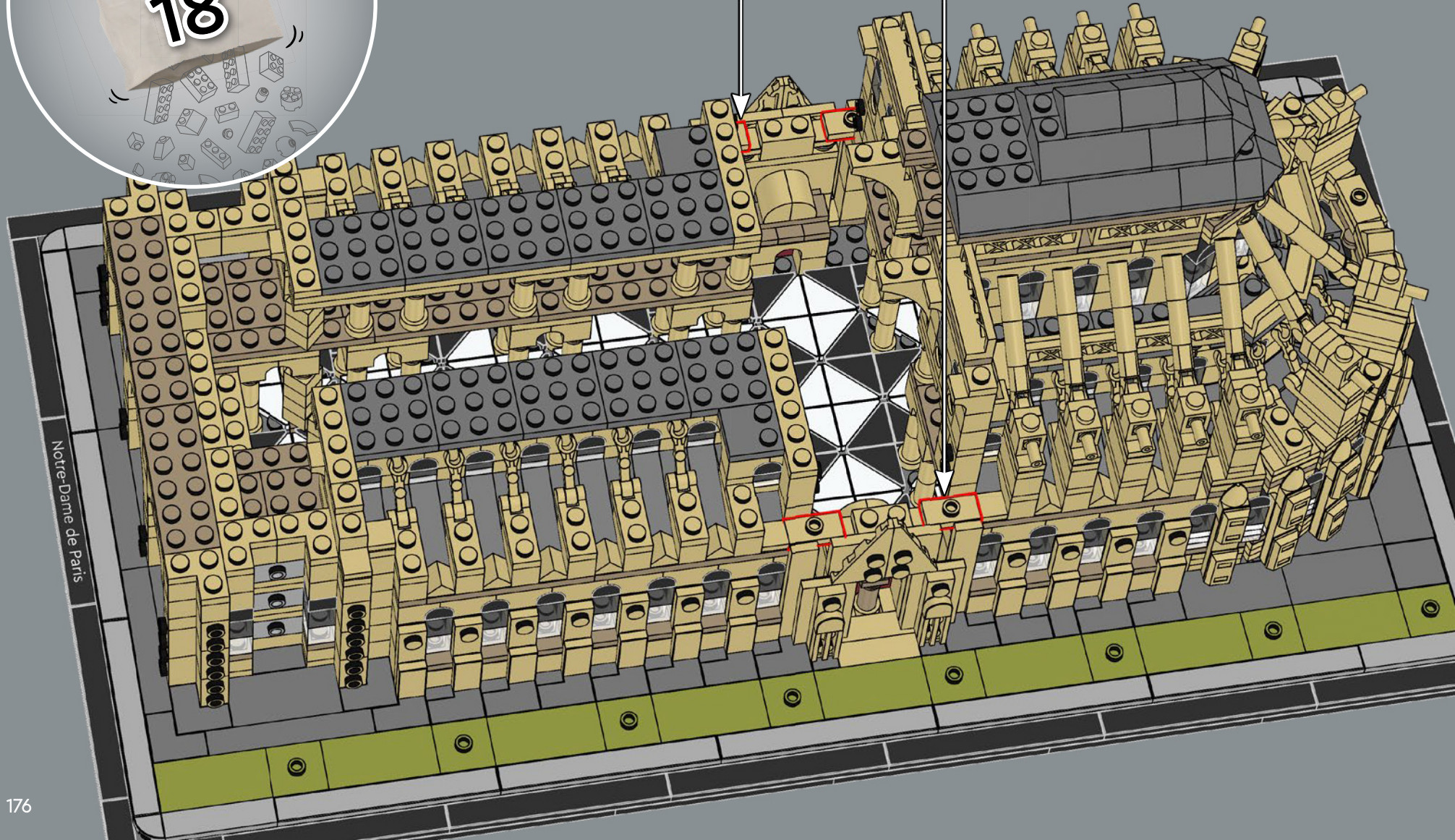



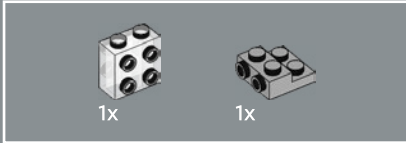
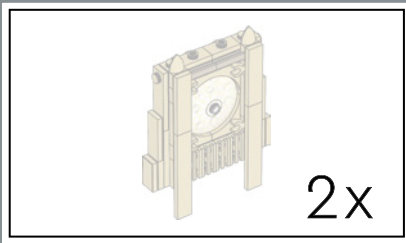

209

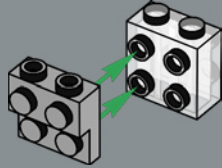

210

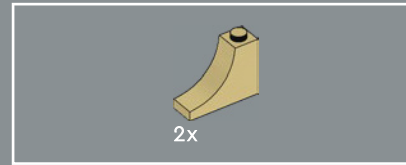
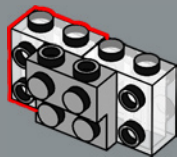

211

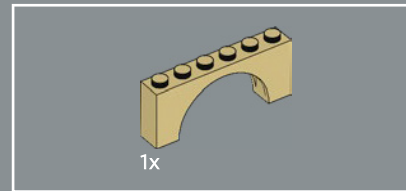
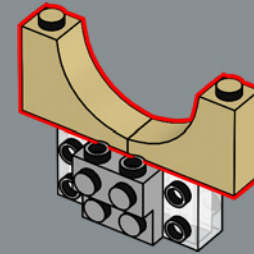

212

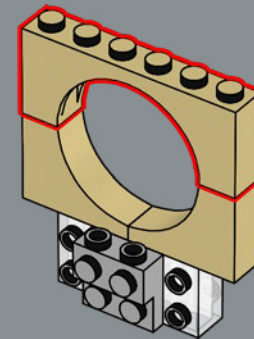

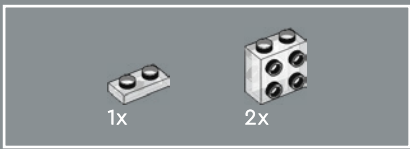

213

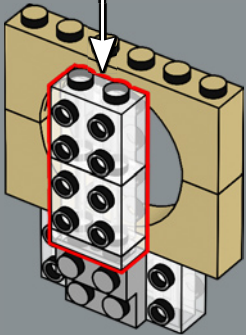
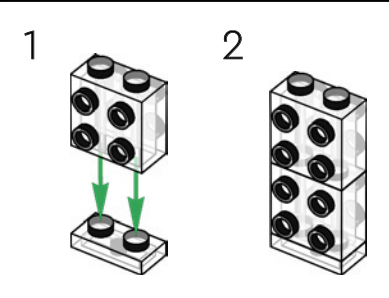

214

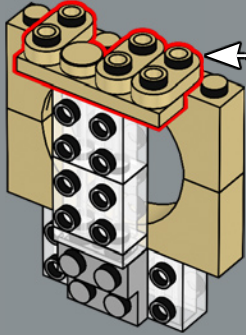
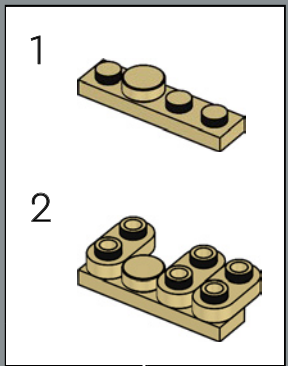

215

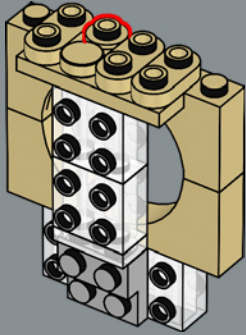

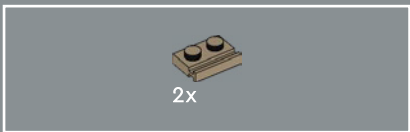

216

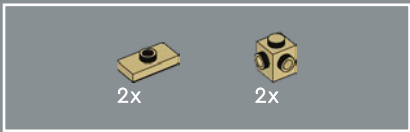
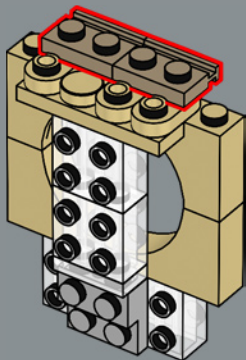

217

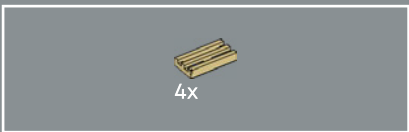
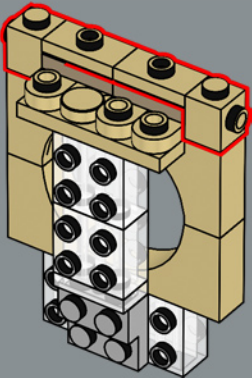

218

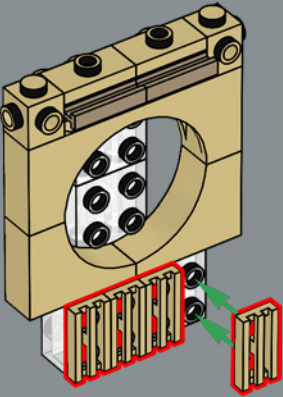

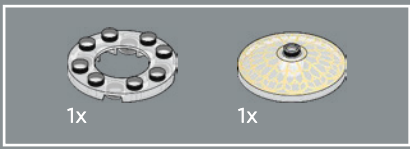

219

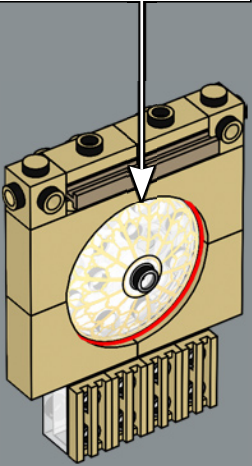
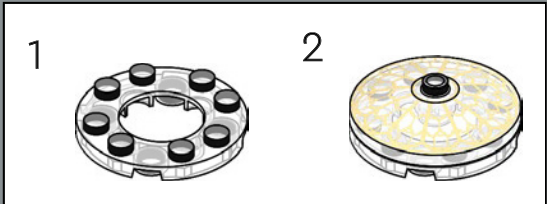

220

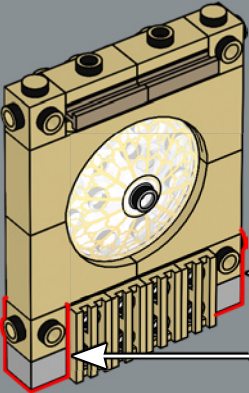
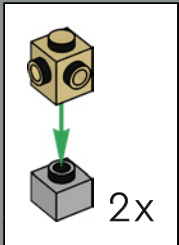

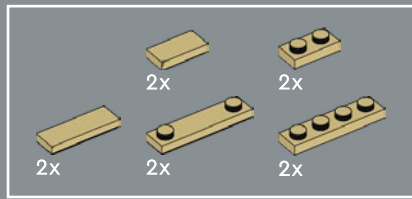

221

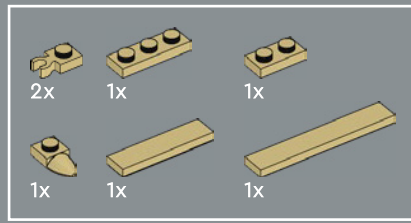
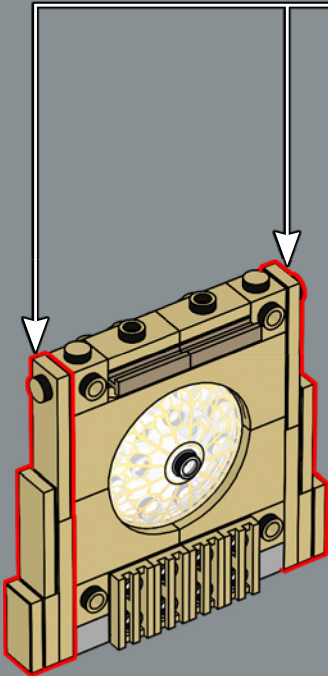
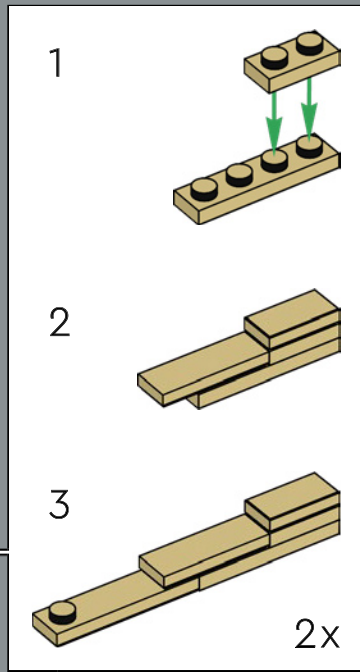

222

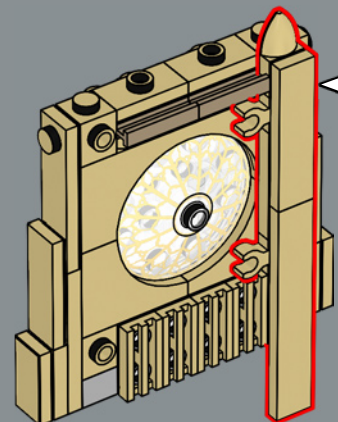
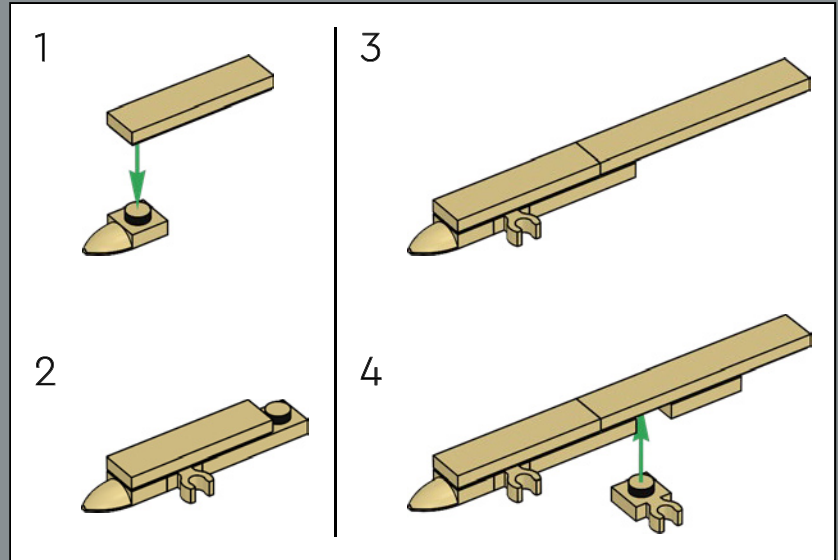

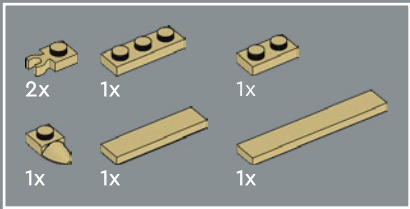

223

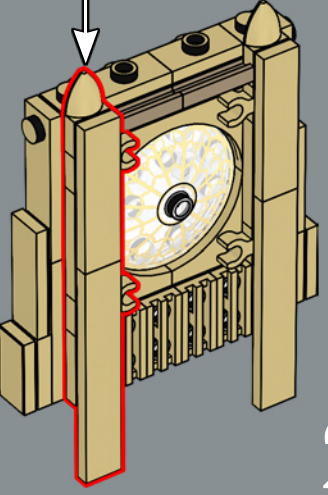
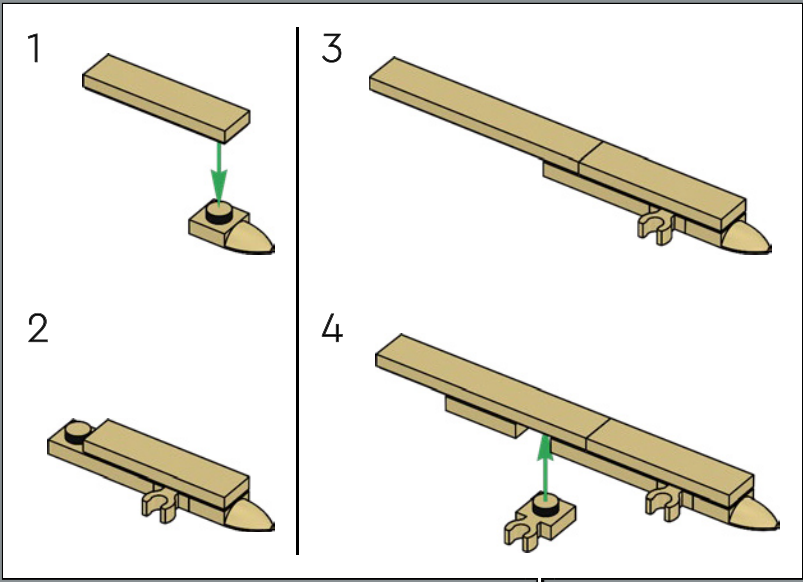

224

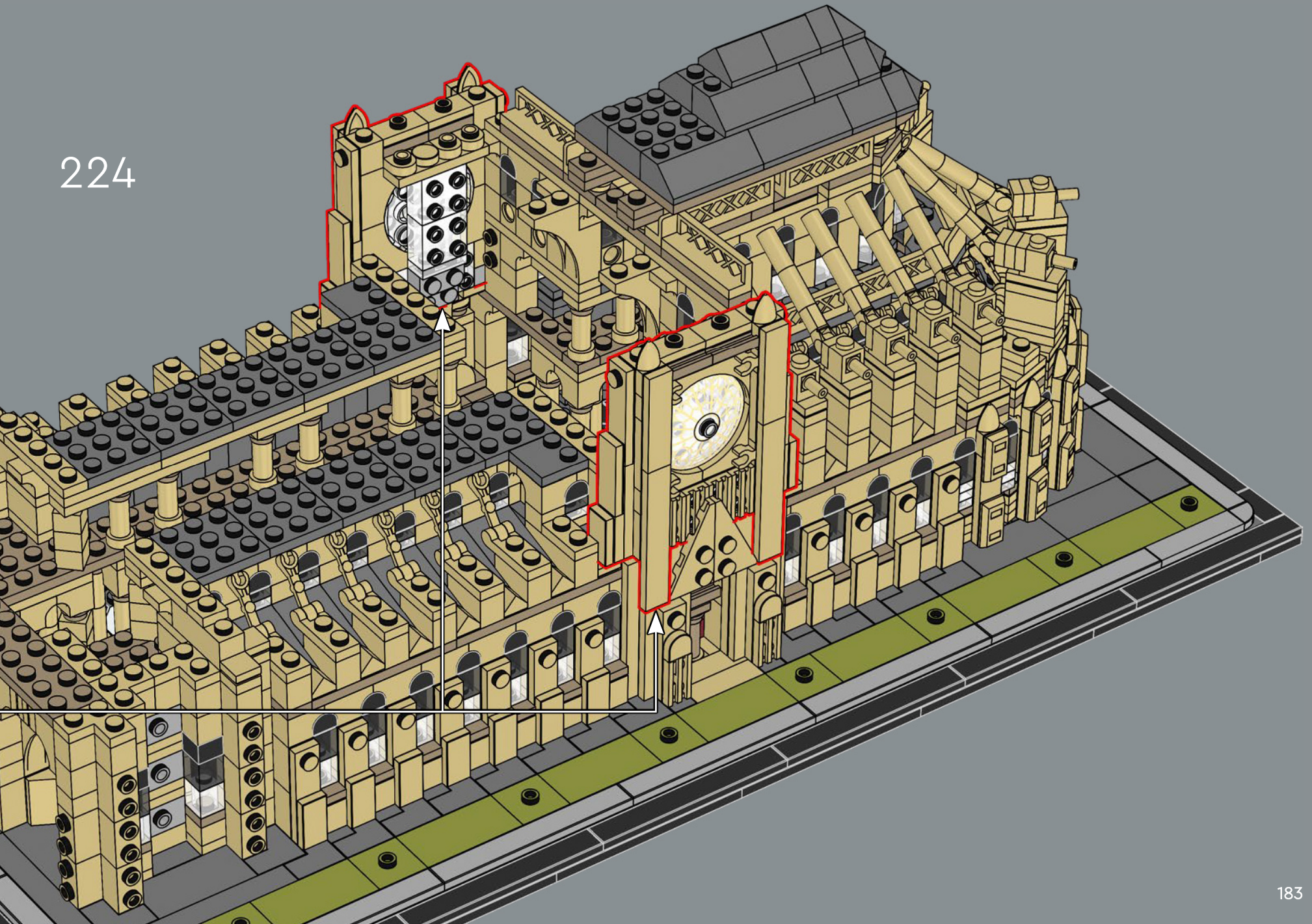

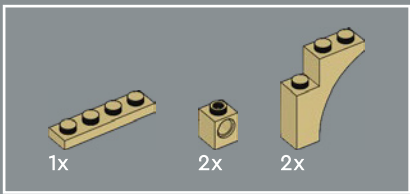

225

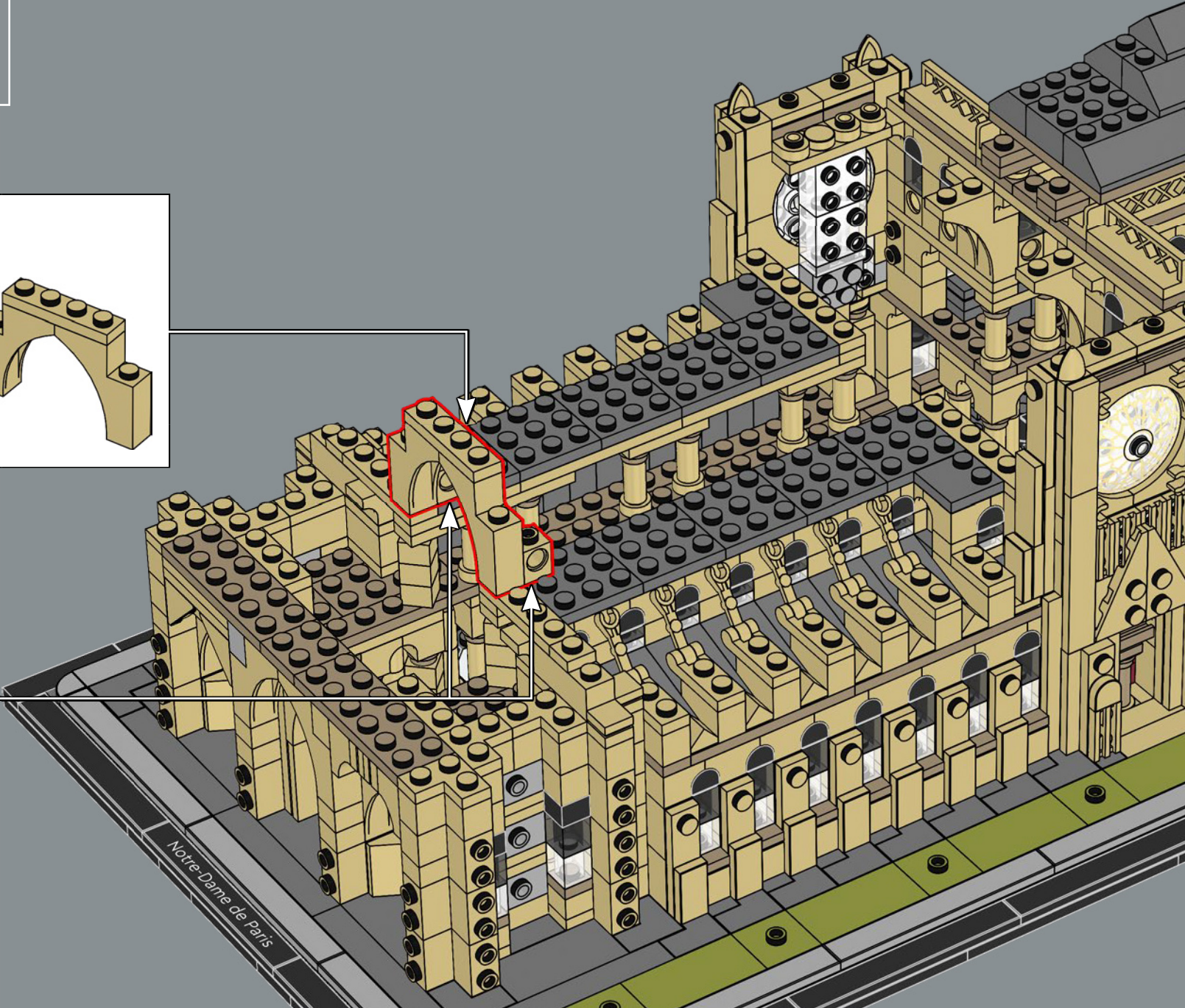
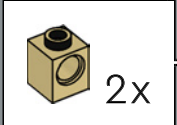
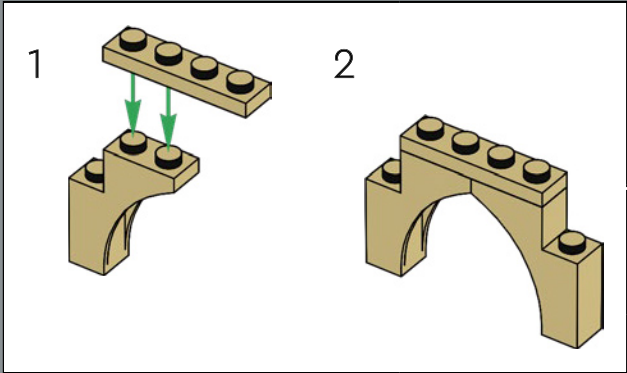



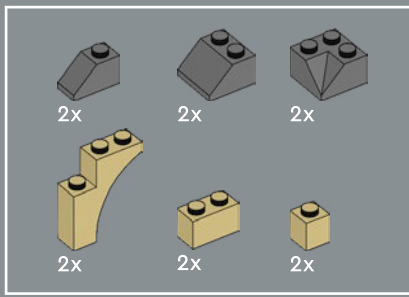

226

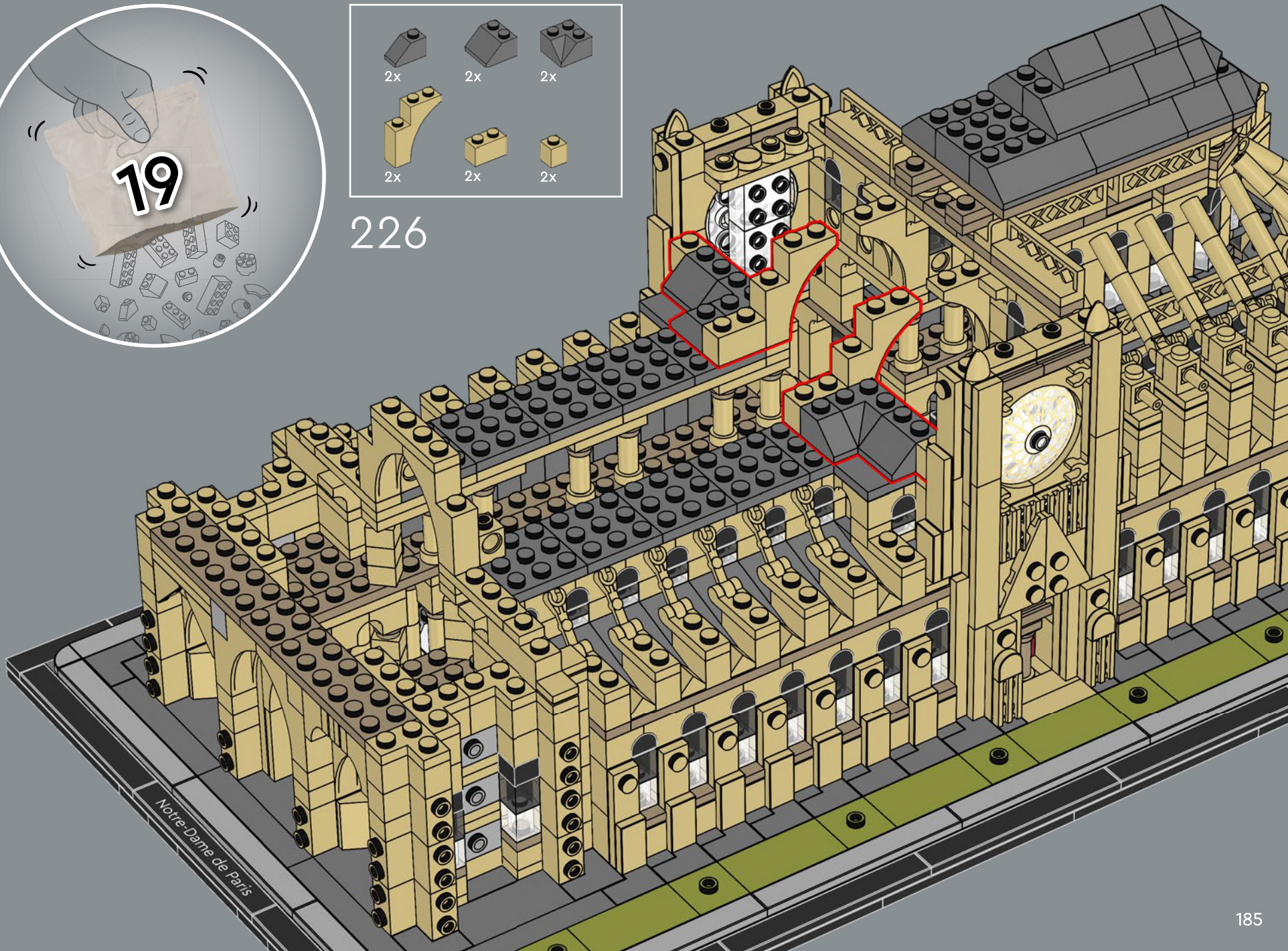



8x

227

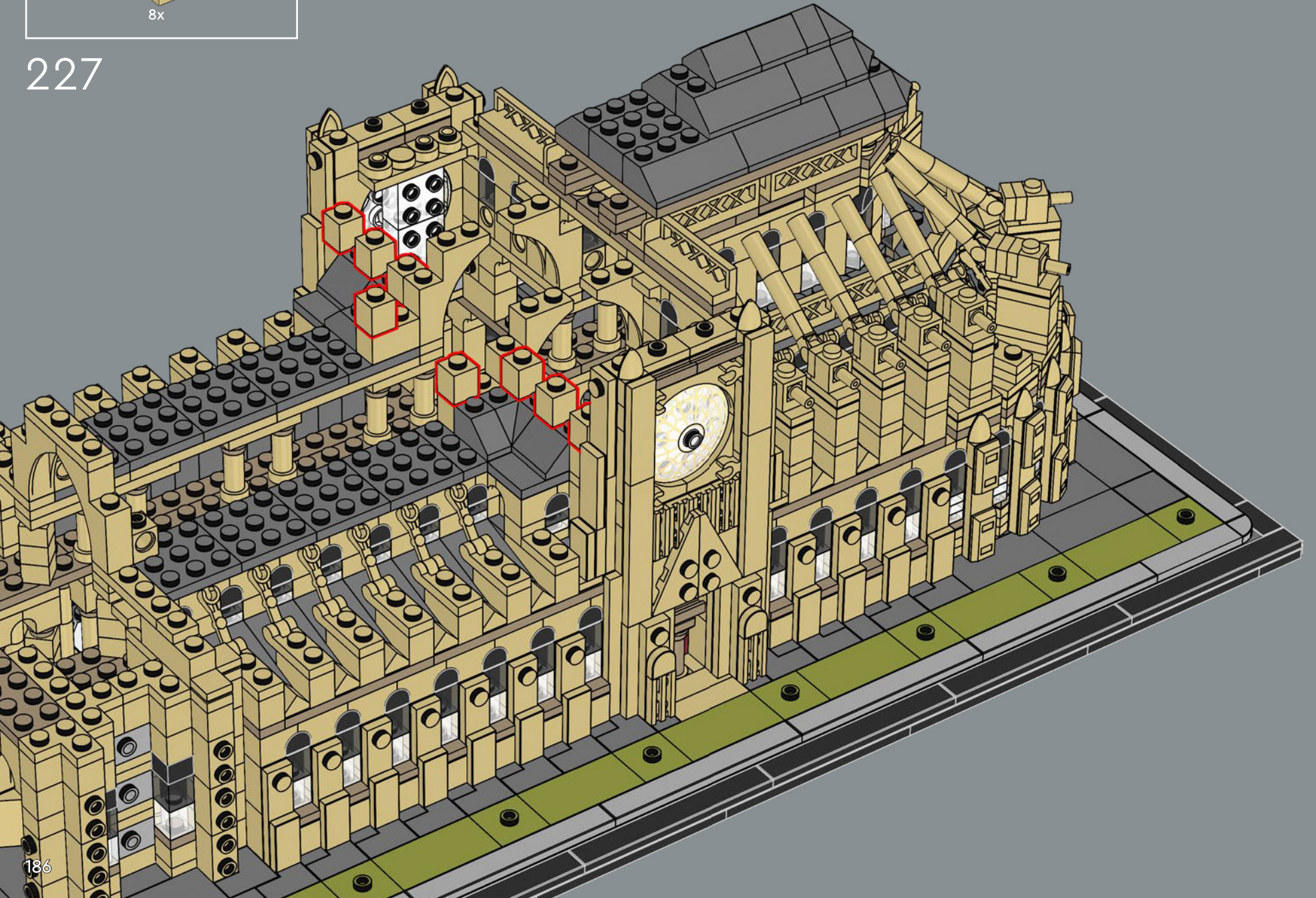

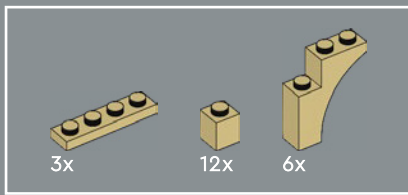

228

Die Gewölbe sind durch Spanten in sechs Teile unterteilt und werden als „sechsteilige Gewölbe“ bezeichnet. Im LEGO® Modell gibt es eine Querspante an jedem zweiten Kapitell, um das Original nachzubilden.

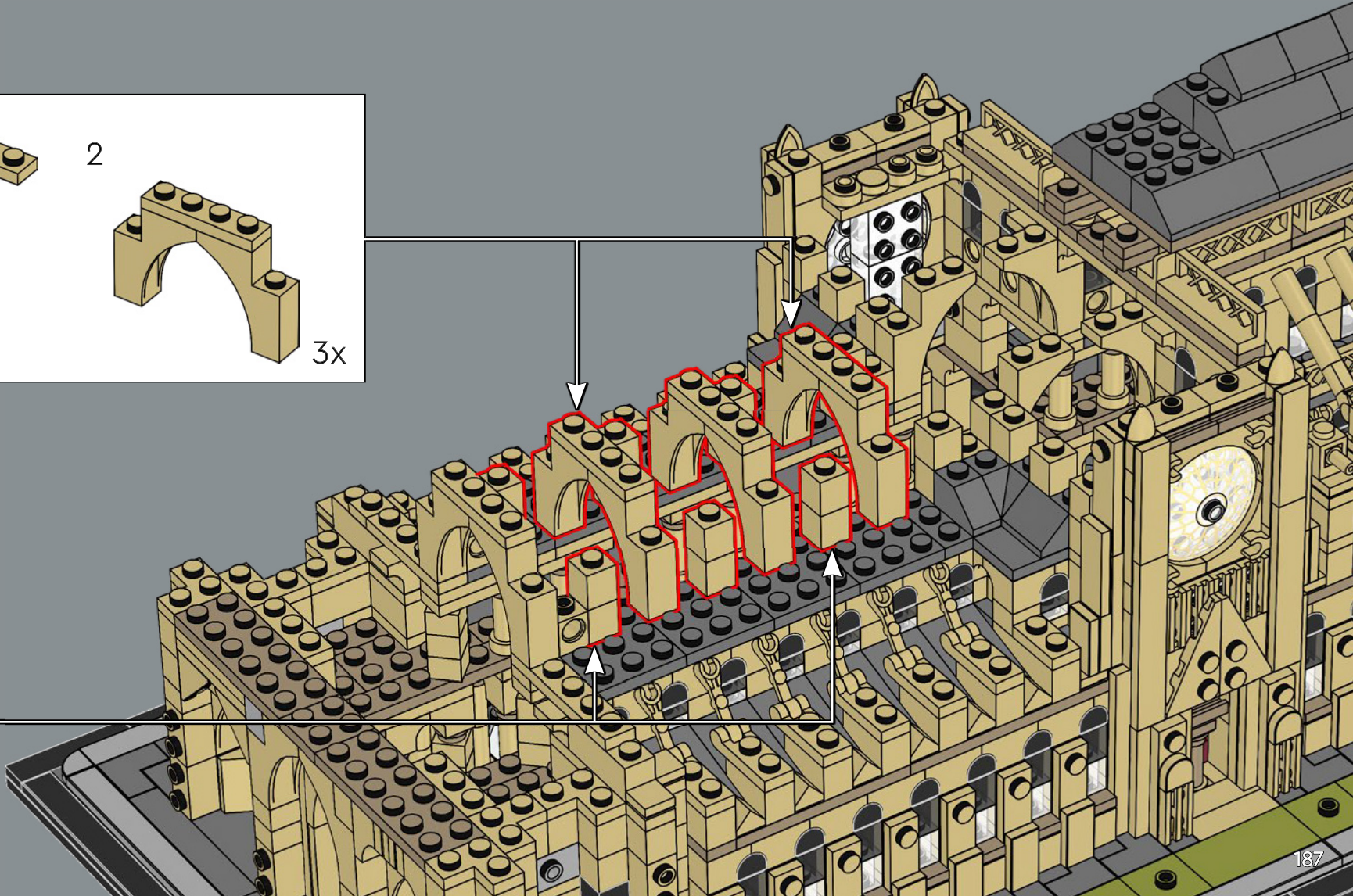
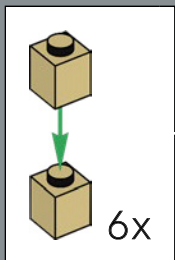
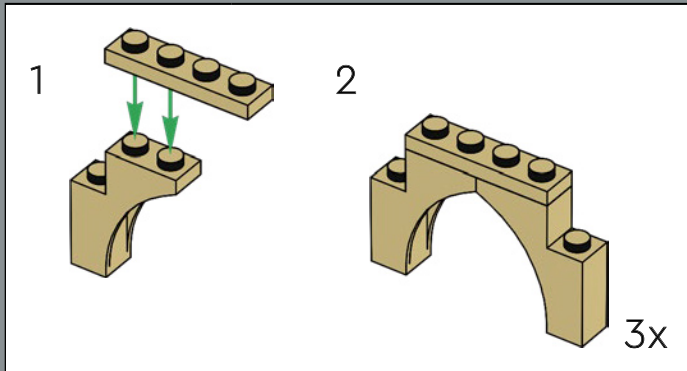



12x



20x



20x

229



8x



12x

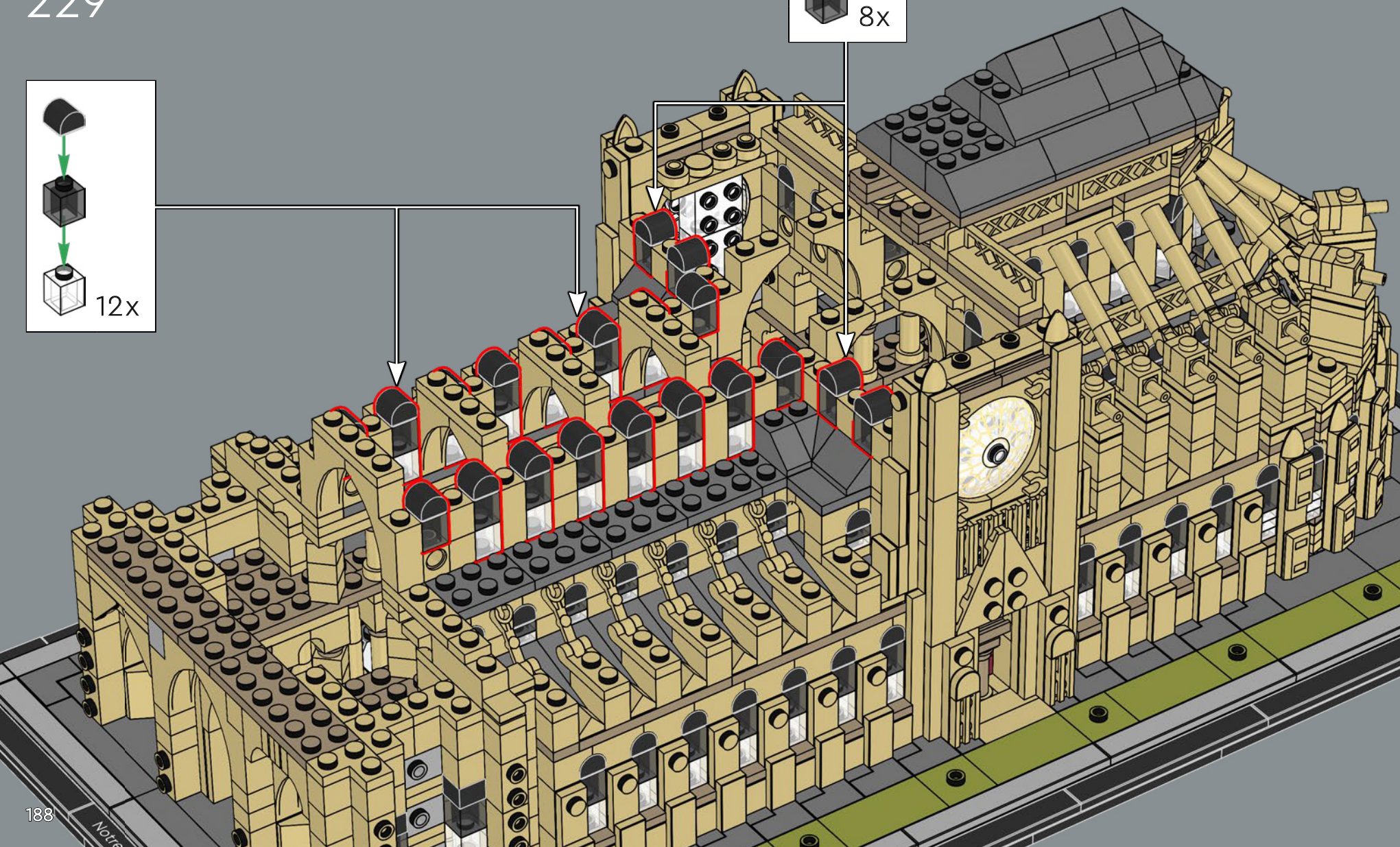

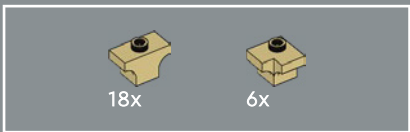

230

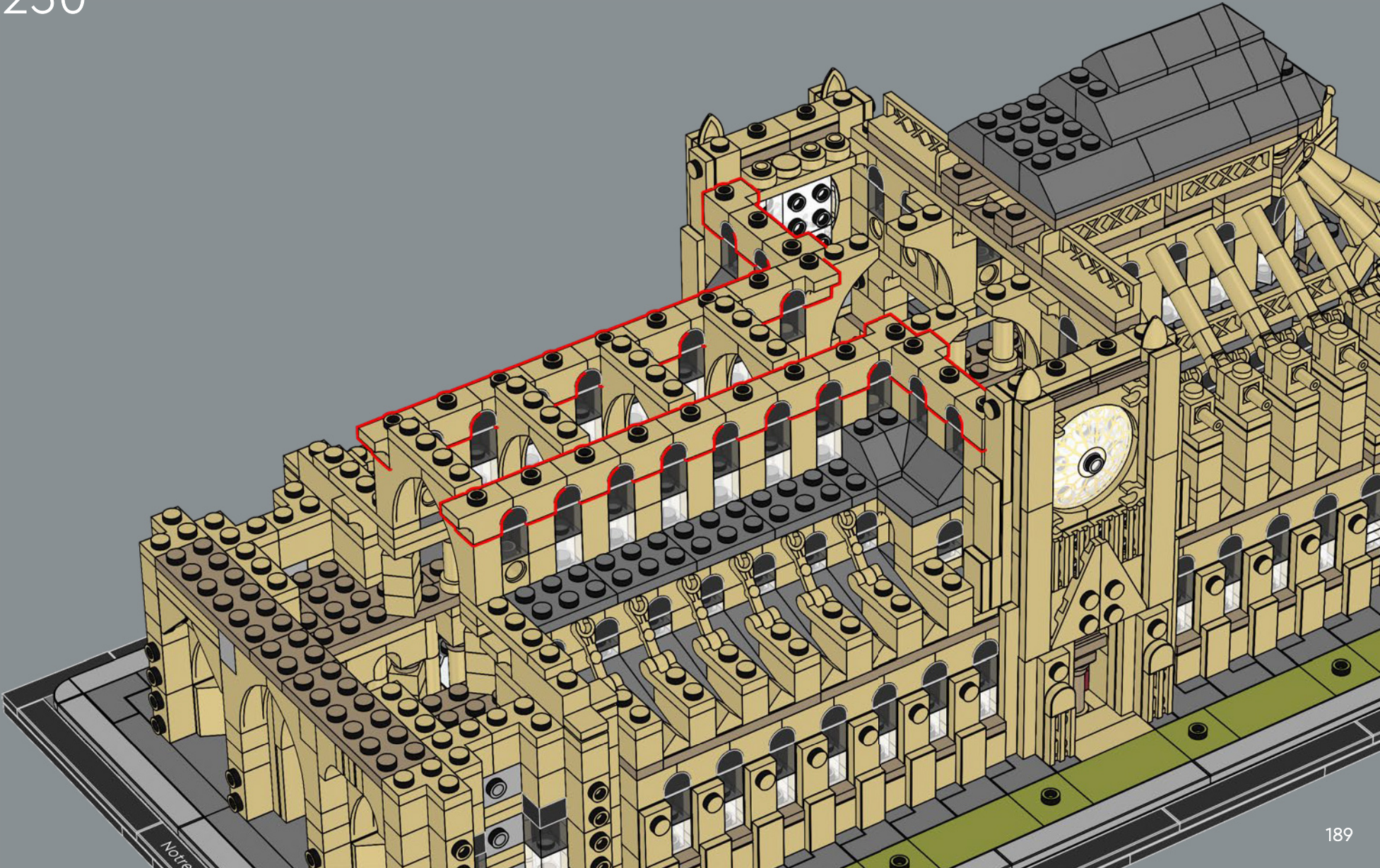

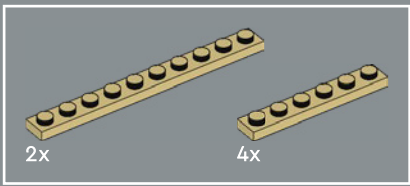

231

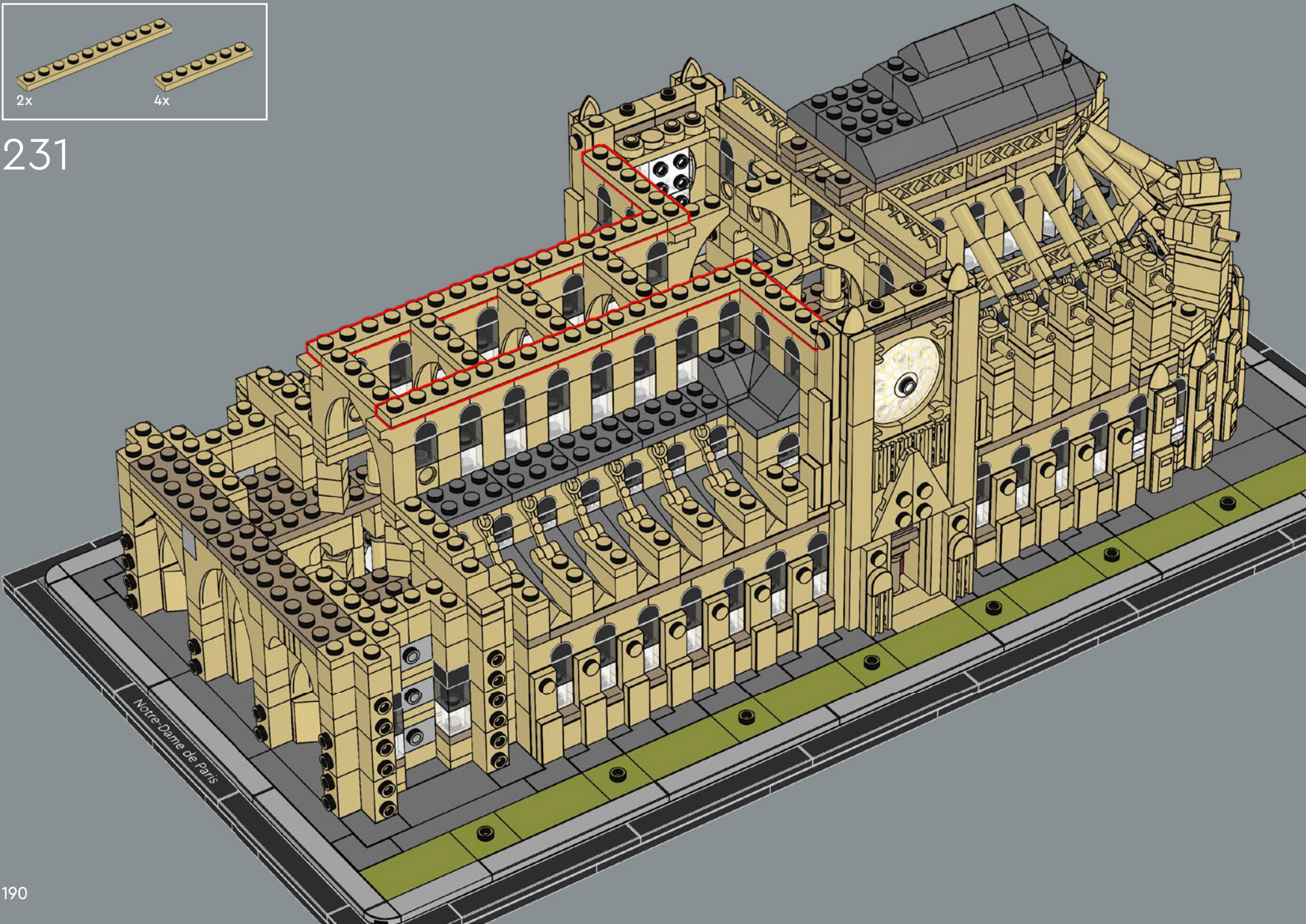

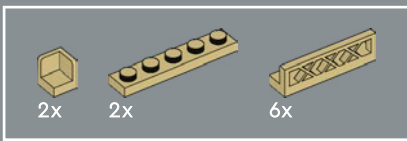

232

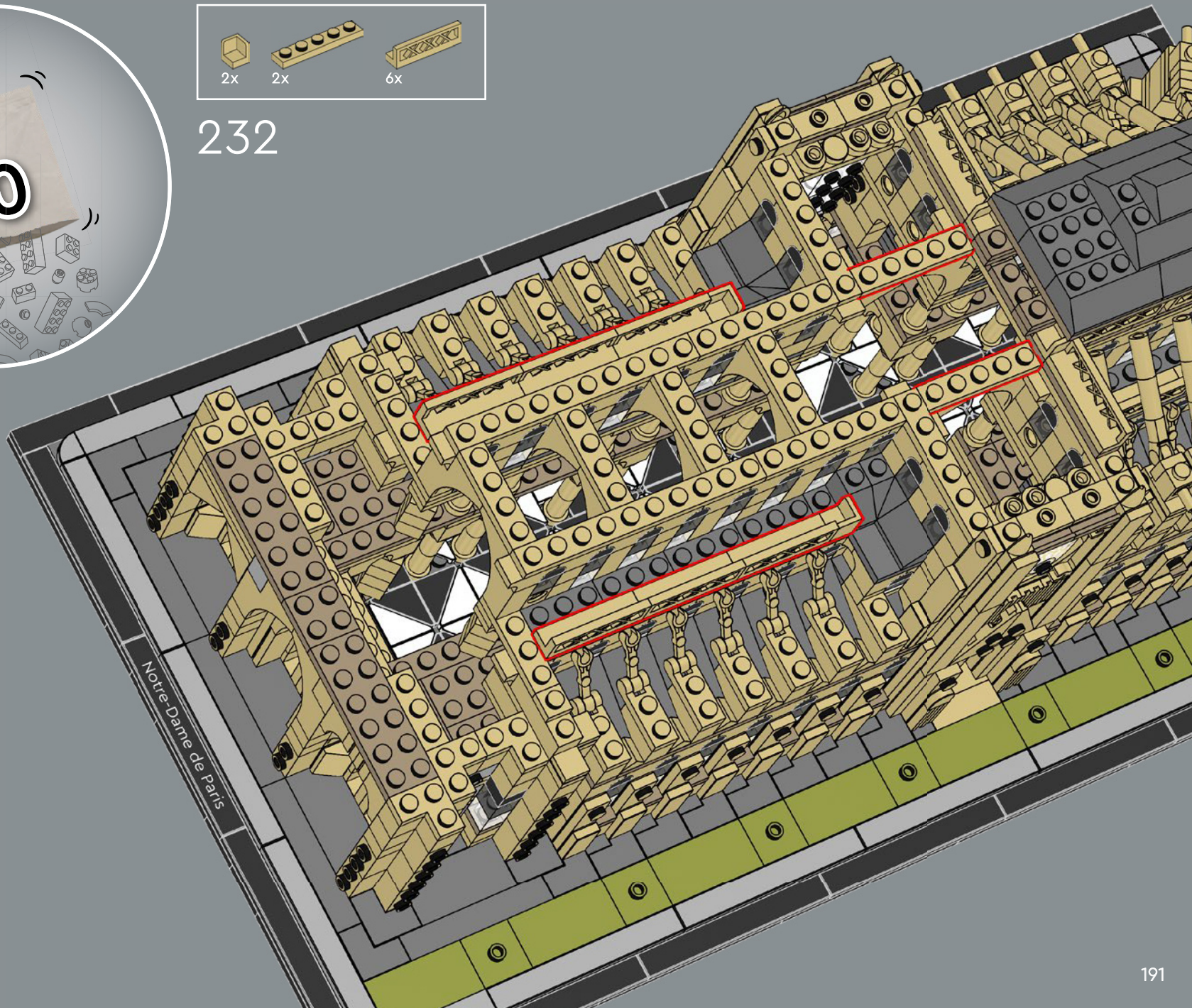

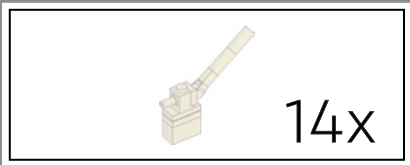

In den Hochschiffstreben dieses LEGO® Modells befinden sich Löcher in den Kerzelementen, die den Wasserrinnen in den echten Strebebögen nachempfunden sind.

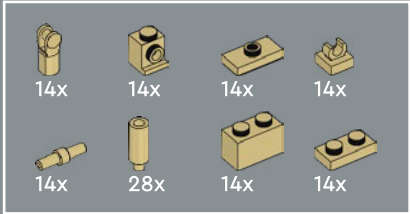

233

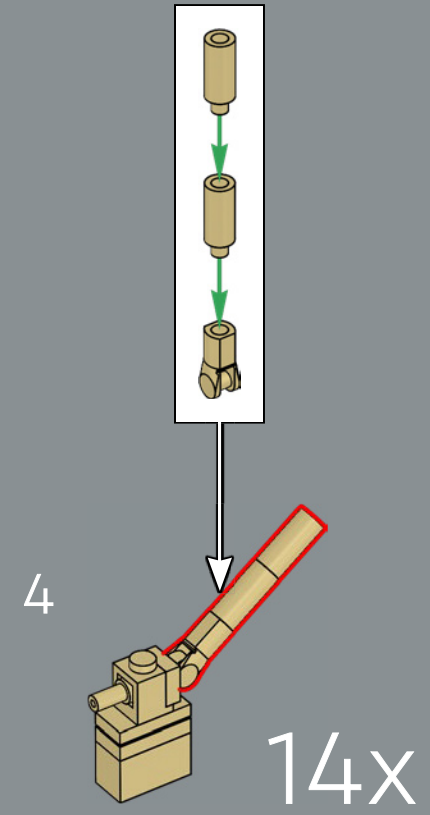
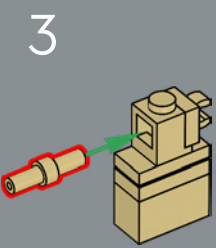
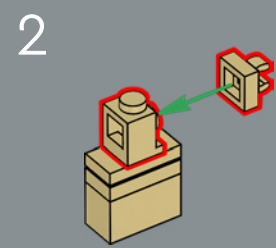
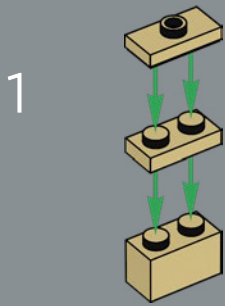



Im Jahr 1225 werden die Streben im Hauptschiff mit Rinnen versehen, damit das Regenwasser vom Dach durch die Wasserspeier ablaufen kann.

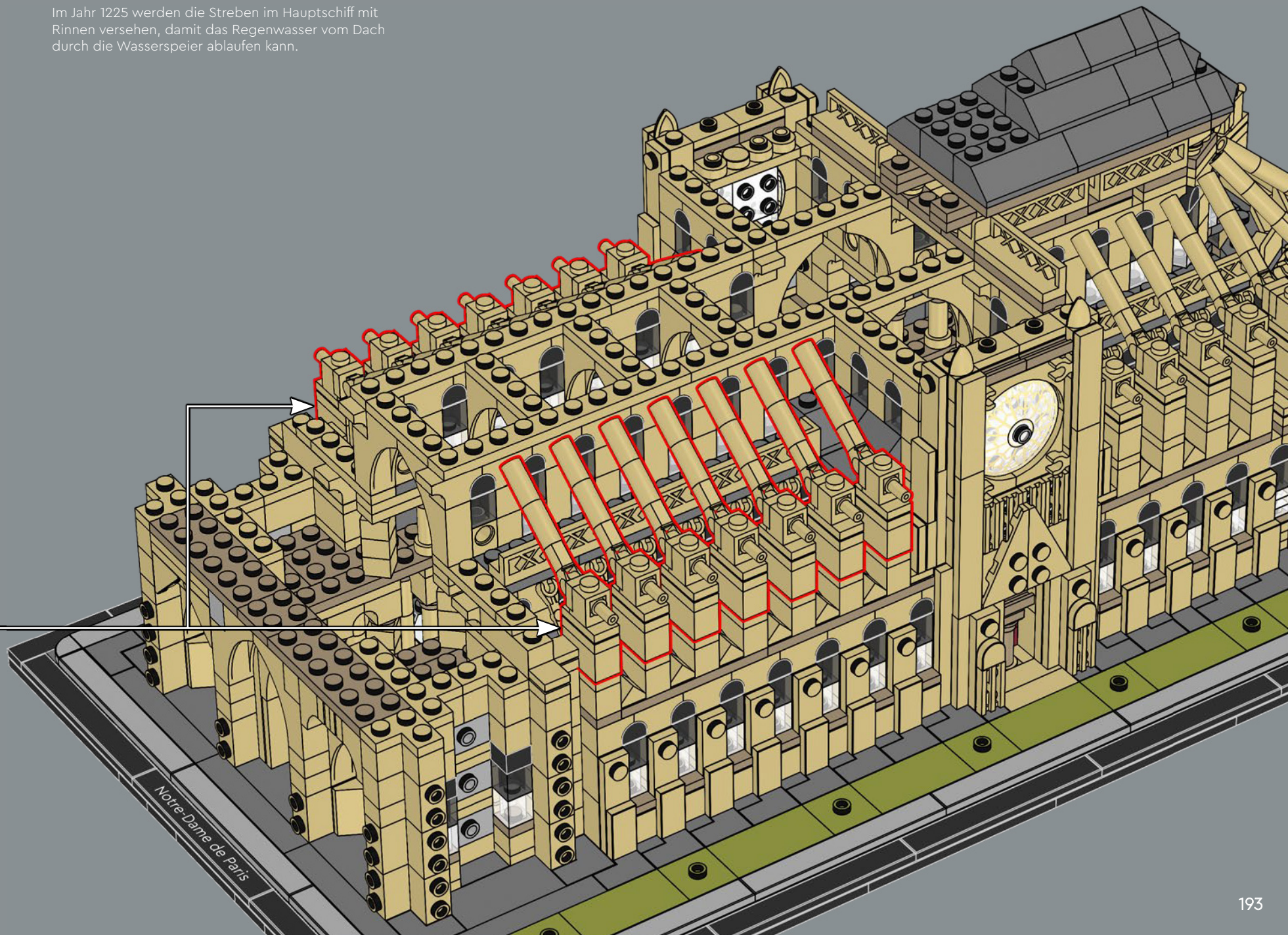

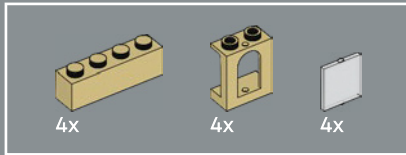
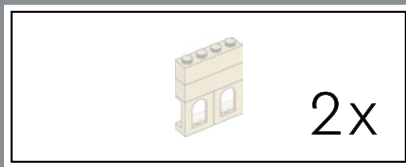

234

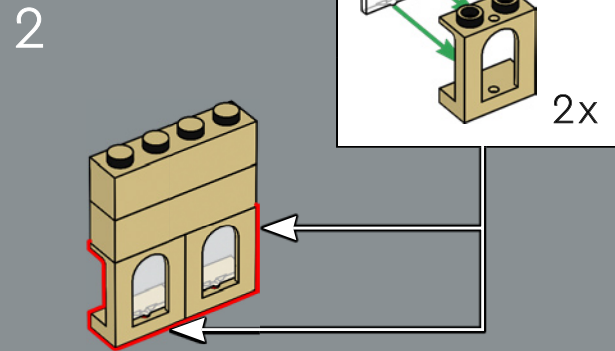
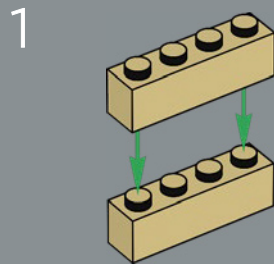

2x

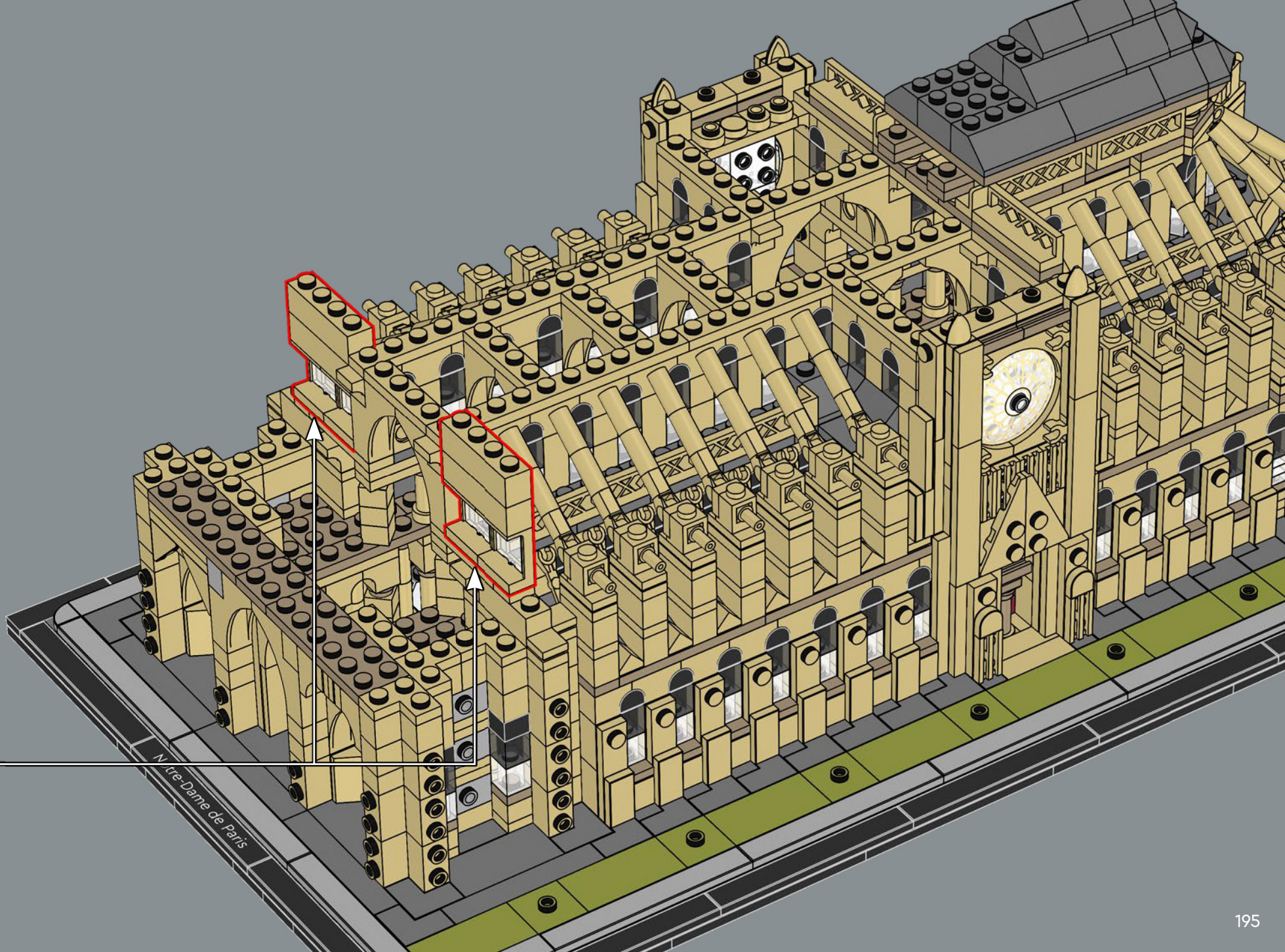

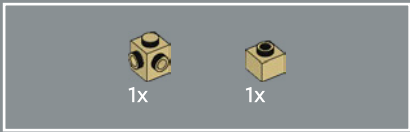

235

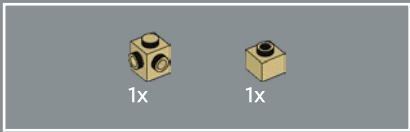
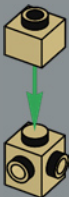

236

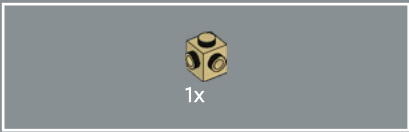

237

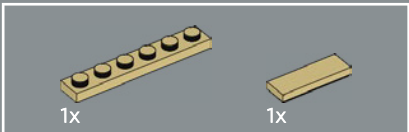

238

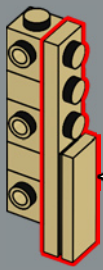
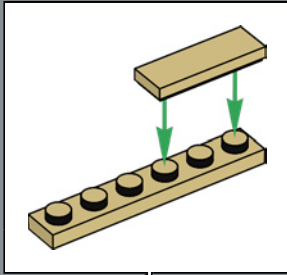

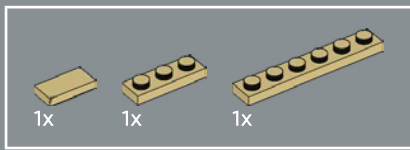

239

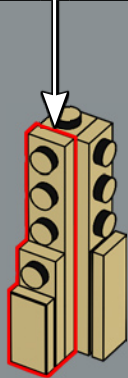
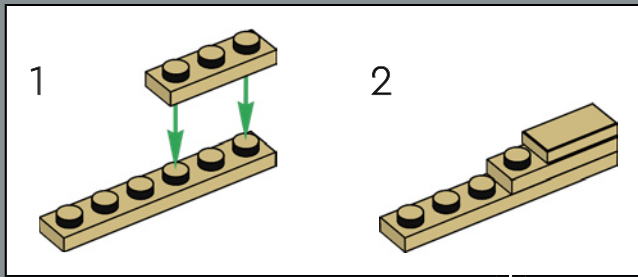

240

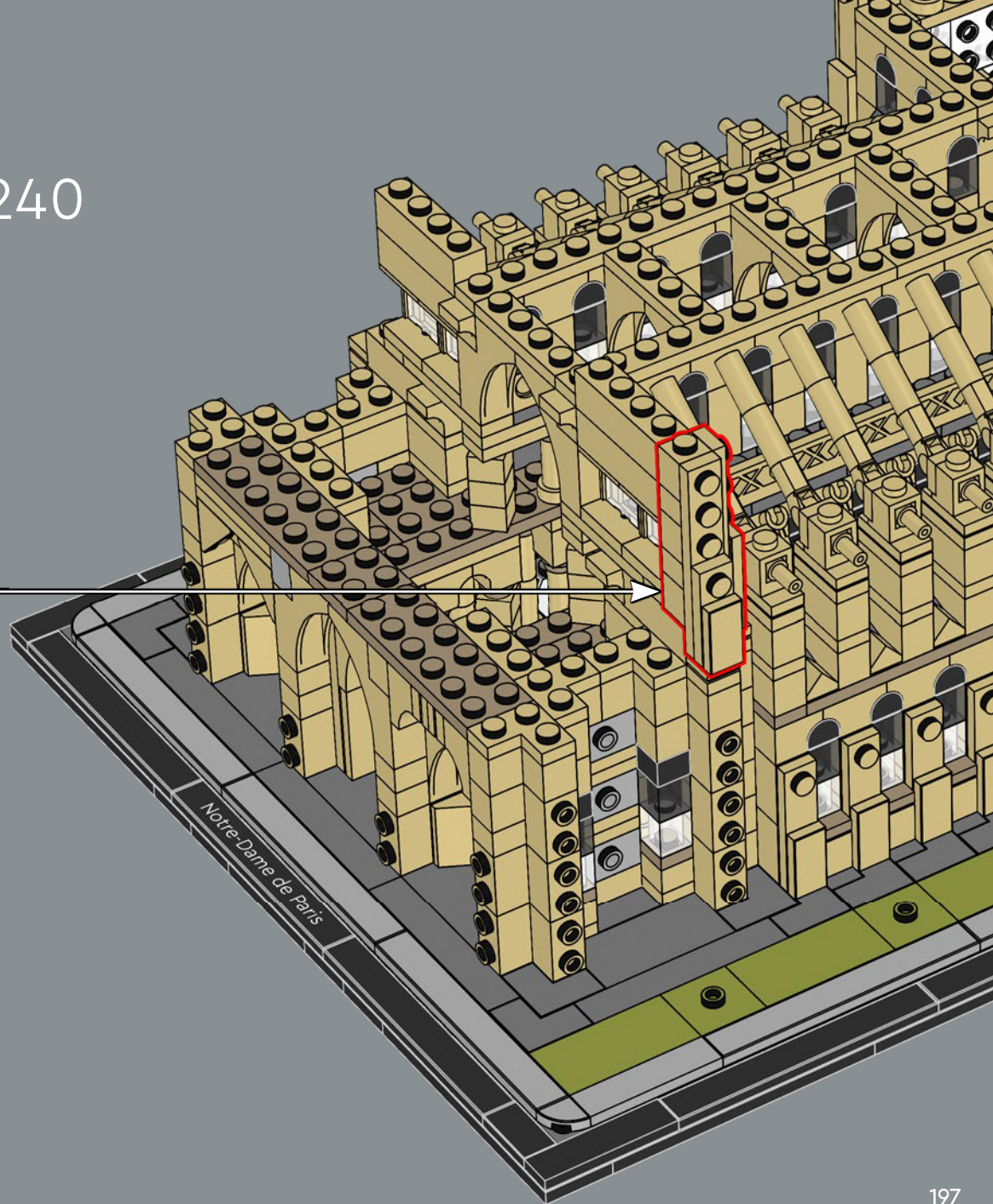

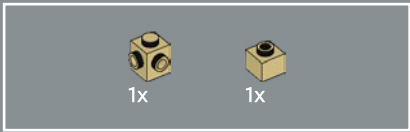

241

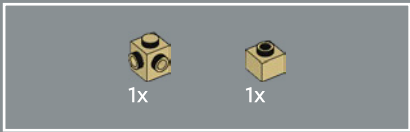
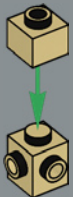

242



243

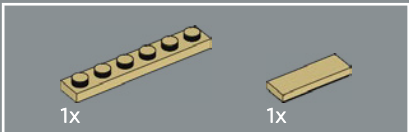

244

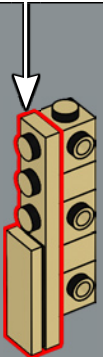
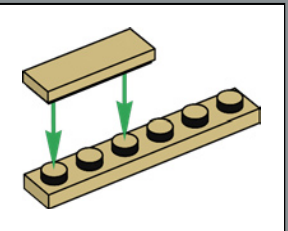

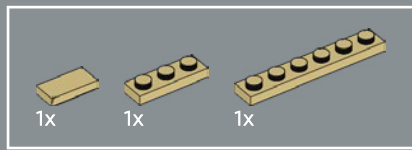

245

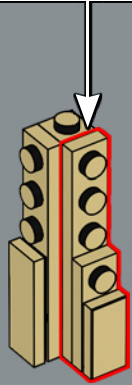
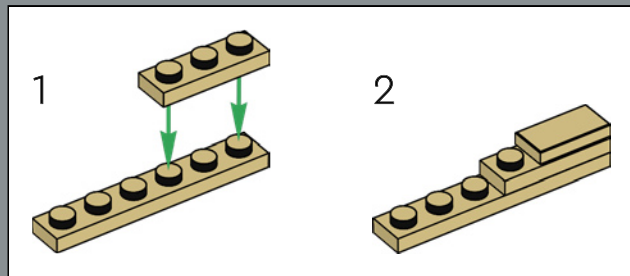

246

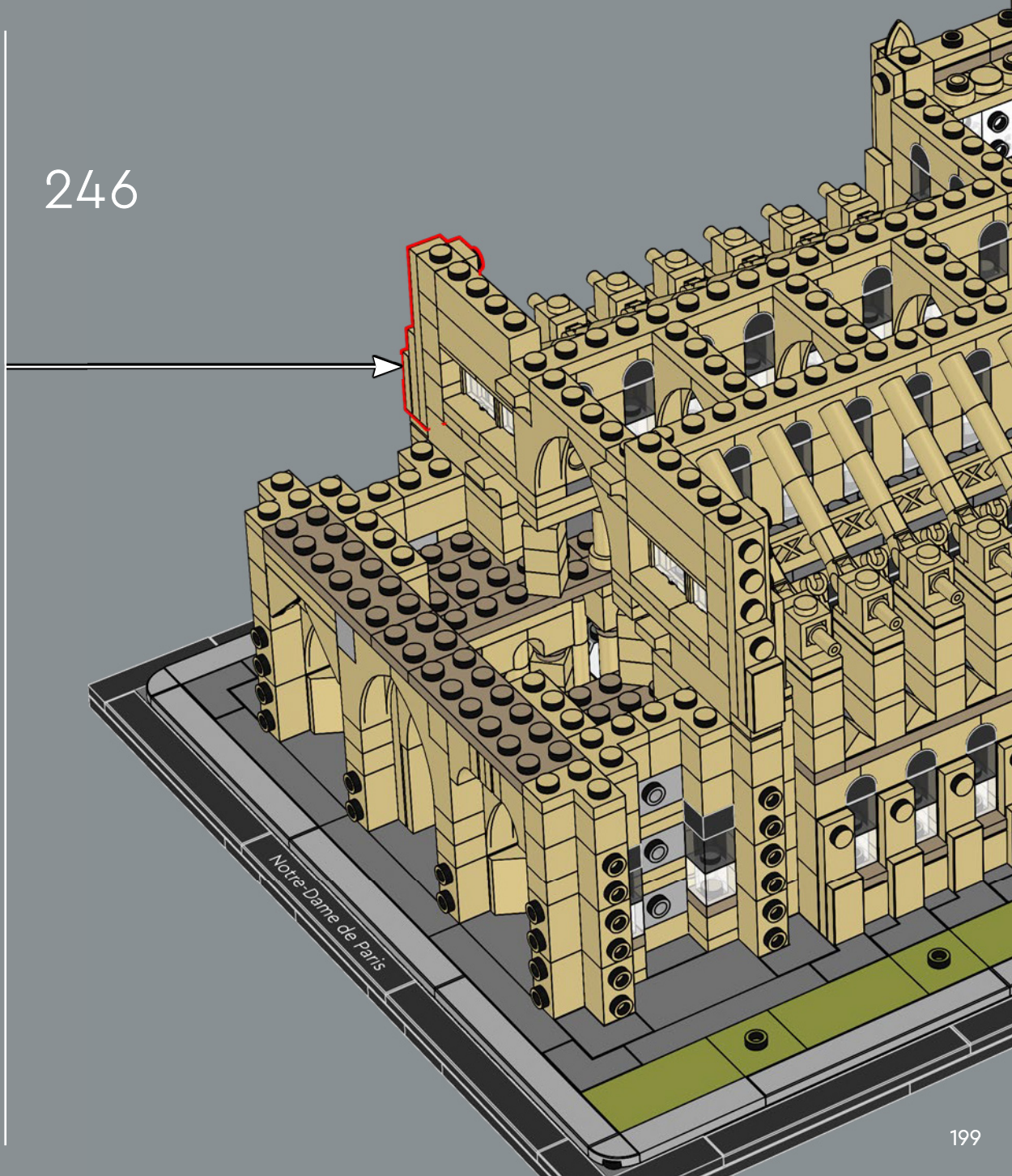



247

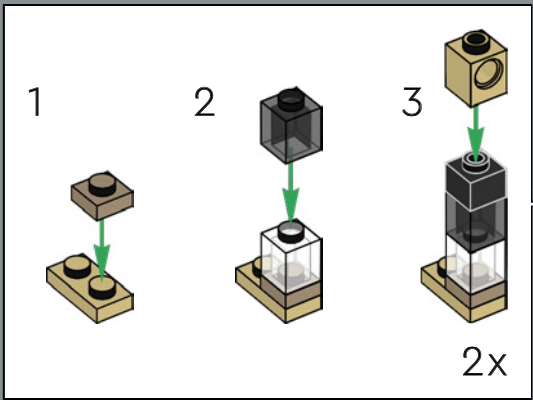



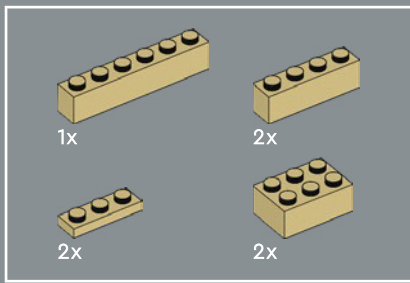

248

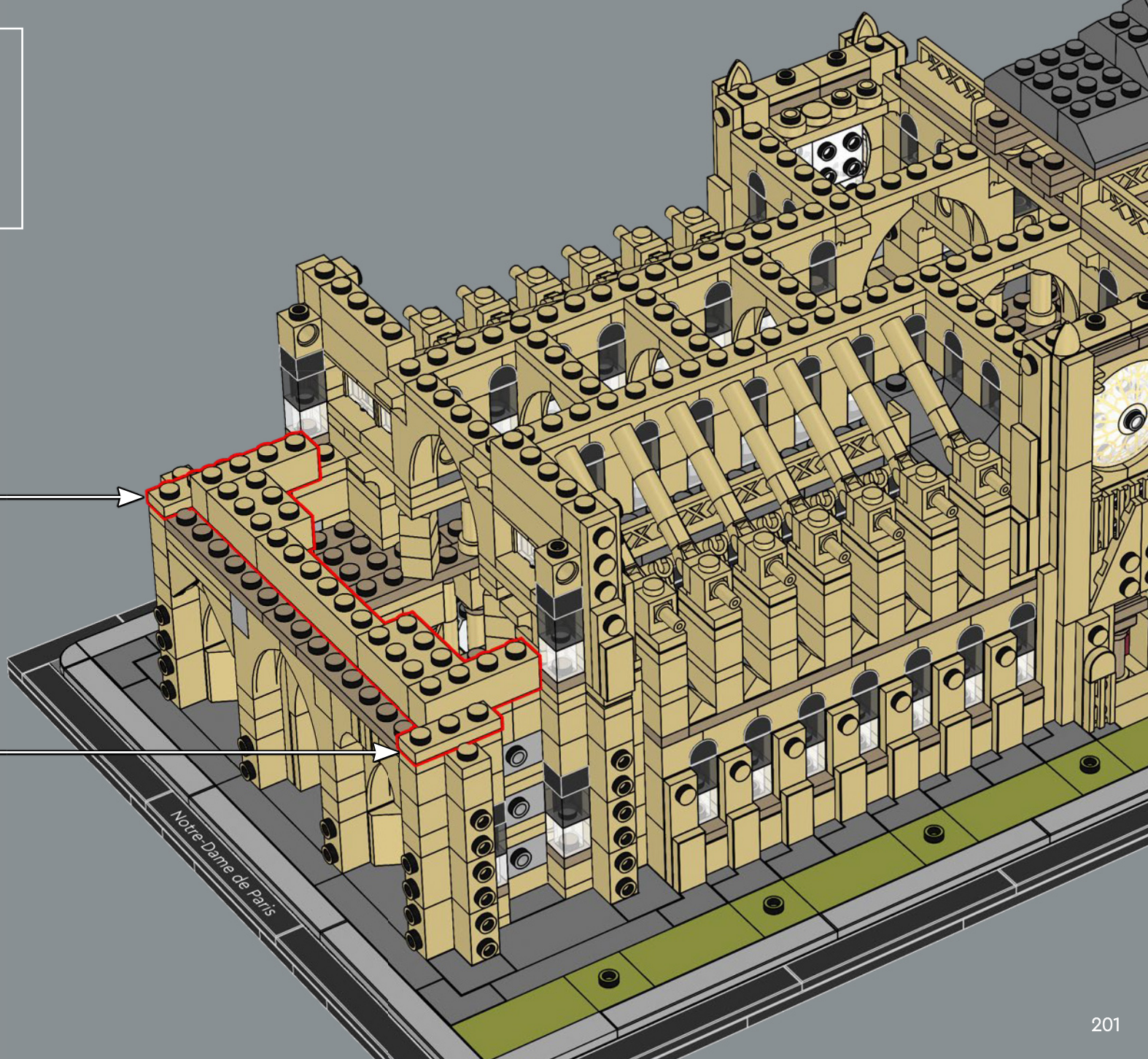
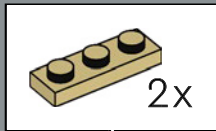

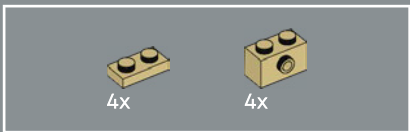

249

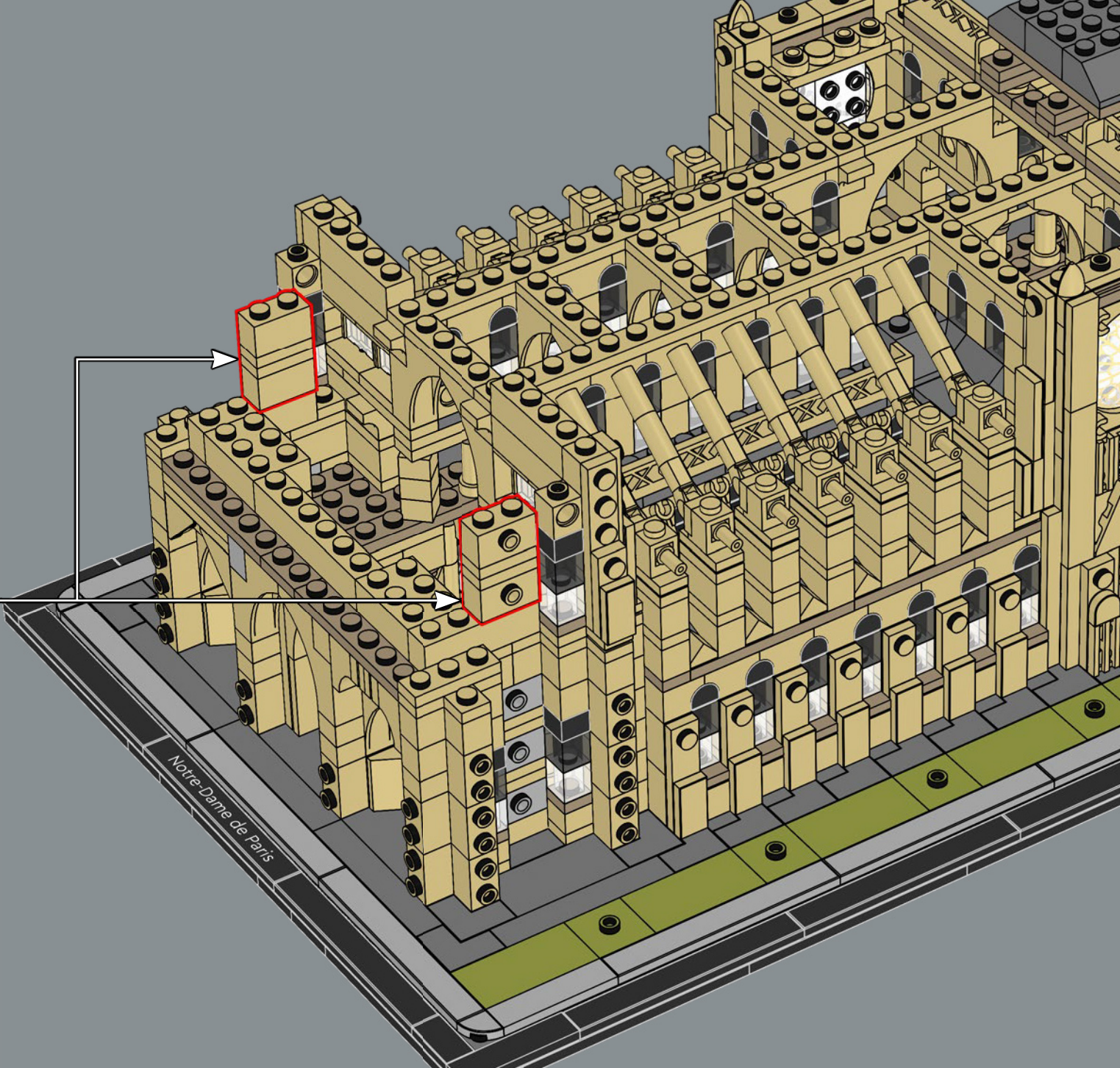
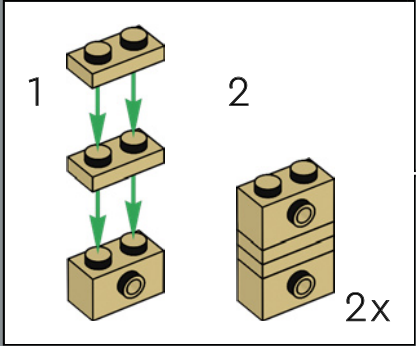

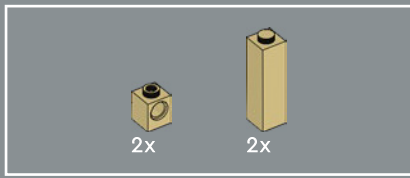

250

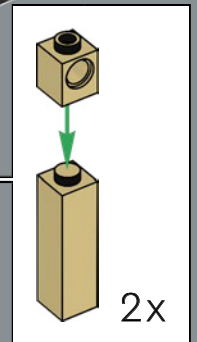
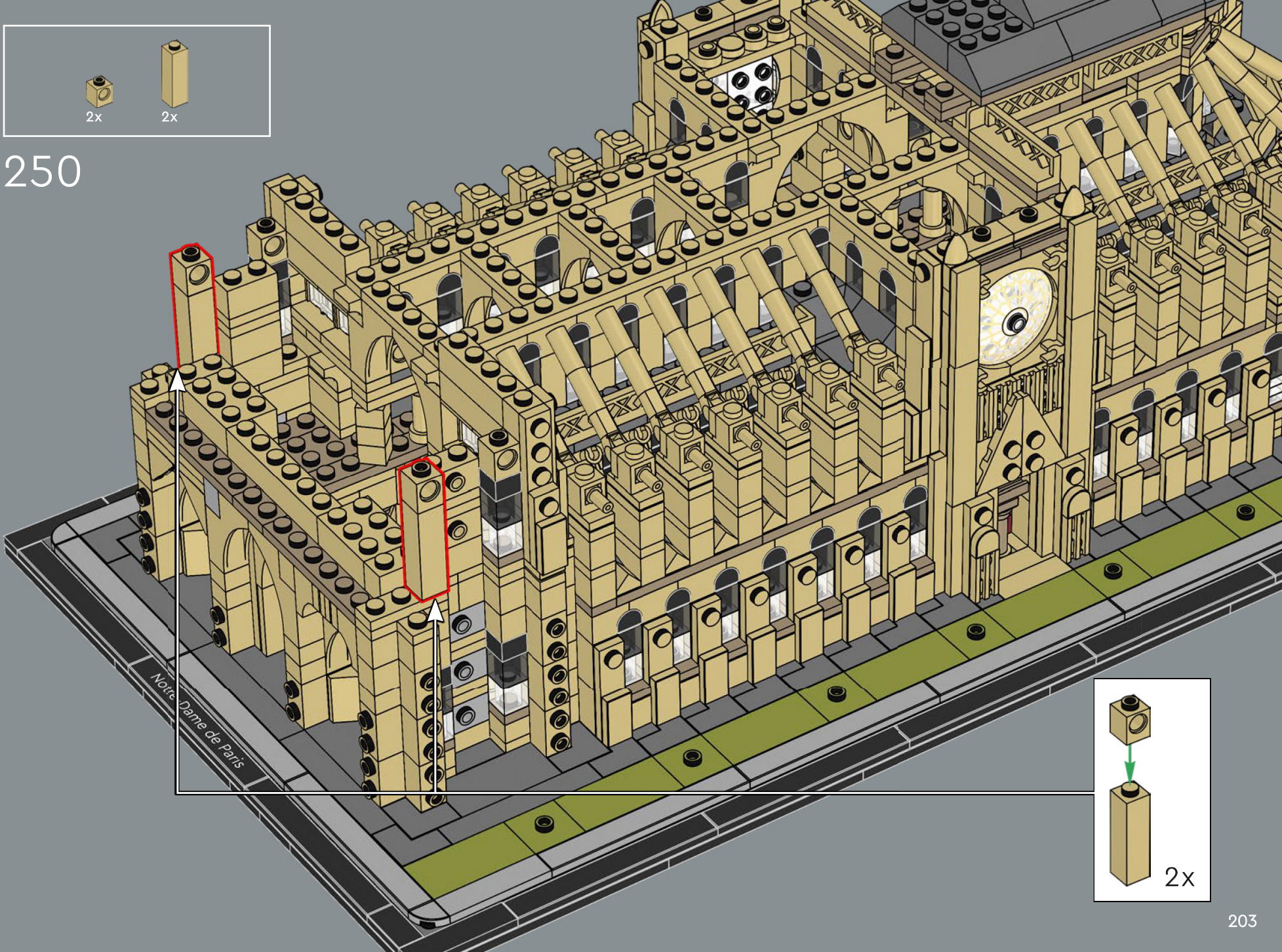

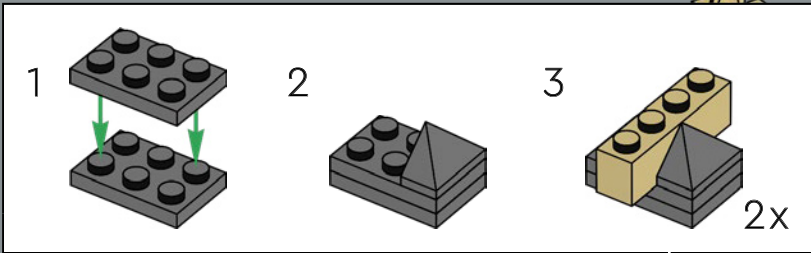
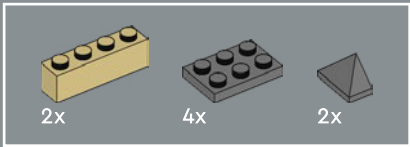

251

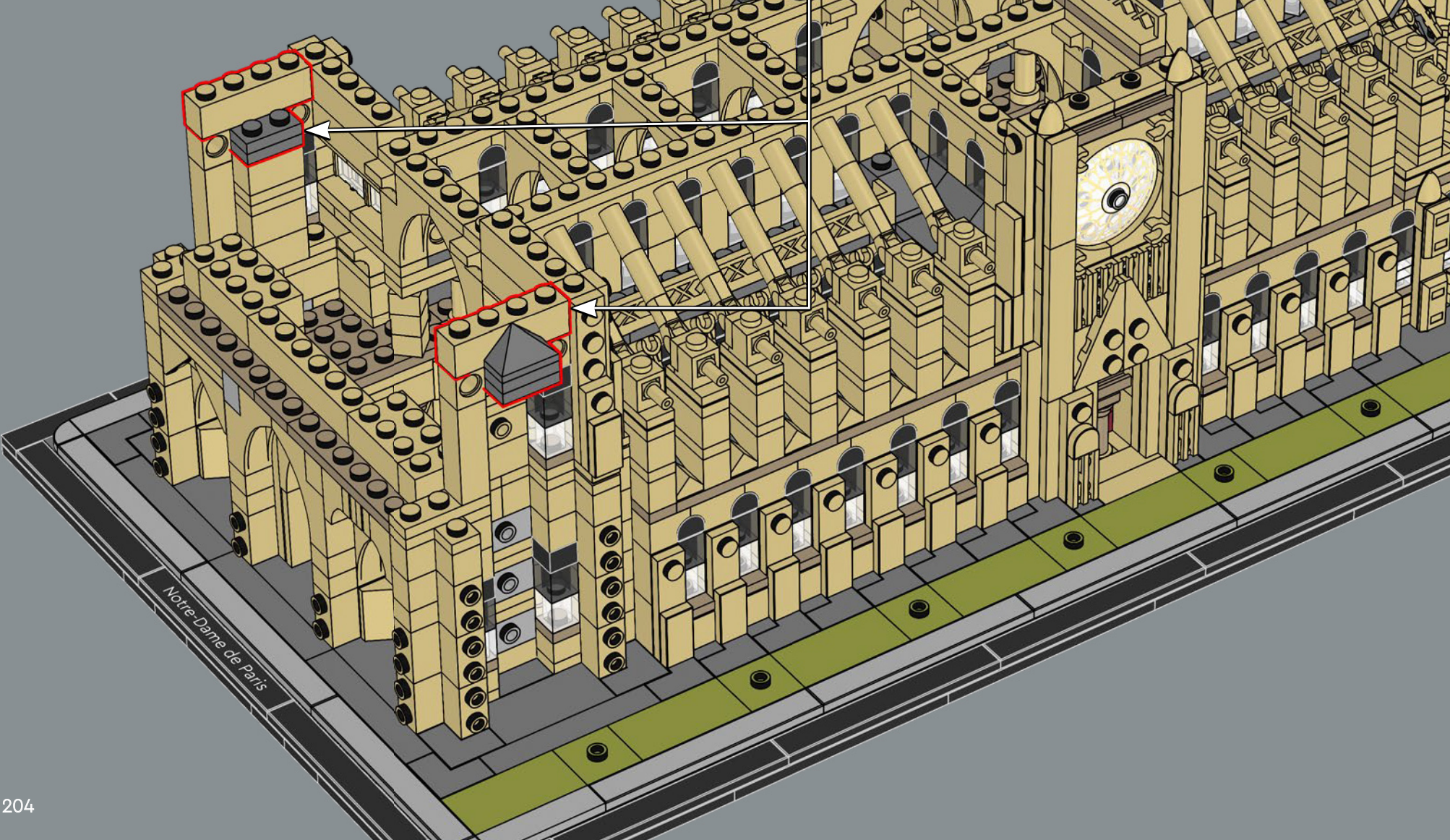

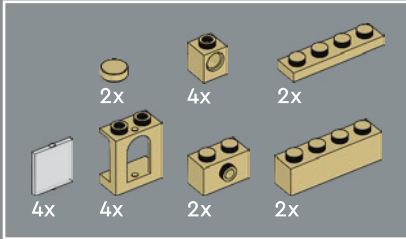
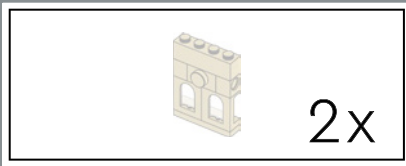

252

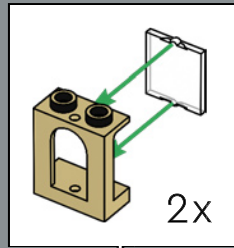

1

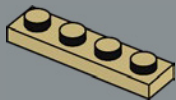

2

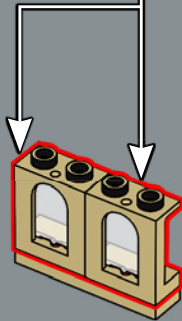

3

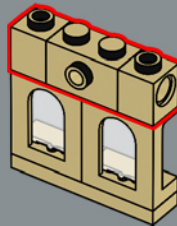

4

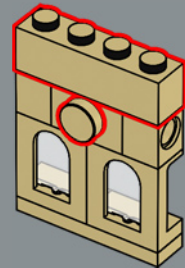

2x

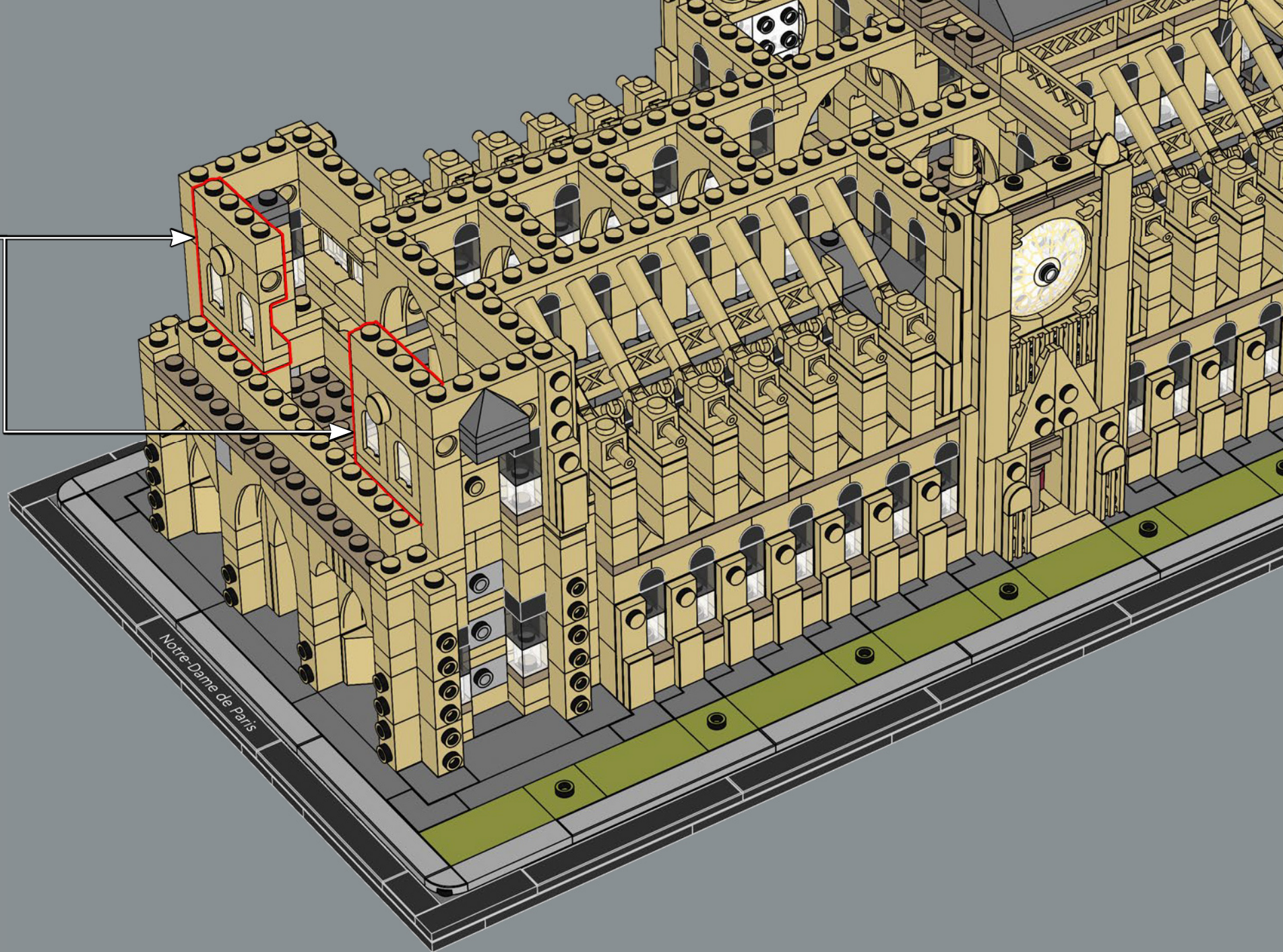

*Notre-Dame de Paris*

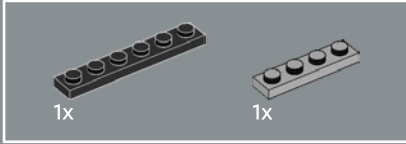
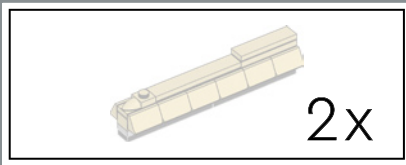

253

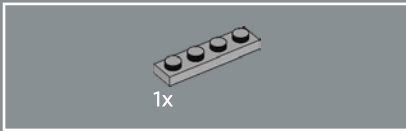
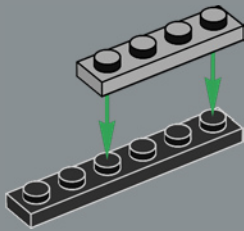

254

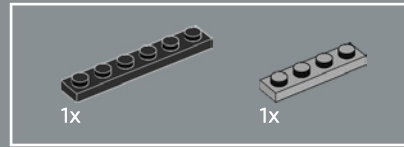
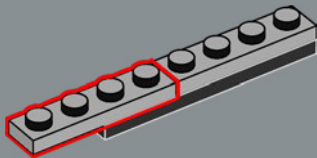

255

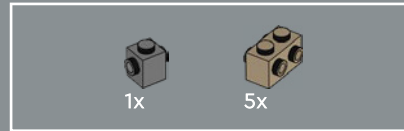
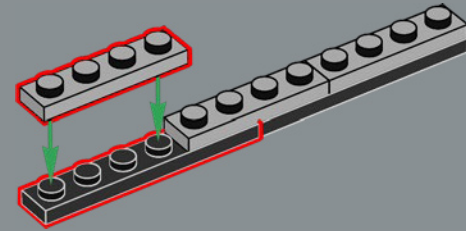

256

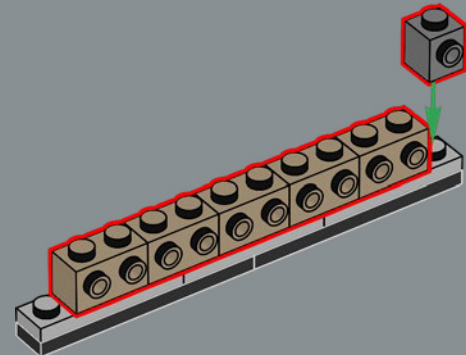

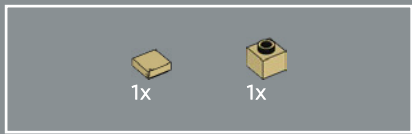

257

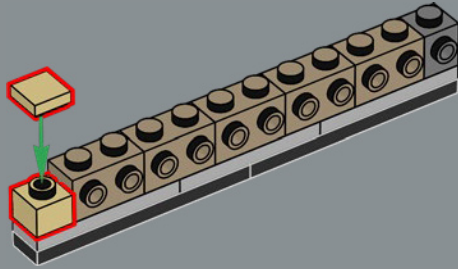

258

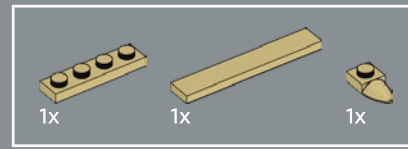
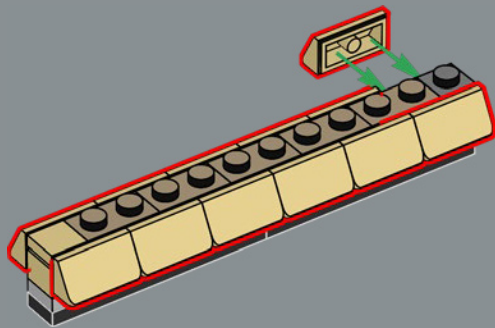

259

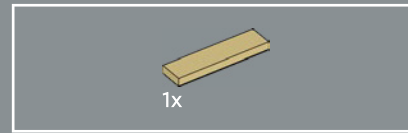
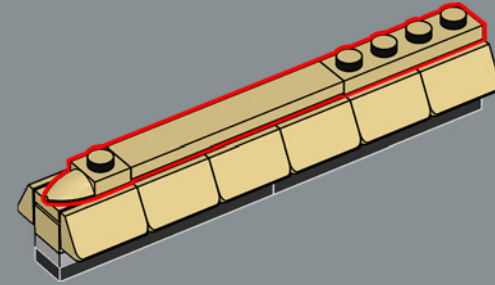

260

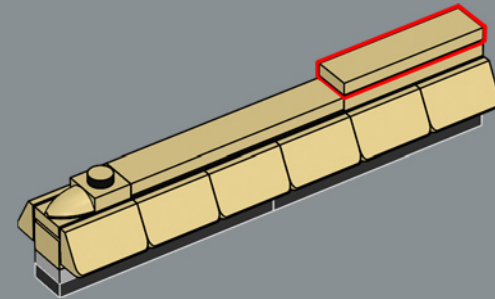

2x



261



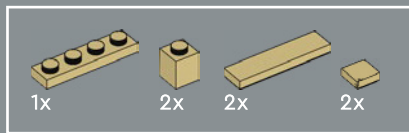

262

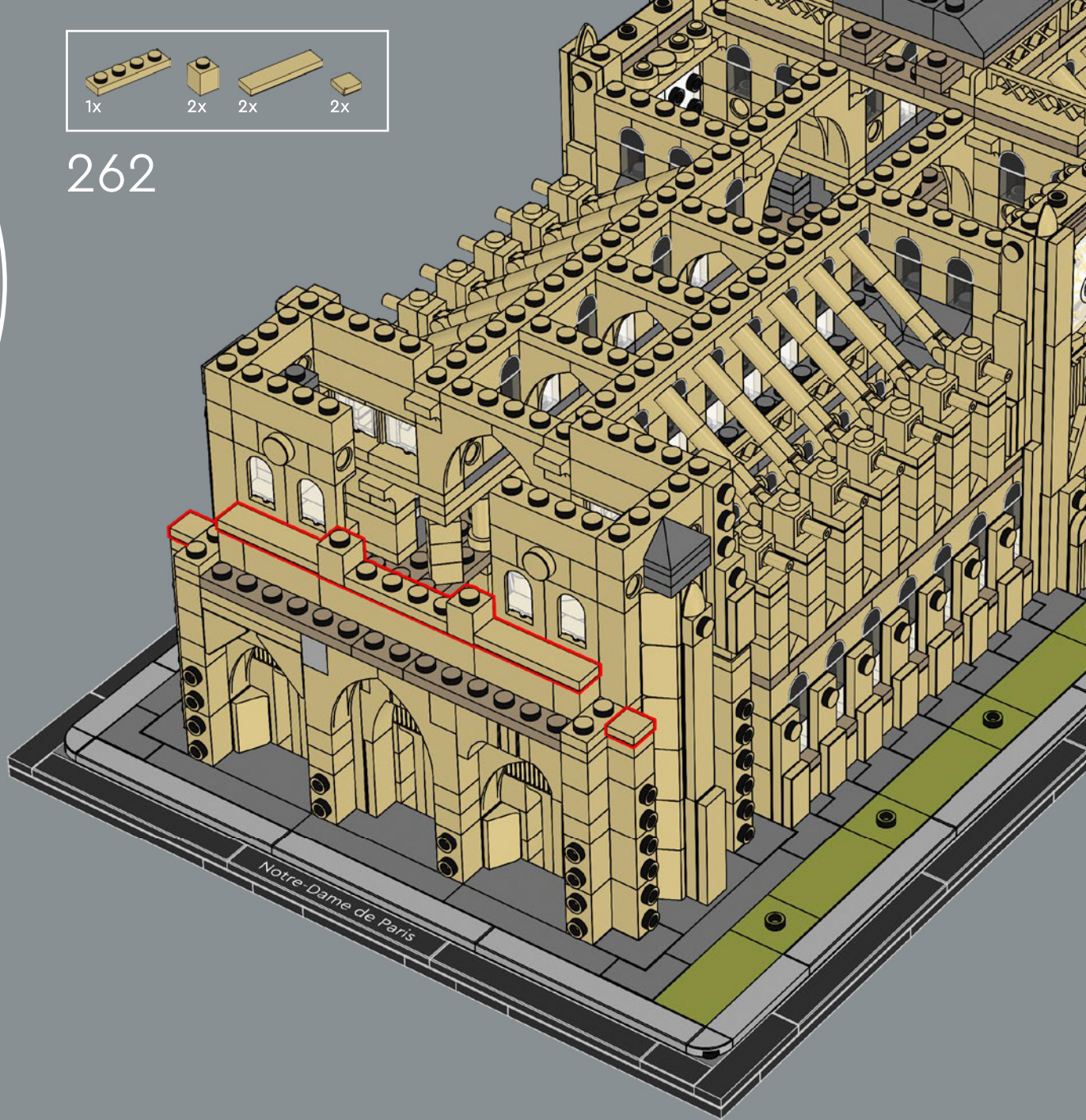



263



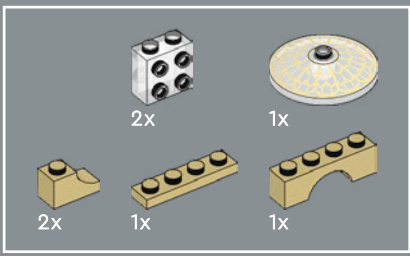

264

1

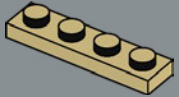

2

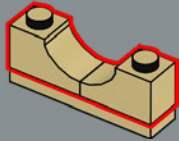

3

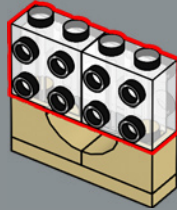

4

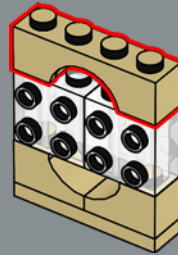

5



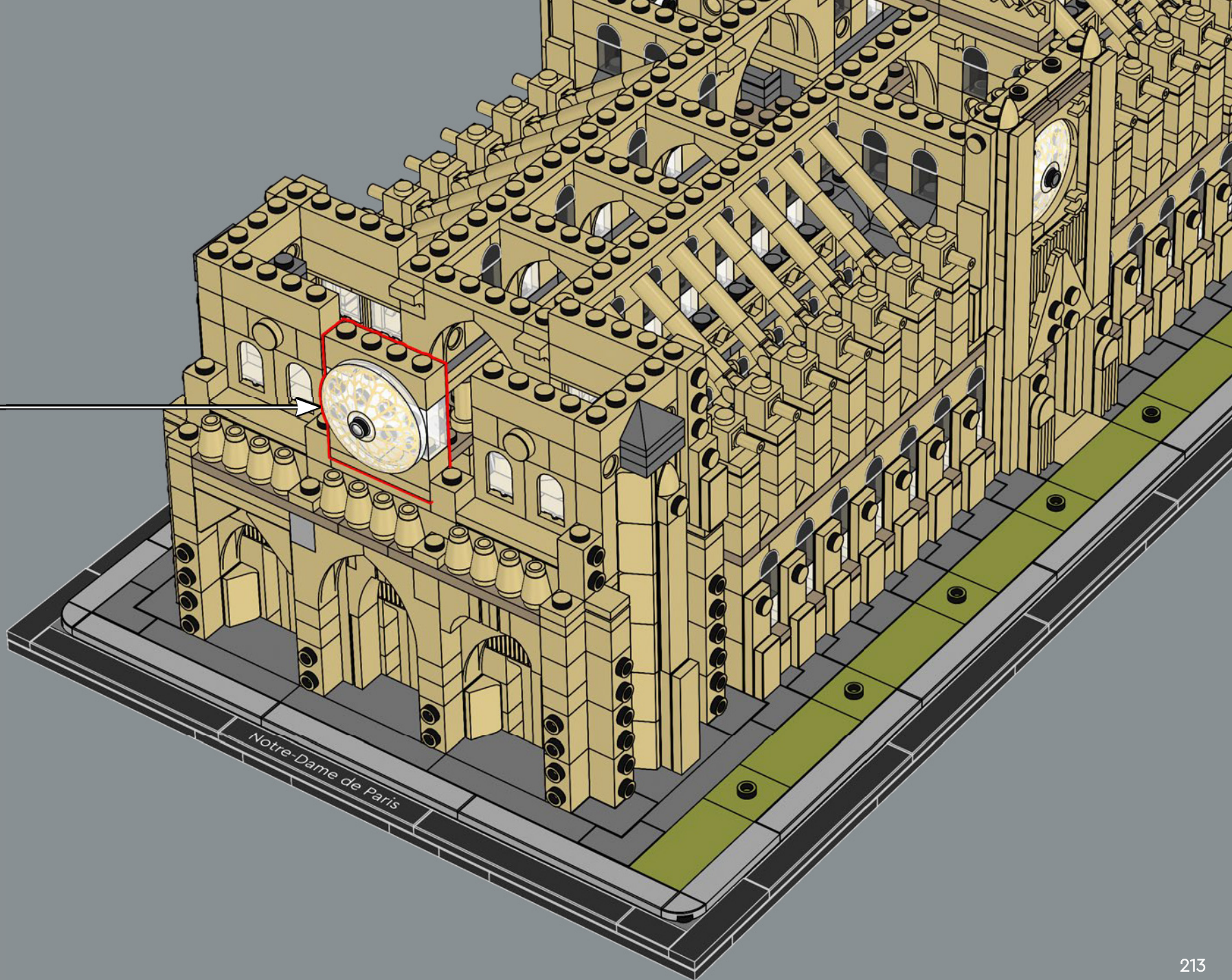

Notre-Dame de Paris

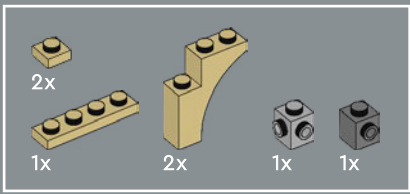

# 265

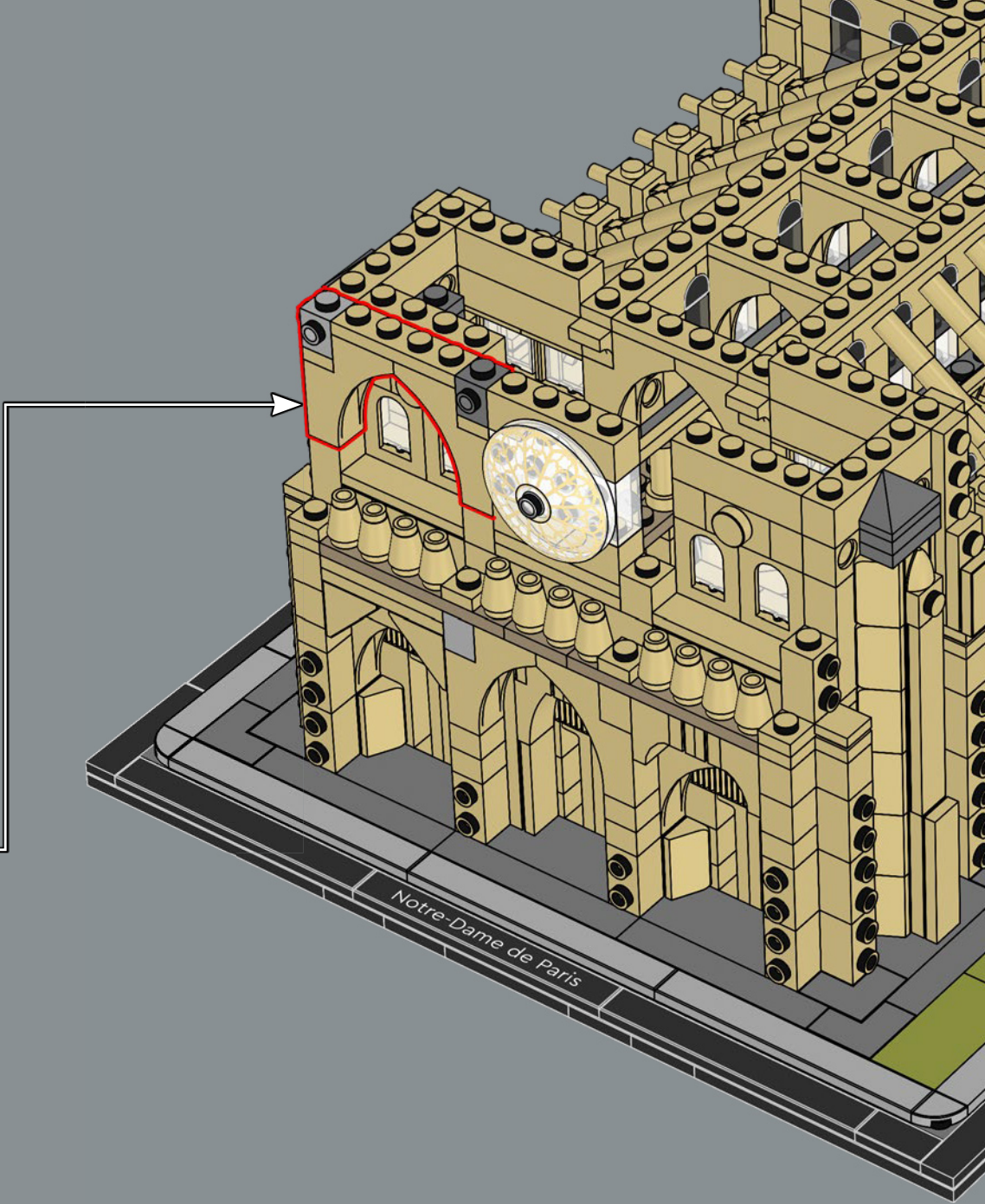
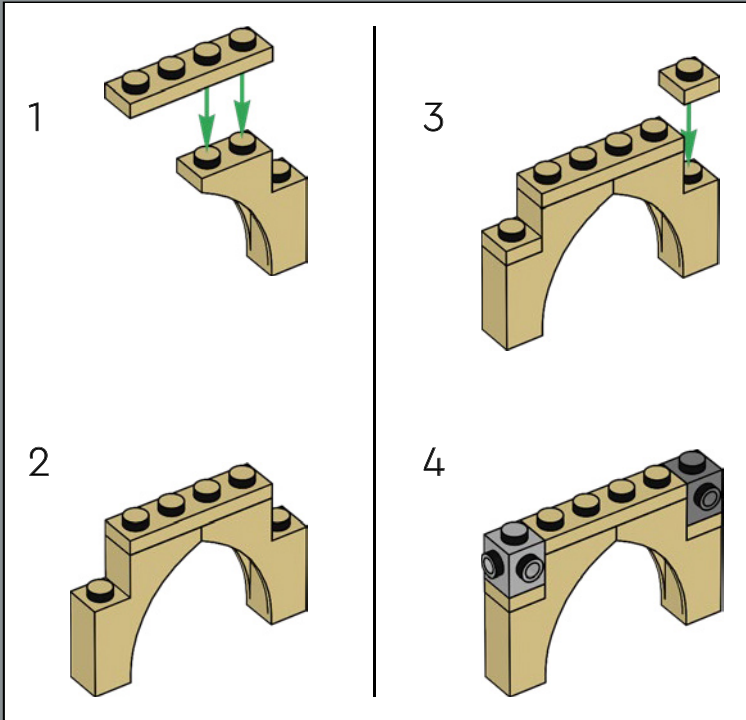

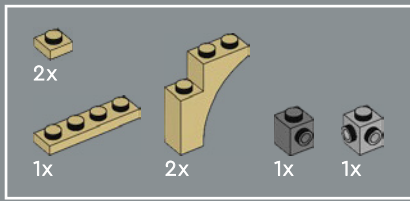

266

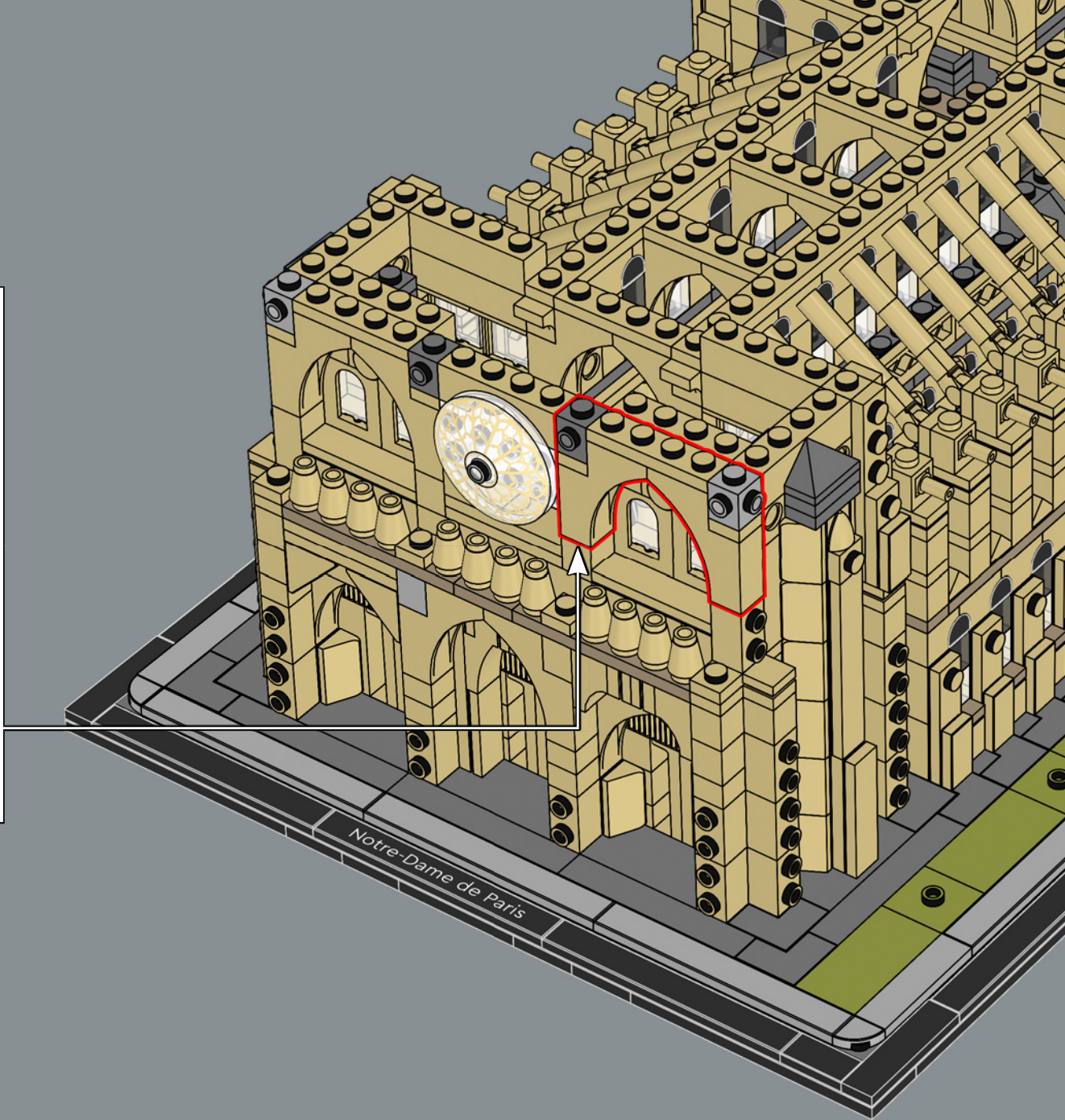
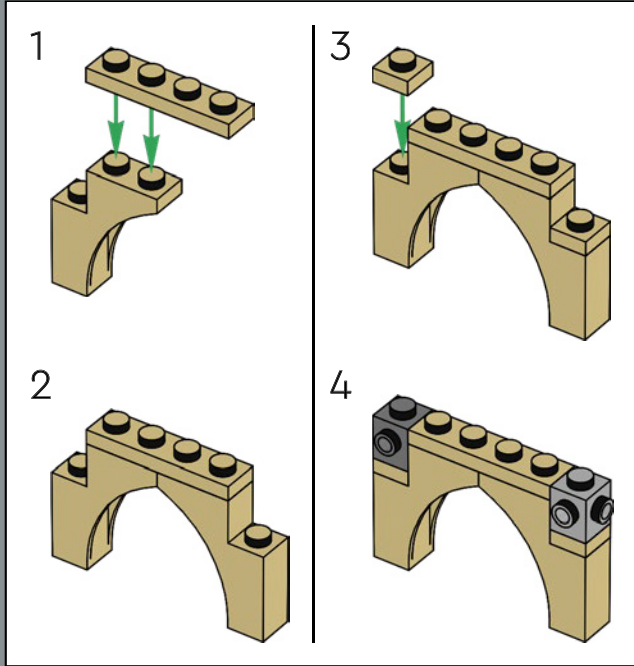

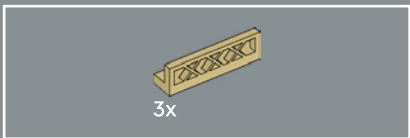

267

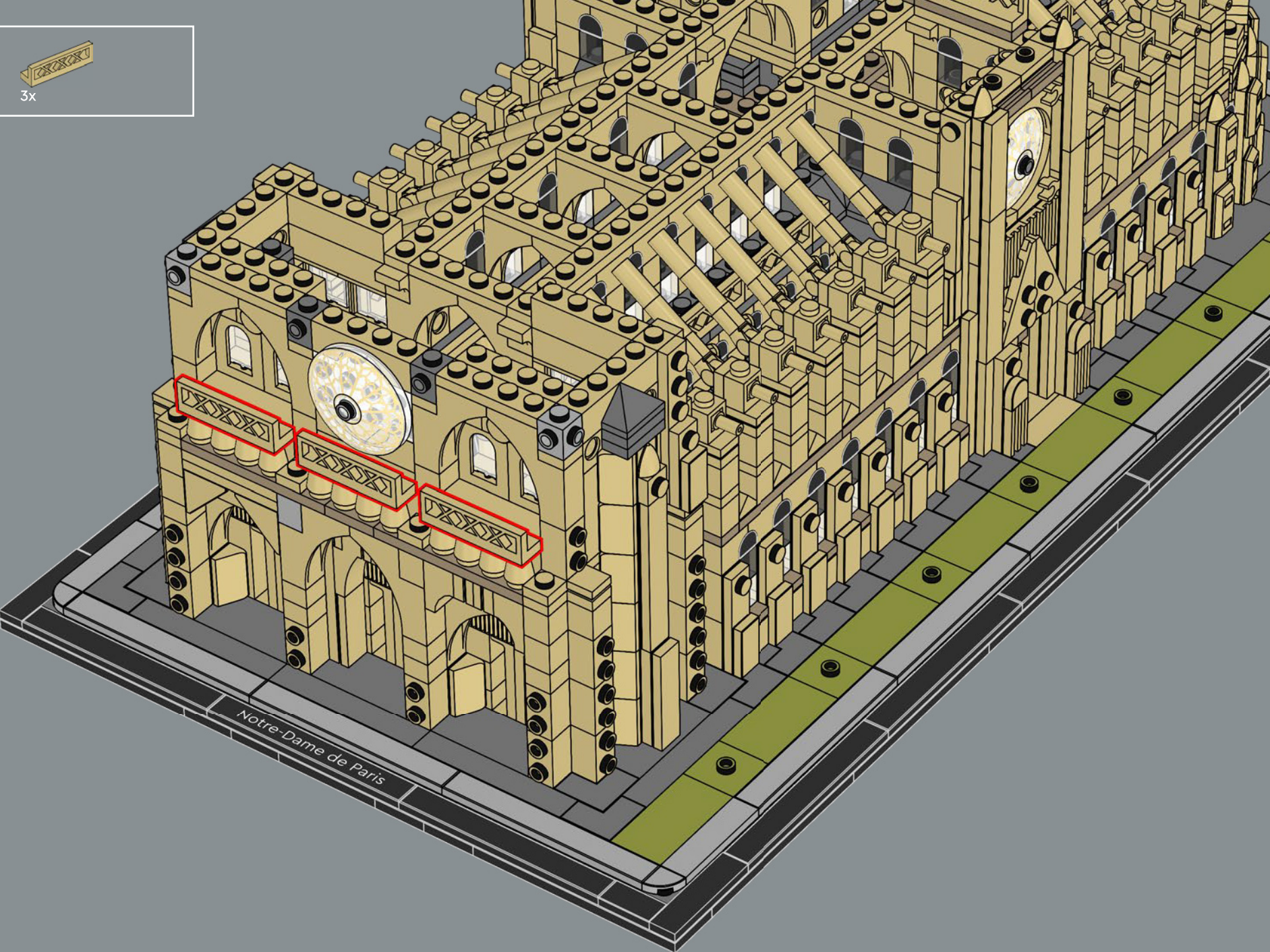



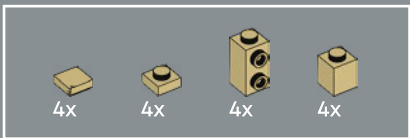

268

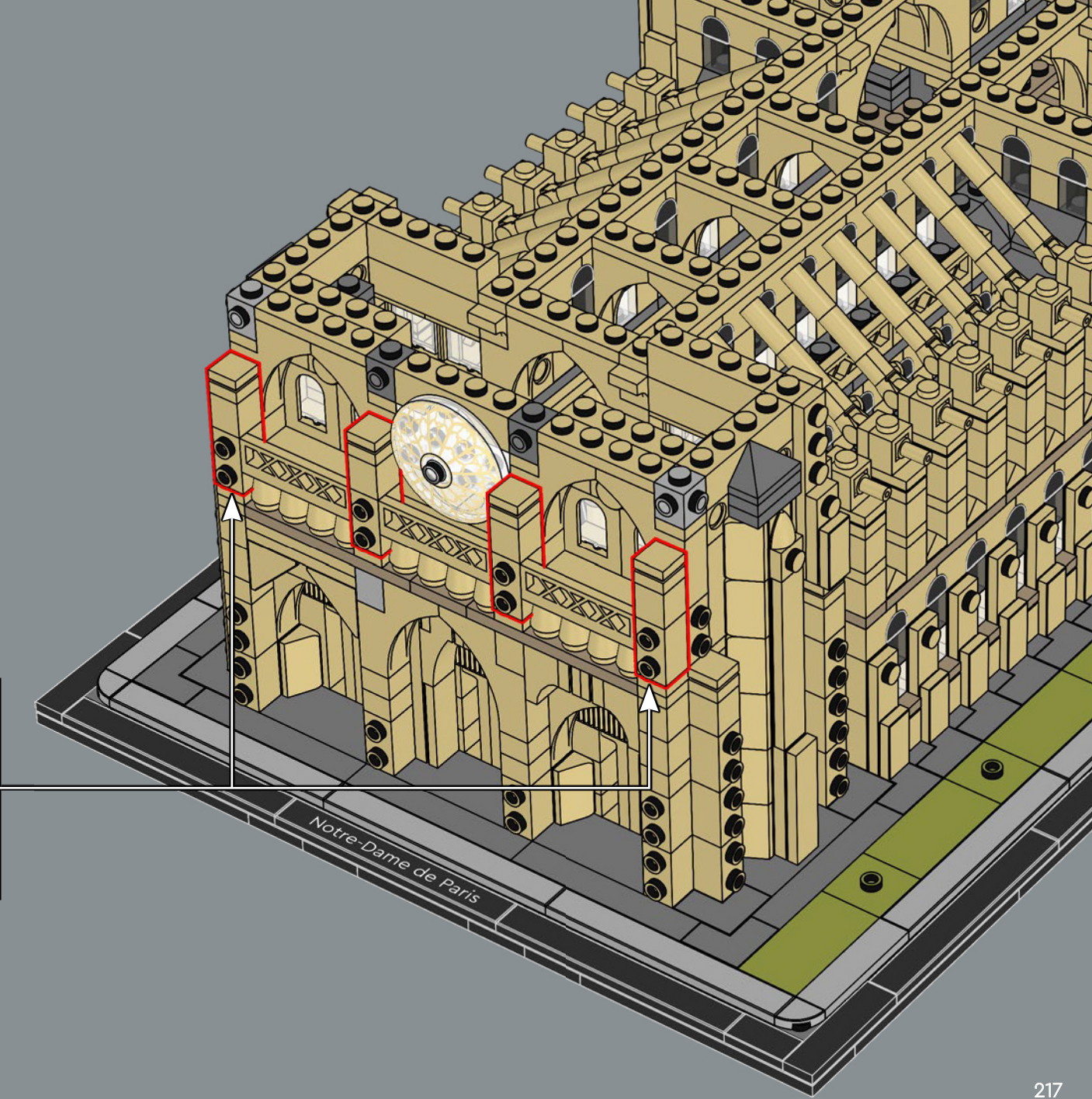
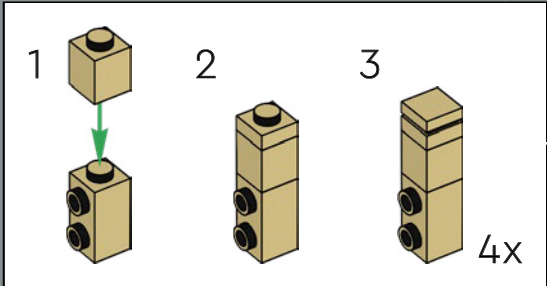

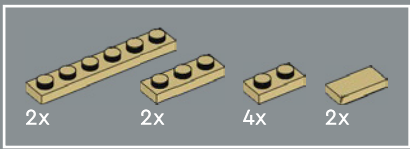

269

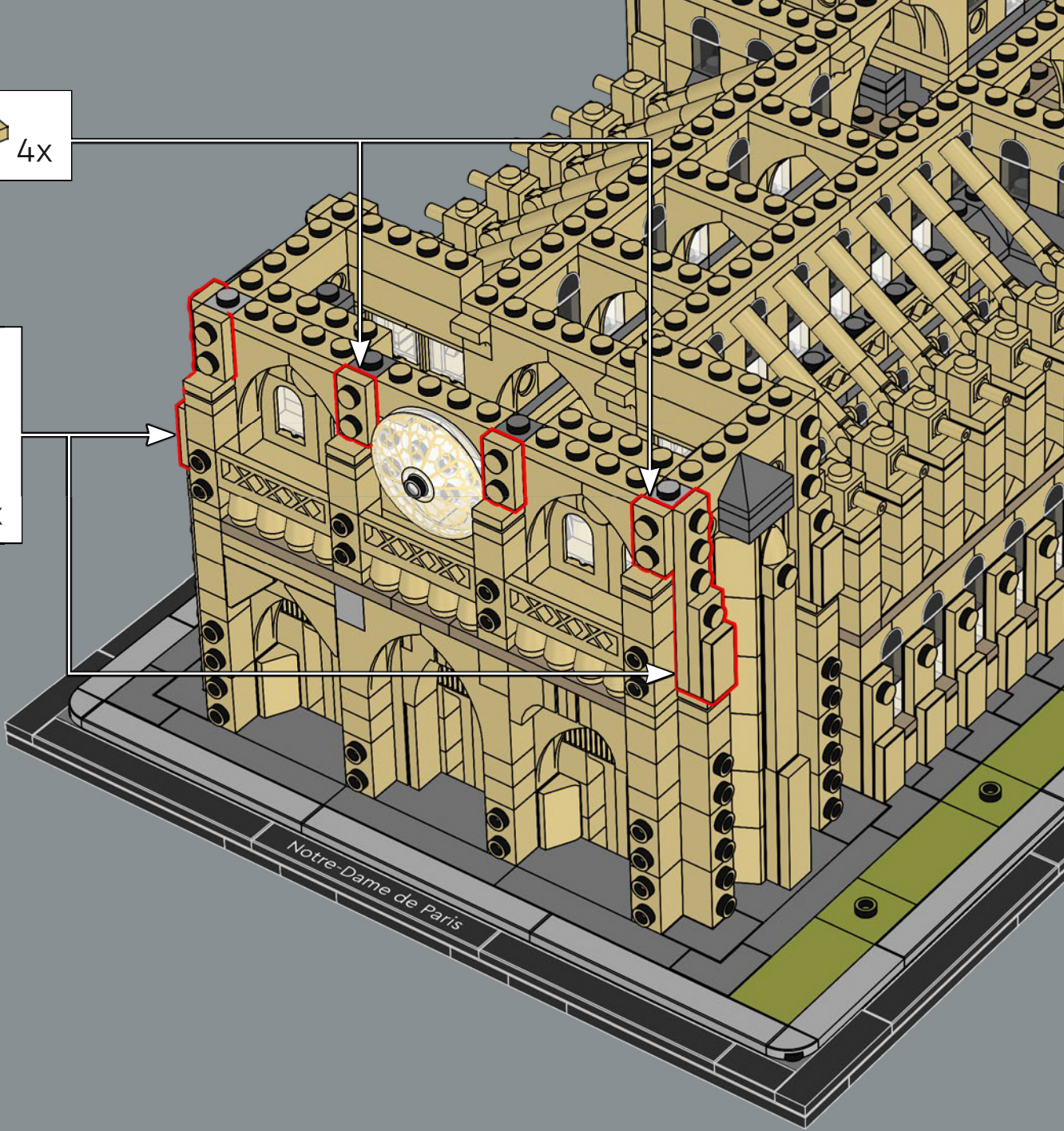
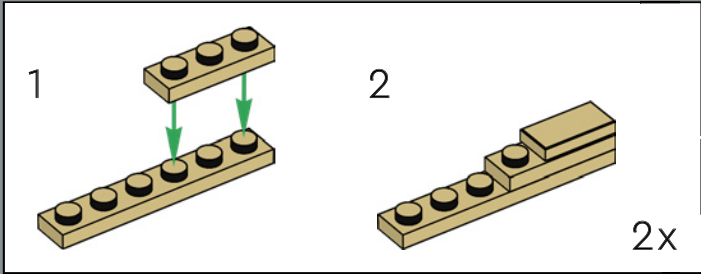
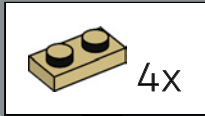

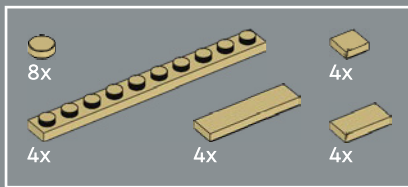

1220: Drei Portale, die von der Königsgalerie überdacht werden, heißen die Besucher im majestätischen Eingang zur Kathedrale willkommen. Die 28 riesigen Statuen werden durch 20 LEGO® Kegel und runde Elemente dargestellt.

270

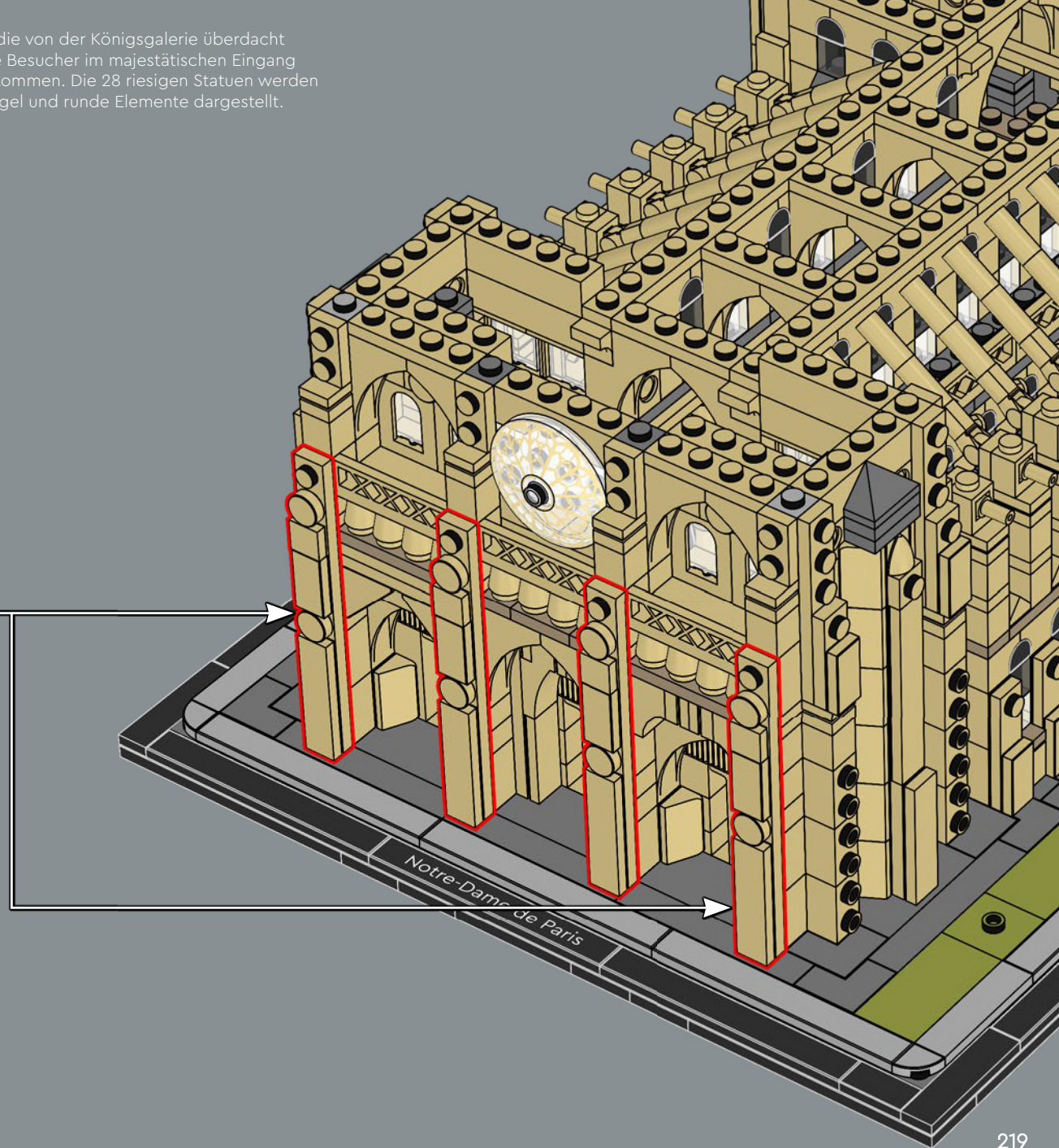
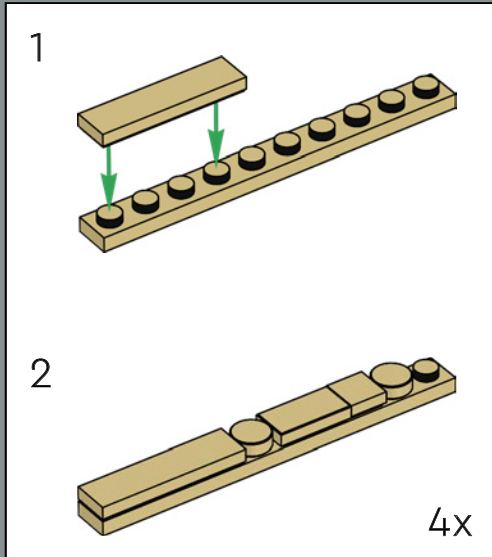

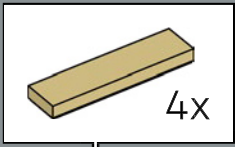
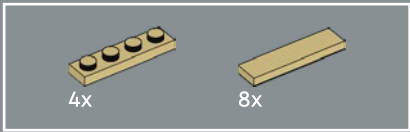

271

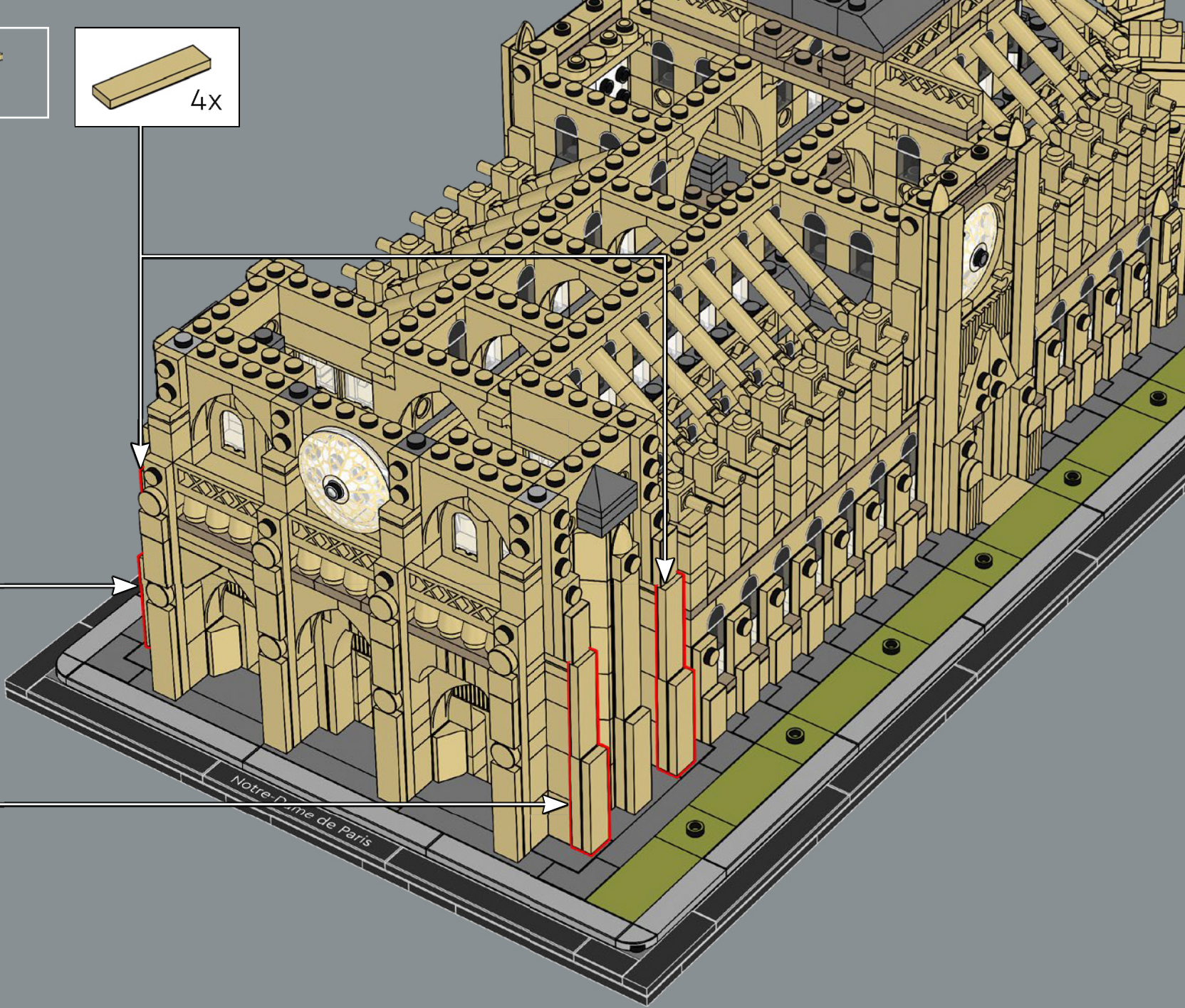
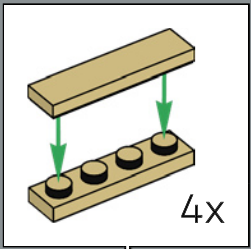

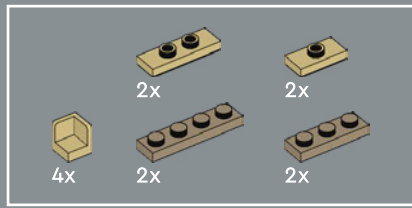

272

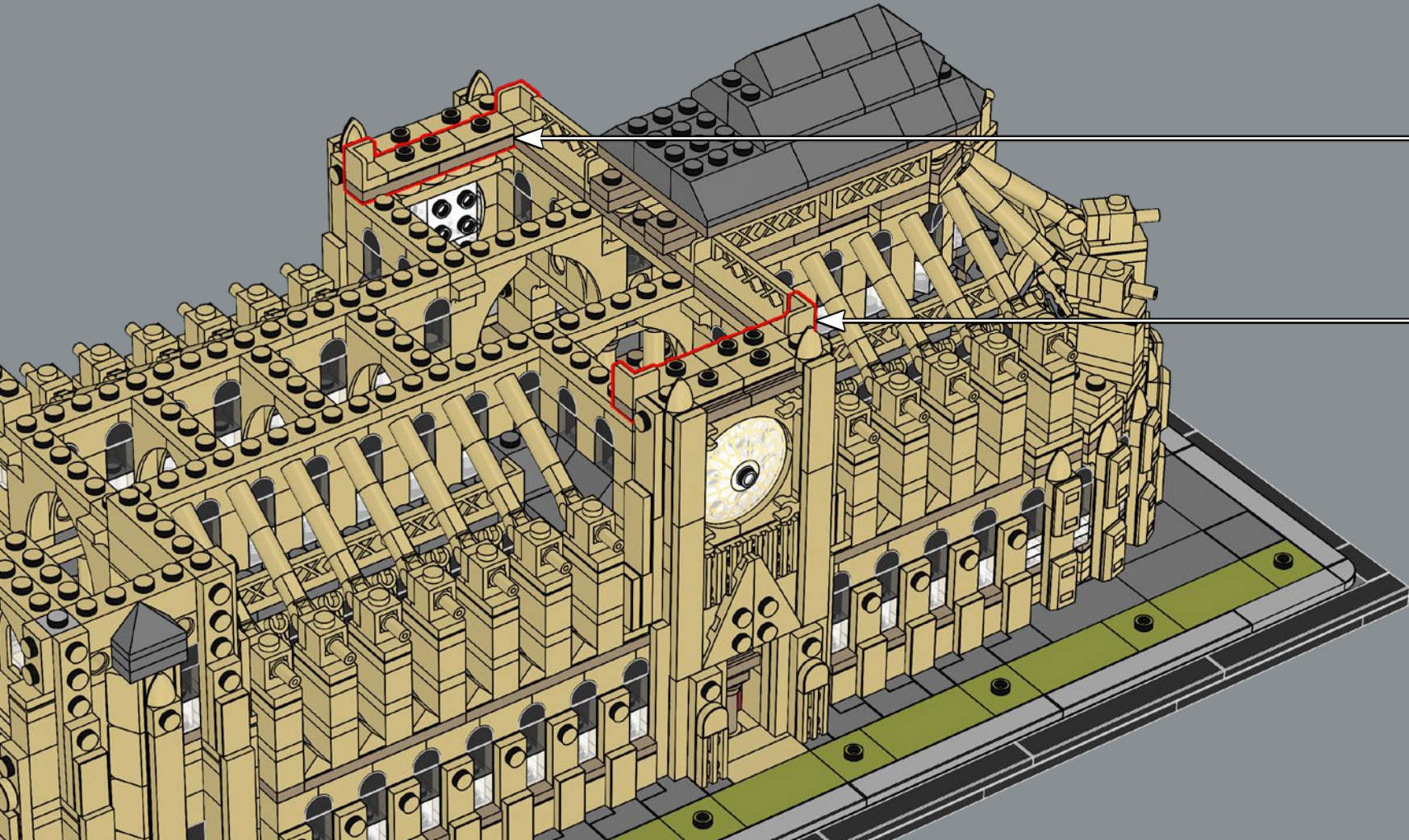
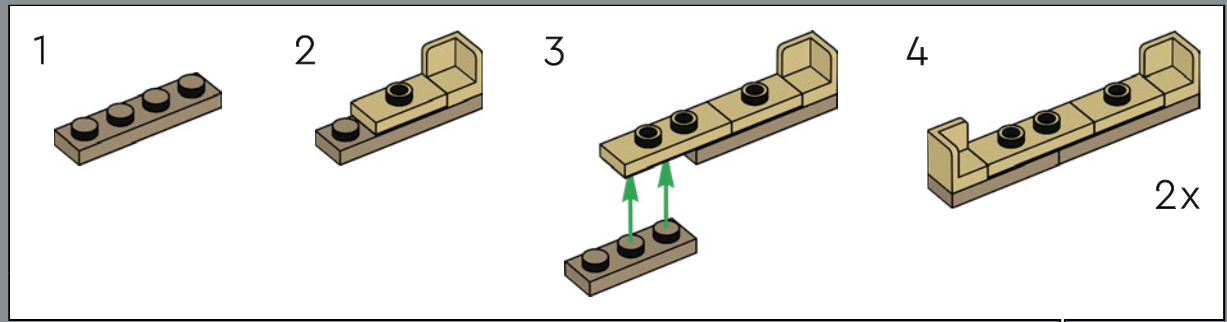

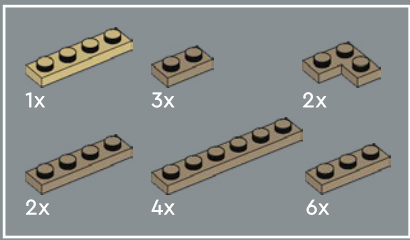

273

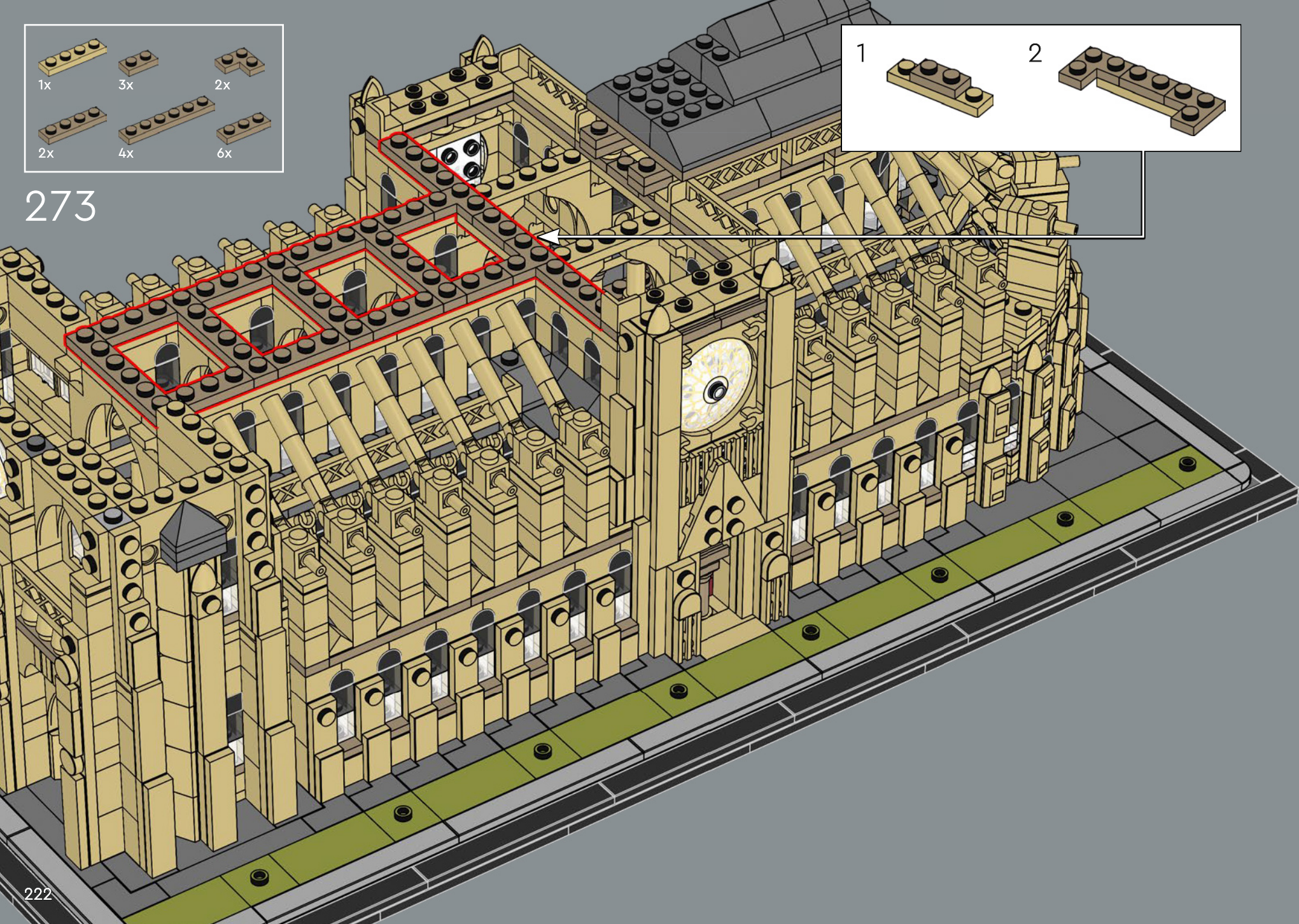
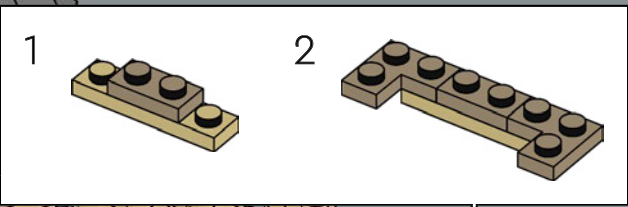

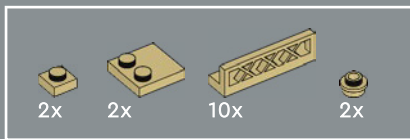

274

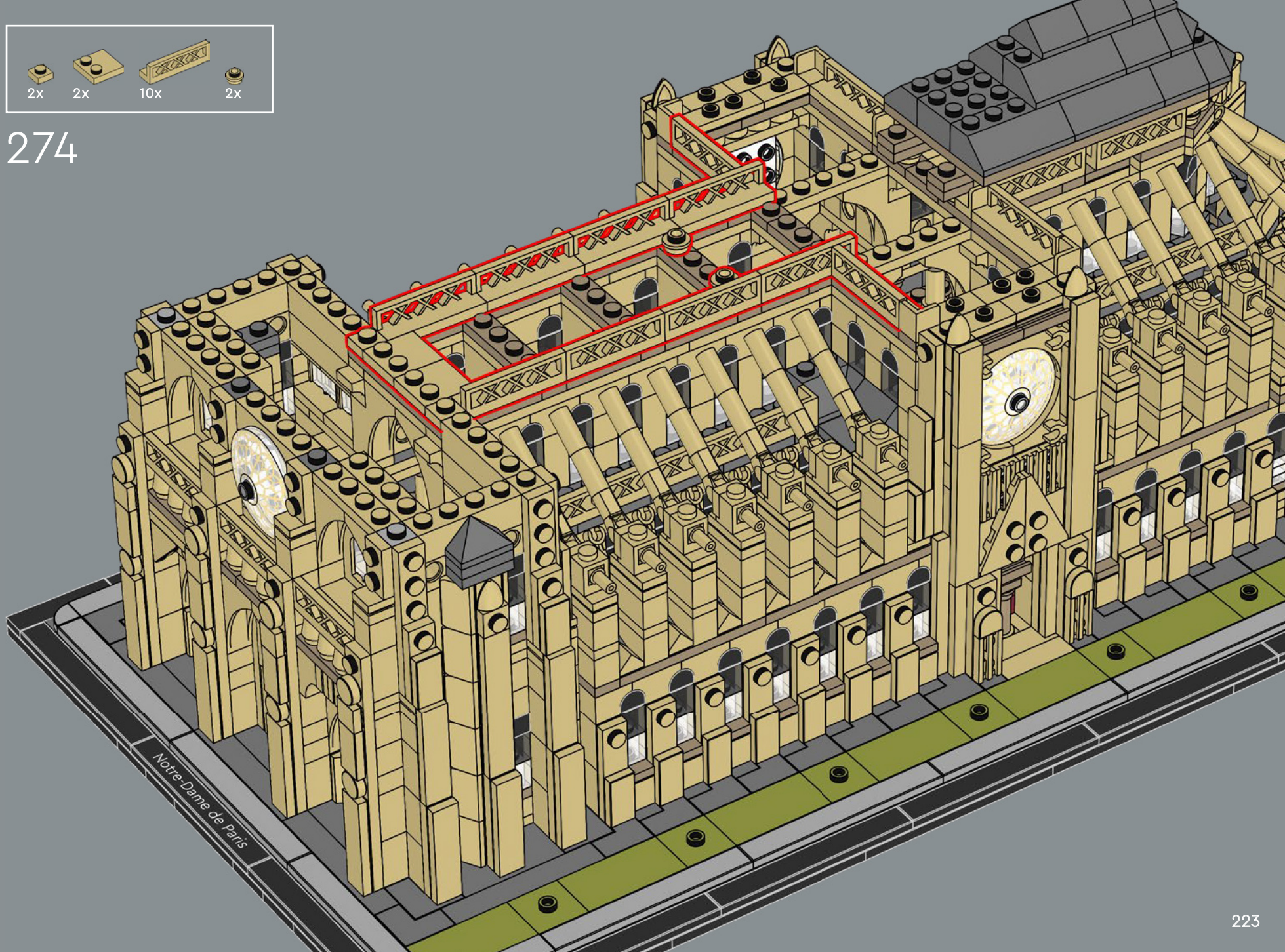



## DIE VERWANDLUNG GEHT WEITER

☞ Im Jahr 1245 waren alle Türme fertig. Beim Bauen der Türme kannst du das Innenleben des Glockenturms sowie den Oberbau erkunden, der die legendären Glocken trägt. Im Laufe der folgenden fünf Jahrhunderte kam es zu zahlreichen Abnutzungserscheinungen. Neue Generationen von Architekten waren für Modifikationen, Reparaturen und Anbauten verantwortlich. So wurde zum Beispiel ein mit Blei verkleideter Holzturm über der Vierung errichtet. Im Jahr 1300 wurden Kapellen am Rand des Chors hinzugefügt.





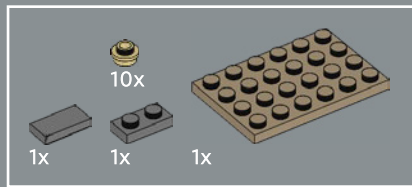

275

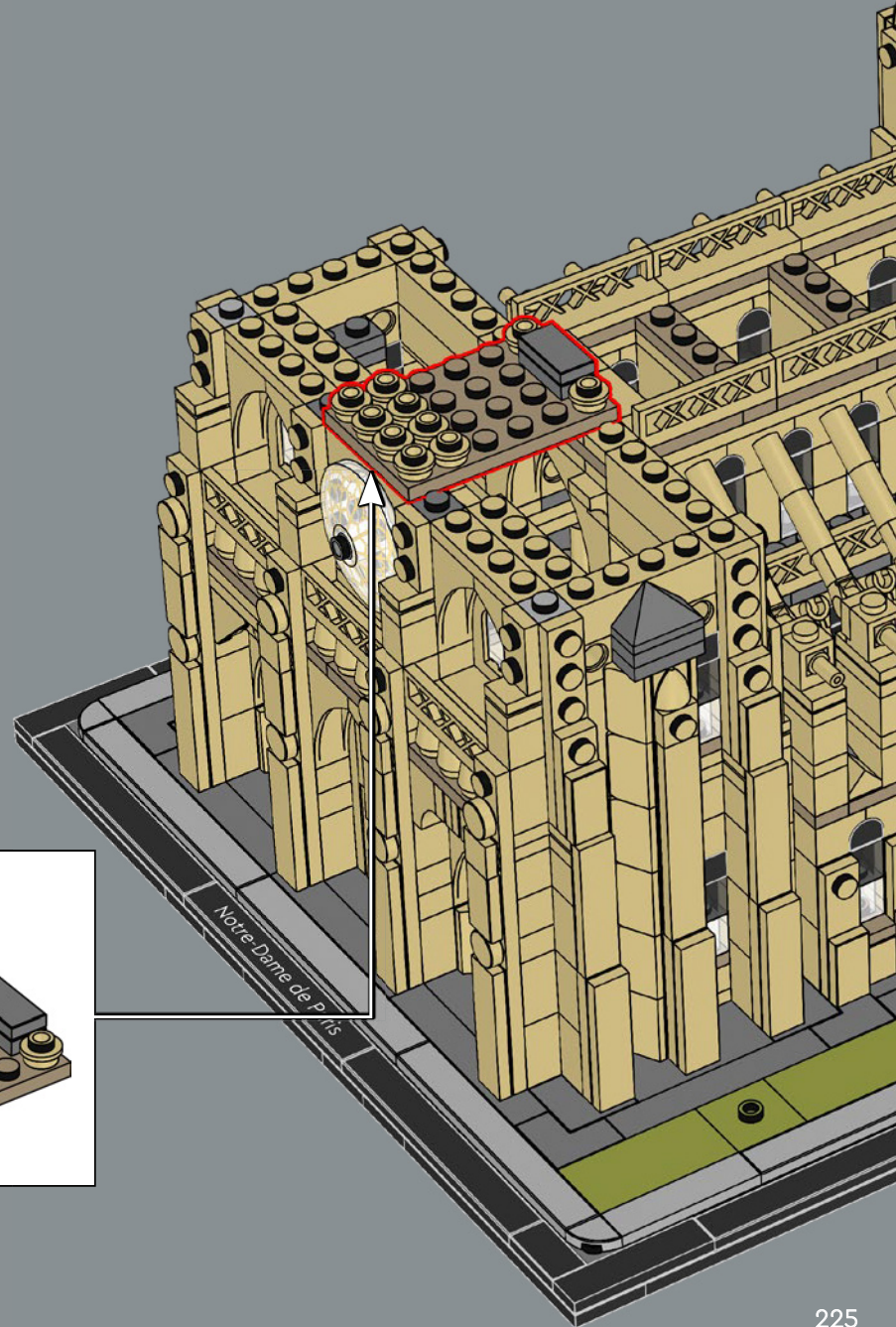
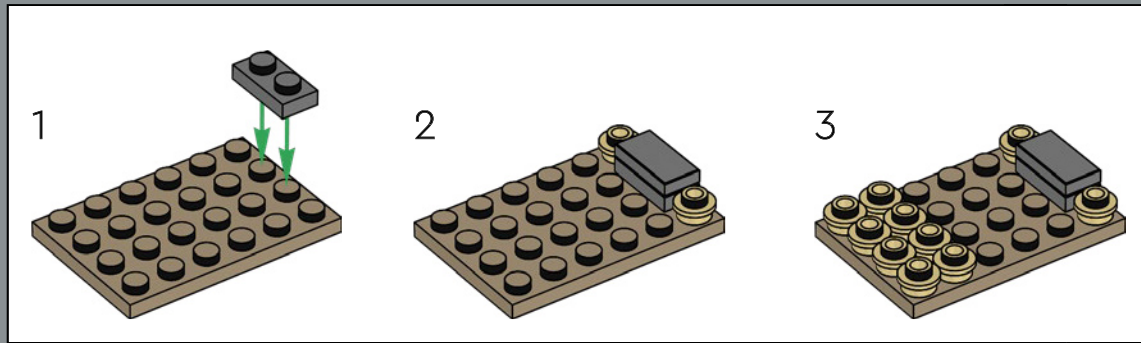

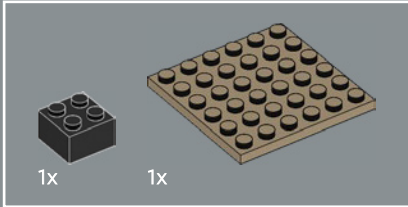
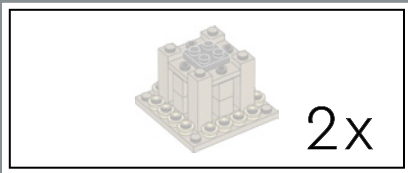

276

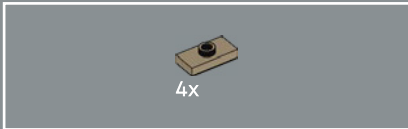
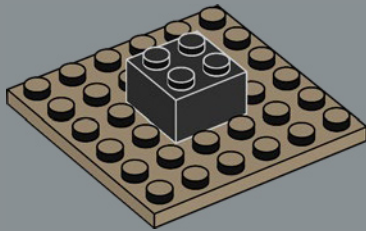

277

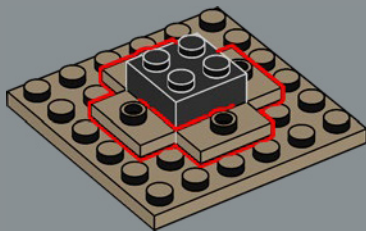

278

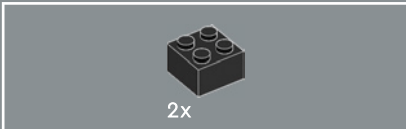
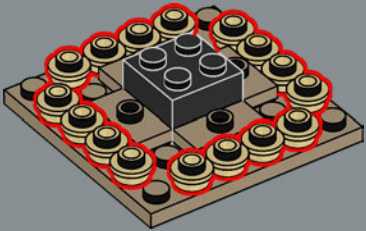

279

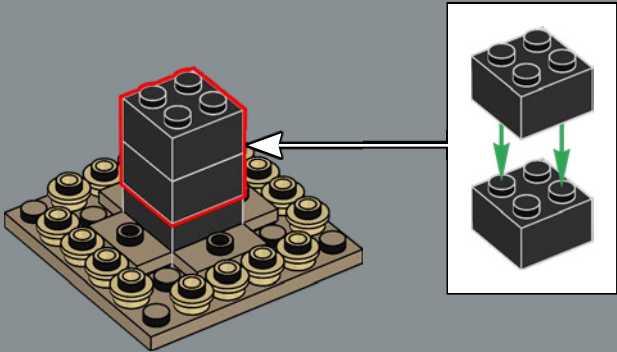



280

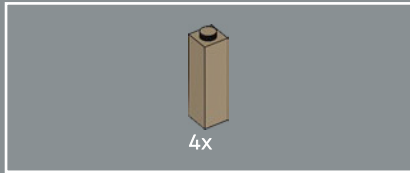
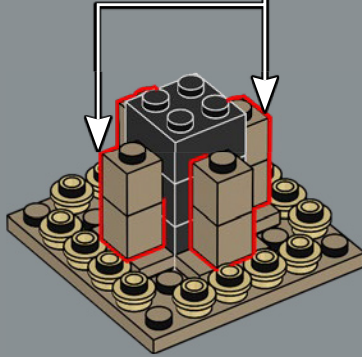
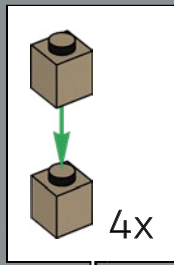

281

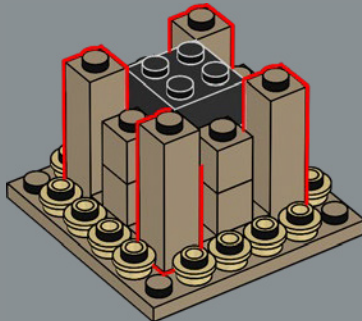

282

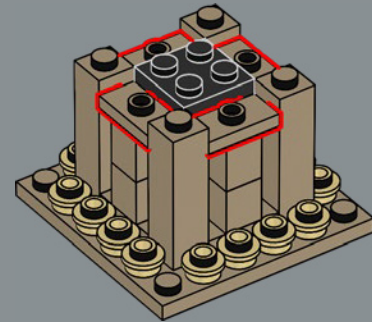

2x

283



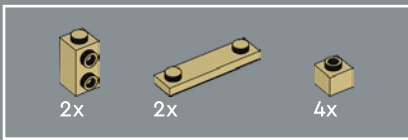

284

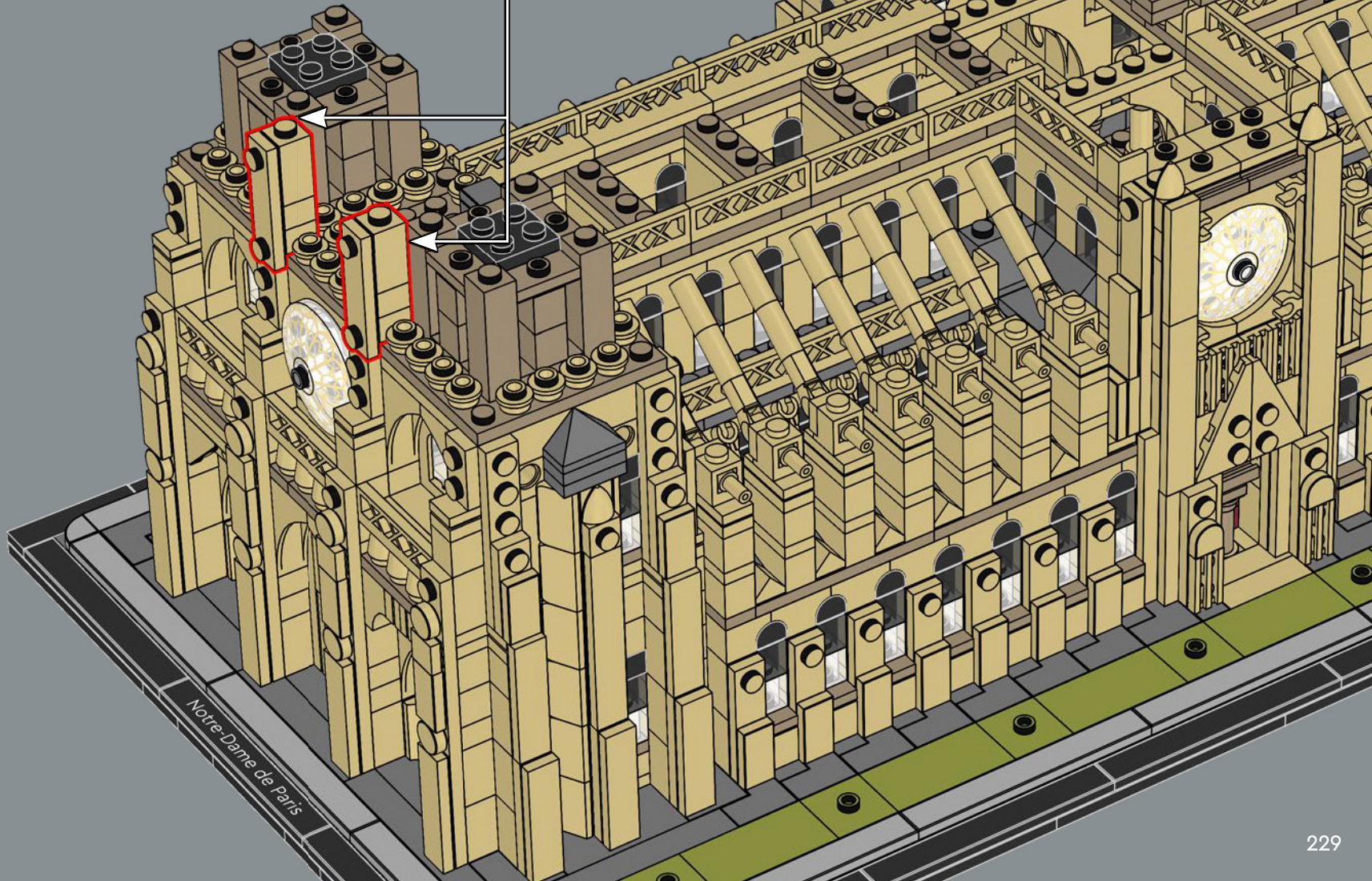
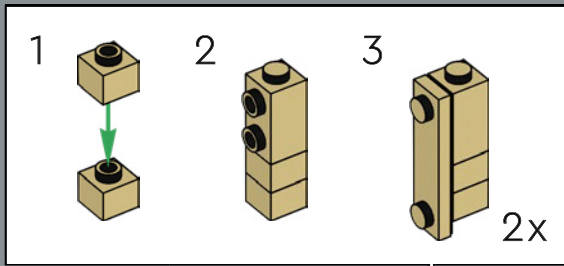



285

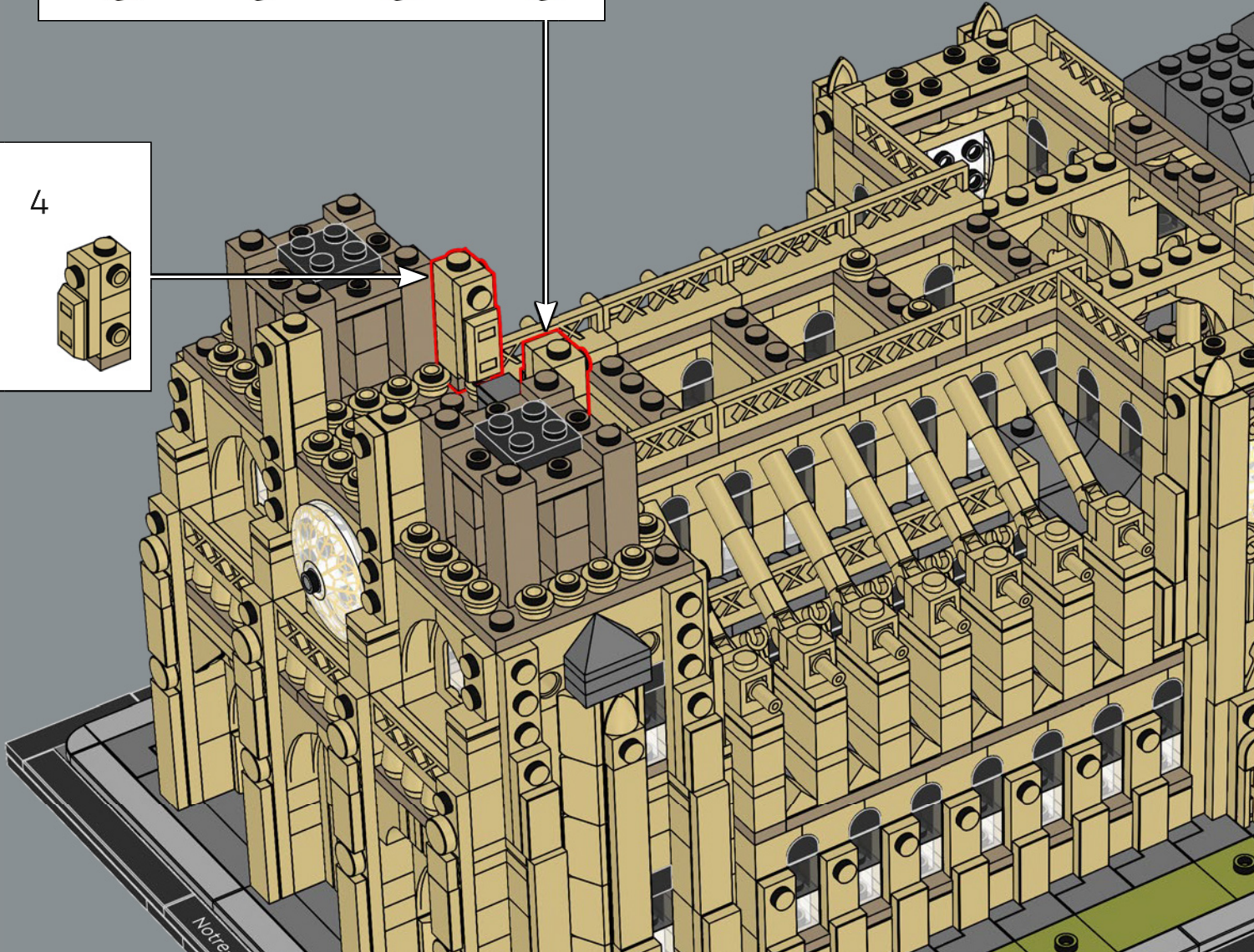
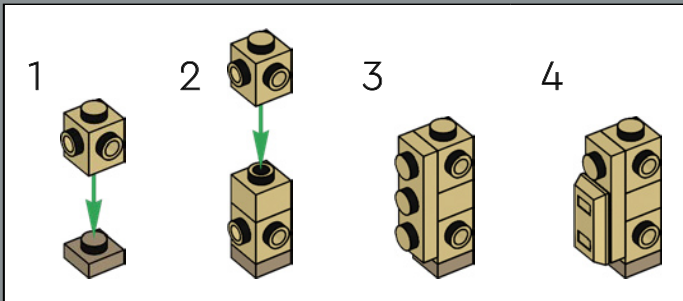
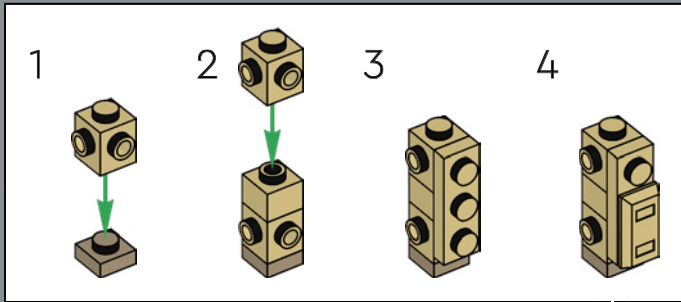

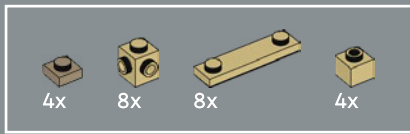

286

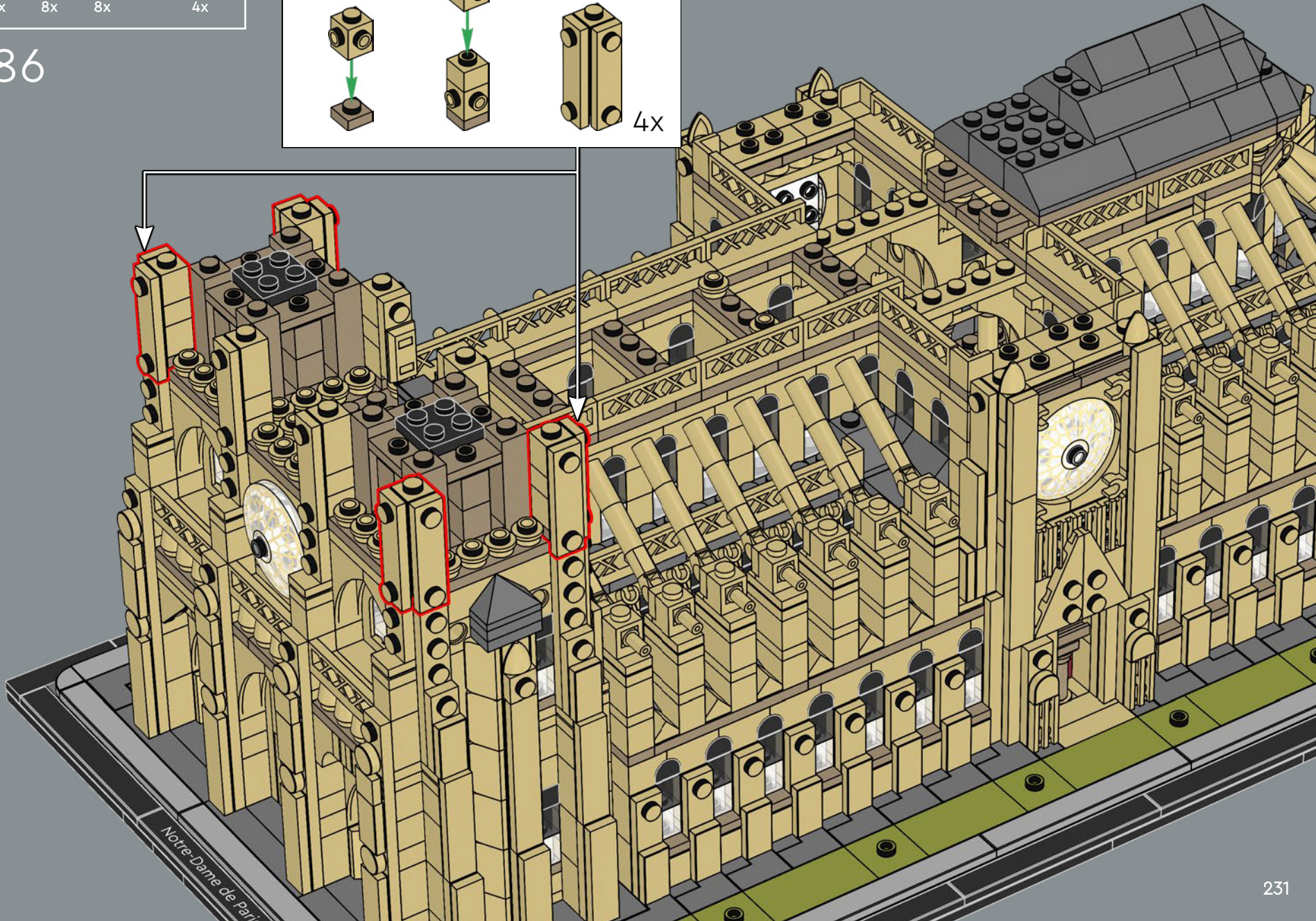
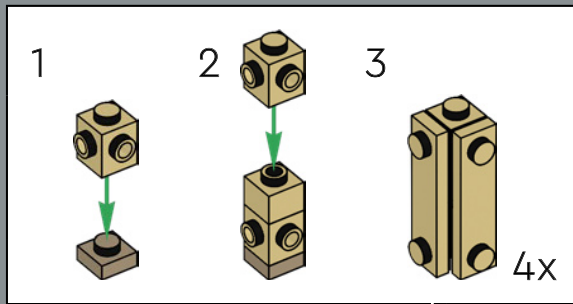



287

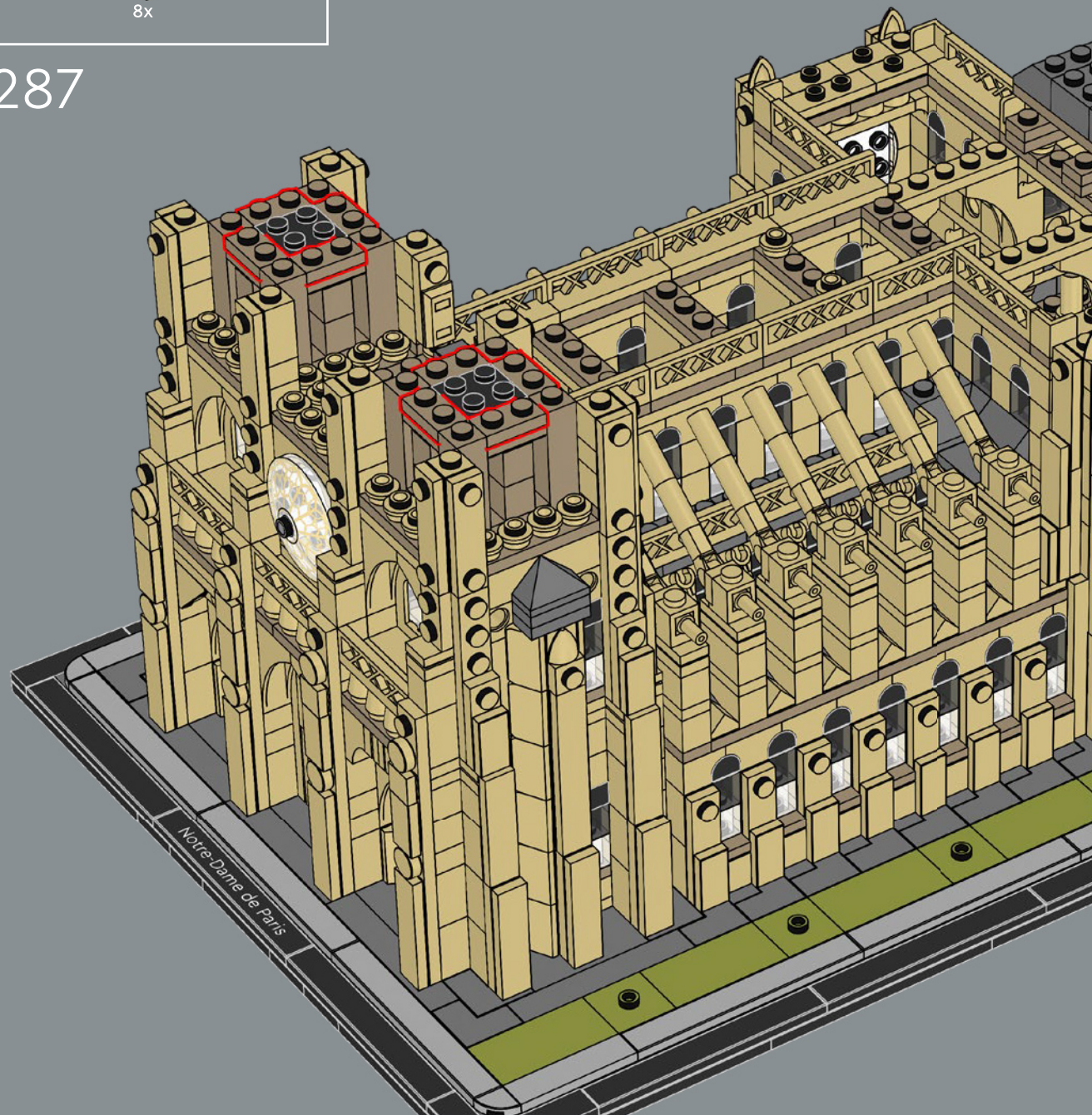





40x

288

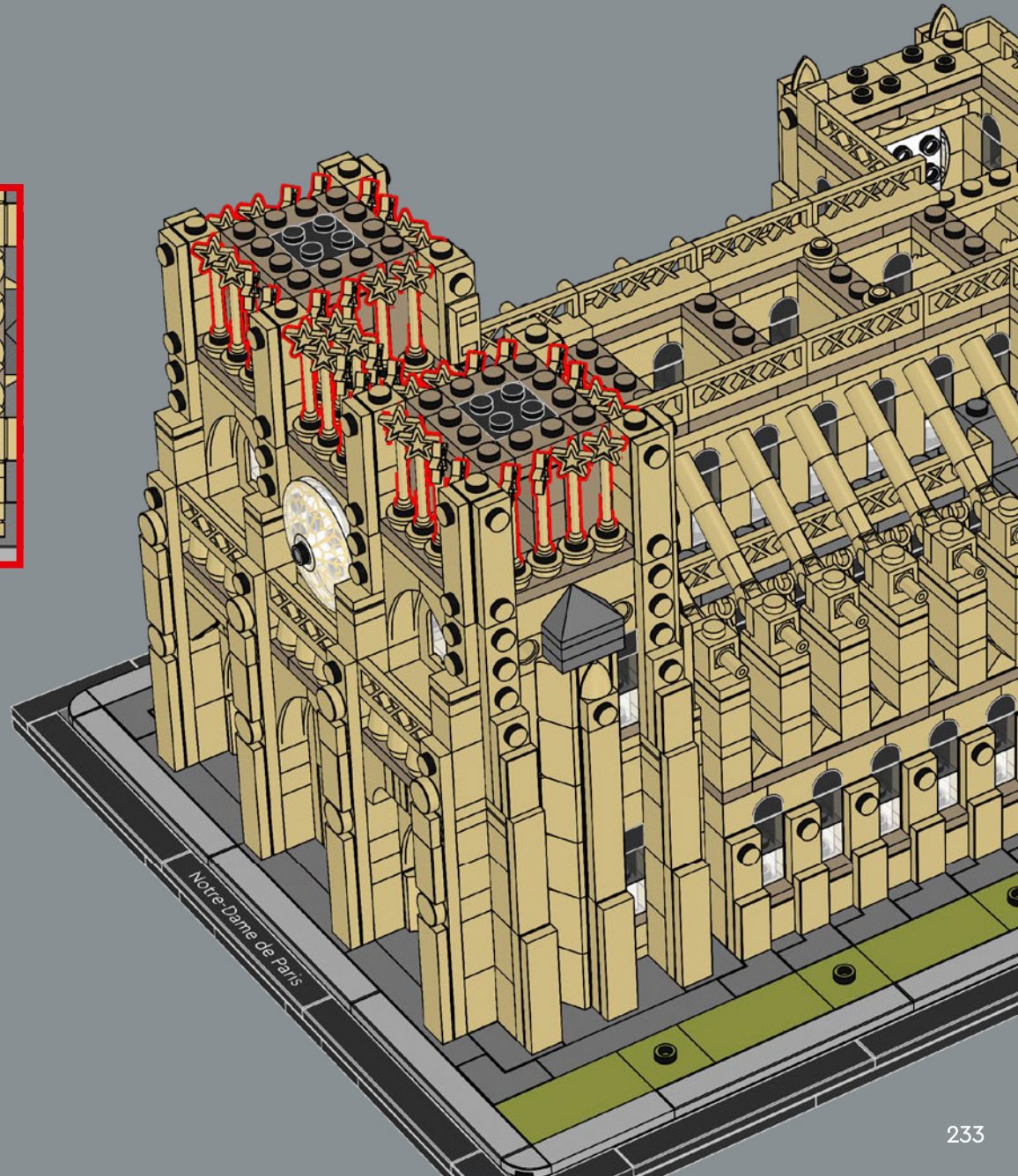
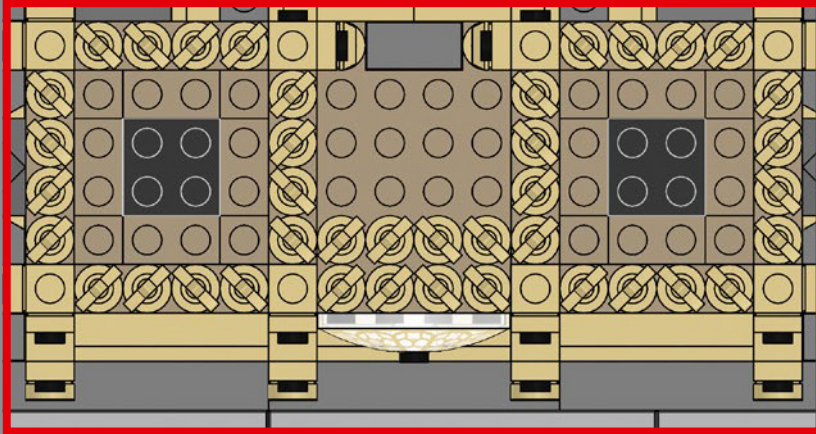

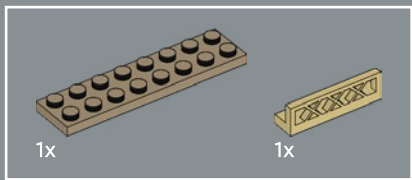

289

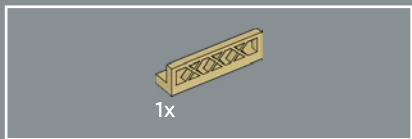
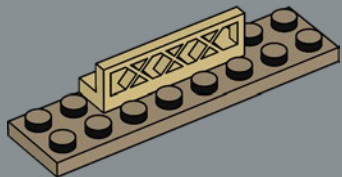

290

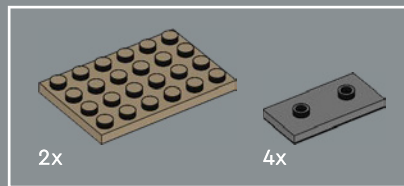
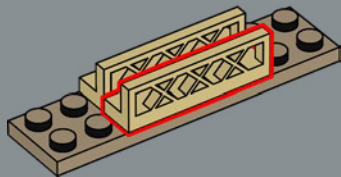

291

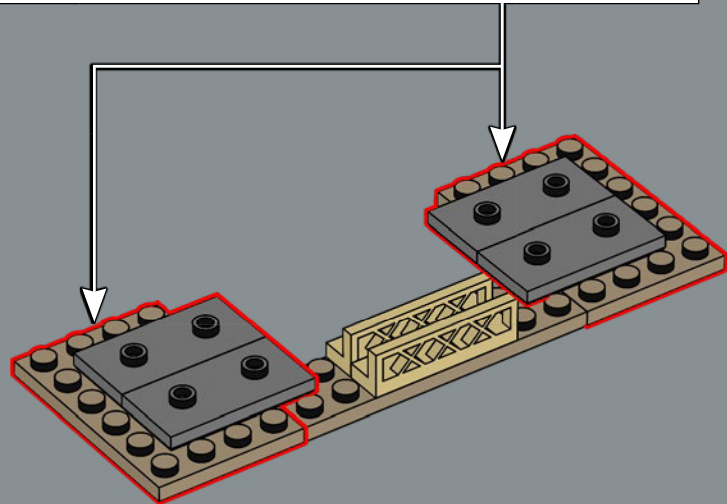
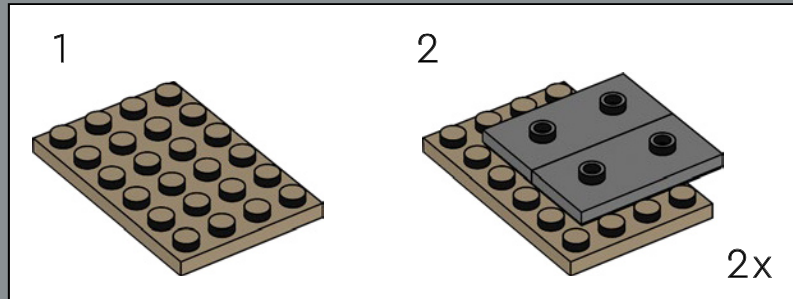

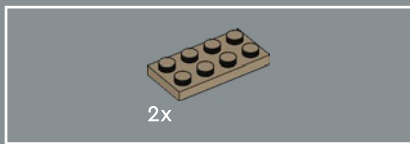

292

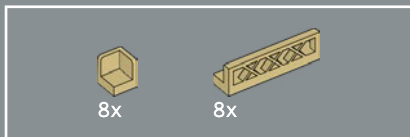
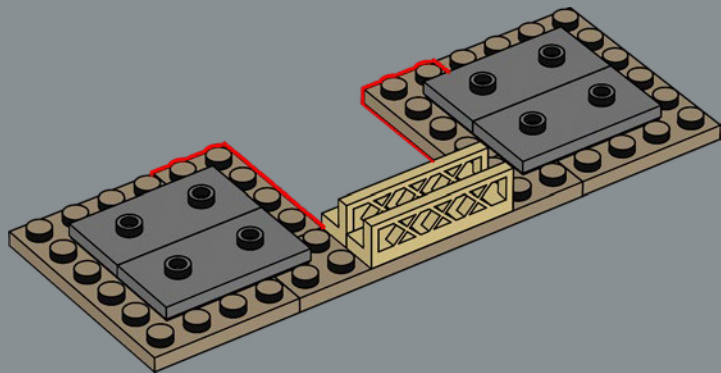

293

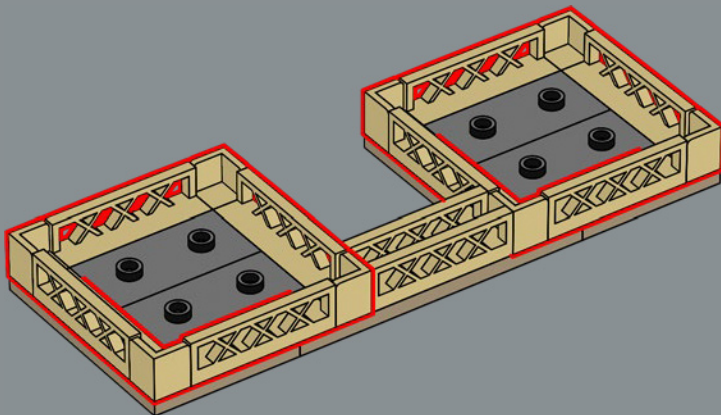

294

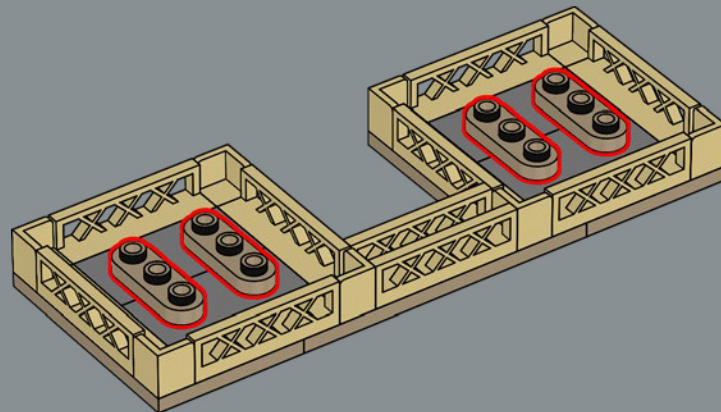

295

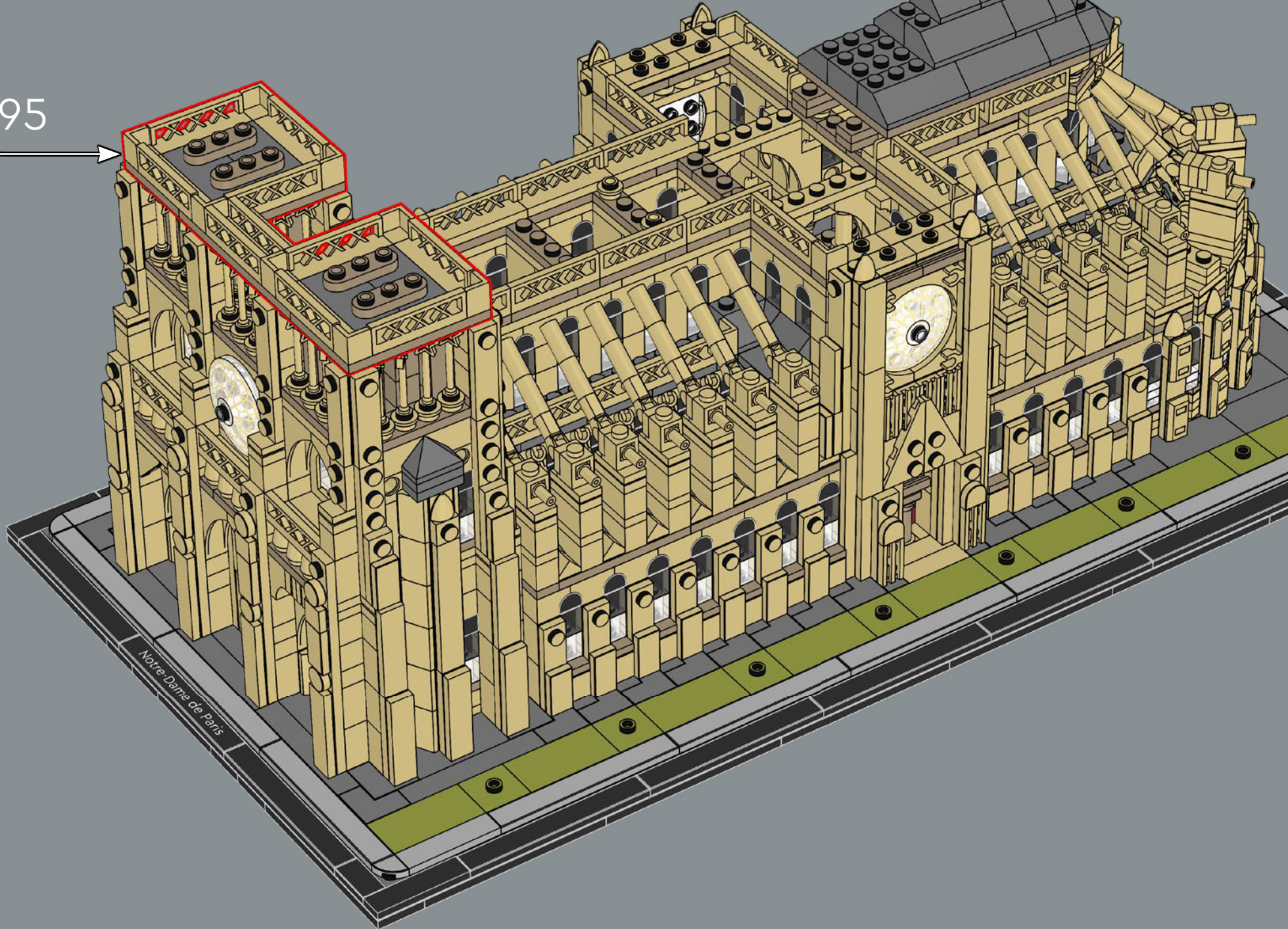

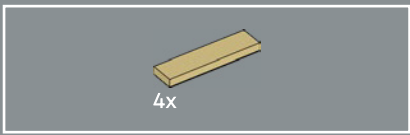

296

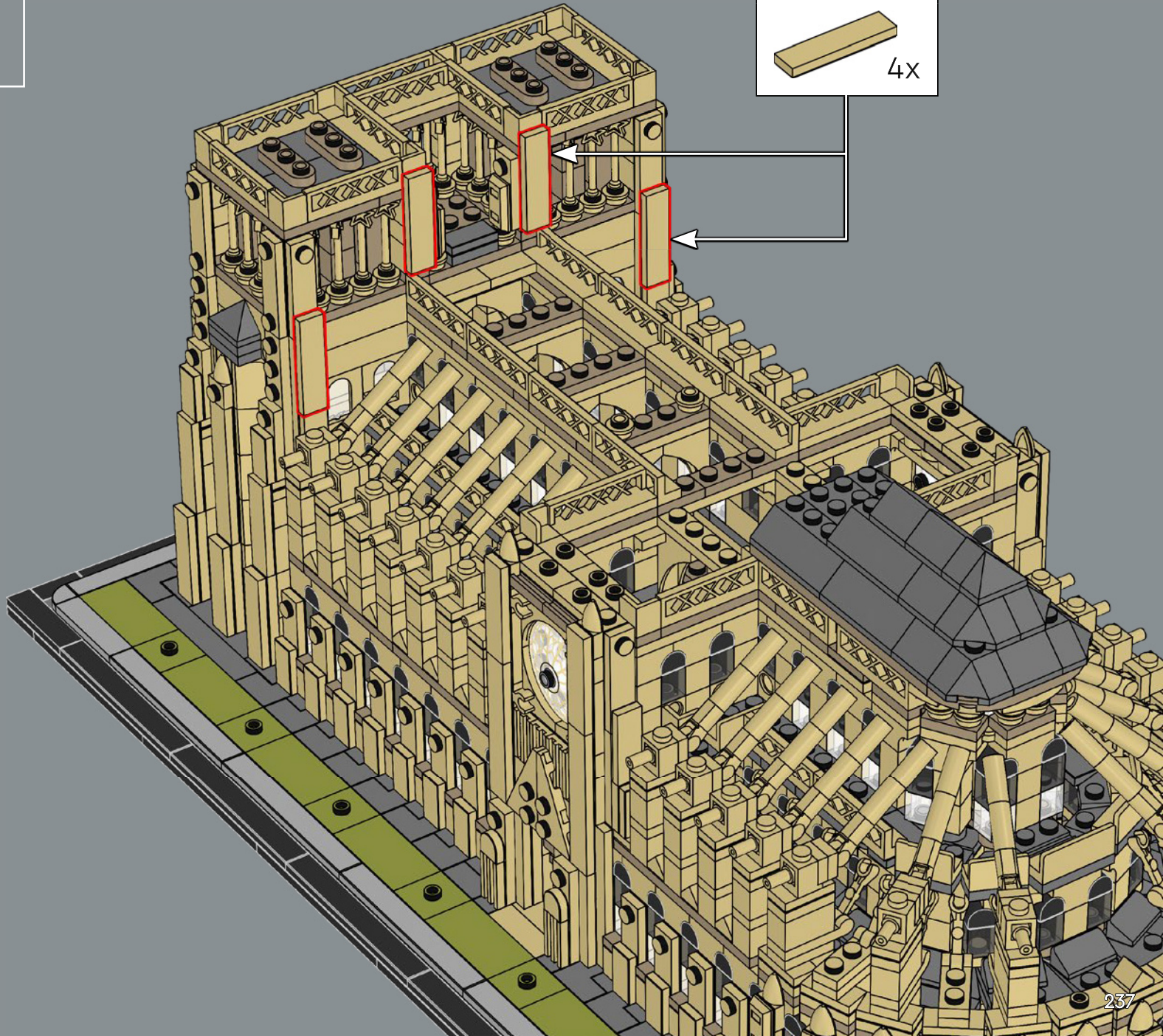
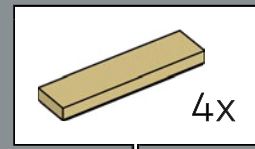



297

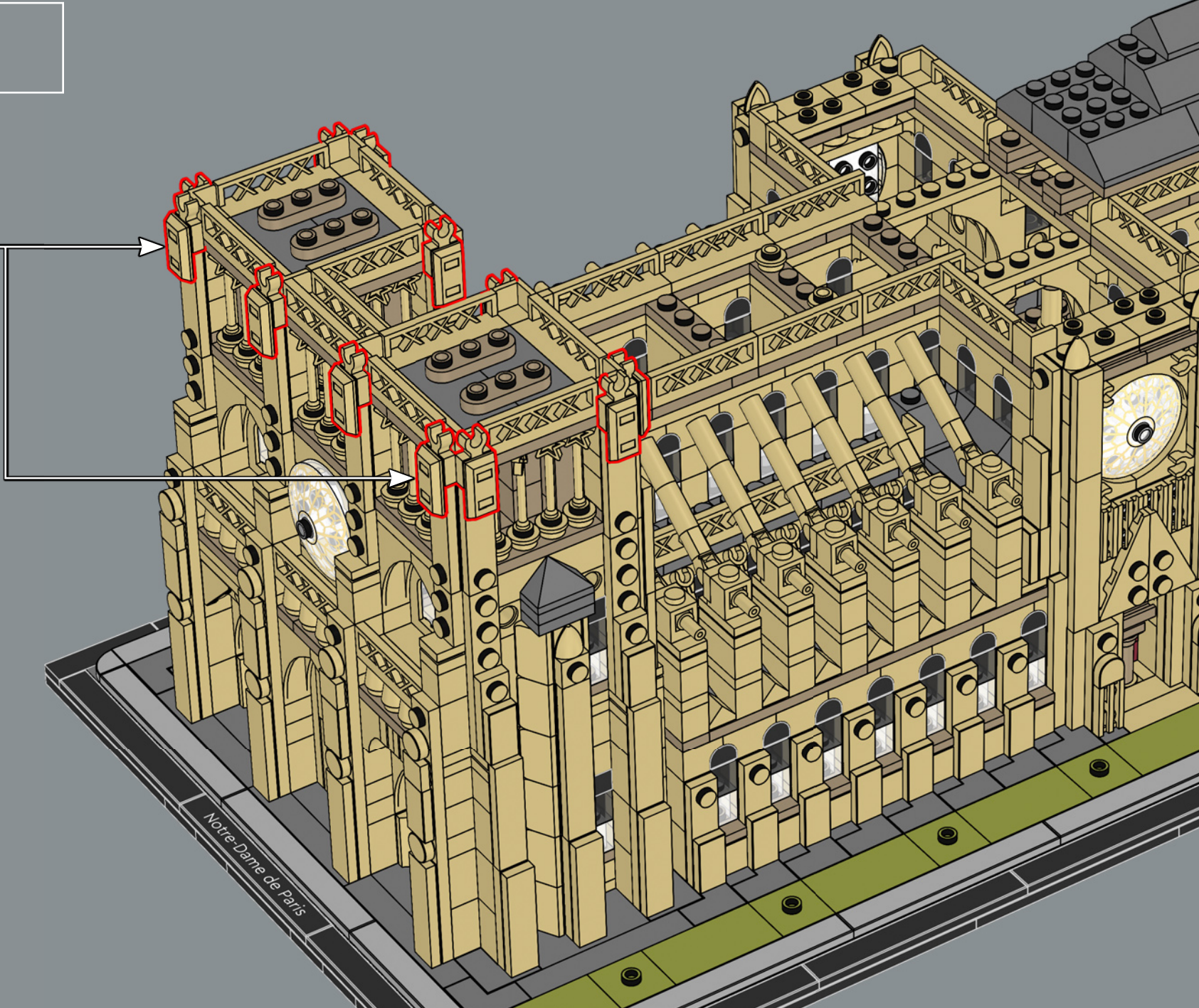
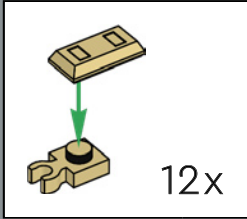

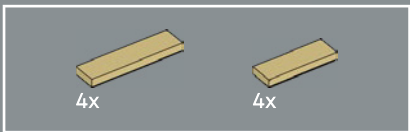

298

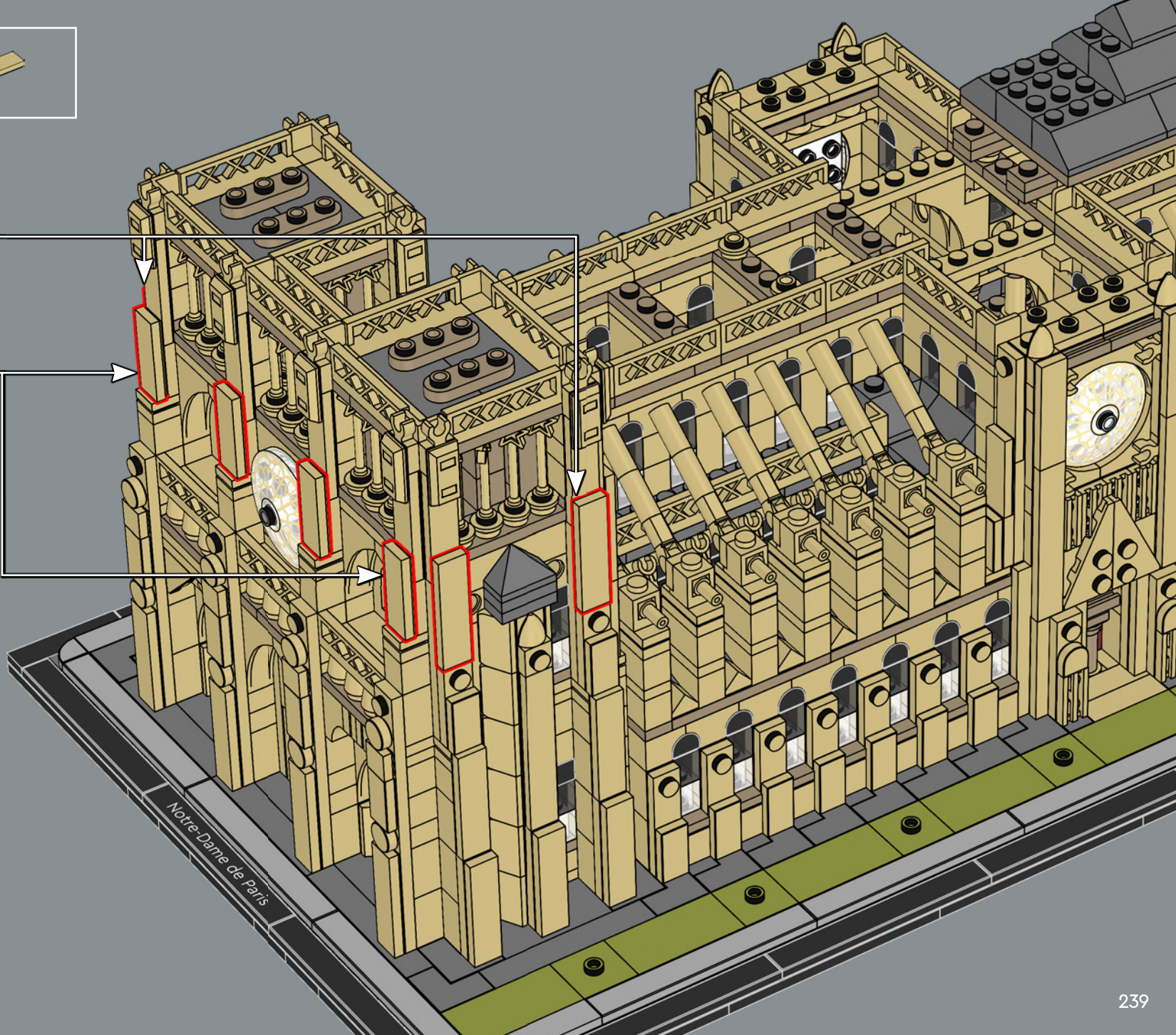
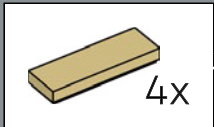
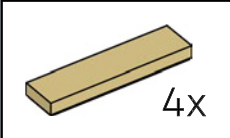



4x

299



4x

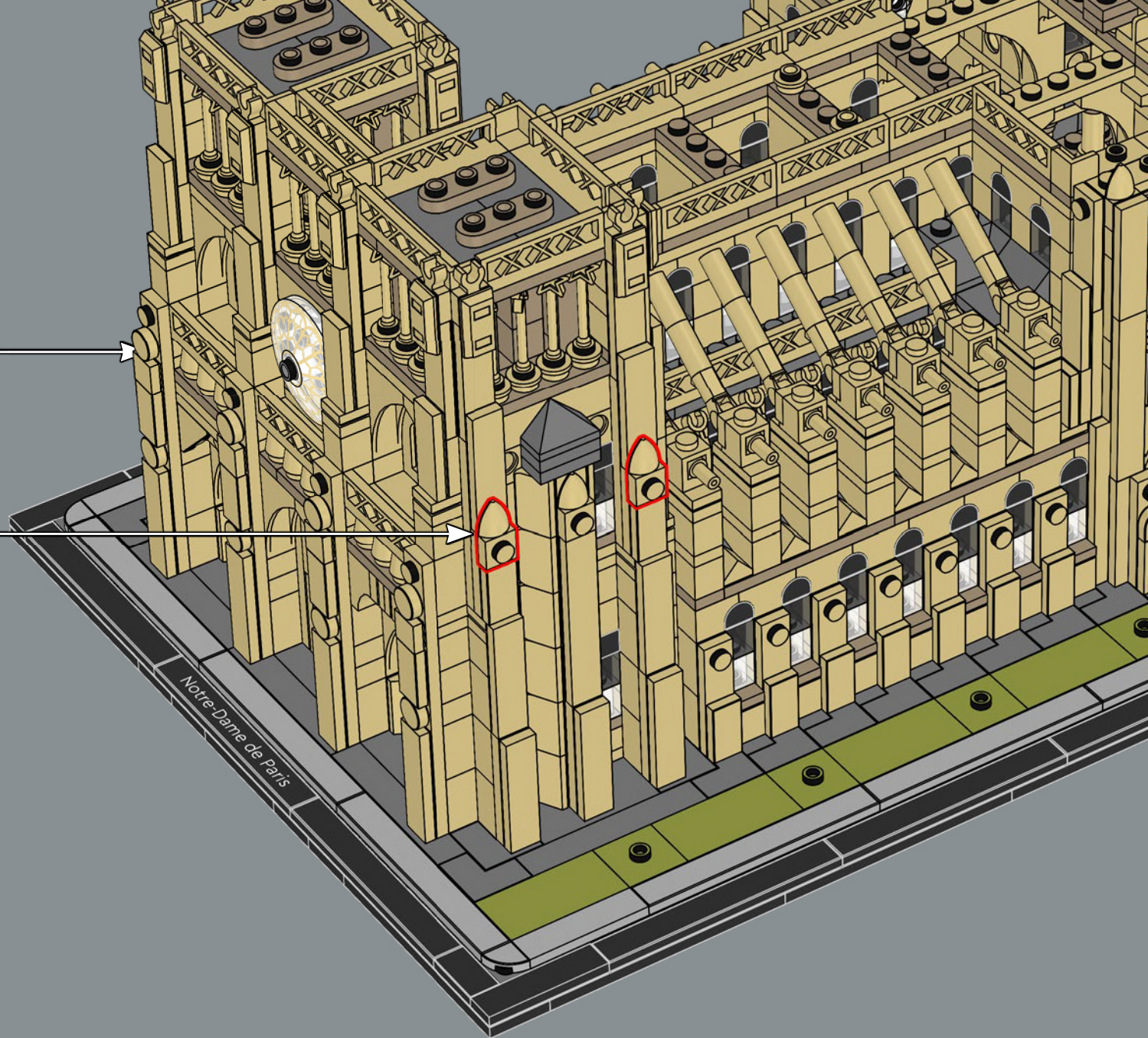



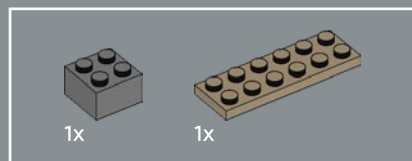
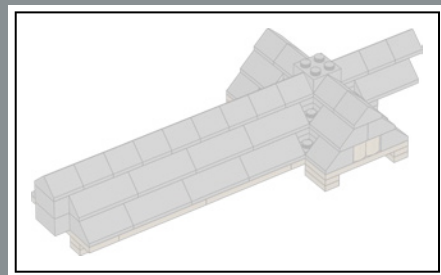

300

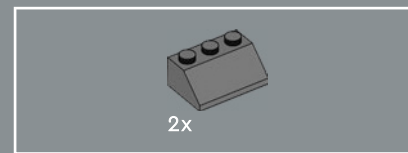
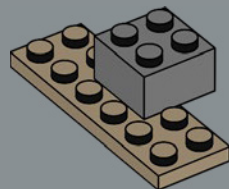

301

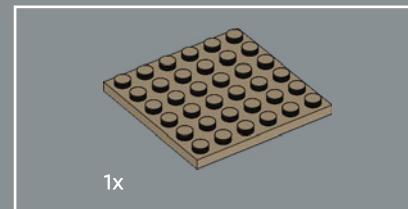
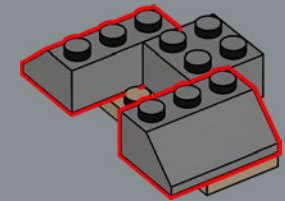

302

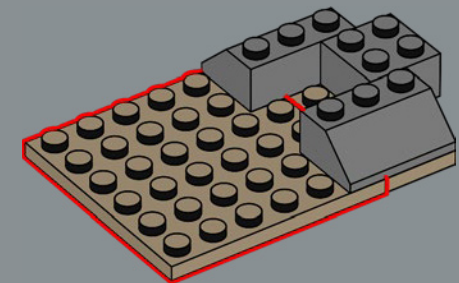

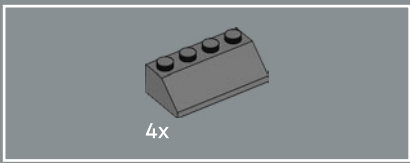

303

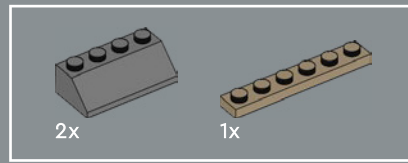
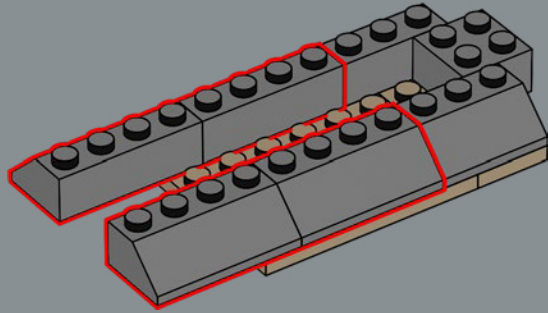

305

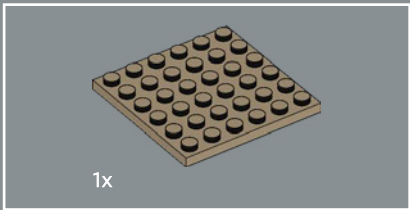
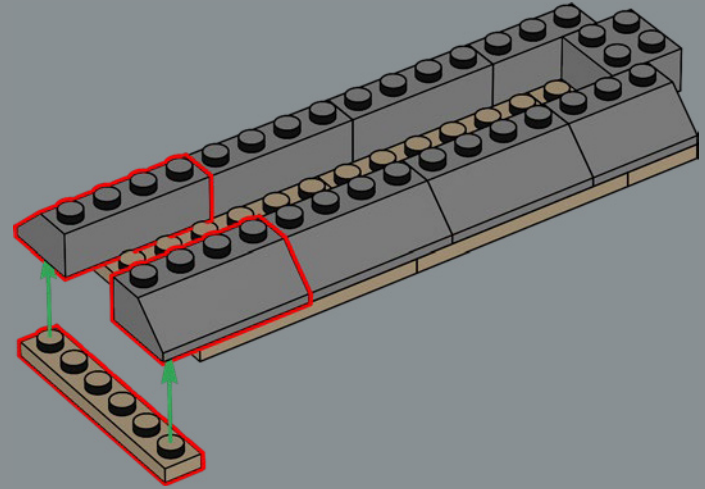

304

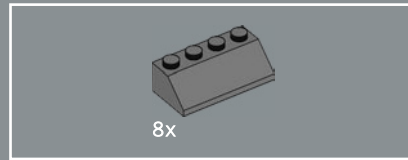
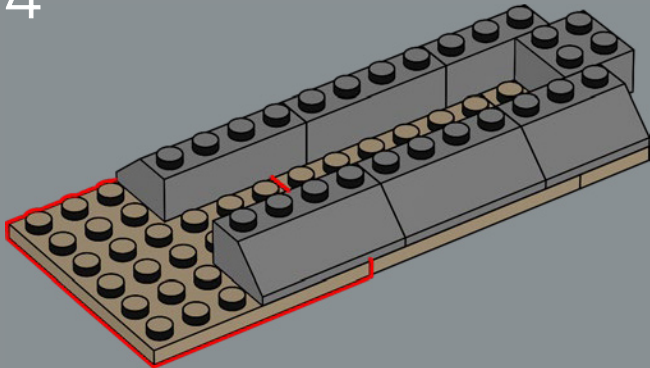

306

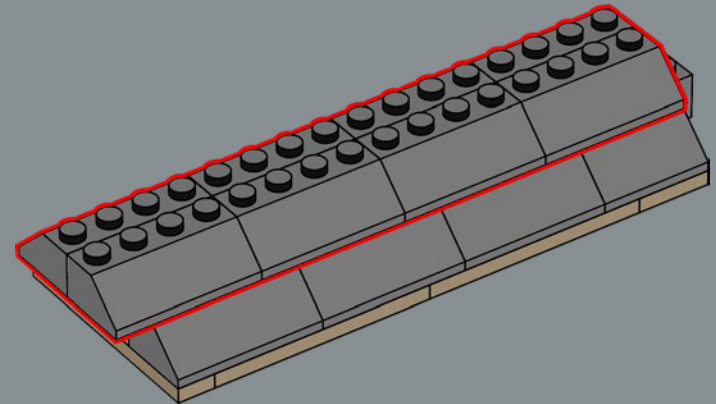

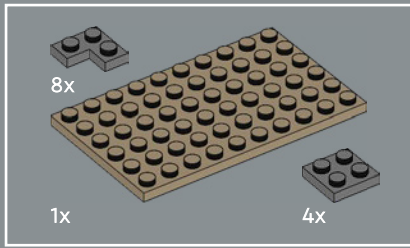

307

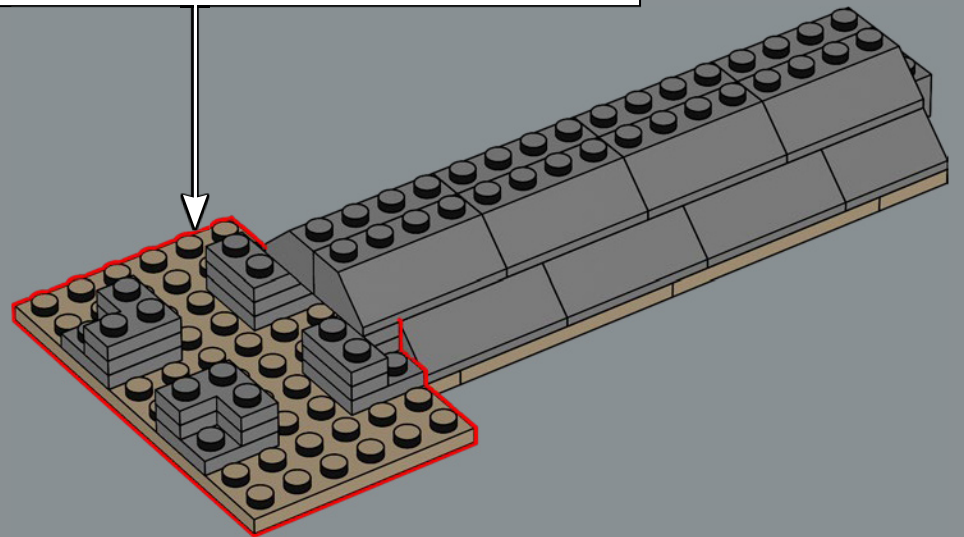
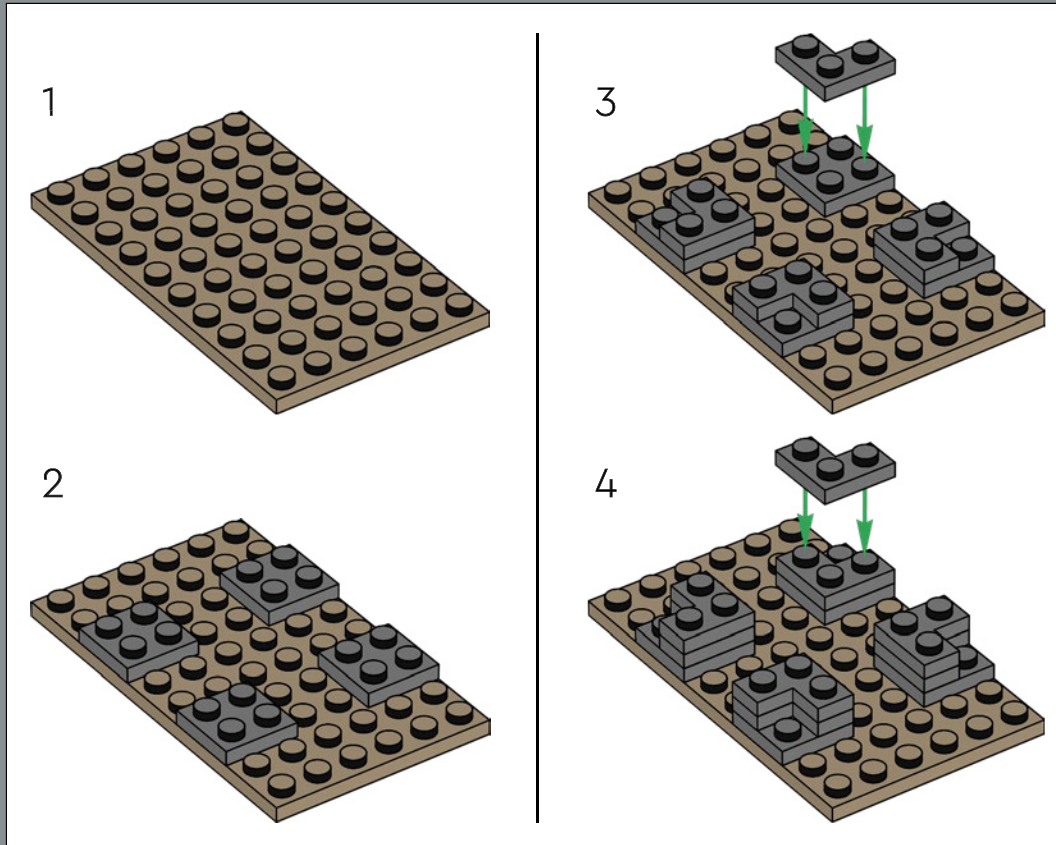

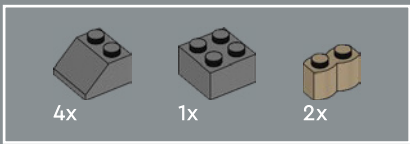

308

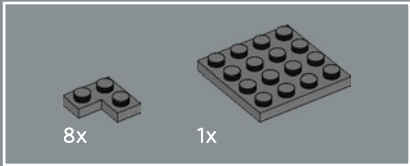
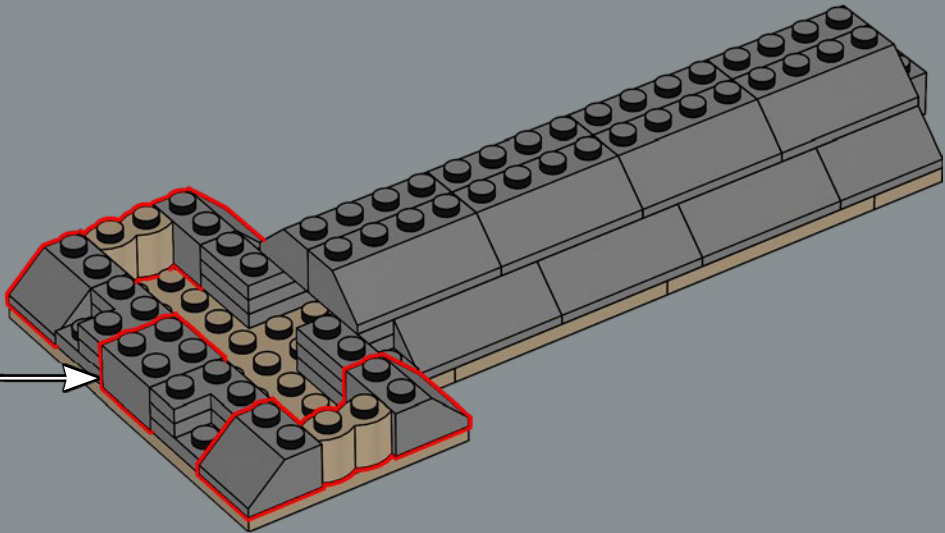
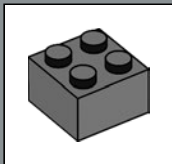

309

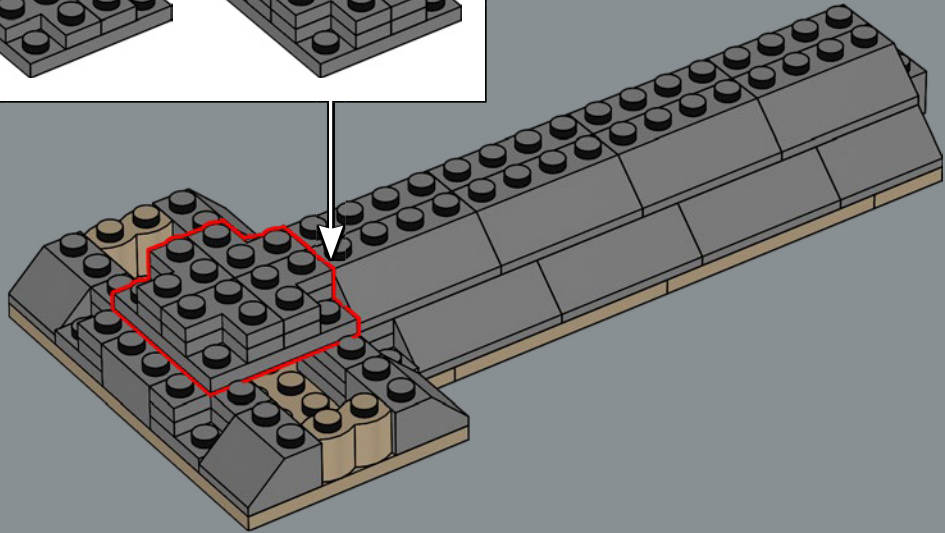
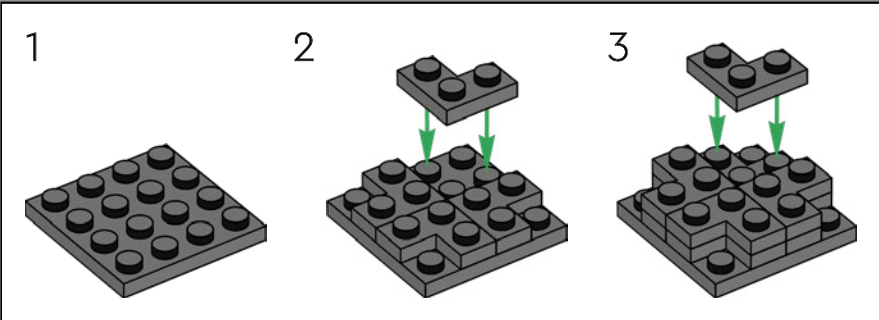

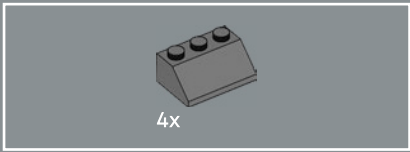

310

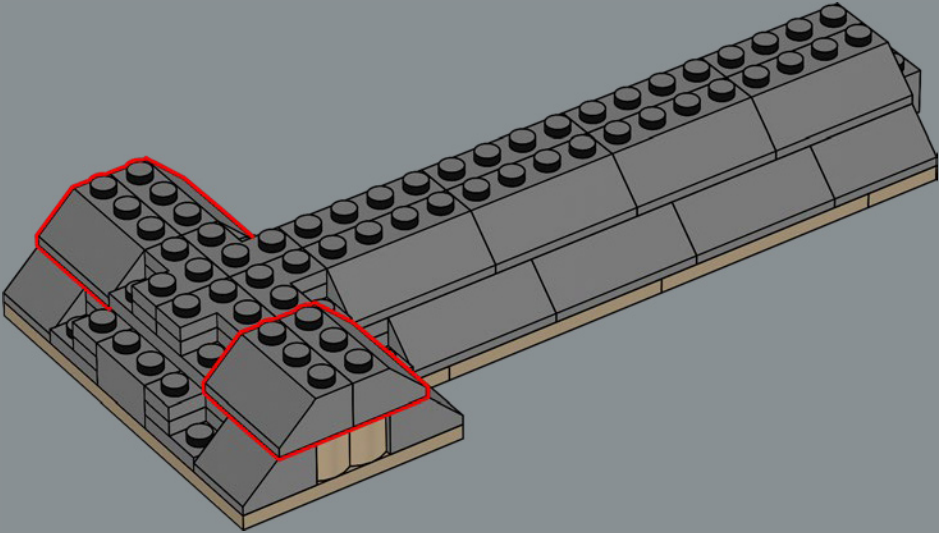

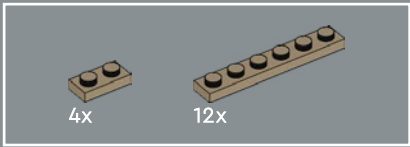

311

1

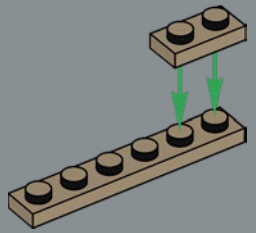

2

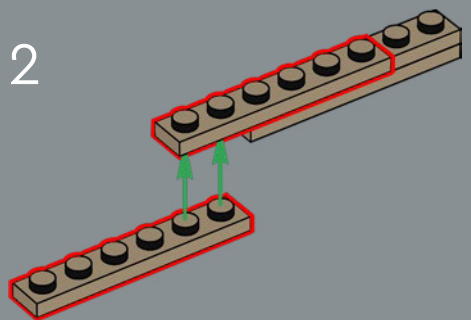

3

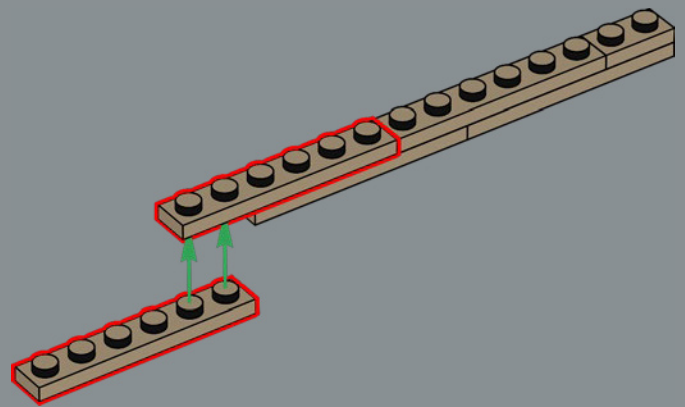

4

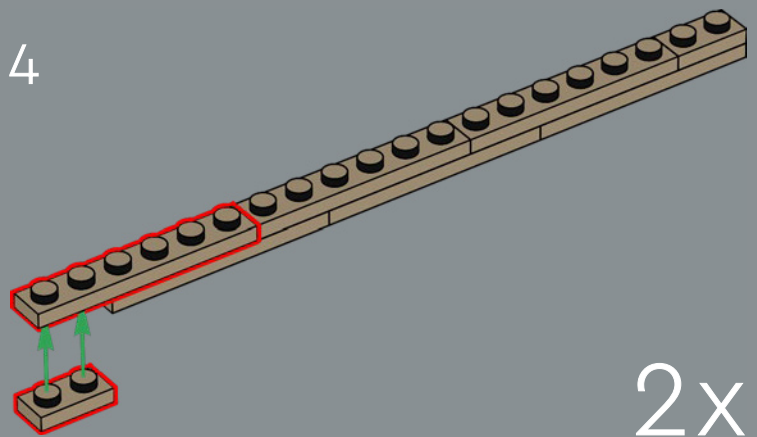

2x

Das Bauholz für das Holztragwerk der Kathedrale lieferten 1300 Eichen.  
Das entspricht einer Waldfläche von 21 Hektar.

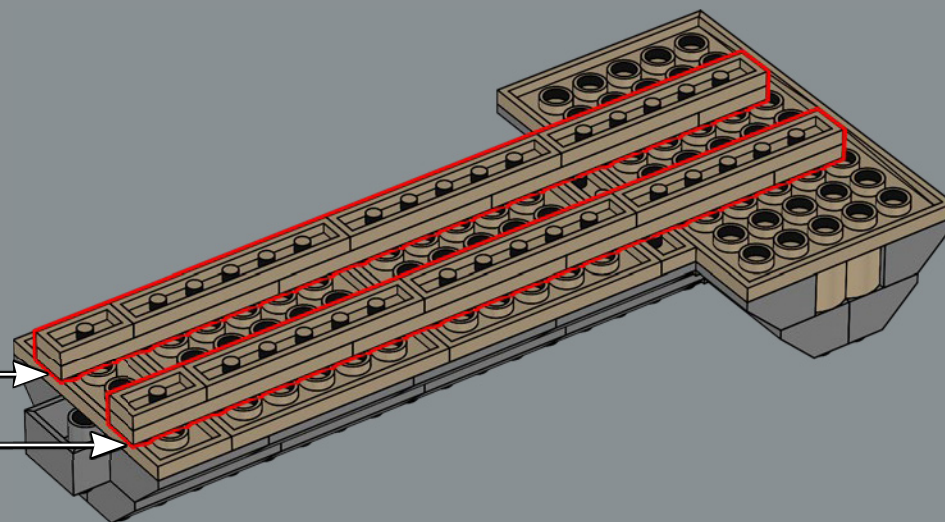



8x

312

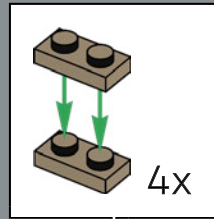

4x

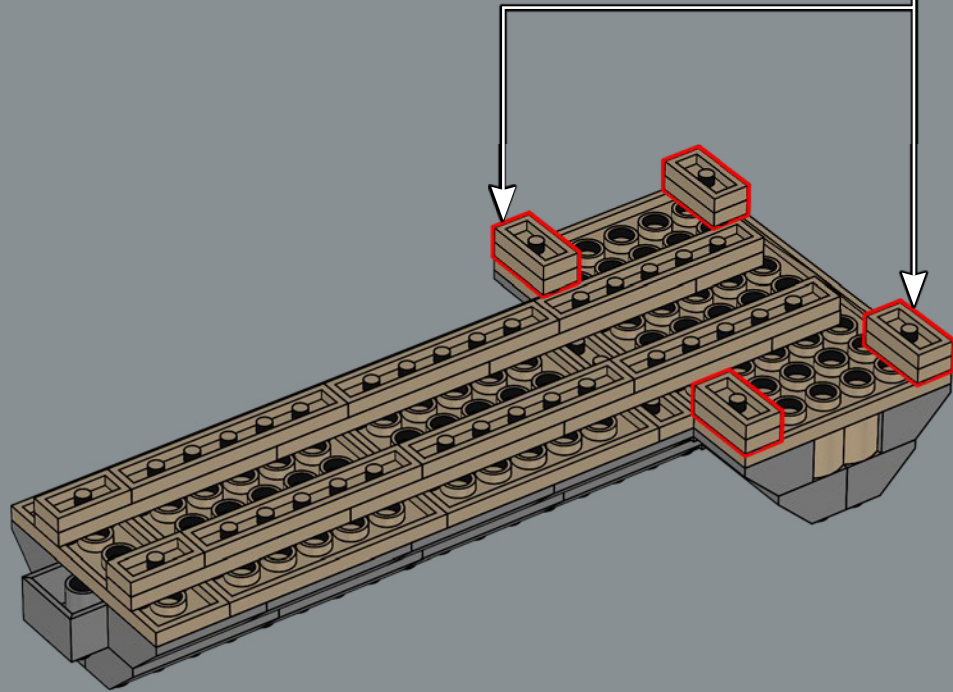



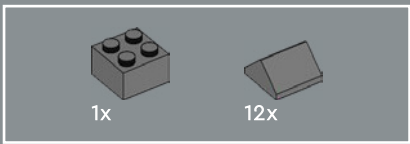

313

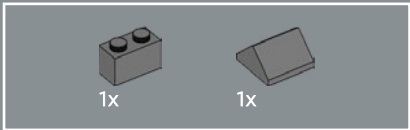
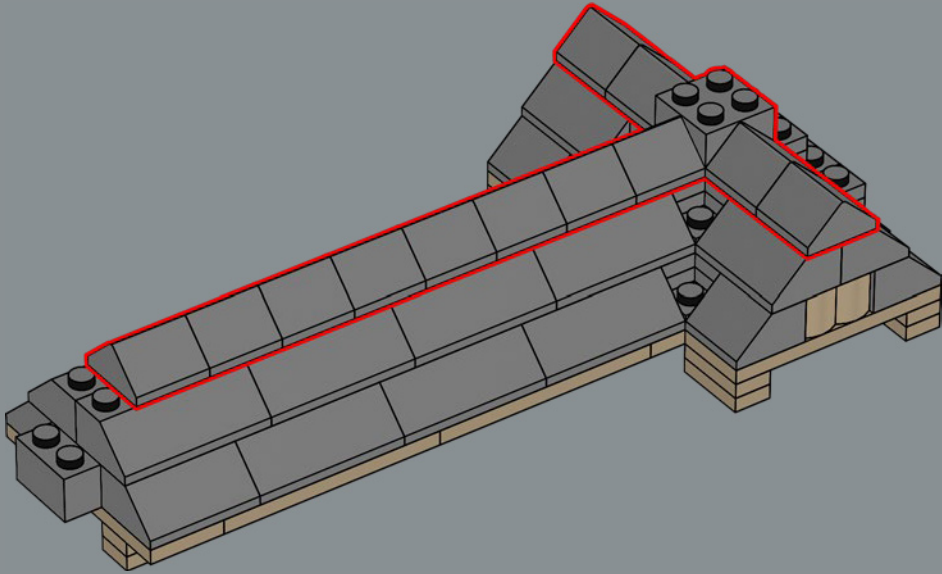

314

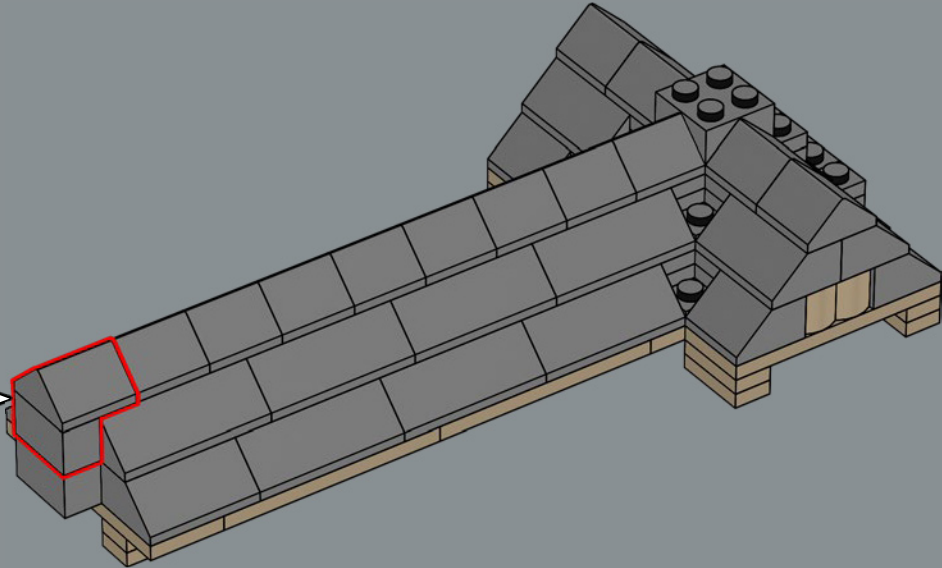
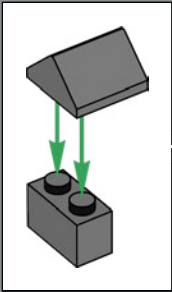

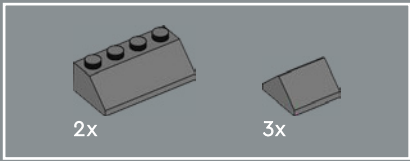

315

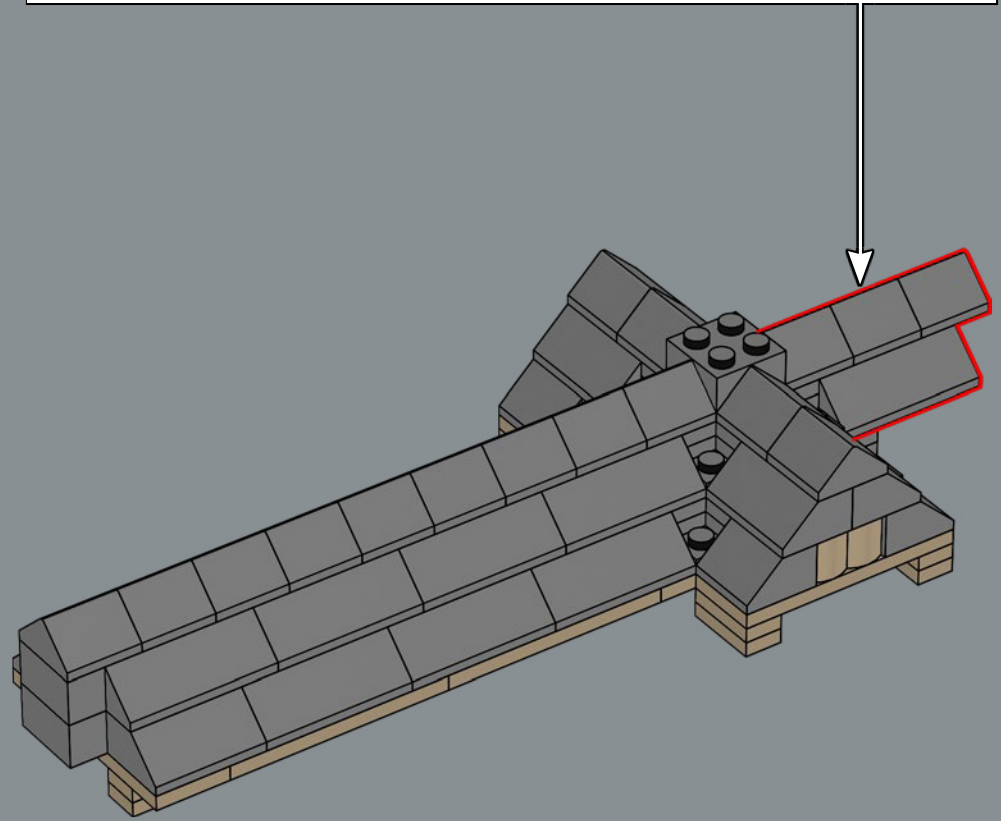
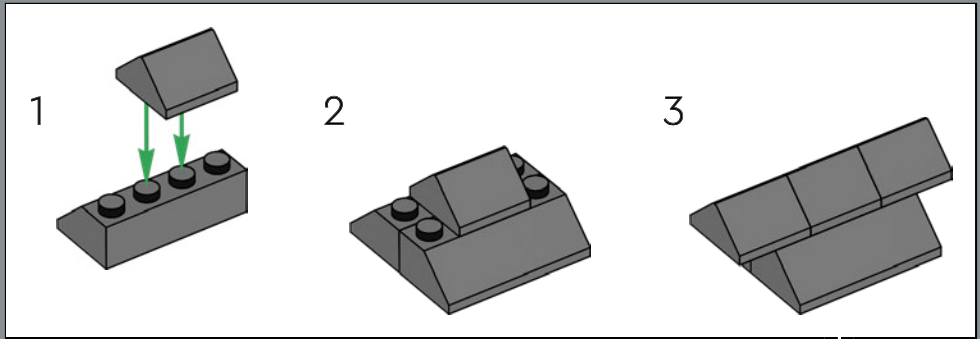

1220: Der Hauptteil der Kathedrale ist fertig,  
es fehlen nur noch die oberen Turmgeschosse.

316

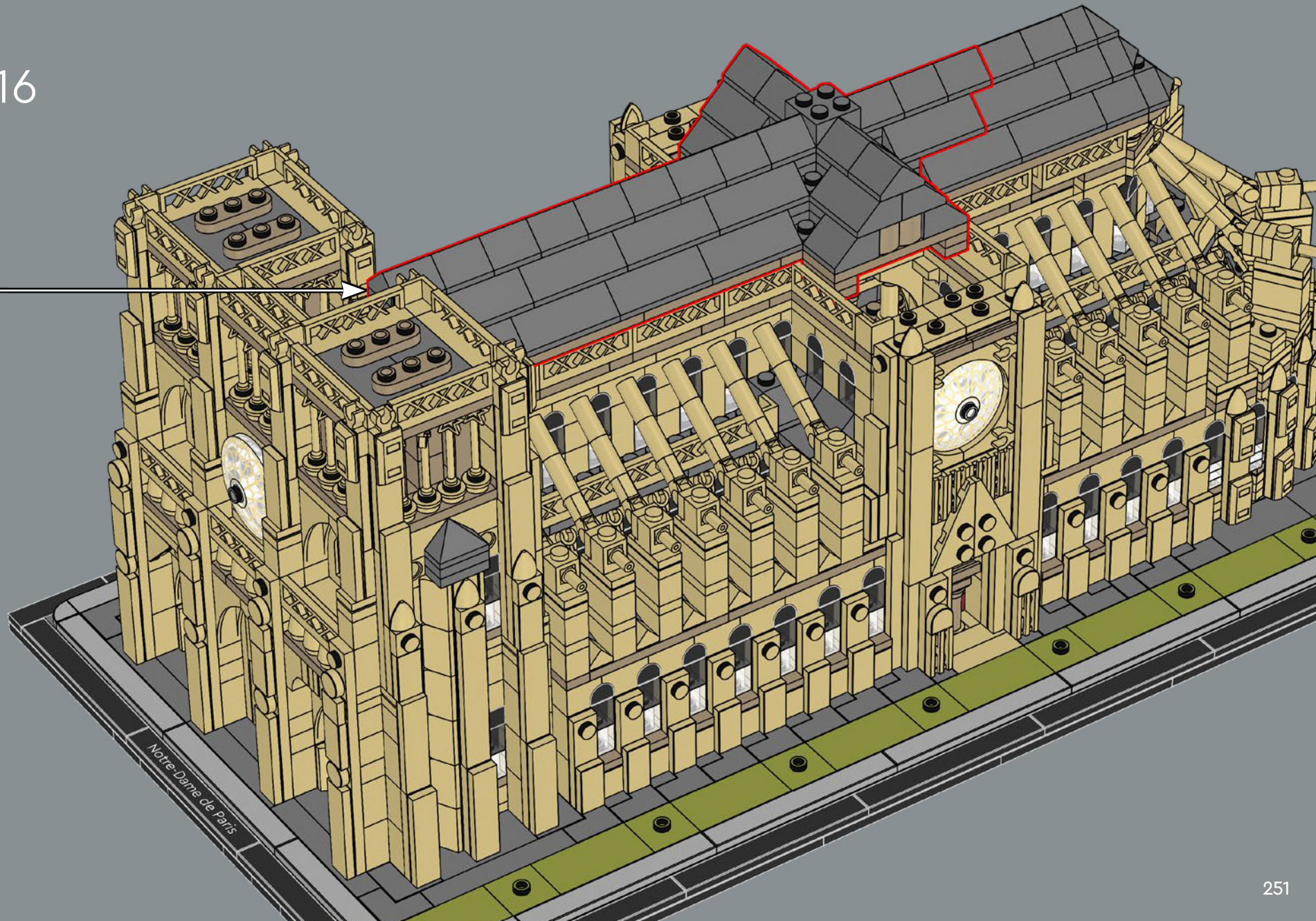

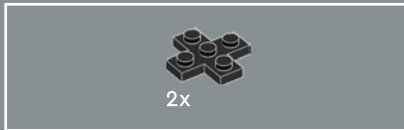
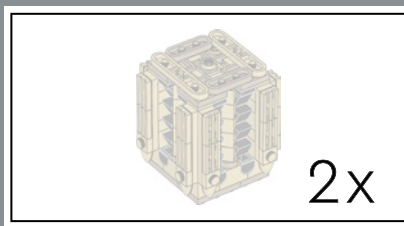

317

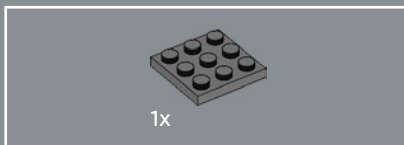
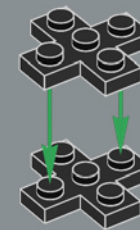

318

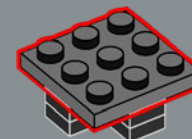

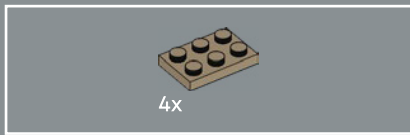

319

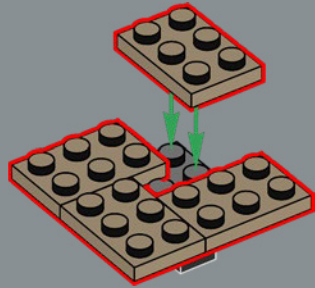

320

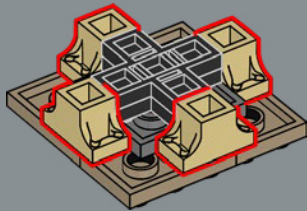

321

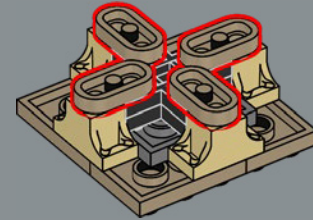

322

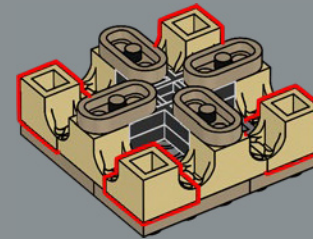



323

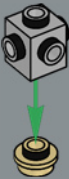

324

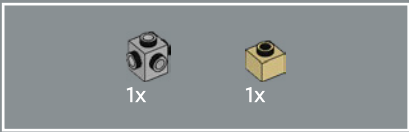

325



326



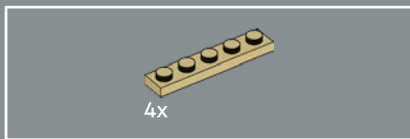

327

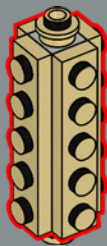

328

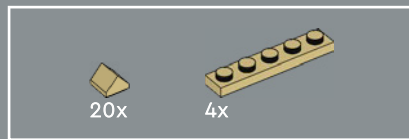
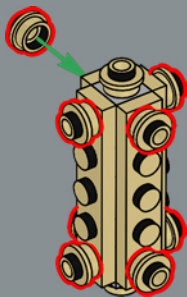

329

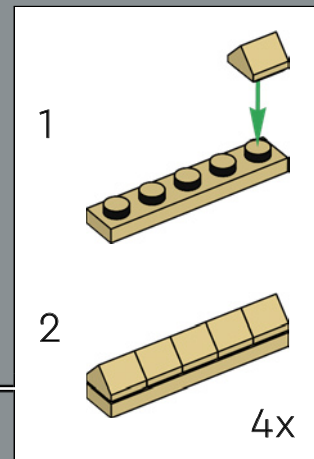
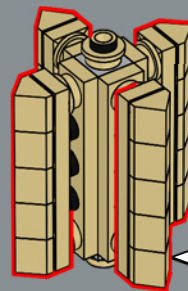

330

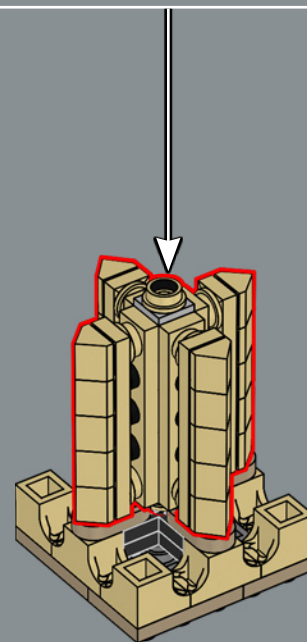

2x



331

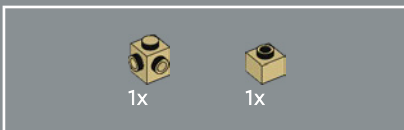

332

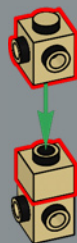

333







337

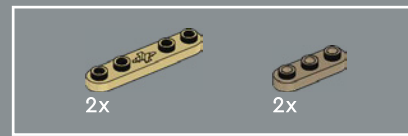
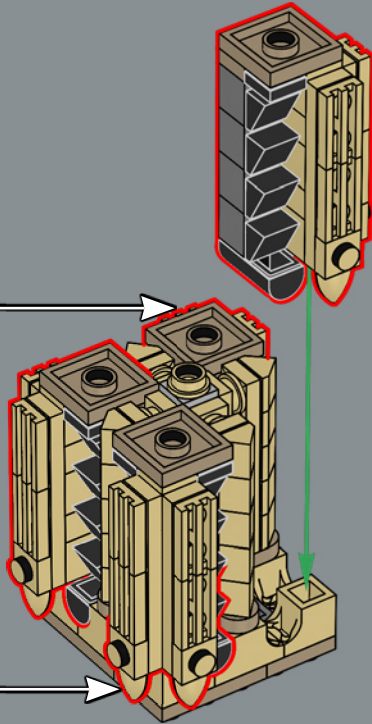

338

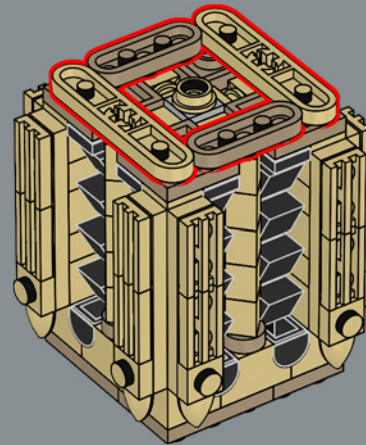

2x

Die Türme beherbergen die legendären Glocken der Kathedrale.  
Die ersten Glocken wurden im nördlichen Turm eingebaut,  
der auch als *Grosse Tour* oder *Guillaume-Turm* bezeichnet wird.

339

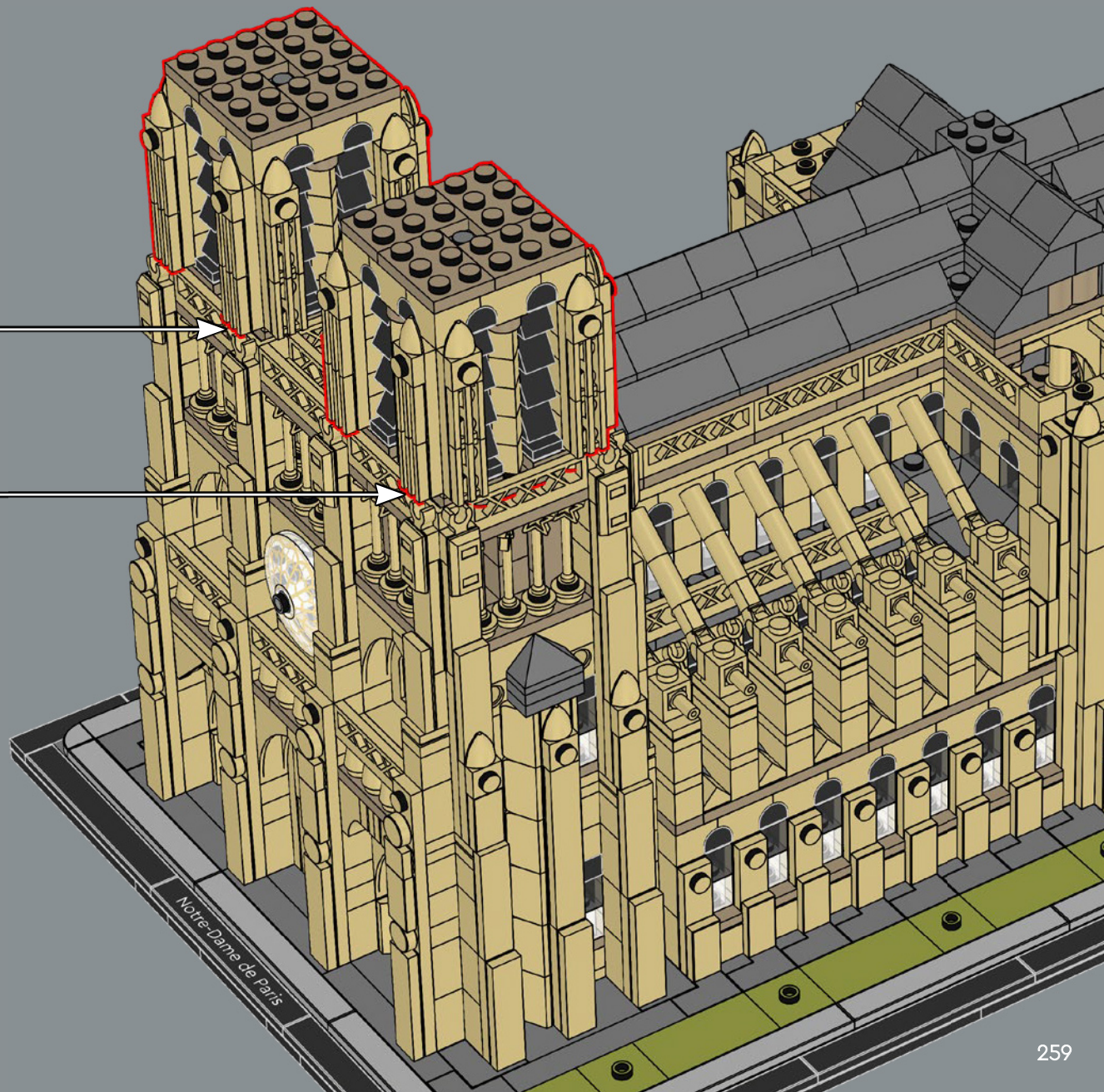



340

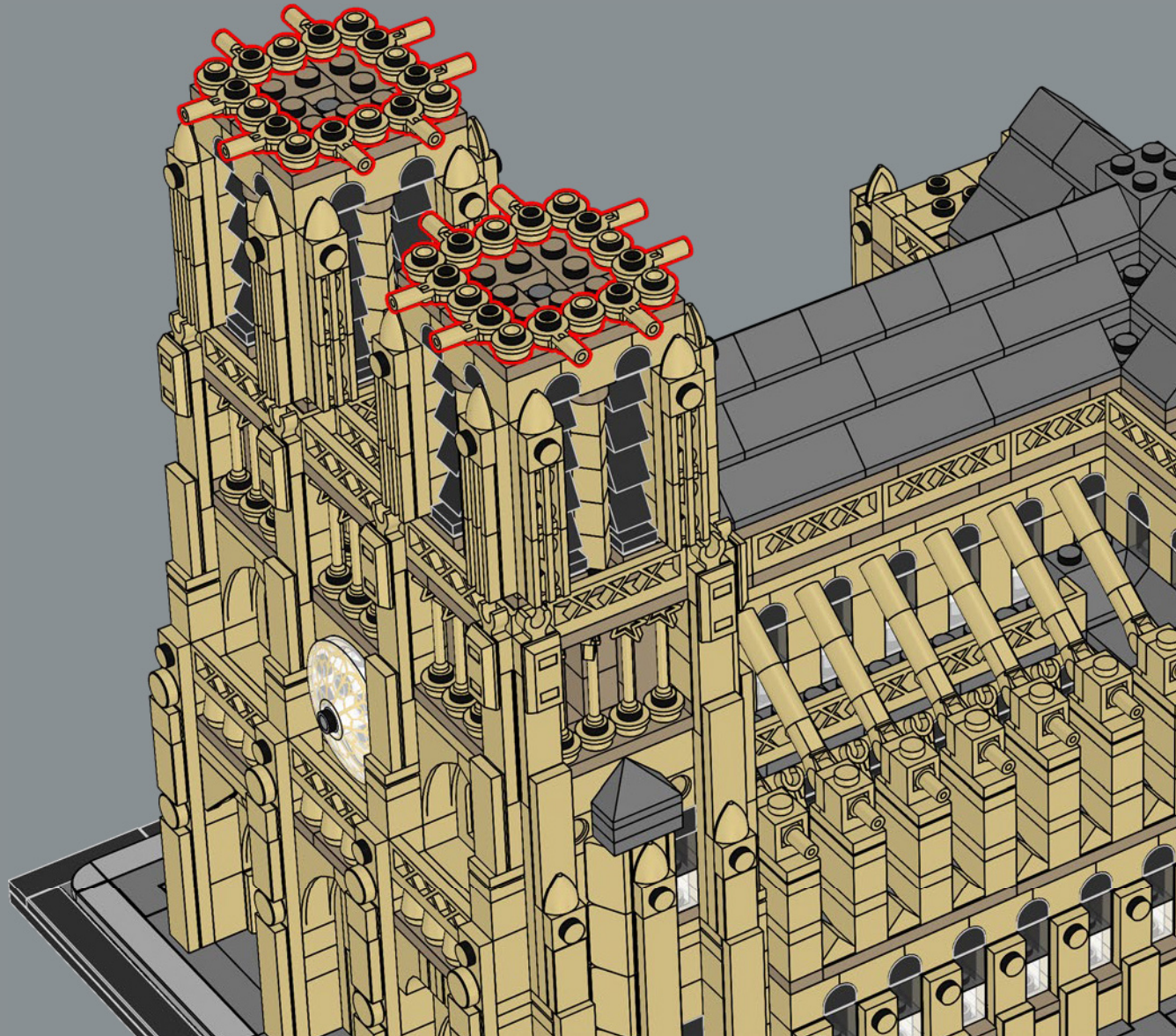



341

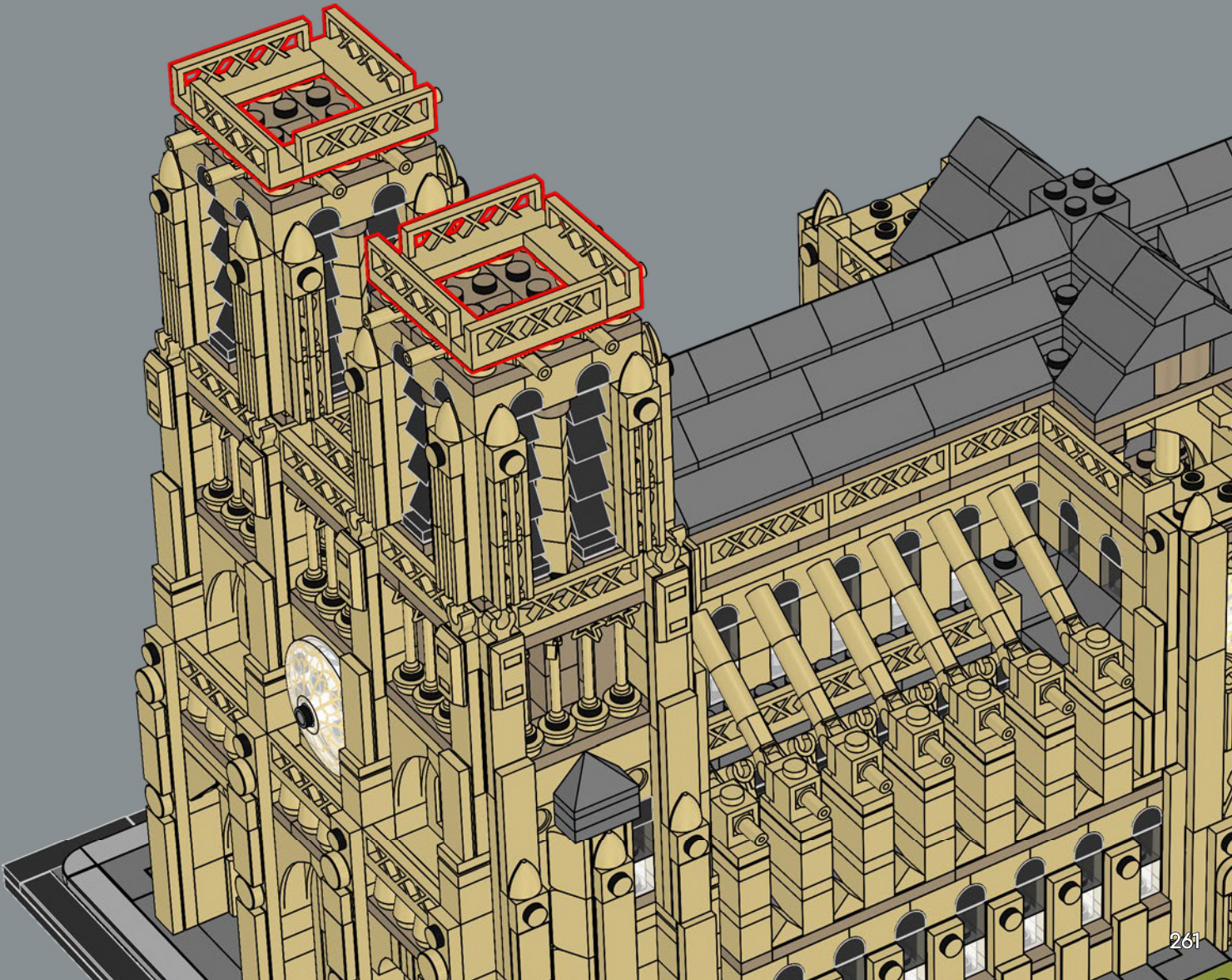

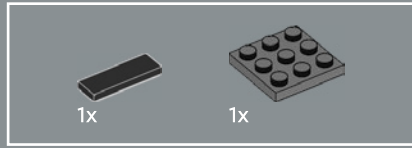
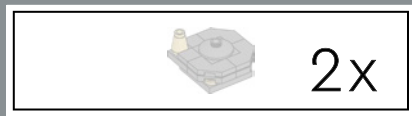

342

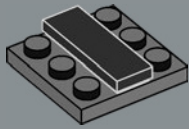

343

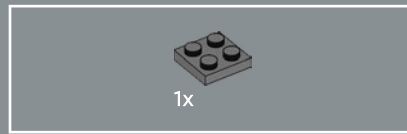
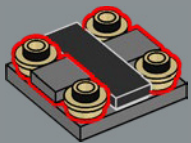

344

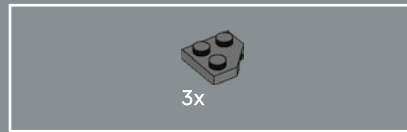
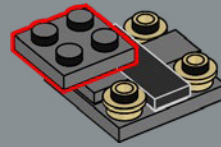

345

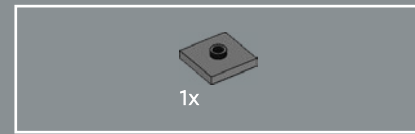
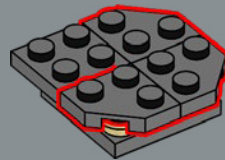

346

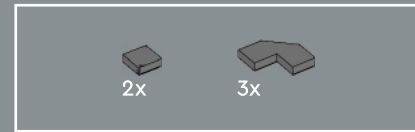
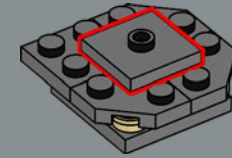

347

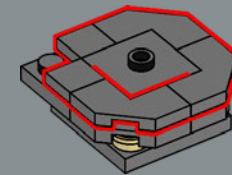



348

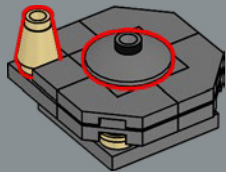

2x

349

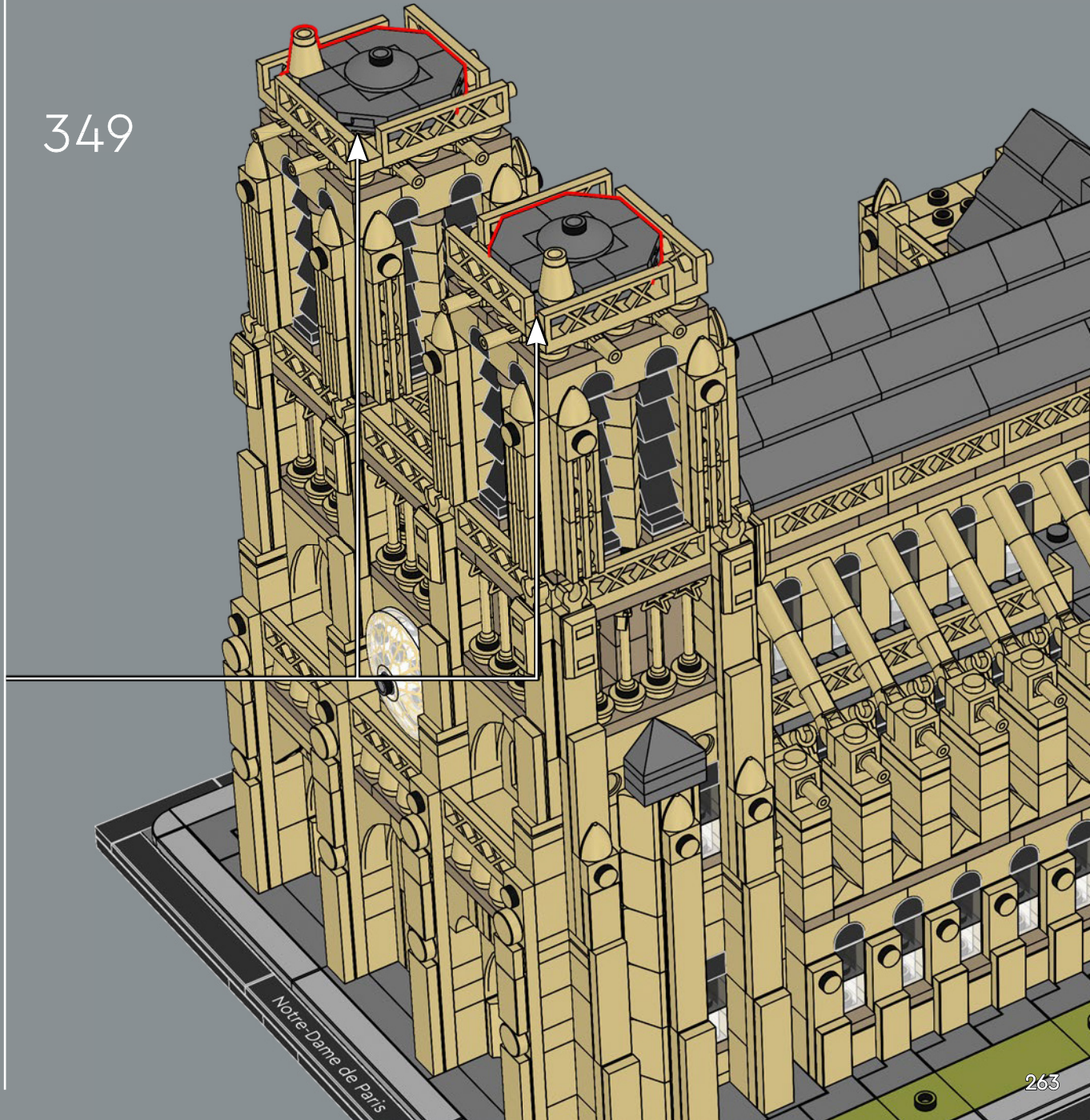

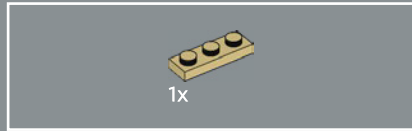
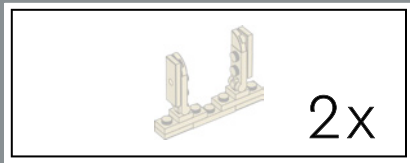

350

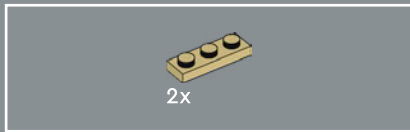
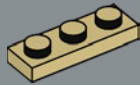

351

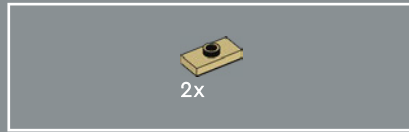
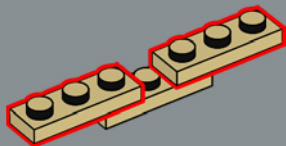

352

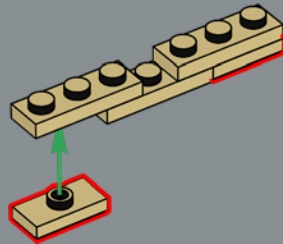

353

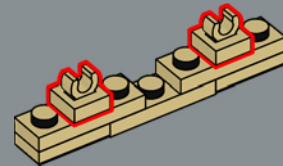

354

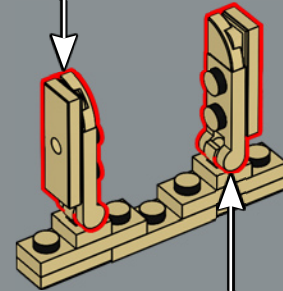
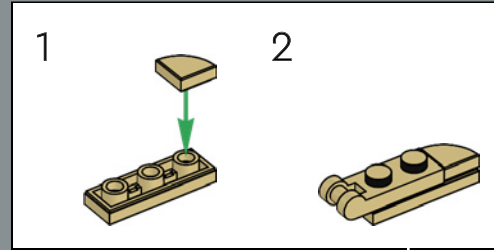

2x

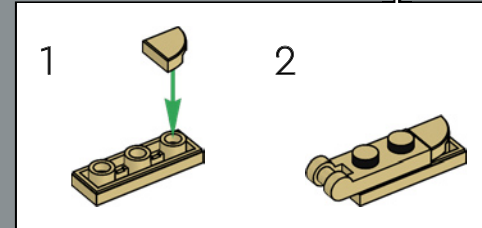



355



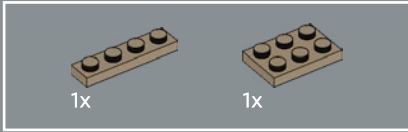

356

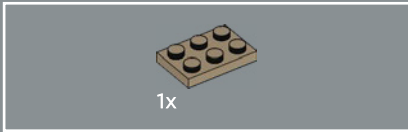
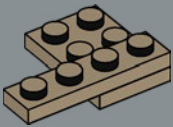

357

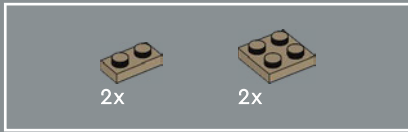
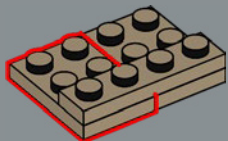

358

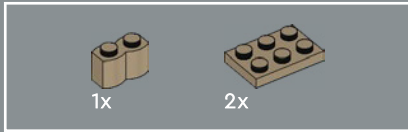
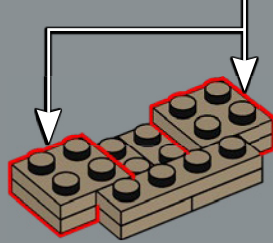
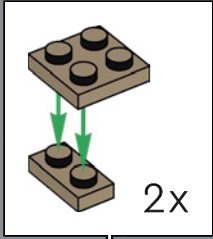

359

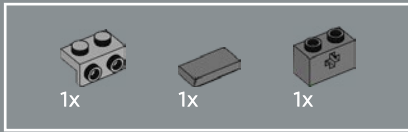
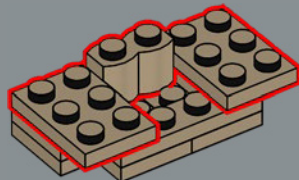

360

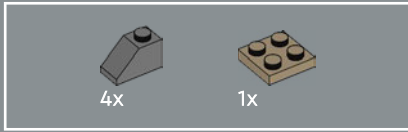
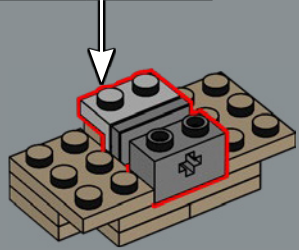
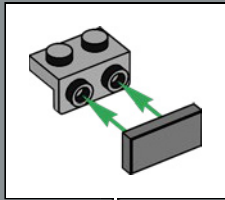

361

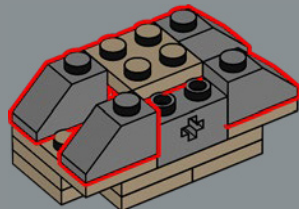

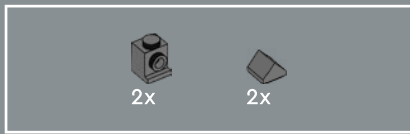

362

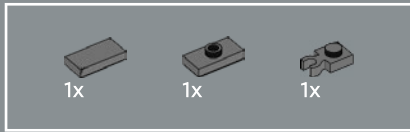
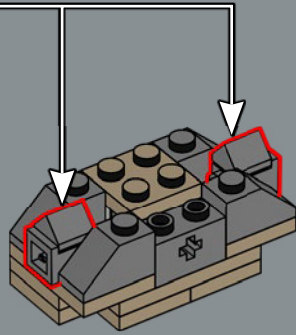
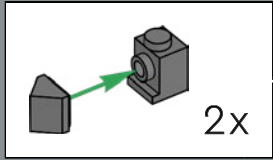

363

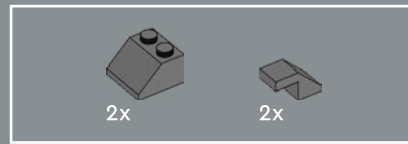
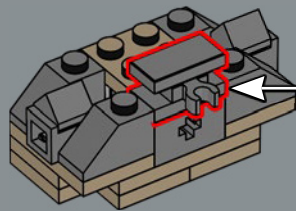
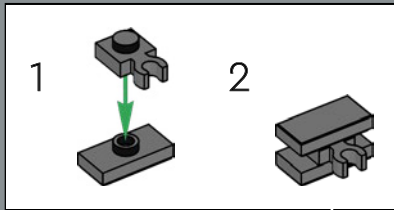

364

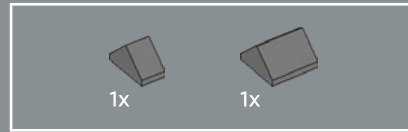
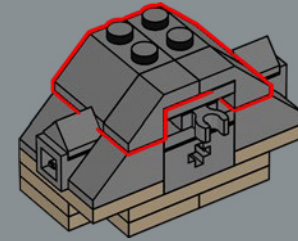

365

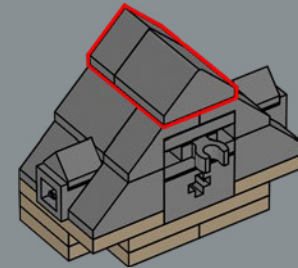



366

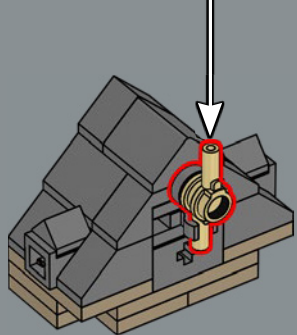
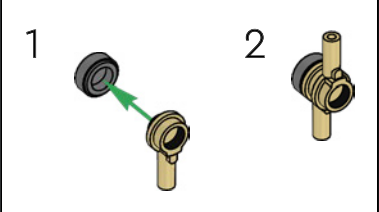

367

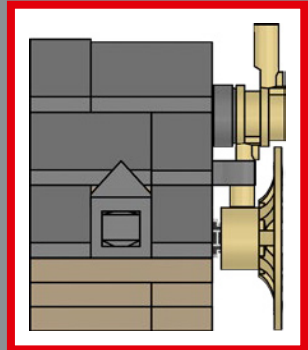
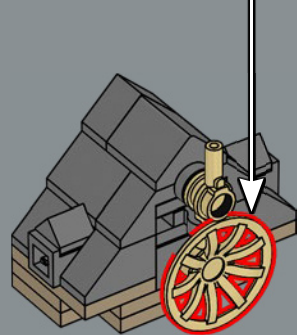
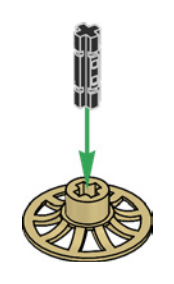

Die kleineren Rosenfenster werden mithilfe von  
LEGO® Radkappen dargestellt.

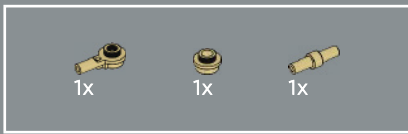

368

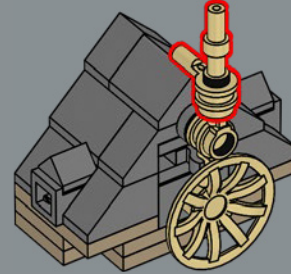
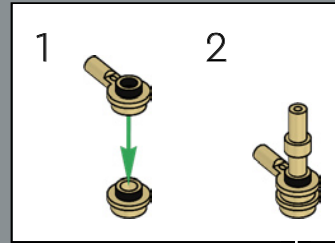

2x

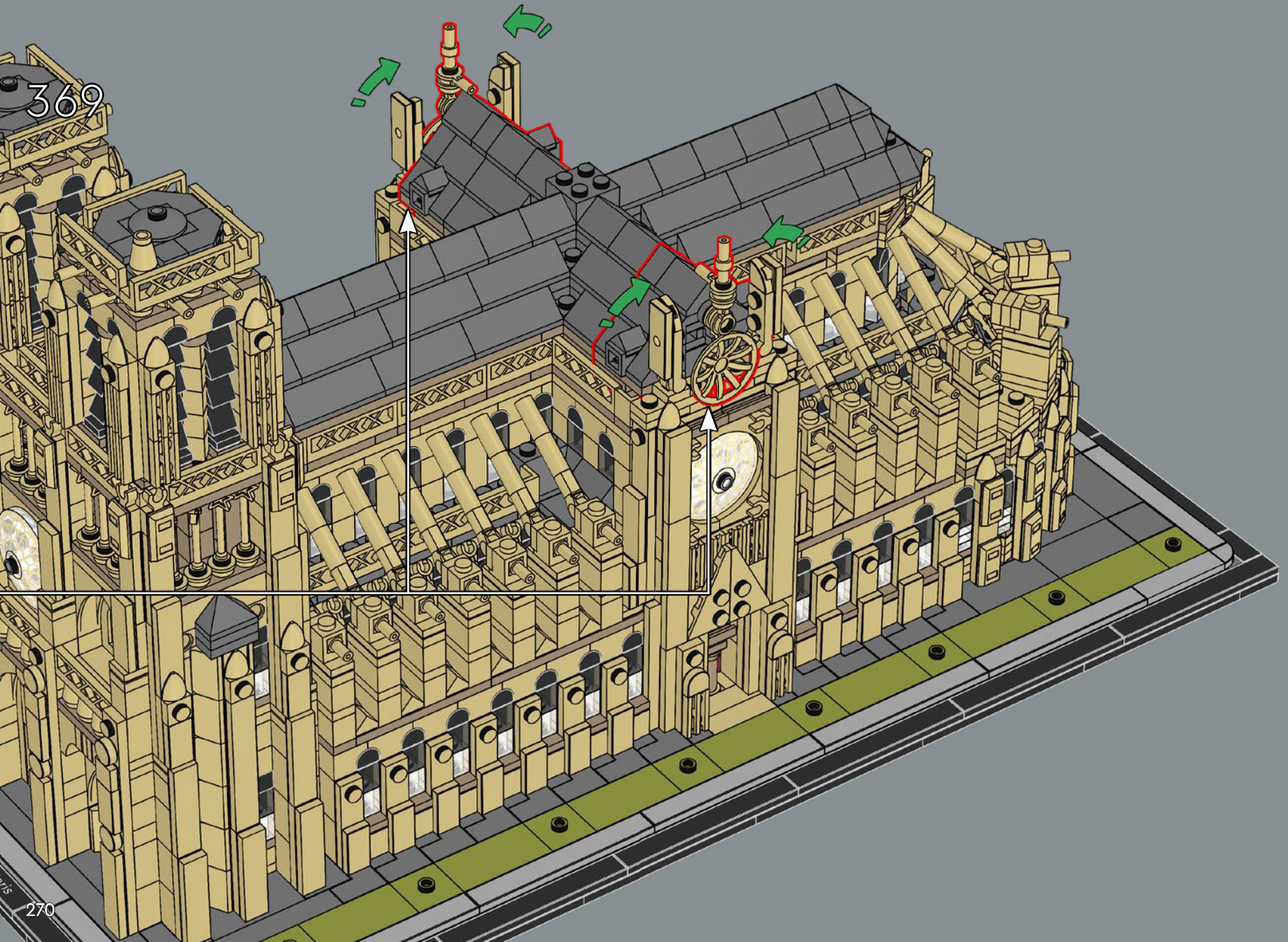

369

270

1245: Es werden weitere Modifikationen vorgenommen, und entlang des Hauptschiffs werden Seitenkapellen hinzugefügt.

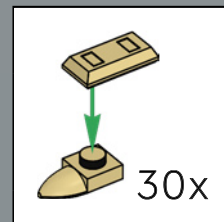
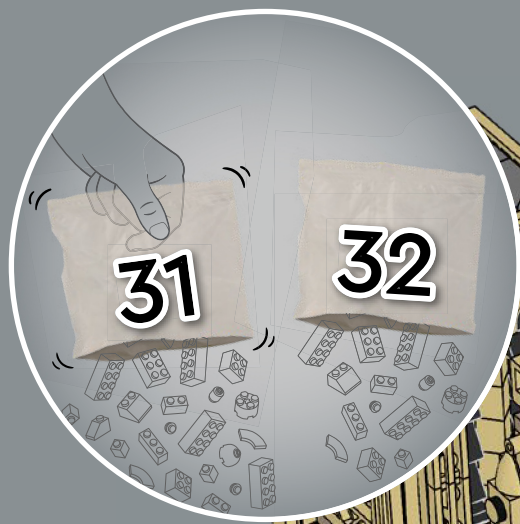

1789-1860



## REVOLUTION UND KULTURELLES ERBE

☩ Während der turbulenten Jahre der Französischen Revolution (1789–1799) erlitt die noble Kathedrale Notre-Dame Schäden und allmählichen Zerfall. Fenster, Altare und Gruften wurden zerstört, und die Glocken wurden zerlegt und eingeschmolzen. Im Jahr 1792 rissen Aufständische nicht nur die Statuen aus der Königsgalerie nieder, sondern auch den Vierungsturm. Vorübergehend wurde die Kathedrale sogar als Lager für Weine und andere Güter genutzt. Doch nach der Revolution entwickelte sich nicht nur ein immer größeres Bewusstsein für das französische Nationalerbe, sondern auch eine zunehmende Wertschätzung. Die Veröffentlichung von Victor Hugos *Der Glöckner von Notre-Dame* (1831) und die breite internationale Anerkennung dieses literarischen Werks untermauerten den Status der Kathedrale als kulturelles Juwel der Weltgeschichte. Von 1843 bis 1860 leiteten die Architekten Jean-Baptiste Lassus und Eugène-Emmanuel Viollet-le-Duc die umfassende Restaurierungskampagne und erschufen die uns heute bekannte Version des historischen Wahrzeichens.





371

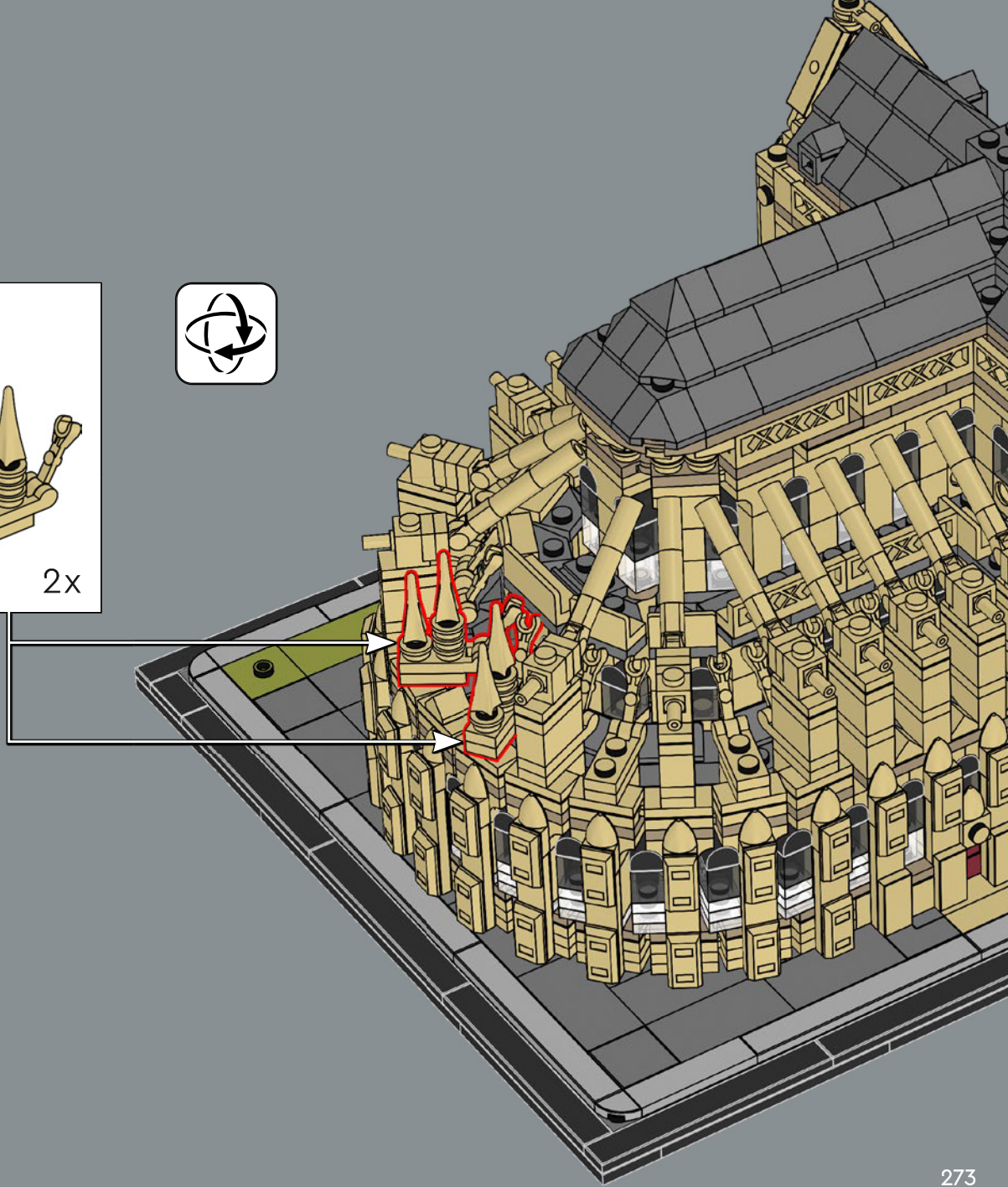
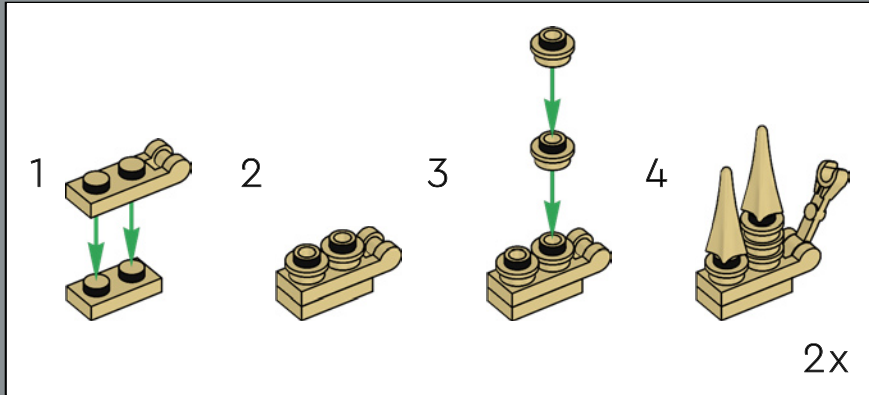



372

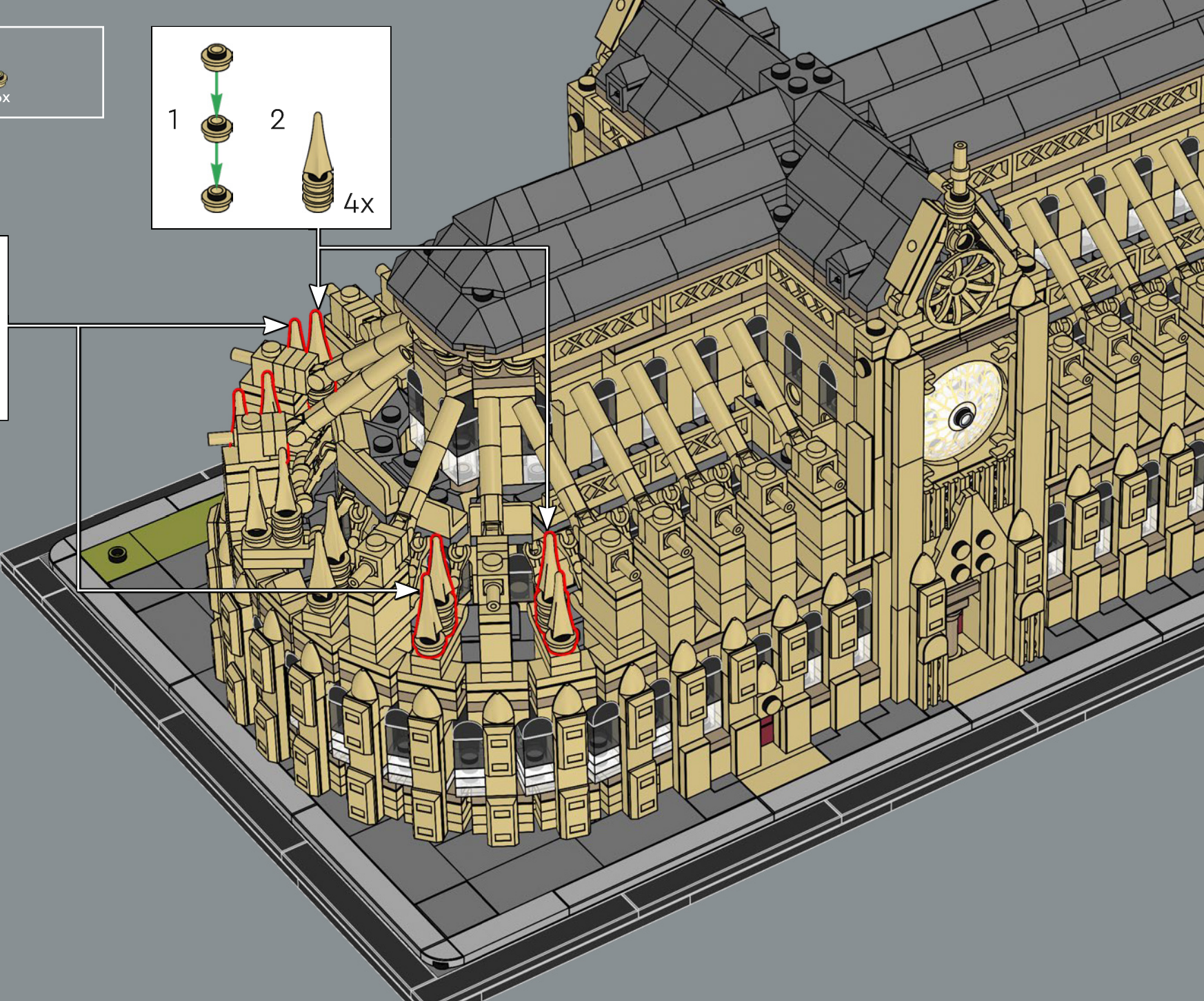
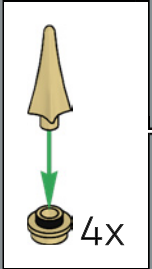
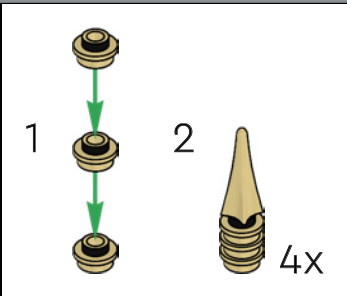



14x



28x

1350: Die Notre-Dame hat jetzt auch den letzten Feinschliff erhalten.  
Die Strebepeiler der Chors wurden erneuert und dann im 19.  
Jahrhundert erneut ausgetauscht.

373

1



2



14x

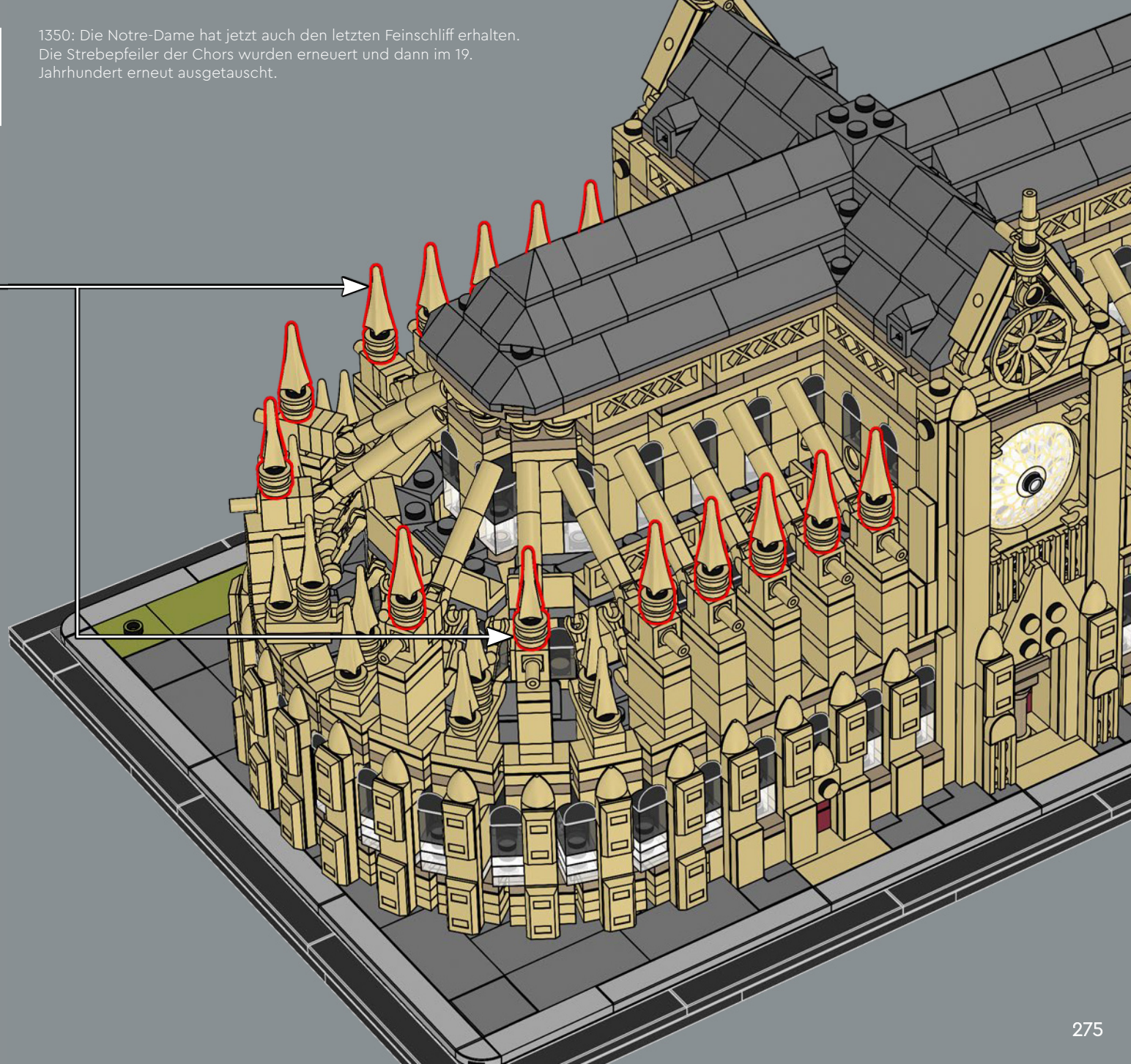



374

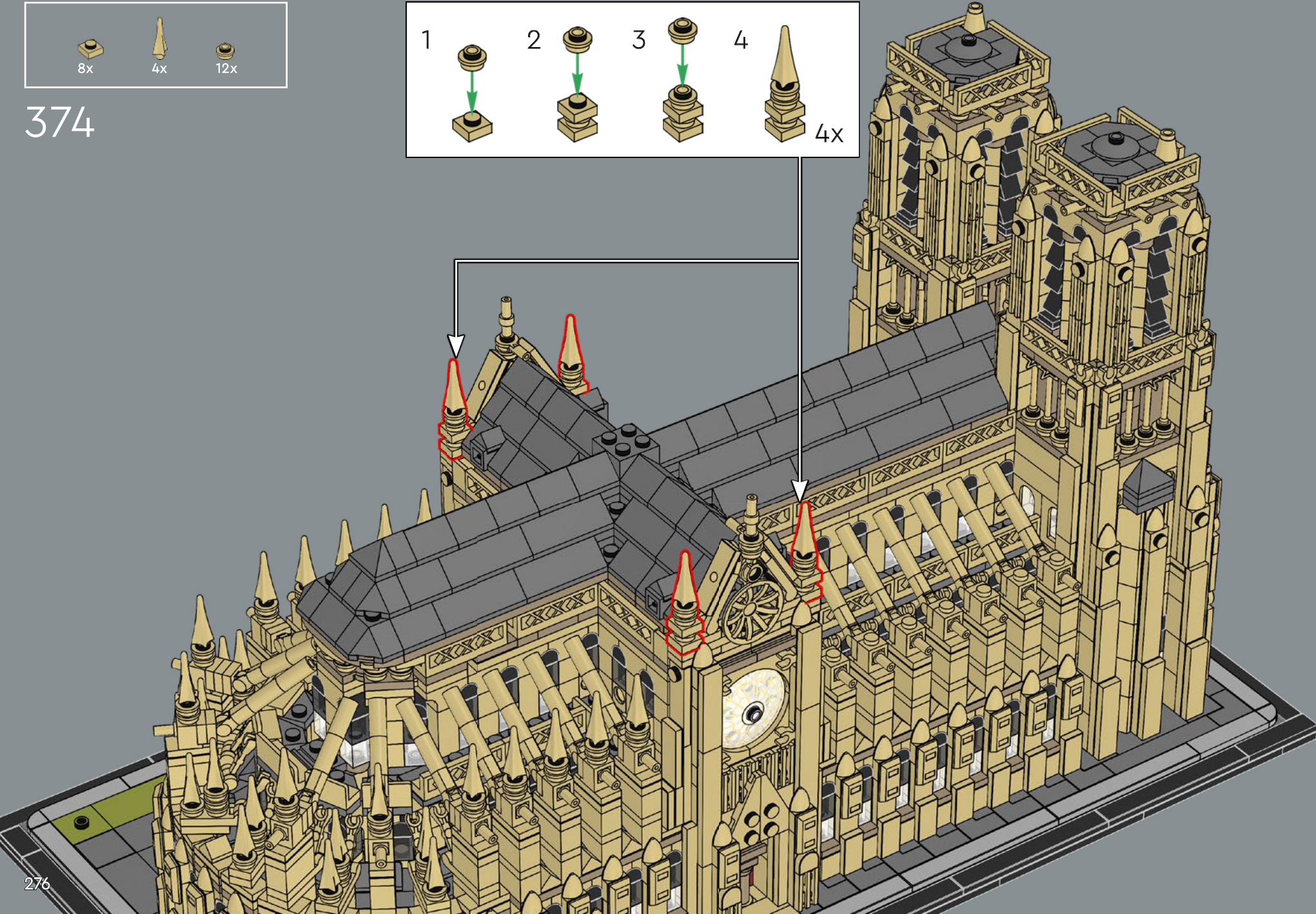
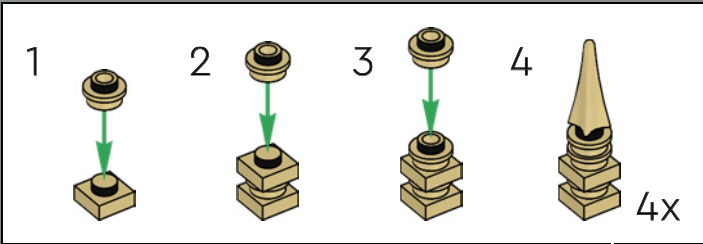



14x



14x

1858: Die Tabernakel an den Strebebögen werden von Jean-Baptiste Lassus and Eugène-Emmanuel Viollet-le-Duc hinzugefügt.

375



14x

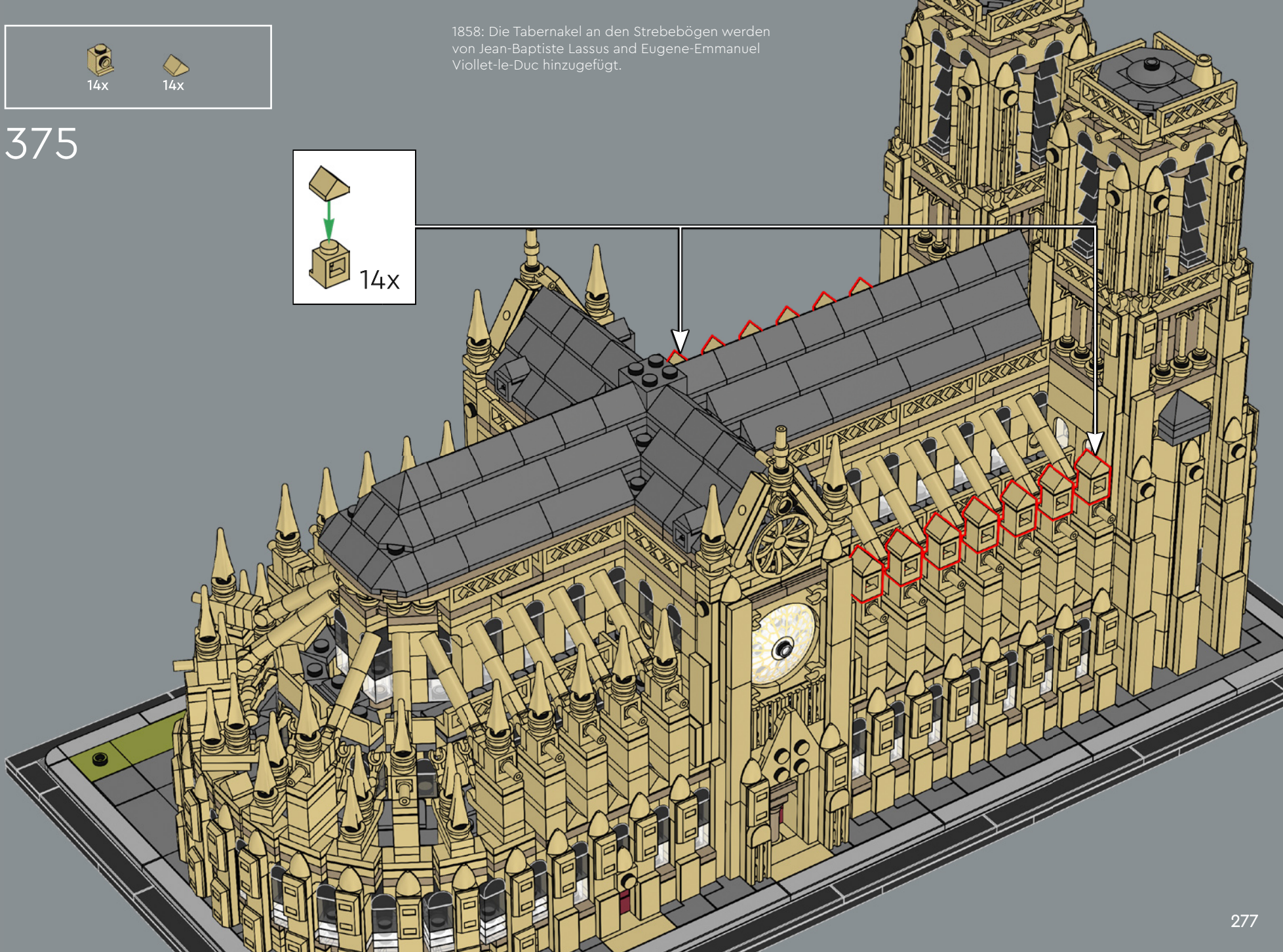

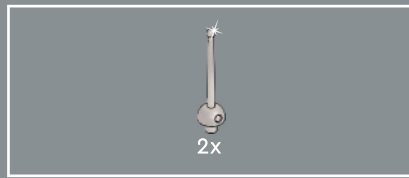

376

Die beiden 69 Meter hohen Türme an der Westfassade machten die Kathedrale Notre-Dame zum höchsten Gebäude von Paris, bis 1889 der Eiffelturm errichtet war.

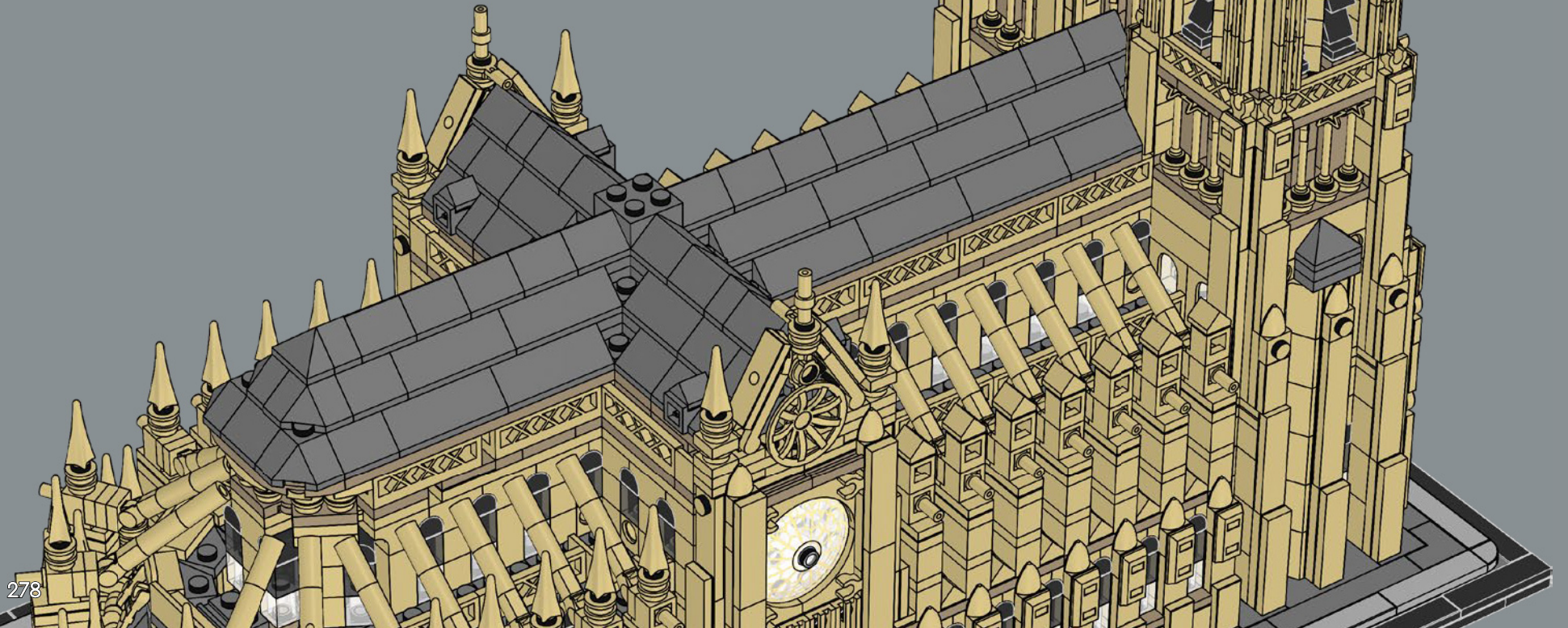



8x

# 377

1843–1860: Große Restauration durch Jean-Baptiste Lassus und Eugène-Emmanuel Viollet-le-Duc.

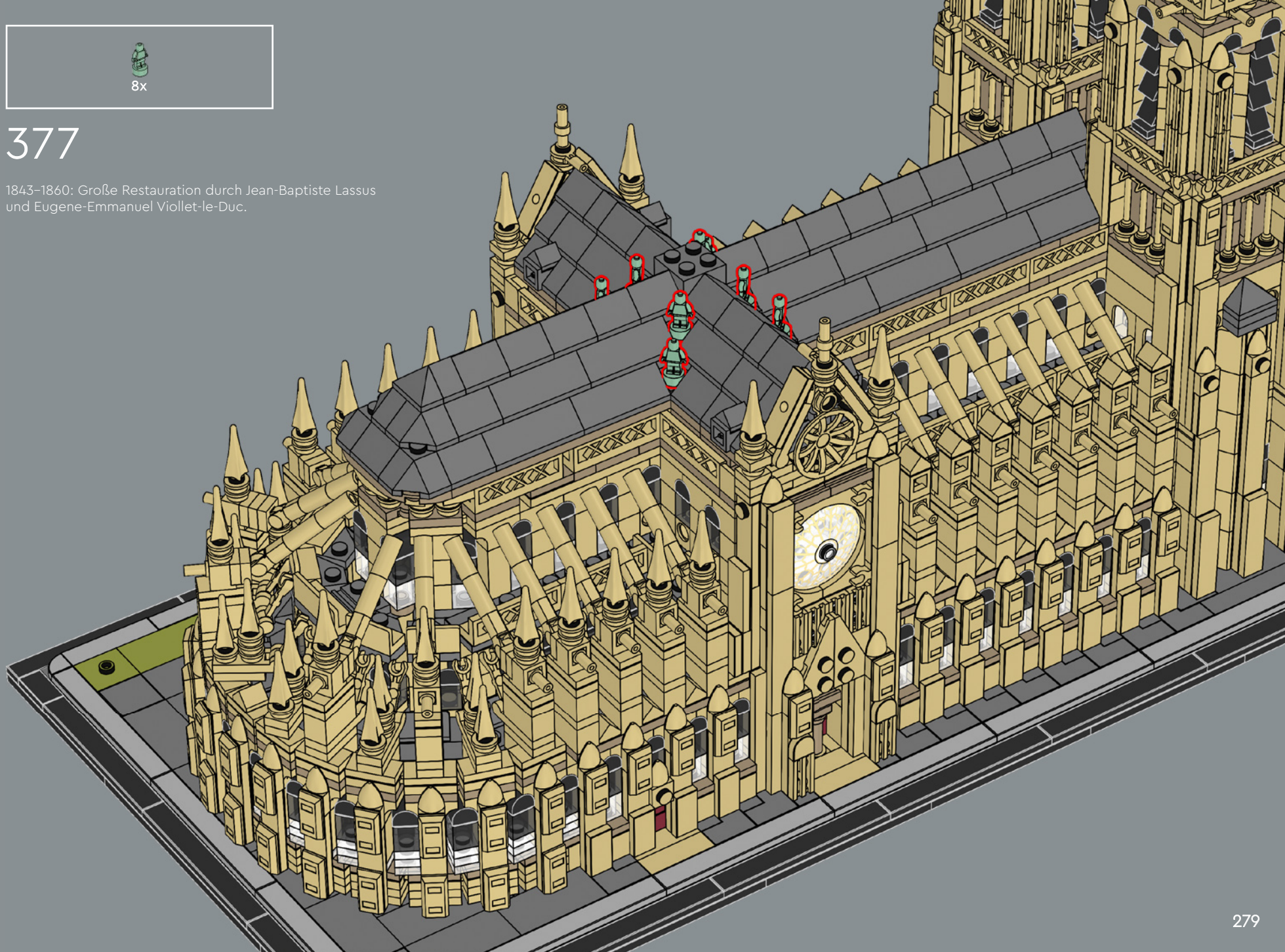



- 2x 
- 1x 
- 1x 
- 8x 

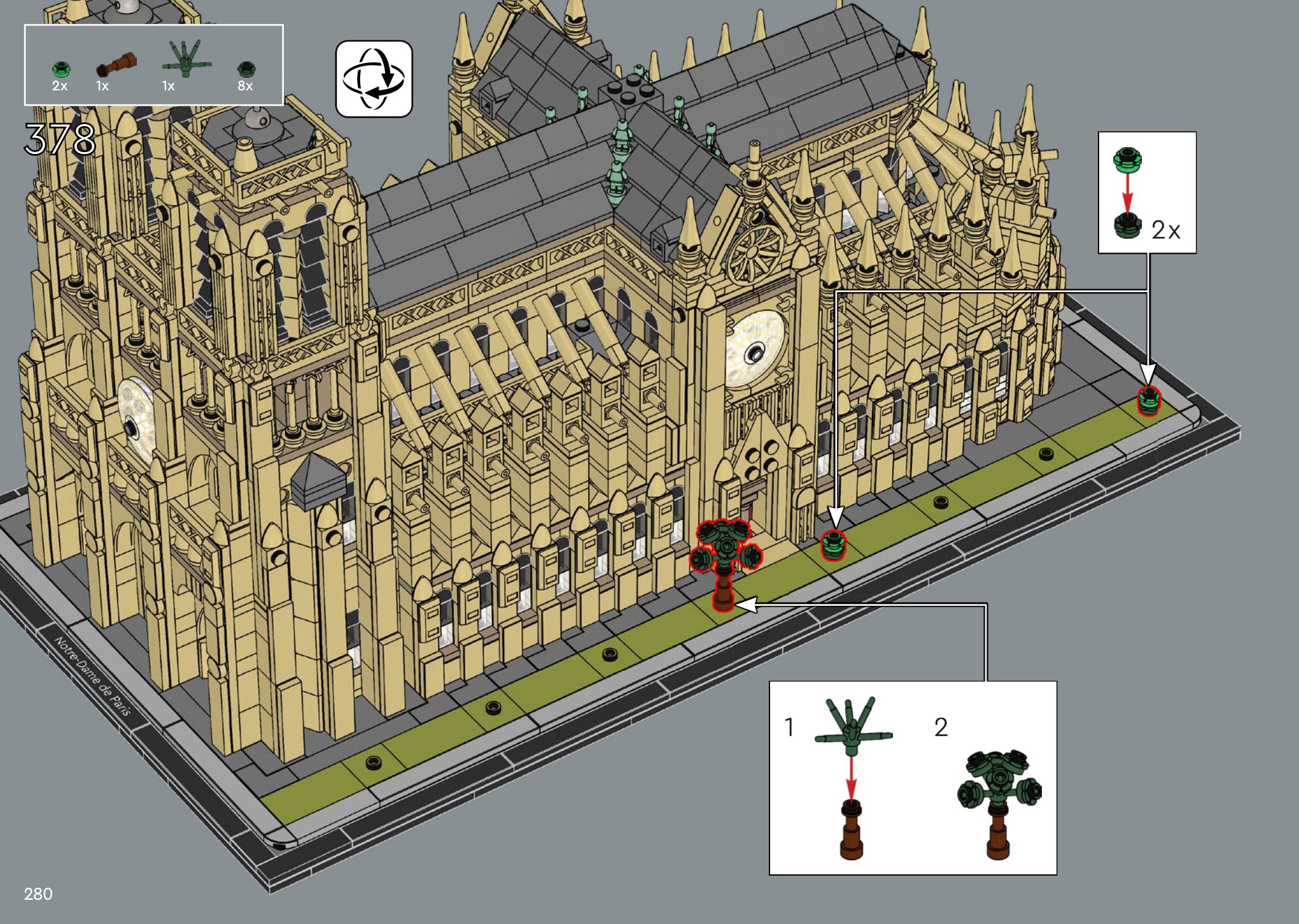
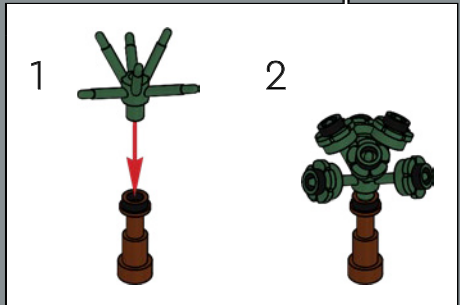
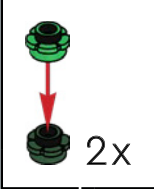

378









 18x
  3x
  3x

379



1 
 2 



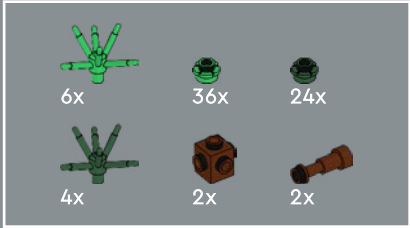
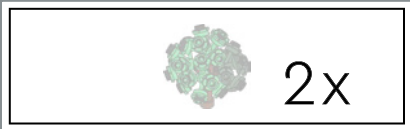

3x

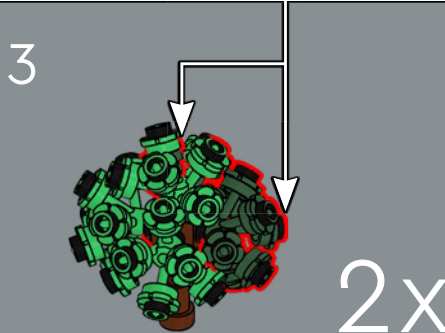
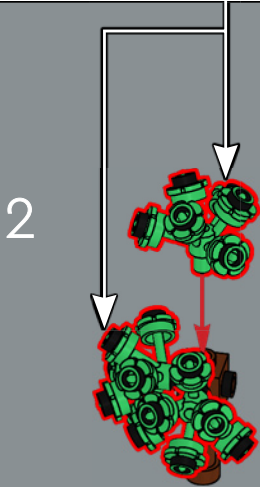
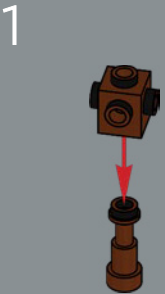
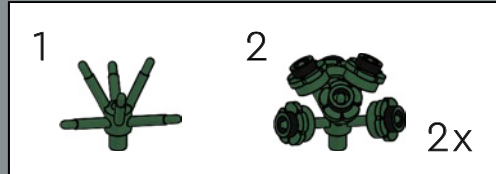
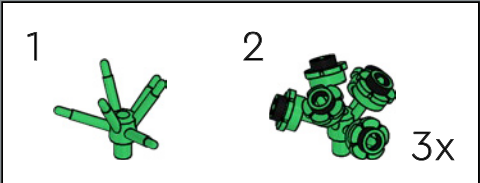

Aktuelle Abmessungen der Kathedrale Notre-Dame: Breite der Fassade: 43,5 Meter. Breite des Querschiffs: 48 Meter. Gesamtlänge: 128 Meter. Höhe des Vierungsturms: 96 Meter. Höhe der beiden Türme: 69 Meter. Höhe des Dachs des Hauptschiffs: 35 Meter.

380





Notre-Dame de Paris

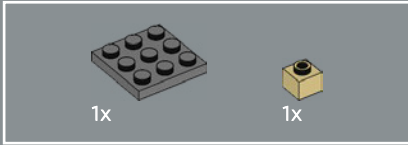
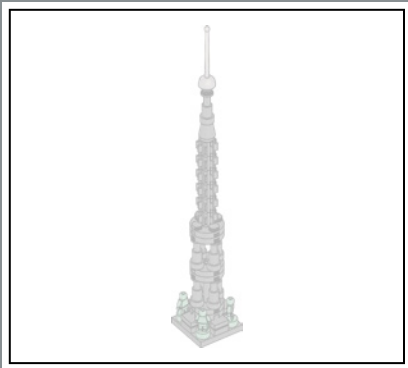

381

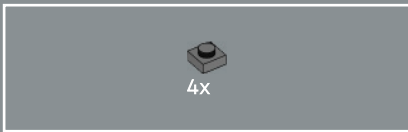
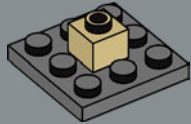

382

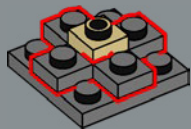

383

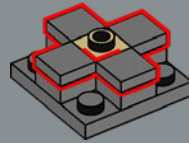

384

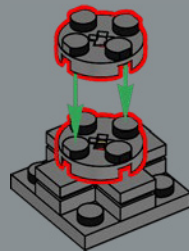

385

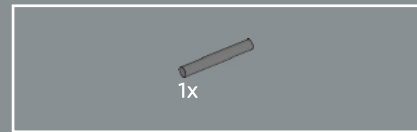
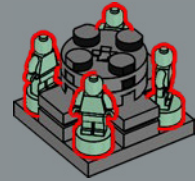

386

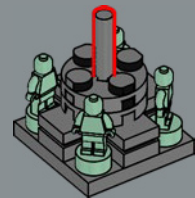



387

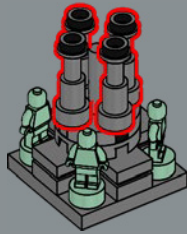

389

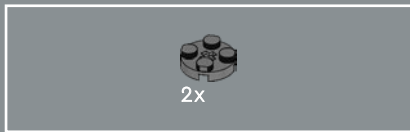
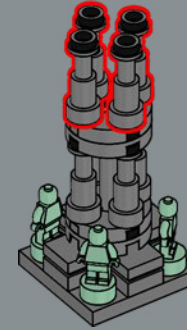

388

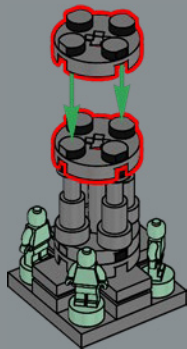

390

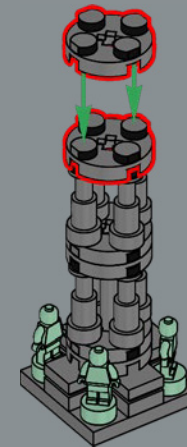

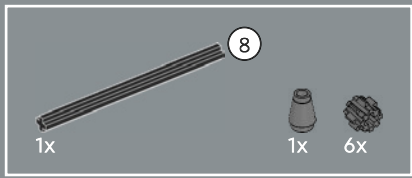

391

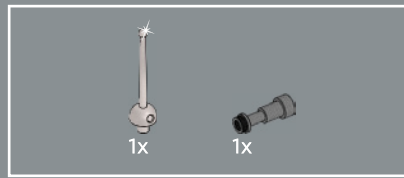
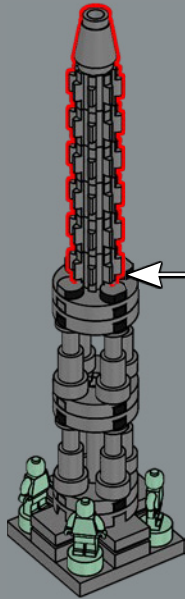
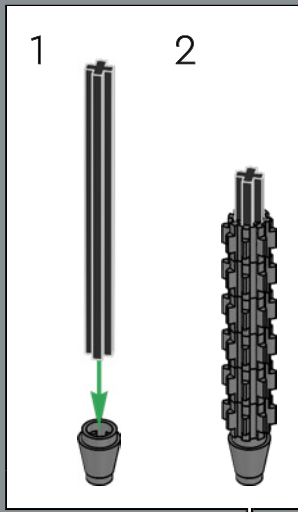

392

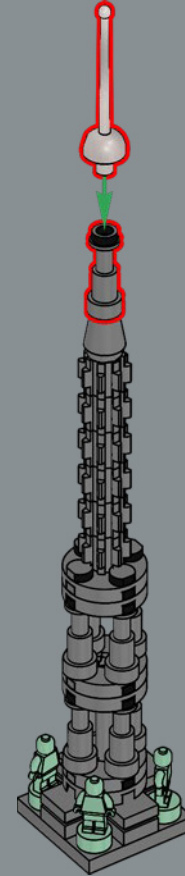

1860: Der Vierungsturm wird wieder errichtet, ist jetzt aber schlanker und höher als das Original. Entlang der Dachschräge werden zudem Skulpturen der 12 Apostel hinzugefügt.

Die vorderen Türen der LEGO® Kathedrale Notre-Dame de Paris sind offen, damit wir hineinblicken und die Ehrfurcht spüren können, die einen beim Betreten dieser riesigen und aufwendig gestalteten Kirche ergreift.

393

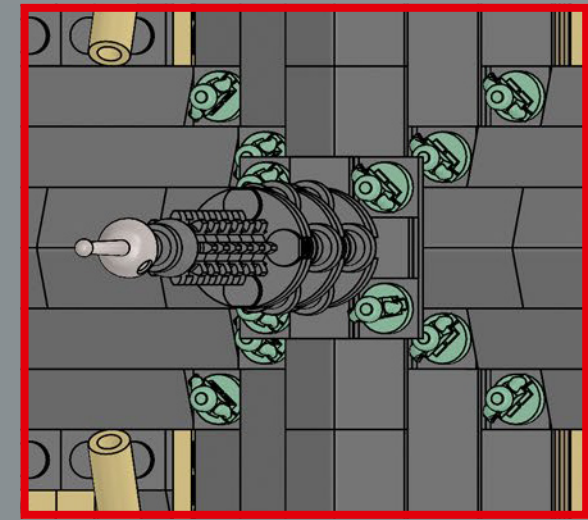
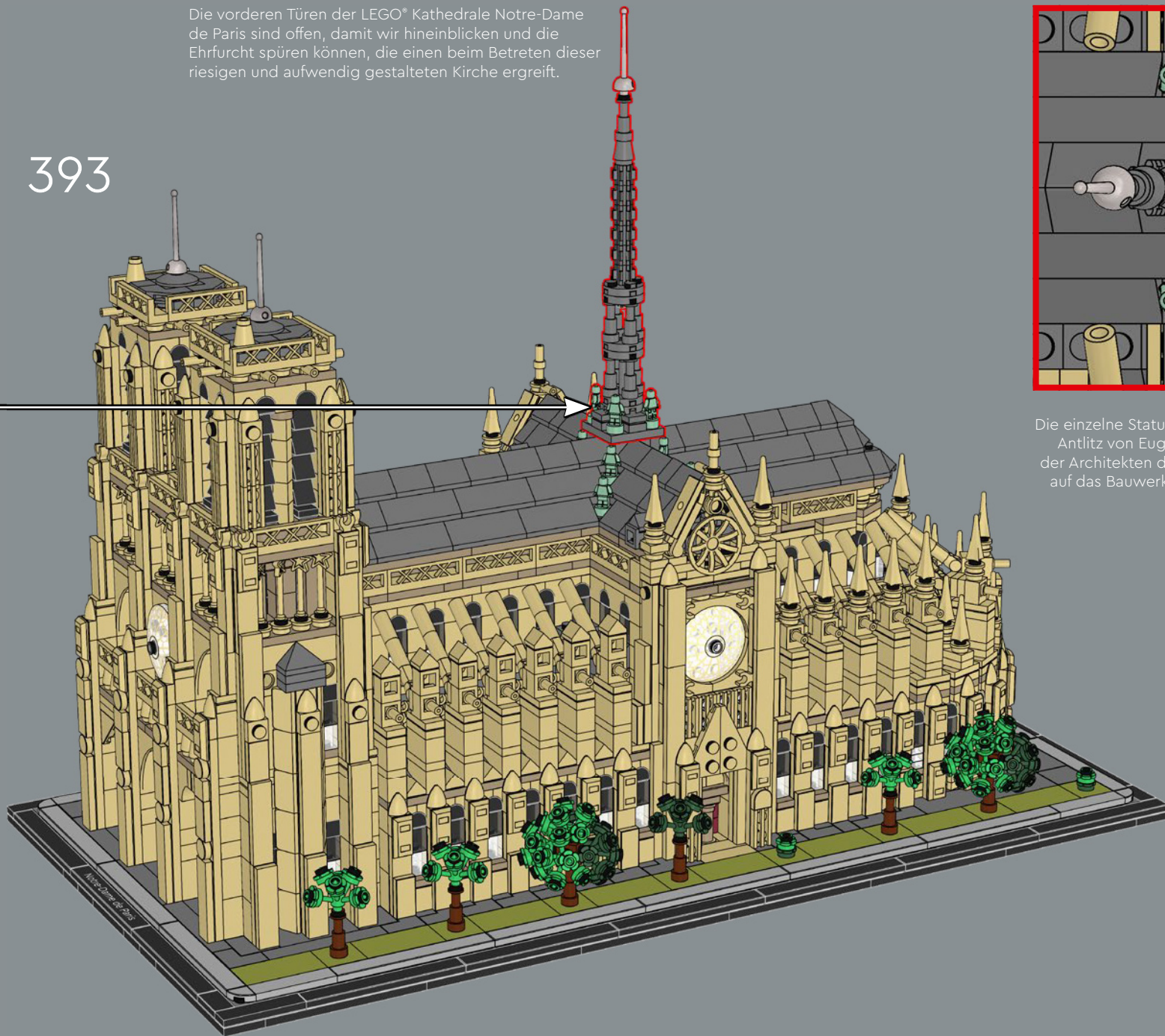

Die einzelne Statue, die zum Kirchturm blickt, ziert das Antlitz von Eugene-Emmanuel Viollet-le-Duc, einem der Architekten der Kathedrale. Er blickt bewundernd auf das Bauwerk, während die anderen Statuen über Paris wachen.



---

# DER WIEDERAUFBAU NACH DEM GROSSBRAND

☞ Nach dem verheerenden Großbrand im April 2019 musste die Kathedrale Notre-Dame wegen des anstehenden Wiederaufbaus auf unbestimmte Zeit ihre Pforten schließen. Noch während die ganze Welt den Feuerwehrleuten bei den Löscharbeiten zusah, liefen globale Spendenkampagnen an, die in Rekordzeit Riesensummen für einen Wiederaufbau einbrachten. Das ist ein eindeutiger Beleg dafür, welch nachhaltigen Eindruck die Kathedrale Notre-Dame bei den Menschen aus allen Kulturkreisen hinterlassen hat – und für den beispiellosen Geist von Paris. Mehr als 4.000 LEGO® Elemente bilden die fast 900-jährige Geschichte dieses Bauwerks nach. Es freut uns riesig, dass dieses Modell jetzt unsere LEGO Architecture Kollektion bereichert.







6x  
4616711



80x  
6300322



8x  
6231386



12x  
6449564



1x  
6167854



2x  
6300321



8x  
6458397



32x  
6446790



5x  
6398343



5x  
6264025



1x  
6341471



2x  
6133765



7x  
6428178



6x  
6310449



1x  
4211389



2x  
6267495



6x  
4211511



2x  
4213567



6x  
6383177



4x  
6401023



4x  
4211356



6x  
4211445

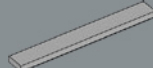

16x  
4211481



2x  
4654582



2x  
6469440



4x  
6176433



12x  
6335936



4x  
4211098



1x  
4211088



3x  
4211060



1x  
4211085



4x  
4211044



4x  
4558955



18x  
4535930



22x  
4211127



12x  
4210848



4x  
4210719



9x  
4211063



14x  
4211052



14x  
6092572



16x  
4210635



2x  
6126083



2x  
6309059



6x  
6177079



10x  
4211094



2x  
4211055



31x  
6247784



31x  
6343852



4x  
4568734



1x  
4211133



12x  
4211043



2x  
4211053



19x  
6039176



4x  
6307616



19x  
4560184



5x  
42110651



1x  
4243831



2x  
4210998



1x  
4211115



1x  
4211134



2x  
6296892



1x  
4543086



9x  
6284596



2x  
4210633



4x  
6221607



3x  
4210872



3x  
4210869



6x  
4211042



2x  
4211010



10x  
6164073



2x  
4527082



1x  
6310596



9x  
6396412



6x  
6012451



20x  
4211045



6x  
4218188

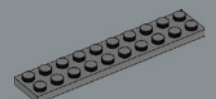

2x  
4210678

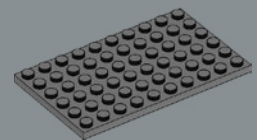

20x  
4211114



3x  
6222063



8x  
6212080



8x  
6016488



86x  
6470140



24x  
6446336

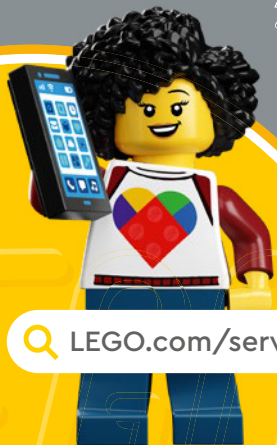

[LEGO.com/service](https://www.lego.com/service)



# YOU COULD WIN



## YOU COULD WIN

Your feedback will help shape the future development of this product series.

Visit:

## DU KÖNNTEST GEWINNEN

Dein Feedback trägt zur Weiterentwicklung dieser Produktreihe bei.

Geh auf:

## VOUS POURRIEZ GAGNER

Vos commentaires nous aideront à concevoir les futurs produits de cette gamme.

Visitez :

## POTRESTI VINCERE TU

La tua opinione ci aiuterà a migliorare la creazione futura di questa linea di prodotti.

Visita:

## PUEDES GANAR

Tu opinión contribuirá al futuro de esta serie de productos.

Visita:

## 轻松获奖

您的反馈将有助于我们在今后改进本产品系列。

请访问:

---

**[LEGO.com/productfeedback](https://LEGO.com/productfeedback)**

---

You also have the chance to win a LEGO® set.

Terms and conditions apply.\*

Außerdem hast du die Chance, ein LEGO® Set zu gewinnen.

Es gelten die Teilnahmebedingungen.\*

Vous pourriez également gagner un ensemble LEGO®.

Des conditions s'appliquent.\*

Hai anche la possibilità di vincere un set LEGO®.

Termini e condizioni sono applicabili.\*

También tienes la oportunidad de ganar un set LEGO®.

Aplican términos y condiciones.\*

您还有机会赢取乐高®套装。

条款和条件适用。\*

\*[LEGO.com/productfeedback-terms](https://LEGO.com/productfeedback-terms)

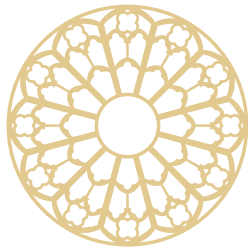

LEGO and the LEGO logo are trademarks of the LEGO Group. ©2024 The LEGO Group.  
Adam Reed Tucker is the co-developer of the LEGO® Architecture product line.