



THE FLINTSTONES™

21316



#024
LEGO
IDEAS





Meet the Fan Designer:

Originally from Manchester, England, US-based designer Andrew creates artwork for video games. In his free time, he creates art as well as photography. But his big passion is building LEGO® sets, both official ones and his own designs.

How and when did you get into building with LEGO® bricks?

I remember being amazed by all the details and working functions from my brother's 8860 Technic Car set, from around 1985. I liked to build cars, robots and spaceships. As with most LEGO fans, there was a period when other things took over, but around 2013, I got back into it and found LEGO CUUSOO, now known as LEGO Ideas.

What inspired you to make this Flintstones model?

I have fond memories of watching The Flintstones growing up, and even now as an adult I enjoy it. I wanted to bring those memories to life in a LEGO build that would be fun for kids, nostalgic for adults and would translate well into a LEGO set. I love how The Flintstones has most of the tech we have, such as a music player but done in a primitive way, such as a bird's beak playing the music disc, and the grass gets eaten, rather than cut!

What was the biggest design challenge with this model?

The design challenge with this set was capturing the fun and all the details of the show. It took about 88 hours in total and I used about 770 LEGO bricks in total, including Minifigures.

How did it feel reaching the 10,000 votes and then becoming the next LEGO Ideas set?

It took around 14 months to reach 10K and the support ebbed and flowed depending on how much time I spent promoting it. At 9996, I had to go to a meeting, but in my mind, I was yelling 'Yabba Dabba Doo!'

Andrew Clark

Fan Designer:

"The Flintstones is timeless, blocky, fun and colorful just like LEGO!"

Facts:

Favorite LEGO® elements:

- Studs Not On Top (SNOT)
- Brackets
- Micro Ball joints
- Curved slopes

More Facts:

LEGO Designers that inspire me:

Former LEGO Designer Adrian Florea:

He has some very creative parts usage on his Flickr.

Mike Psiaki:

He was official co-designer on the Saturn V and is a good technical builder.

Sam Johnson:

He did a great job taking my Doctor Who project and turning it into an official set.

Fan designers that inspire me:

Tyler Clites AKA Legohaulic:

Lots of cool fun models on his Flickr, and his Stitch model looks great.

Alex Jones AKA Orion Pax:

He has an amazing amount of cool models on his Flickr.

Jason Allemann AKA JK Brickworks:

He makes LEGO come alive through motion.

Websites I visit:

New Elementary:

In-depth blogs on new elements and creative ways to use them.

Brickset:

Lots of LEGO news updated daily.

Brothers Brick:

Cool and impressive builds.

Meet the LEGO® Designers:

Ricardo Silva

Yabadaba... DUH!! That was my reaction when asked to work on this project. Of course I wanted to! I had crossed my fingers for it to succeed when I saw this model popping up on LEGO® Ideas. The Flintstones were a big part of my childhood and I loved watching the cartoons on TV.

My job is to make sure the model is a good building experience, is stable during play and looks iconic, as well as ensure that we stay true to the fan's original vision in the model.

The entire model was impressive by itself, but I loved all the details that the fan designer, Andrew, had built in, including the car, the mailbox and the sofa, the TV set, the lamp and the phone. I tried to keep a lot of those in and even managed to add a few extra details.

One of the most challenging parts to improve was the roof of the house. It's a very big chunk of gray bricks and it lies at an angle, so it needed special attention.

It was a great collaboration and I'm very satisfied with how the model turned out.

Crystal "Bam" Fontan

I was ecstatic to have the opportunity to work on The Flintstones LEGO Ideas set!

I grew up with The Flintstones show so it was exciting to see how I could bring these characters to life in minifigure format! Bedrock is already colorful in itself, so I knew that there were some cool opportunities to bring color into the design.

The challenge was figuring out how to merge the animated style of The Flintstones with the LEGO style. The fan designer, Andrew, is a very passionate LEGO fan so it was very important to make his dream come true. He had great suggestions and was a great help!

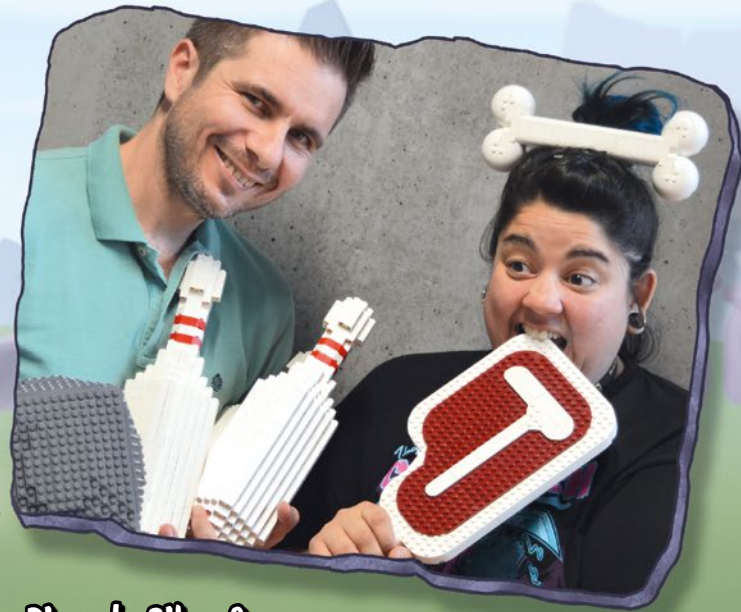

Ricardo Silva & Crystal "Bam" Fontan

LEGO Designers

It was definitely challenging creating the minifigures for The Flintstones characters. I mean... how do you make them without their iconic noses?! I think we achieved a great solution and it was an honor to bring these characters to life as LEGO minifigures.

My favorite part of the model is the tiger print curtain decoration! The color combo of the gray house, blue door and orange curtains truly ROCKS! ;)

About The Flintstones:

On September 30, 1960, Fred and Wilma Flintstone hit the television sets of America during prime time, depicting a fantasy Stone Age couple dealing with the dilemmas and issues of the modern era. Although initially panned by TV critics, it quickly became a hit; a funny, happy cartoon with large cross-generational appeal, so both adults and children could enjoy watching it together.

The humor was largely based on the juxtaposition of everyday dilemmas in this Stone Age setting, where a mid-century suburban American lifestyle was creatively appropriated with the 'technology' of the time; cars were powered by running humans, and domestic appliances such as washing machines, vacuum cleaners and garbage disposals worked via animals. In the town of 'Bedrock', items such as a radio or even a television set were made from... rocks. The two families of the show, the Flintstones and the Rubbles, did all the things a typical family would do like playing golf, bowling, playing pinball, using the telephones and listening to records, but they also had a pet dinosaur...

This LEGO® Flintstones set has been created in homage to the television classic, paying respect to the creativity, fun and humor of the show. We hope you enjoy it as much as we do.



Did you know...

The Flintstones were originally called the Flagstones and then the Gladstones. Bedrock was referred to in early episodes as Rockville.

The Flintstones was the most financially successful animated series, until The Simpsons.

Wilma Flintstone's maiden name was Wilma Slaghoopal and Betty Rubble's was Betty Jean McBricker.

The Flintstones episodes dealt with everyday issues of the time, some more serious than others. One story arc dealt with the Rubbles' difficulty having a child, but ended happily with the adoption of Bamm-Bamm.

Bio Facts:

Fred dreams of the day he can leave his dino operator job at the quarry and live in wealth and luxury.

Wilma and her best friend, Betty Rubble, sometimes take off on crazy escapades. Luckily, Wilma's practicality usually prevails and prevents the two women from getting into real trouble.

Barney is the devoted husband to Betty and father to Bamm-Bamm, and despite all his skirmishes with Fred, a loyal friend.

Quieter than Wilma, Betty Rubble nonetheless has a spark of mischievousness and loves her best friend's sense of adventure.

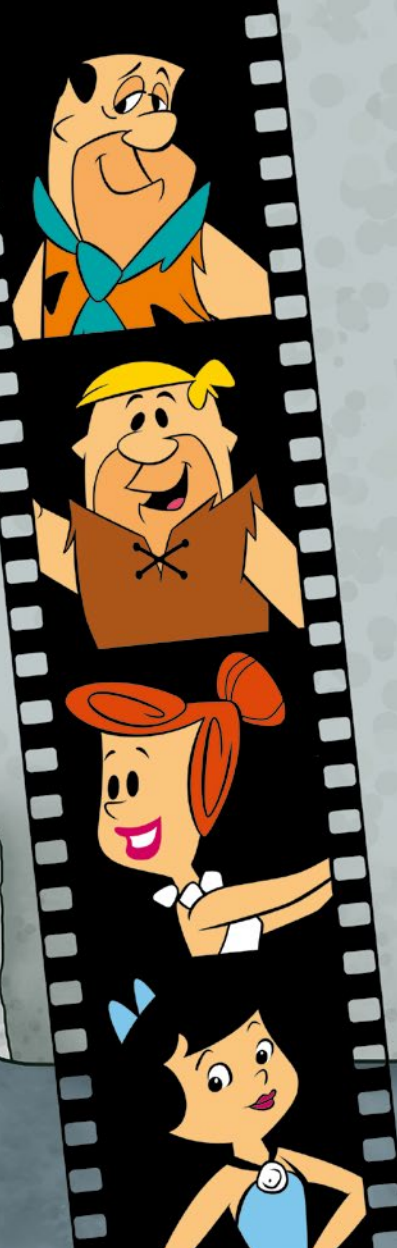



Rencontre avec le concepteur amateur

Andrew, concepteur installé aux États-Unis et originaire de Manchester, en Angleterre, crée des illustrations pour jeux vidéo. Dans ses temps libres, il s'adonne à l'art et à la photographie. Mais sa grande passion est la construction d'ensembles LEGO®, tant officiels qu'issus de ses propres conceptions.

Quand et comment avez-vous commencé à assembler des briques LEGO® ?

Je me souviens d'avoir été émerveillé par tous les détails et toutes les caractéristiques fonctionnelles de l'ensemble de voiture Technic 8860 de mon frère, qui datait de 1985 environ. J'aimais construire des voitures, des robots et des vaisseaux spatiaux. Comme pour la plupart des amateurs de LEGO, il y a eu un moment où je me suis intéressé à d'autres choses, puis, vers 2013, je suis revenu à mon ancienne passion et j'ai découvert LEGO Cuusoo, maintenant connu sous le nom de LEGO Ideas.

Qu'est-ce qui vous a inspiré pour réaliser ce modèle des Pierrafeu ?

J'ai de très bons souvenirs des Pierrafeu que je regardais étant enfant, et aujourd'hui encore, en tant qu'adulte, j'aime cette émission. J'ai voulu redonner vie à ces souvenirs grâce à une construction LEGO qui serait amusante pour les enfants, nostalgique pour les adultes, et qui correspondrait bien au contenu d'un ensemble LEGO. J'aime le fait que les Pierrafeu maîtrisent la majorité des technologies que nous avons, mais de manière primitive, par exemple un lecteur de disque utilisant le bec d'un oiseau comme tête de lecture, ou le gazon qui est mangé plutôt que coupé !

Quel a été le plus grand défi de conception pour ce modèle ?

Le défi de conception de cet ensemble a été de recréer le plaisir que procure l'émission et la foule de détails qu'elle contient. Il a fallu environ 88 heures au total et j'ai utilisé environ 770 briques LEGO, figurines comprises.

Qu'avez-vous ressenti en atteignant les 10 000 votes et lorsque votre création est ainsi devenue le prochain ensemble LEGO Ideas ?

Il a fallu environ 14 mois pour atteindre les 10 000 votes, et le soutien variait en fonction du temps que je passais à promouvoir ma conception. Arrivé à 9 996, je devais aller à une réunion, mais intérieurement, je criais « Yabba Dabba Dou ! ».

Andrew Clark

Concepteur amateur

« Les Pierrafeu sont intemporels, astucieux, amusants et colorés, tout comme LEGO ! »

Faits :

Éléments LEGO® préférés :

- Briques dont les tenons ne sont pas sur le dessus (SNOT)
- Supports
- Joints à rotule micro
- Pentecourbées

Plus de faits :

Concepteurs LEGO qui m'inspirent :

L'ancien concepteur LEGO Adrian Florea :

Il fait preuve de beaucoup d'imagination dans l'utilisation des pièces, comme on le voit sur son site Flickr.

Mike Psiaki :

Il a participé à la conception de Saturn V et est un bon constructeur technique.

Sam Johnson :

Il a fait un excellent travail en transformant mon projet Doctor Who en un ensemble officiel.

Concepteurs amateurs qui m'inspirent :

Tyler Clites, alias Legohaulic :

Son site Flickr présente beaucoup de modèles cool et amusants, et son modèle de Stitch a l'air génial.

Alex Jones, alias Orion Pax :

Il a une quantité incroyable de modèles cool sur son site Flickr.

Jason Allemann, alias JK Brickworks :

Il donne vie aux modèles LEGO par le mouvement.

Sites Web que je visite :

New Elementary :

Des billets de blogue pointus sur les nouveaux éléments et les façons créatives de les utiliser.

Brickset :

Beaucoup de nouvelles sur LEGO, mises à jour quotidiennement.

Brothers Brick :

Des constructions cool et impressionnantes.

Rencontre avec les concepteurs LEGO® :

Ricardo Silva

Yabadaba... DOU ! Ça a été ma réaction quand on m'a demandé de travailler sur ce projet. Bien sûr que je voulais ! J'avais croisé mes doigts pour qu'il réussisse quand j'ai vu ce modèle apparaître sur LEGO® Ideas. Les Pierrafeu ont occupé une grande place dans mon enfance, et j'ai aimé regarder ces dessins animés à la télévision.

Mon travail consiste à m'assurer que le modèle offre une bonne expérience de construction, est stable pendant le jeu et a un aspect emblématique, mais aussi de veiller à ce qu'il reste fidèle à la vision originale du fan.

L'ensemble du modèle était impressionnant en soi, mais j'ai aimé tous les détails que le concepteur amateur, Andrew, avait construits, y compris la voiture, la boîte aux lettres, le canapé, le téléviseur, la lampe et le téléphone. J'ai essayé de conserver un grand nombre de ces détails et j'ai même réussi à en ajouter quelques-uns.

Une des parties les plus difficiles à améliorer était le toit de la maison. C'est un très gros morceau de briques grises, et il forme un angle, donc il fallait y porter une attention particulière.

Ce fut une excellente collaboration, et je suis très satisfait de ce que le modèle est devenu.

Crystal « Bam » Fontan

J'ai été ravie d'avoir l'occasion de travailler sur l'ensemble LEGO Ideas des Pierrafeu !

J'ai grandi avec les Pierrafeu, alors il était intéressant de voir comment je pourrais donner vie à ces personnages sous la forme de figurines ! La ville de Saint-Granit est déjà colorée en soi, je savais donc qu'il y avait quelques bonnes occasions d'apporter de la couleur au modèle.

Le défi a été de déterminer comment fusionner le style animé des Pierrafeu avec le style LEGO. Le concepteur amateur, Andrew, est un fan de LEGO très passionné. Il était donc très important de réaliser son rêve. Il avait d'excellentes suggestions et a beaucoup aidé !



Ricardo Silva et Crystal « Bam » Fontan

Concepteurs LEGO

Ce fut véritablement difficile de créer les figurines des personnages des Pierrafeu. Je veux dire... Comment faire sans leurs emblématiques nez ?! Je pense que nous avons trouvé une excellente solution, et c'est un honneur de donner vie à ces personnages sous forme de figurines LEGO.

Ma partie préférée du modèle est le motif tigré des rideaux ! La combinaison du gris de la maison, du bleu de la porte et de l'orange des rideaux est vraiment géniale ! ;)

À propos des Pierrafeu :

Le 30 septembre 1960, Fred et Délima Caillou faisaient leur apparition sur les téléviseurs de l'Amérique, à l'heure de grande écoute, dépeignant un couple de l'âge de la pierre qui composait avec les dilemmes et les enjeux de l'ère moderne. Bien qu'initialement démoli par la critique, ce dessin animé est rapidement devenu un succès, acquérant une vaste popularité transgénérationnelle, de sorte que les adultes et les enfants le regardaient ensemble avec plaisir.

L'humour est fondé essentiellement sur la mise en scène des dilemmes quotidiens dans le cadre de l'âge de la pierre, où le mode de vie américain des banlieues a été recréé avec la « technologie » de l'époque. Les voitures sont propulsées par les pieds de leurs passagers, et les appareils ménagers, par exemple les laveuses, les aspirateurs et les broyeurs de déchets sont actionnés par des animaux. Dans la ville de Saint-Granit, des objets comme une radio ou même un téléviseur sont faits... en pierre. Les deux familles de l'émission, les Caillou et les Laroche, faisaient toutes les choses qu'une famille typique pouvait faire, comme jouer au golf, aux quilles ou au billard, utiliser des téléphones et écouter des disques, mais ils avaient aussi un dinosaure comme animal de compagnie...

Cet ensemble LEGO® Pierrafeu a été créé en hommage à ce classique de la télévision, à sa créativité, à son humour et au plaisir qu'il procure. Nous espérons que vous l'apprécierez autant que nous.



Le saviez-vous ?

Le titre de la version originale, les Flintstones, a d'abord failli être les Flagstones, puis les Gladstones. Dans les premiers épisodes américains, Saint-Granit (Bedrock) s'appelait Rockville.

Les Pierrafeu a été la série d'animation la plus rentable, jusqu'à l'arrivée des Simpson.

Le nom de jeune fille de Délima Caillou était Délima Galet.

Les épisodes des Pierrafeu traitaient de questions de l'époque, certaines plus graves que d'autres. Un des scénarios portait sur la difficulté des Laroche à avoir un enfant, mais se terminait de manière heureuse par l'adoption de Boum-Boum.

Faits biographiques :

Fred rêve du jour où il pourra quitter son emploi de conducteur de dinosaure à la carrière et vivre dans le luxe et l'opulence.

Délima et sa meilleure amie, Bertha Laroche, partent parfois dans de folles escapades. Heureusement, le sens pratique de Délima prévaut habituellement et évite aux deux femmes d'avoir de véritables ennuis.

Arthur est le mari dévoué de Bertha et le père de Boum-Boum et, malgré toutes ses querelles avec Fred, il est aussi un ami fidèle.

Plus discrète que Délima, Bertha Laroche a néanmoins une étincelle de malice et adore le sens de l'aventure de sa meilleure amie.

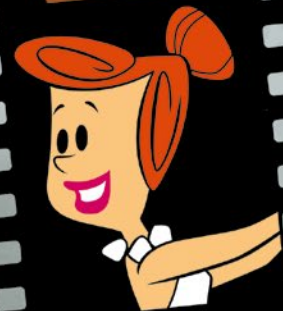



Andrew Clark

El fan diseñador:

“Los Picapiedra nunca pasan de moda, todo lo hacen con bloques y son una fuente de diversión y colores: ¡igual que LEGO!”.

Datos:

Elementos LEGO® favoritos:

- Bricks con espigas laterales
- Conectores angulares
- Uniones microesféricas
- Pendientes curvadas

Conoce al fan diseñador:

Originario de Manchester (Inglaterra), Andrew vive en Estados Unidos y diseña ilustraciones para videojuegos. Le gusta dedicar su tiempo libre tanto al arte como a la fotografía. Sin embargo, su gran pasión es construir modelos LEGO®, ya sean oficiales o diseñados por él mismo.

¿Cómo y cuándo empezaste a construir con bricks LEGO®?

Todavía recuerdo lo mucho que me asombraron los detalles y las funciones del set Technic Car (8860), que mi hermano construyó alrededor de 1985. Me gustaba construir autos, robots y naves espaciales. Como suele pasar cuando eres fan de LEGO, hubo un tiempo en el que preferí hacer otras cosas, pero, más o menos en el año 2013, me reencontré con mi antiguo pasatiempo y descubrí LEGO Cuusoo, que ahora se llama LEGO Ideas.

¿Qué te animó a crear este modelo de Los Picapiedra?

Recuerdo con cariño haber visto Los Picapiedra cuando era pequeño, e incluso ahora, de adulto, sigo disfrutando cuando los veo. Quería darles vida a esos recuerdos mediante un modelo LEGO que fuera divertido para los niños y nostálgico para los adultos, y que funcionara bien como set LEGO. Me encanta que los Picapiedra tengan casi toda la tecnología que tenemos nosotros, pero de una manera muy primitiva, como cuando usan el pico de un pájaro para reproducir un disco de música o un dinosaurio que se come la hierba en lugar de cortarla!

¿Cuál fue el mayor desafío al que te enfrentaste al diseñar este modelo?

Lo más complicado del proceso de diseñar este set fue capturar la diversión y los detalles del programa. Me tomó unas 88 horas y alrededor de 770 bricks LEGO en total, incluidas las minifiguras.

¿Cómo te sentiste cuando llegaste a los 10.000 votos y tu modelo se convirtió en el próximo set LEGO Ideas?

Me tardé unos 14 meses en llegar a los 10 K, y el apoyo que recibí subió y bajó según el tiempo que pasé promocionando la propuesta. Cuando tenía 9996 tuve que asistir a una reunión, pero dentro de mi cabeza no hacía más que gritar: “¡Yabba dabba doo!”.

Más datos:

Diseñadores de LEGO que me inspiran:

Adrian Florea (antigo diseñador de LEGO):
Usa algunas piezas de formas muy creativas y las muestra en su Flickr.

Mike Psiaki:
Fue el codiseñador oficial del Saturno V y es un buen constructor técnico.

Sam Johnson:
Hizo un gran trabajo convirtiendo mi proyecto del Doctor Who en un set oficial.

Fans diseñadores que me inspiran:

Legohaulic (Tyler Clites):
Tiene un montón de modelos divertidos en su Flickr y su modelo de Stitch es fantástico.

Orion Pax (Alex Jones):
Tiene una increíble cantidad de modelos geniales en su Flickr.

JK Brickworks (Jason Allemann):
Logra que sus modelos LEGO cobren vida mediante el movimiento.

Sitios web que visito:

New Elementary:
Blogs detallados sobre nuevos elementos y formas creativas de usarlos.

Brickset:
Montones de noticias sobre LEGO actualizadas a diario.

Brothers Brick:
Modelos geniales e impresionantes.

Conoce a los diseñadores de LEGO®:

Ricardo Silva

“¡Yabba dabba do!”. Así fue como reaccioné cuando me pidieron que trabajara en este proyecto. ¡Por supuesto que quería! Tenía la esperanza de que el modelo fuera elegido desde que lo vi aparecer en LEGO® Ideas. Los Picapiedra fueron parte importante de mi infancia y me encantaba ver dibujos animados en la tele.

Mi trabajo consistió en asegurarme de que el modelo representara una buena experiencia de construcción, fuera estable al jugar con él y conservara el inconfundible carácter de la serie, además de garantizar que fuera fiel a la visión original del fan que lo creó.

El modelo entero era ya de por sí impresionante, pero me encantaron los detalles que Andrew, el fan diseñador, había incorporado, como el auto, el buzón, el sofá, el televisor, la lámpara y el teléfono. Traté de conservar muchos de ellos e incluso me las arreglé para incluir algunos más.

Una de las partes más difíciles de mejorar fue el techo de la casa. Es un bloque muy grande de bricks grises y está inclinado, por lo que requirió atención especial.

Fue una magnífica colaboración y me siento muy satisfecho con el modelo tal como quedó.

Crystal “Bam” Fontan

¡Me alegró muchísimo tener la oportunidad de trabajar en el set LEGO Ideas Los Picapiedra!

Crecí viendo Los Picapiedra, así que fue apasionante descubrir cómo podría darles vida a los personajes en forma de minifigura. Piedradura es de por sí un lugar muy colorido, por lo que sabía que tendría buenas oportunidades de aportar color al diseño.

El desafío consistió en averiguar cómo combinar el estilo de dibujo animado de Los Picapiedra con el estilo de LEGO. El fan diseñador,



**Ricardo Silva y
Crystal “Bam” Fontan**

Los diseñadores de LEGO

Andrew, es un apasionado de LEGO, de modo que era muy importante hacer su sueño realidad. ¡Hizo excelentes sugerencias y fue de gran ayuda!

Fue todo un reto crear las minifiguras de los personajes de Los Picapiedra. O sea... ¡¿cómo podía hacerlos sin usar sus famosas narices?! Creo que encontramos una magnífica solución y fue un honor convertir a los personajes en minifiguras LEGO.

Mi parte favorita del modelo son las cortinas: ¡están decoradas como si fueran de piel de tigre! La combinación de colores que forman la casa gris, la puerta azul y las cortinas naranjas **NO TIENE COMPARACIÓN.** ;)

Acerca de Los Picapiedra:

El 30 de septiembre de 1960, Pedro y Vilma Picapiedra irrumpieron en los televisores de los estadounidenses en horario de máxima audiencia, retratando de manera imaginativa a una pareja de la Edad de Piedra que se enfrentaba a los dilemas e inconvenientes de la era moderna. Aunque, en un primer momento, no gustó demasiado a los críticos de televisión, el éxito fue casi inmediato; se trataba de una caricatura divertida y alegre con un gran atractivo intergeneracional, por lo que adultos y niños podían pasarla genial viéndola juntos.

En gran medida, el humor que proponía se basaba en la yuxtaposición entre los dilemas cotidianos de la época y el contexto de la Edad de Piedra, presentando el estilo de vida suburbano estadounidense de mediados de siglo creativamente equipado con “tecnología” adaptada a la prehistoria: los autos funcionaban con seres humanos que corrían, mientras que los electrodomésticos, como las lavadoras, las aspiradoras y las trituradoras de basura, funcionaban con animales. En la ciudad de Piedradura, los aparatos electrónicos, como los radios y los televisores, estaban hechos de... piedras. Las dos familias que protagonizaban el programa, los Picapiedra y los Mármol, hacían todo lo que hacía una familia normal, como jugar al golf, al boliche y a las maquinitas, usar el teléfono y escuchar discos de música, pero también tenían un dinosaurio como mascota!

El set LEGO® Los Picapiedra rinde homenaje al clásico de la televisión, respetando la creatividad, la alegría y el humor del programa. Esperamos que lo disfrutes tanto como nosotros.



¿Lo sabías?

En un principio, los Picapiedra (Flintstone, en inglés) se llamaron Flagstone; más tarde, también Gladstone. En los primeros episodios, se hacía referencia a Piedradura (Bedrock, en inglés) como Rockville.

Los Picapiedra fue la serie de animación de mayor éxito financiero hasta la llegada de Los Simpson.

En inglés, los apellidos de soltera de Vilma Picapiedra y Betty Mármol eran Slaghoopal y McBricker, respectivamente.

Los episodios de Los Picapiedra trataban temas cotidianos de la época, algunos más serios que otros. Uno de ellos abordaba la dificultad de los Mármol para tener un hijo; terminaba felizmente con la adopción de Bam-Bam.

Datos biográficos:

Pedro sueña con abandonar su trabajo como operador de dinosaurios en la cantera y vivir entre lujos y riquezas.

Vilma y su mejor amiga, Betty Mármol, se embarcan a veces en locas aventuras. Por suerte, casi siempre prevalece el sentido común de Vilma, que impide que las dos mujeres lleguen a meterse en verdaderos problemas.

Pablo es el fiel esposo de Betty y el padre de Bam-Bam; y, a pesar de sus pleitos con Pedro, también su amigo más leal.

Más reservada que Vilma, Betty Mármol tiene cierto carácter travieso y adora el sentido de la aventura de su mejor amiga.

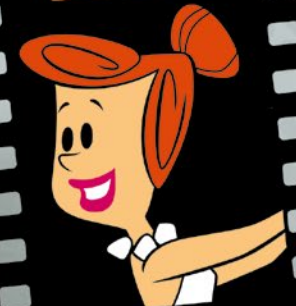

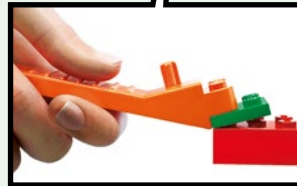

LEGO.com/brickseparator

1



2



3

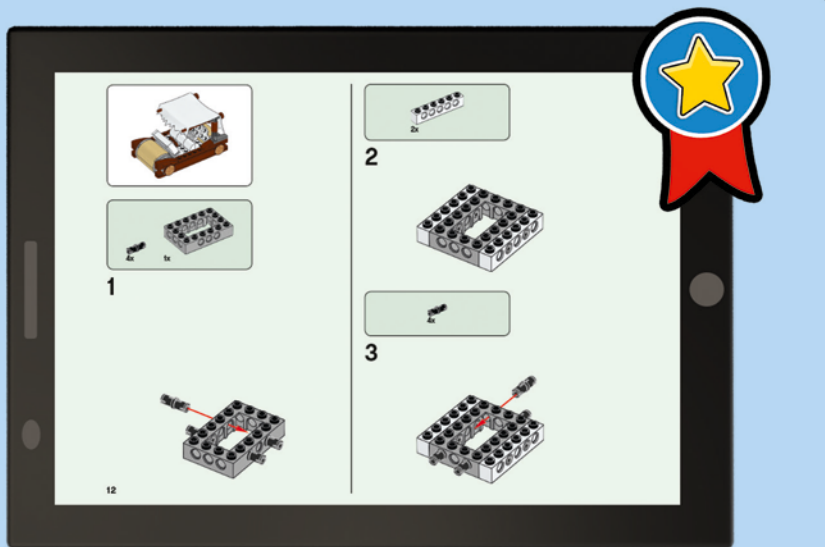

LEGO.com/apps

Check for compatibility
Vérifier la compatibilité
Comprueba tu compatibilidad

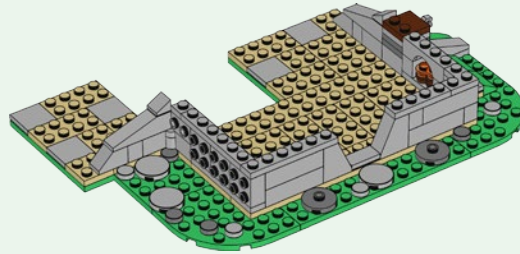
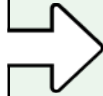
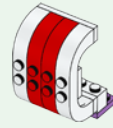
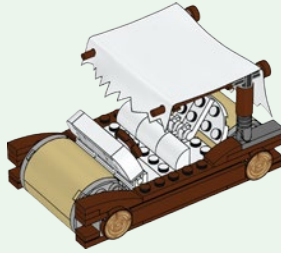
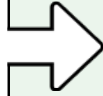

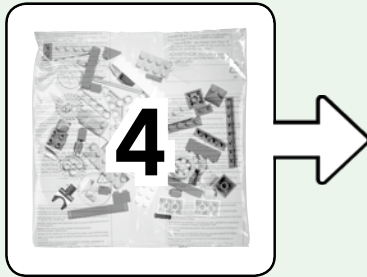
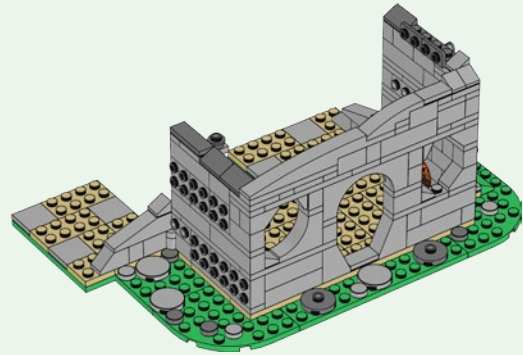
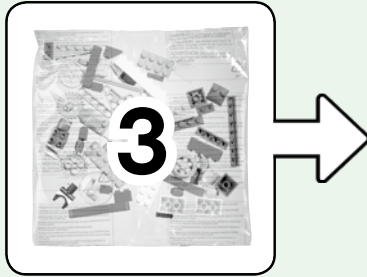

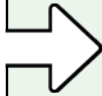
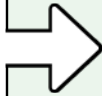

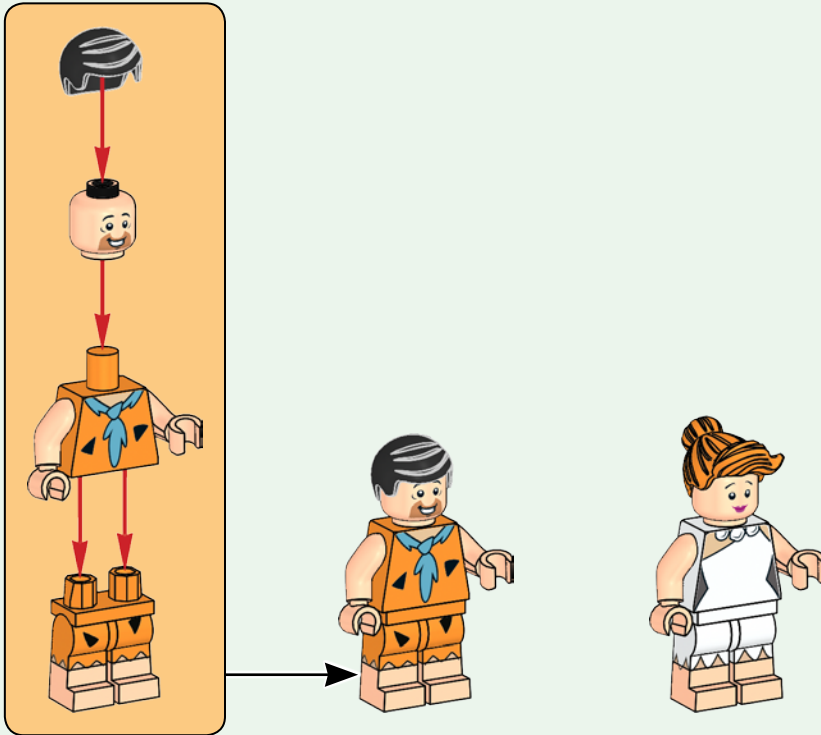
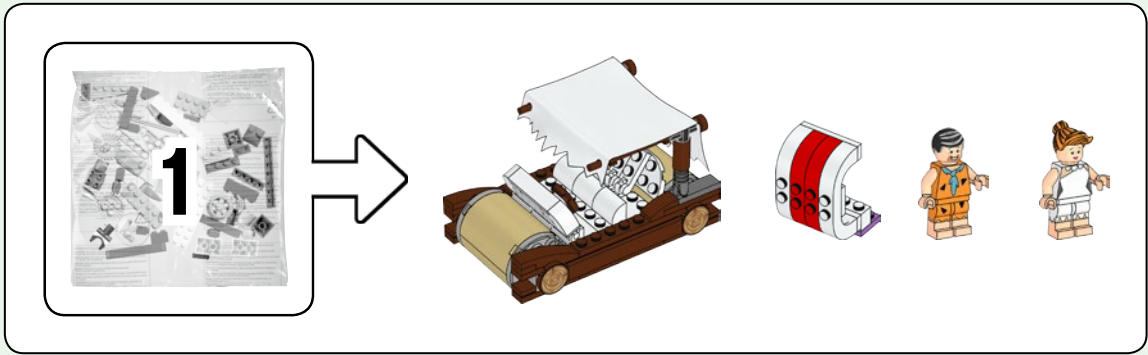

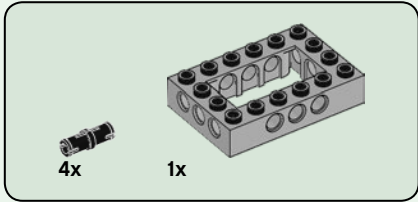
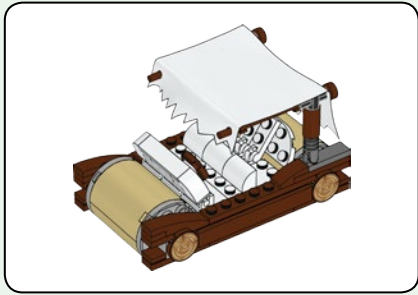

1

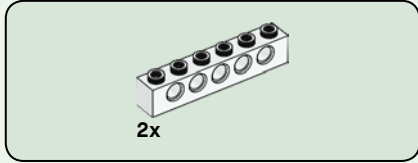
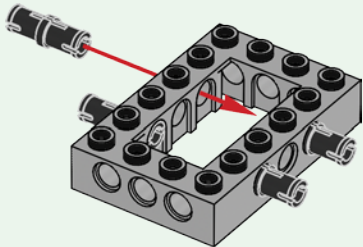

2

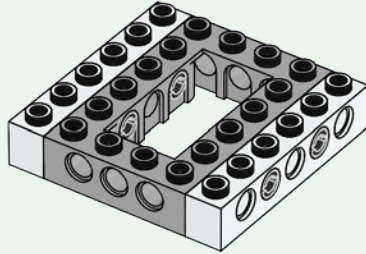

3

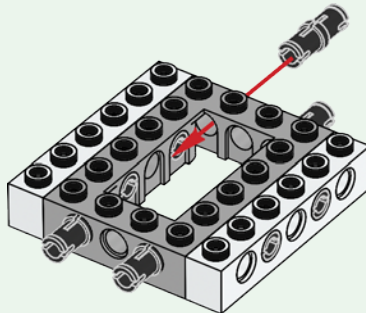

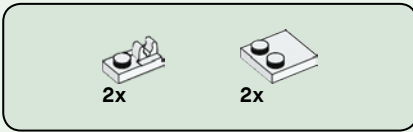

4

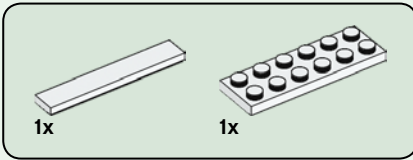
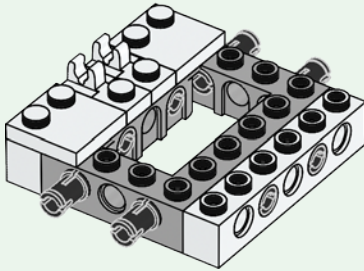

5

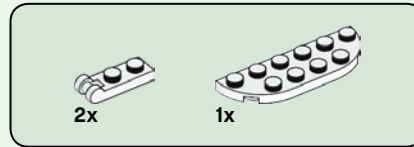
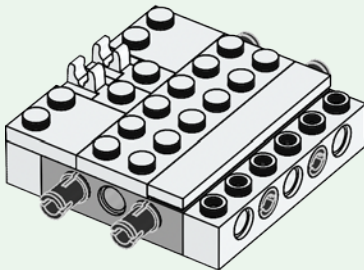

6

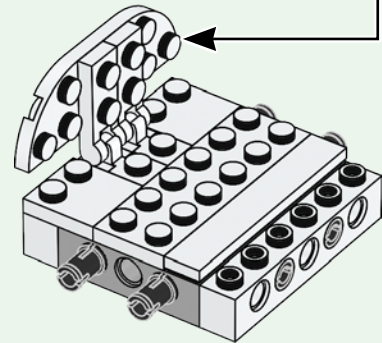
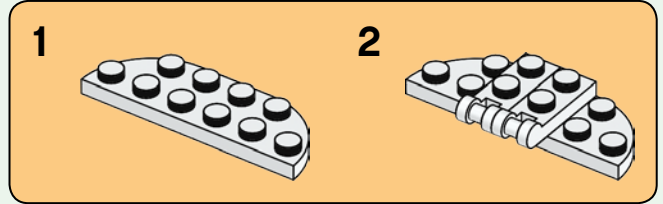



3x

7

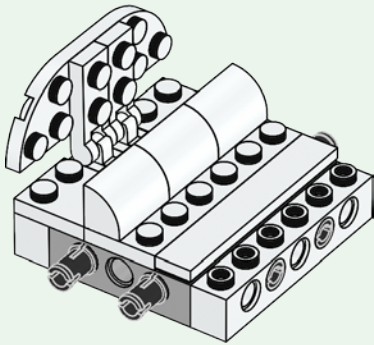

3x



3x

8

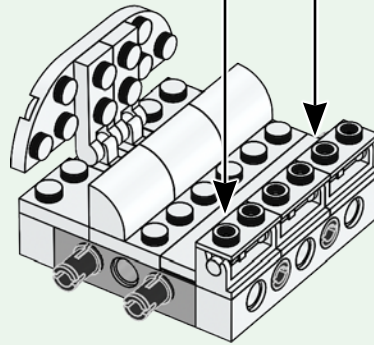
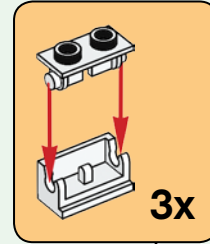

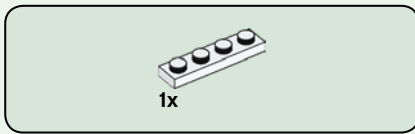

9

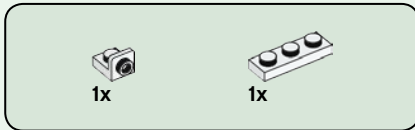
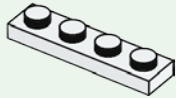

10

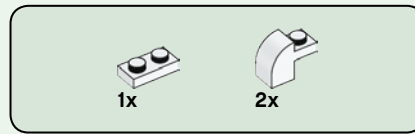
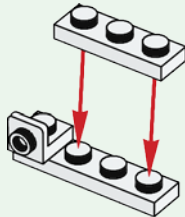

11

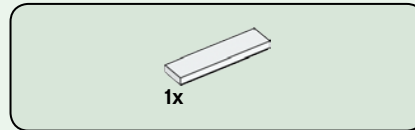
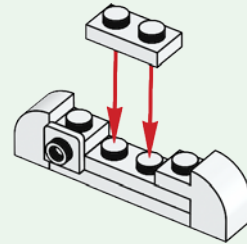

12

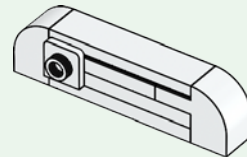



13

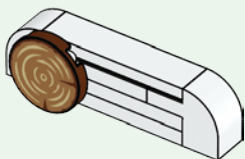

14

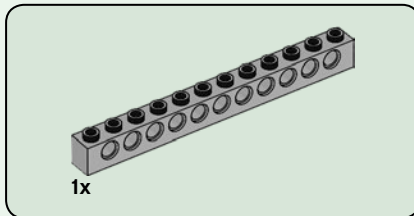
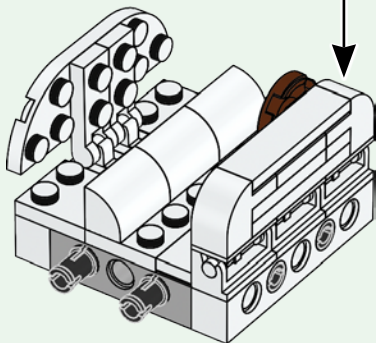

15

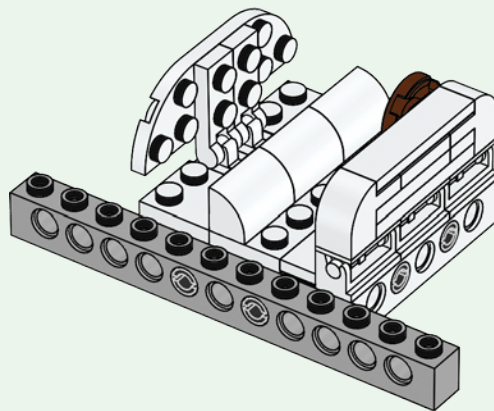



16

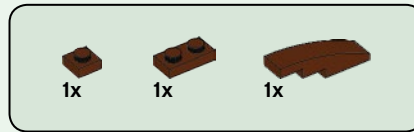
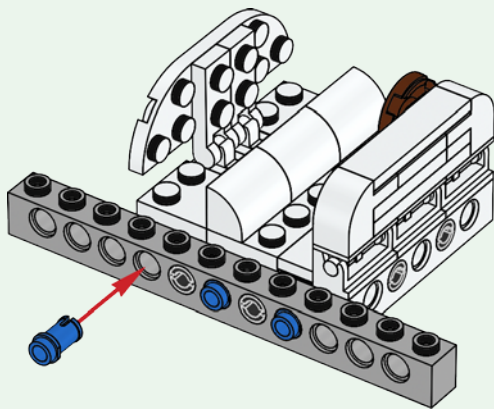

17

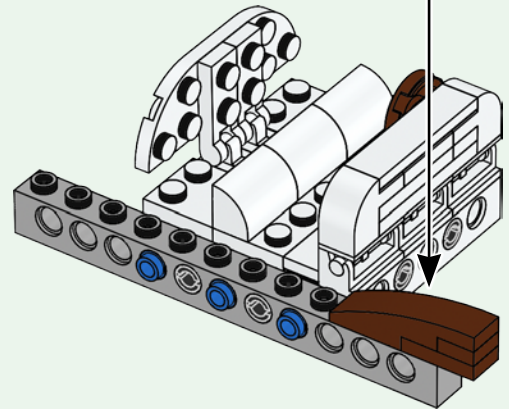
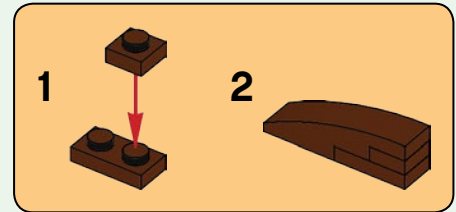

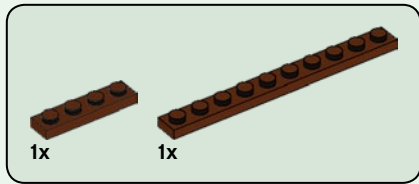

18

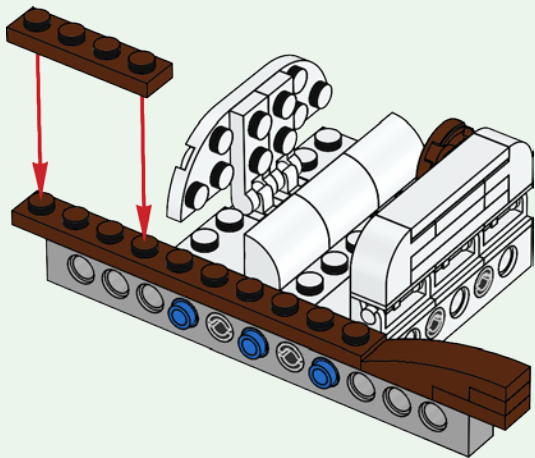

19

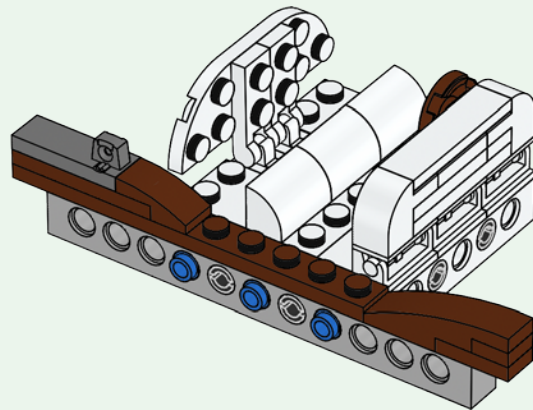

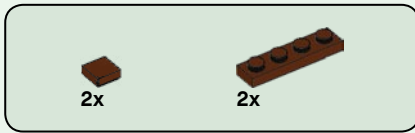

20

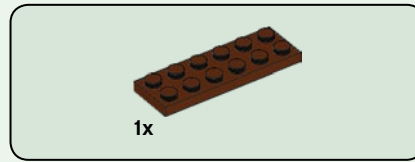
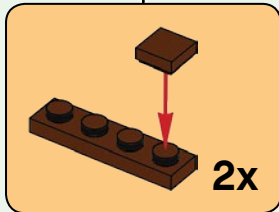
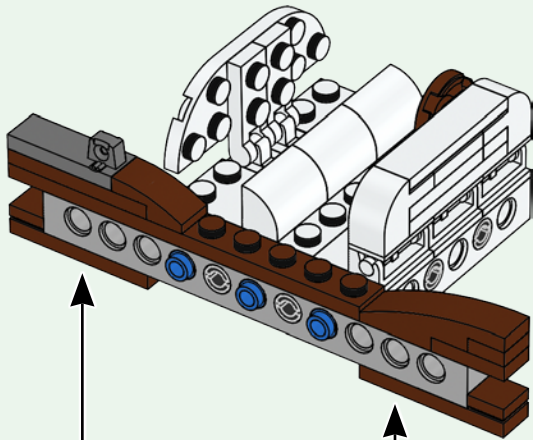

21

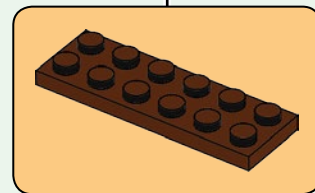
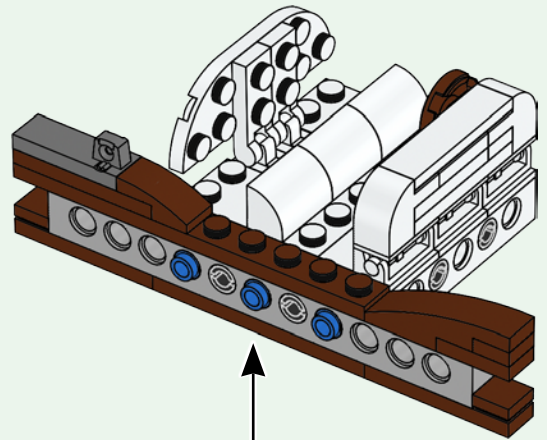

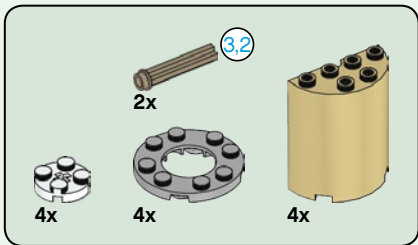
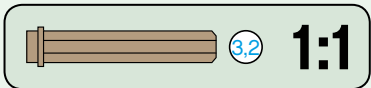

22

1



2

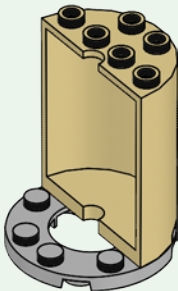

3



4



5

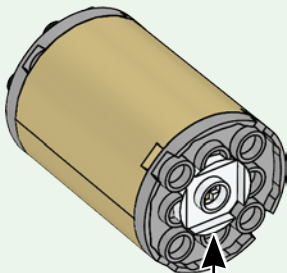

2x

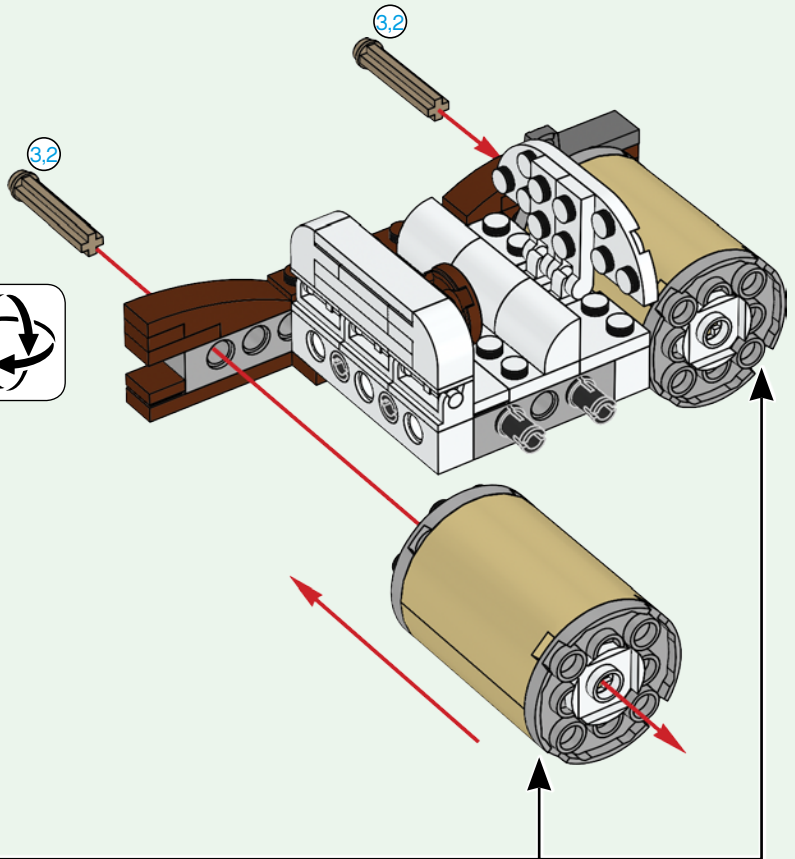
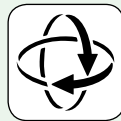

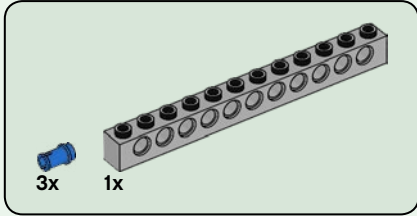
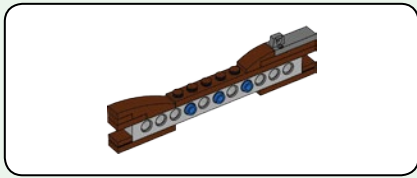

23

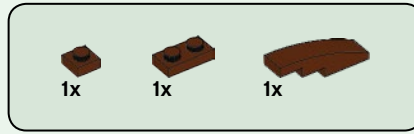
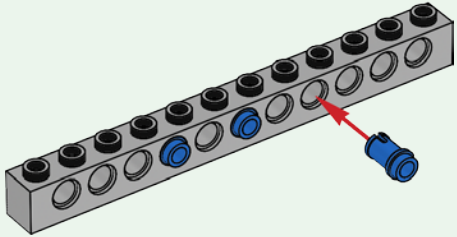

24

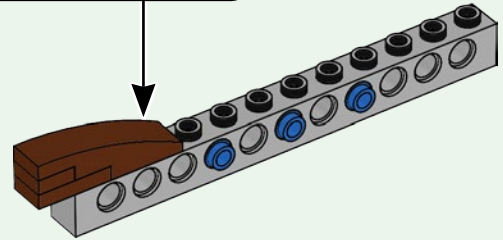
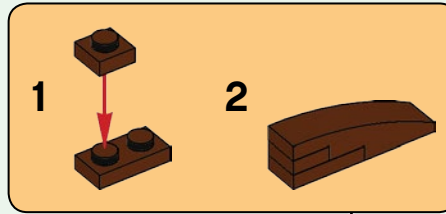

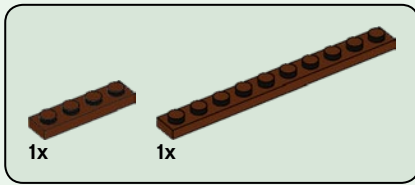

25

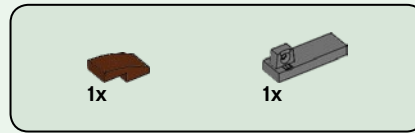
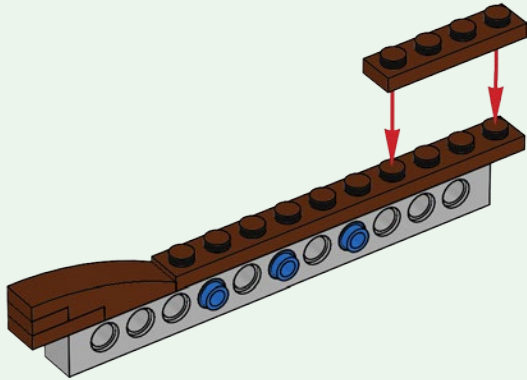

26

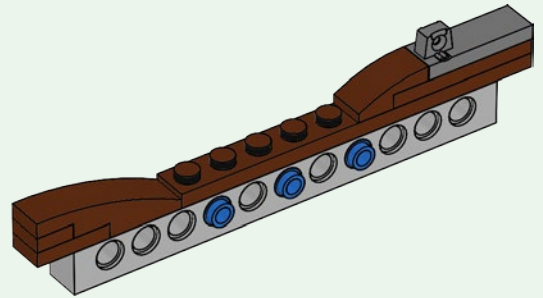

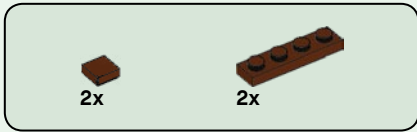

27

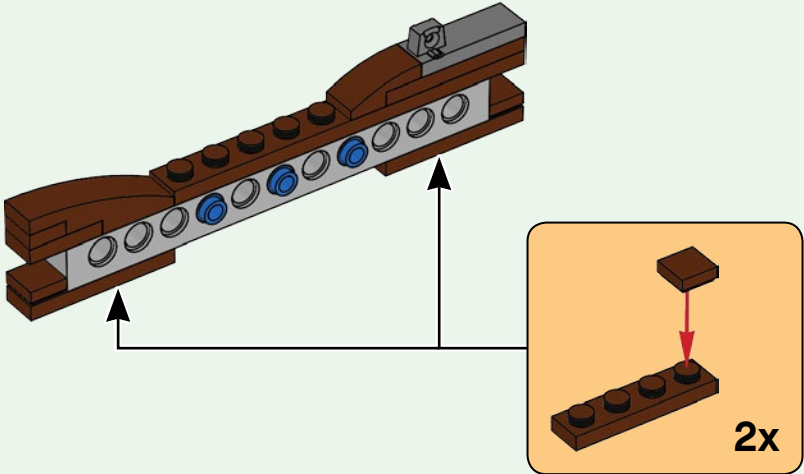

28

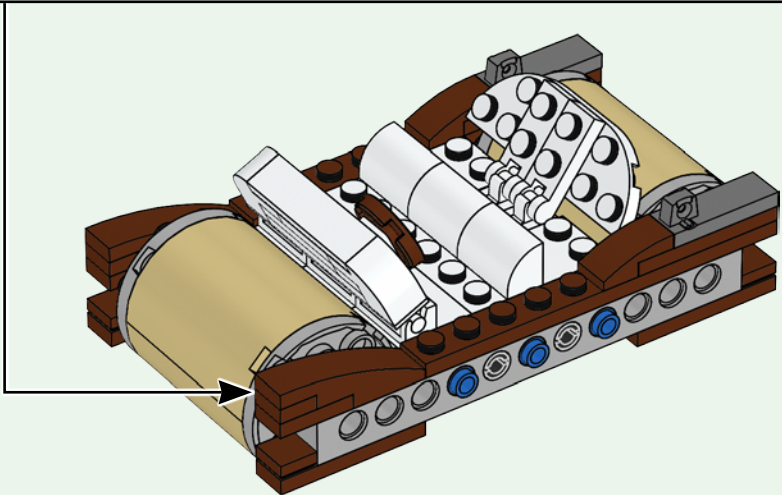

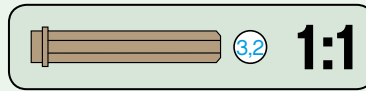
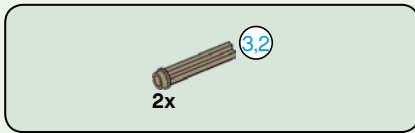

29

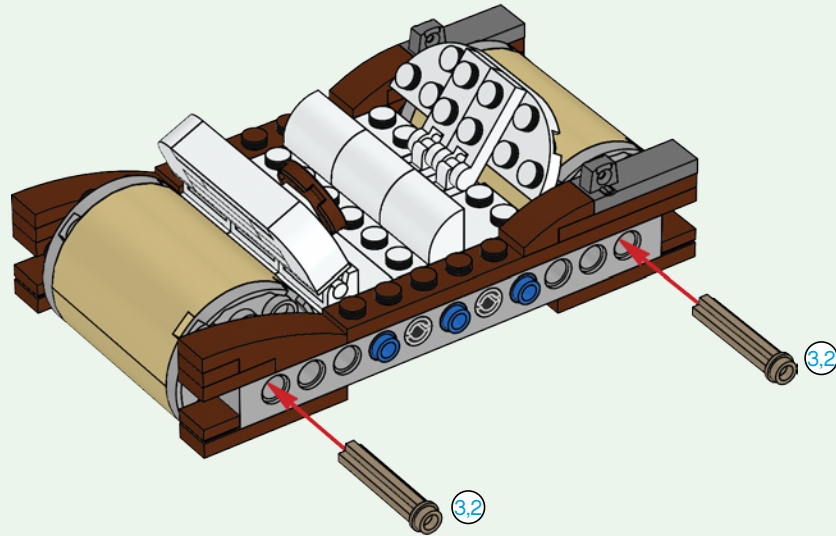

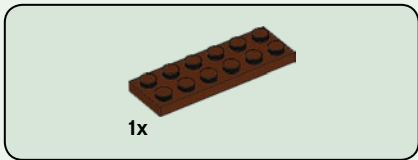

30

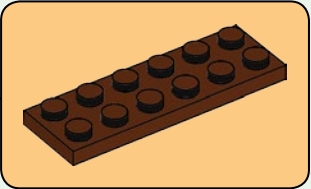
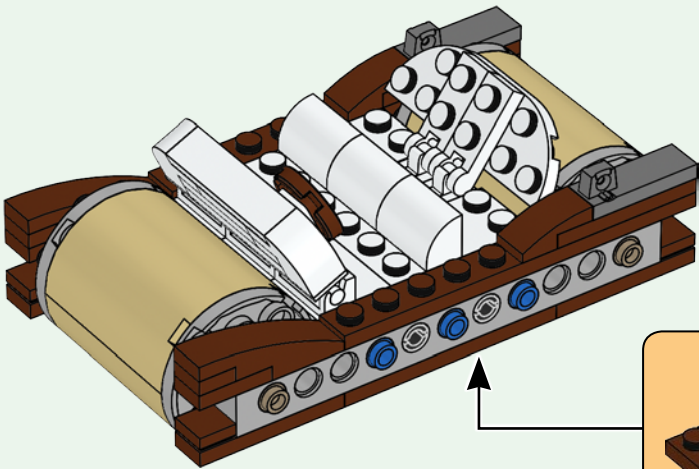



31

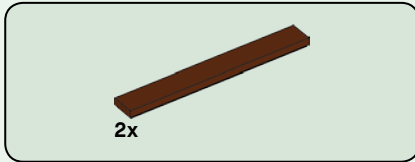
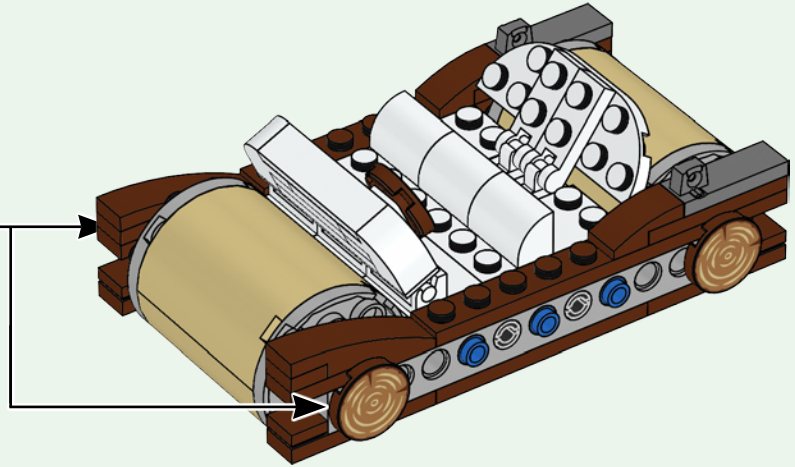

32

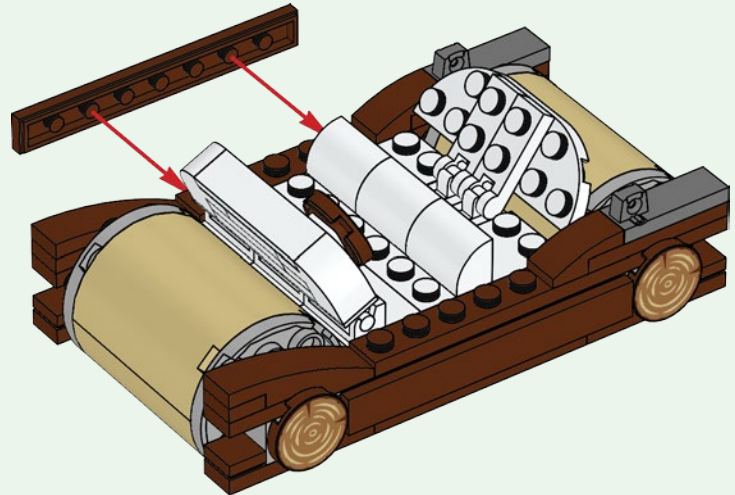

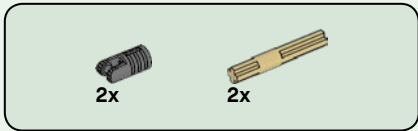

33

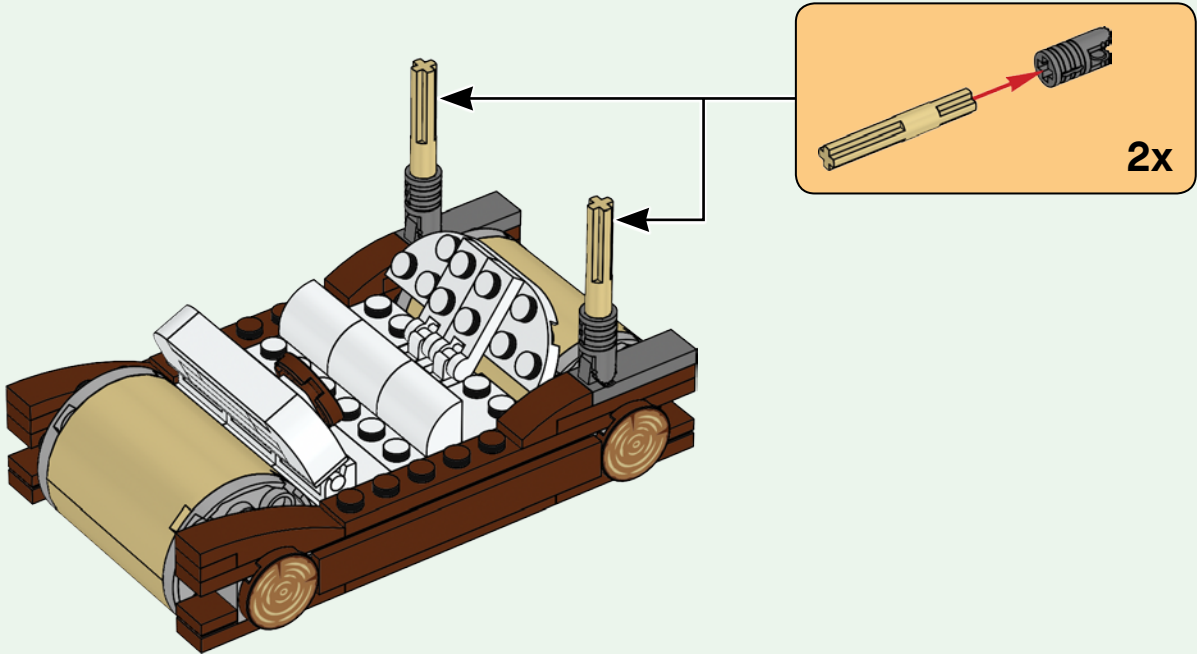

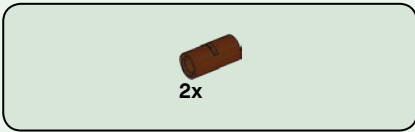

34

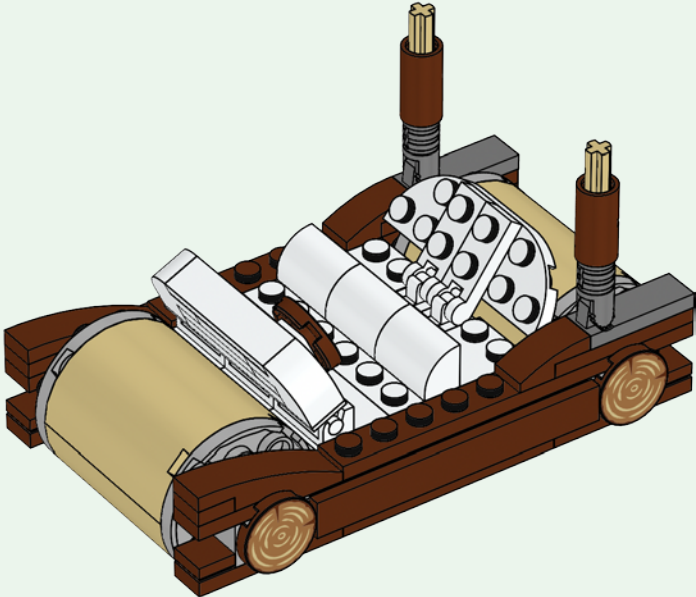

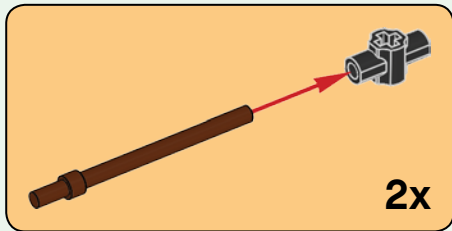
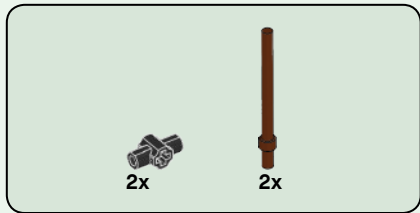

35

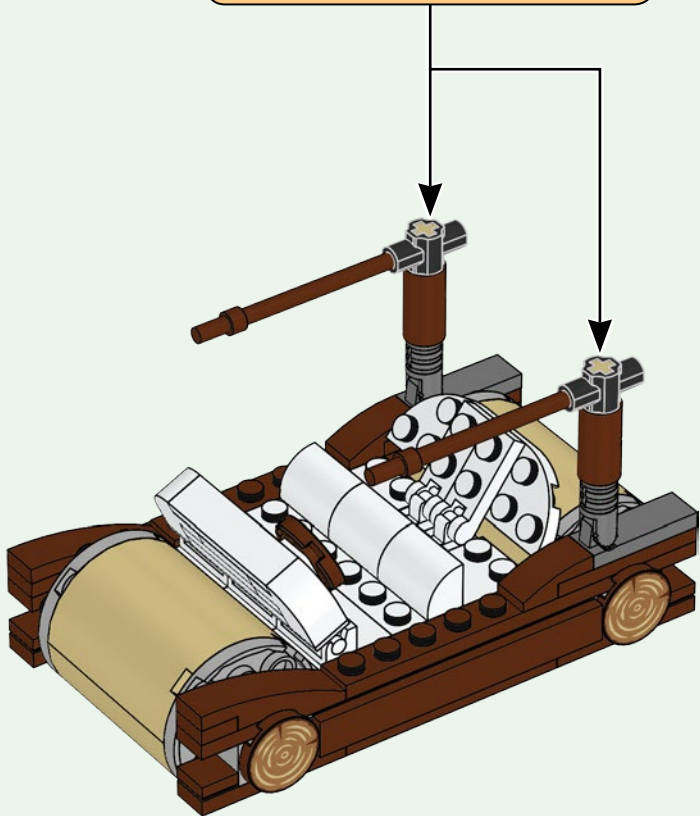

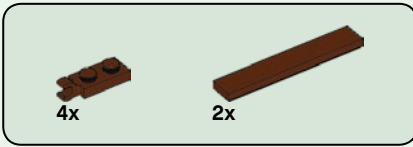

36

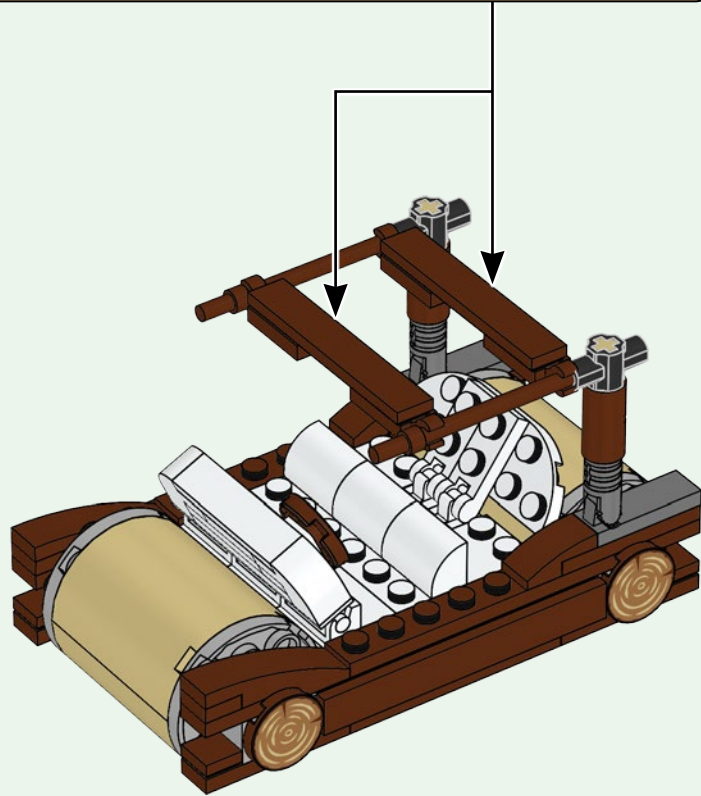
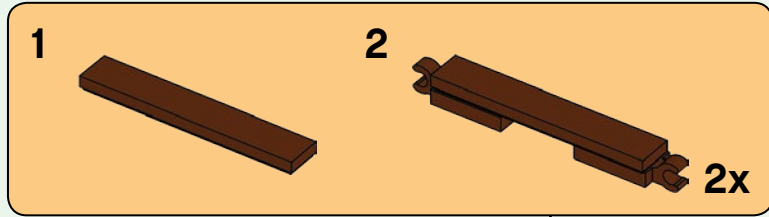

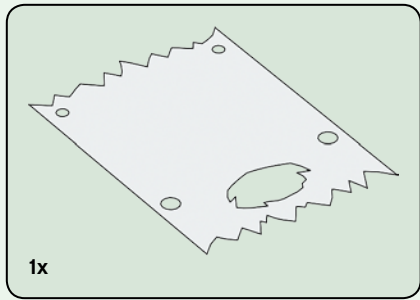

37

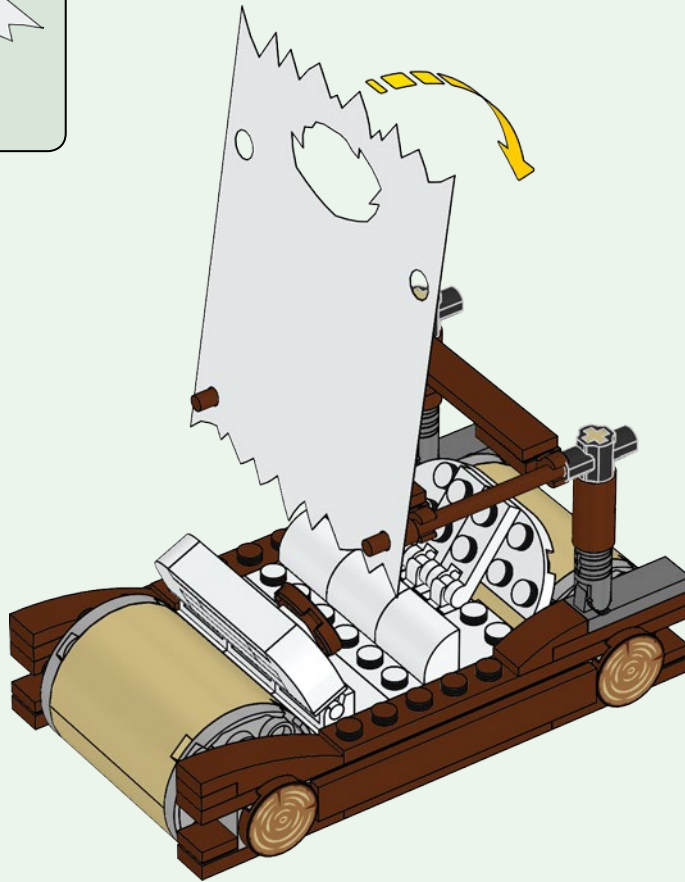

2x

38

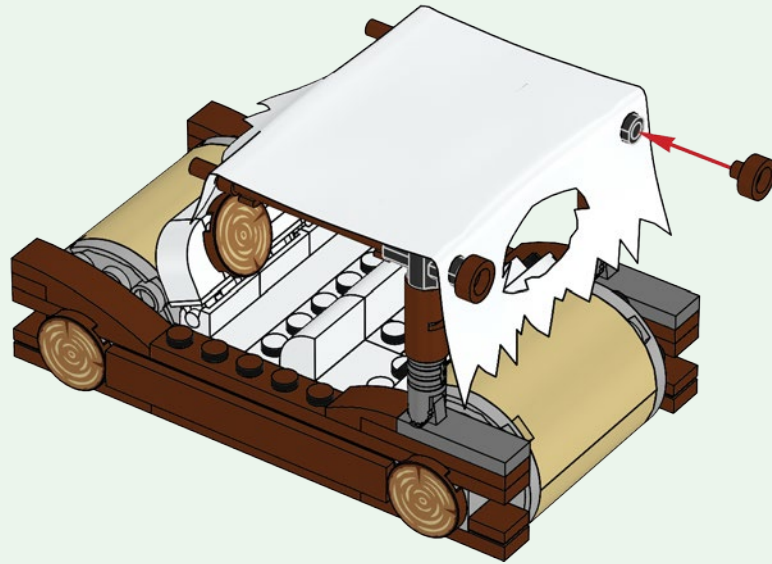

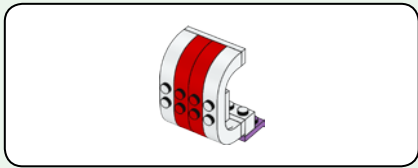

39

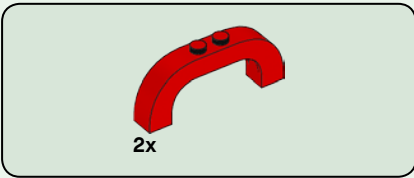

40

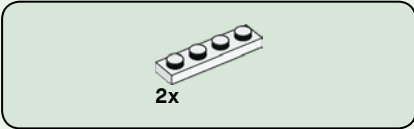
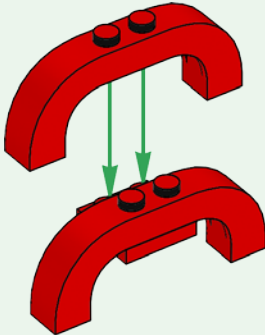

41

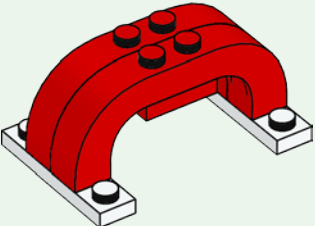

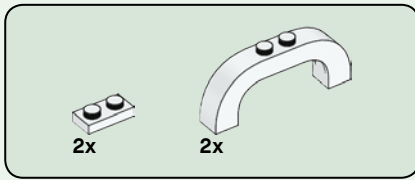

42

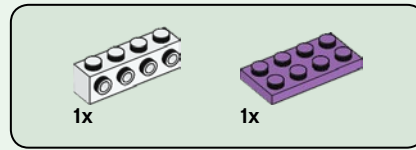
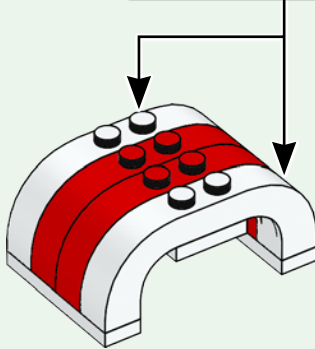
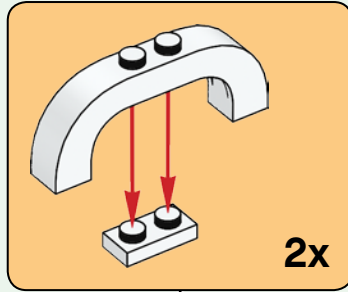

43

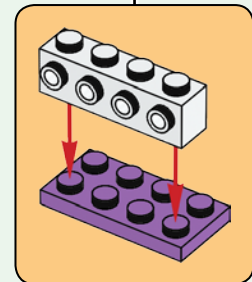
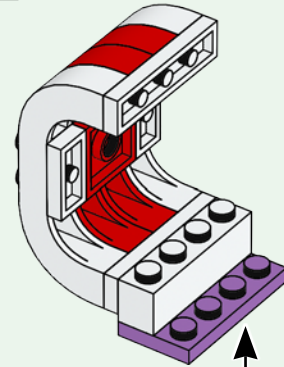
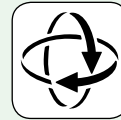

44

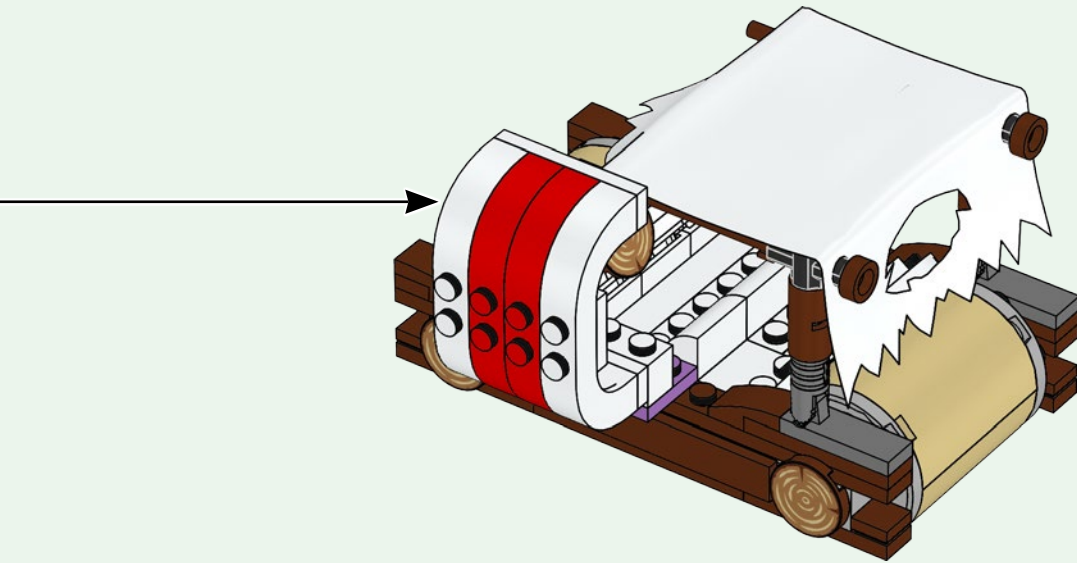

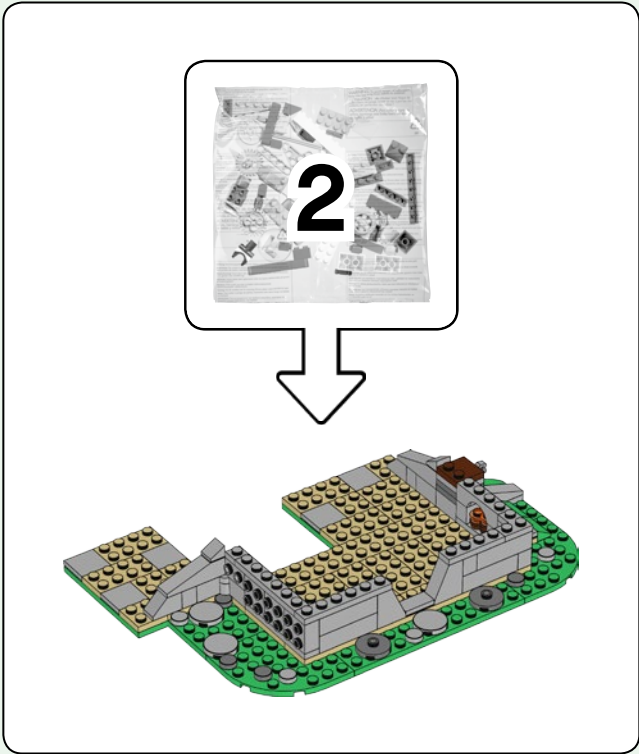
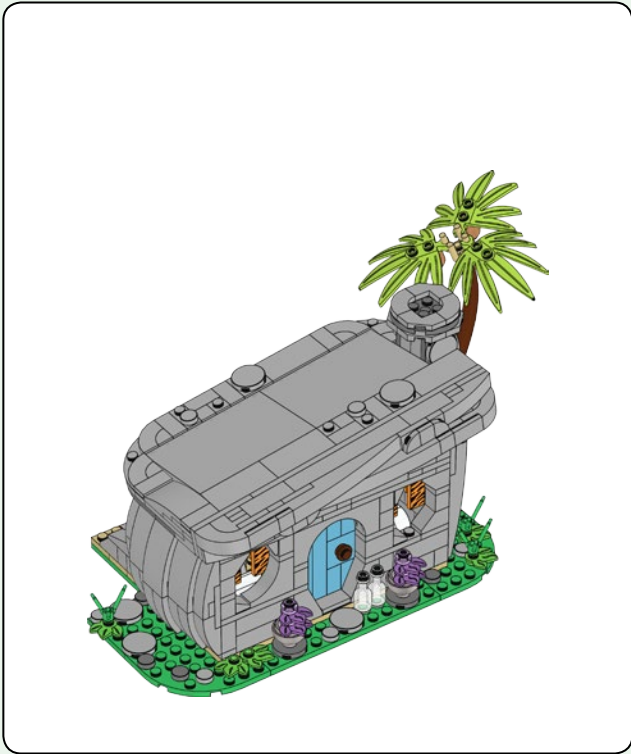

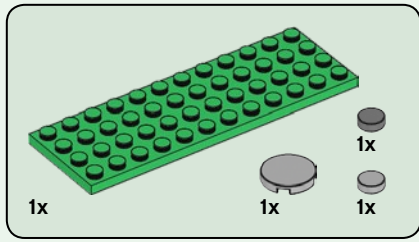

1

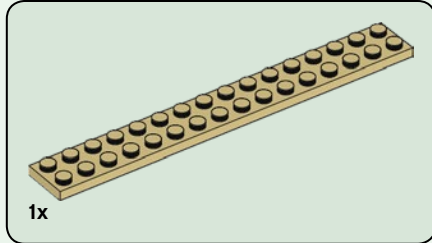
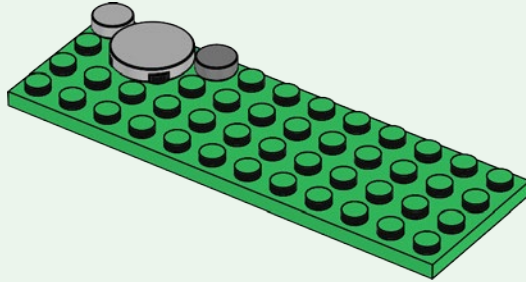

2

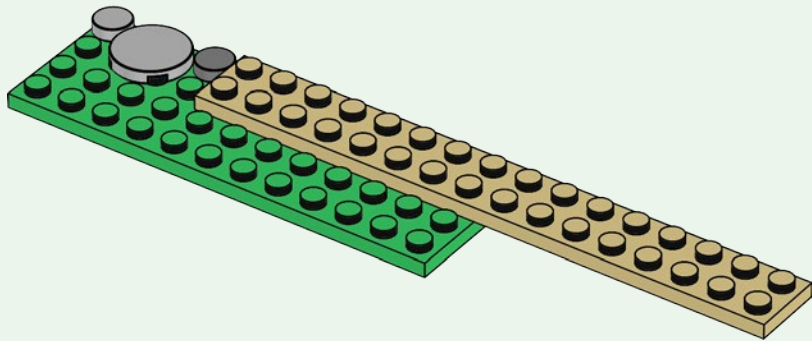

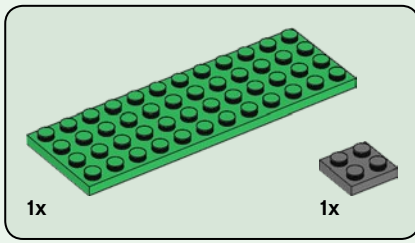

3

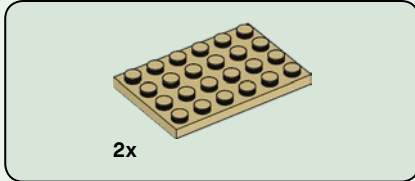
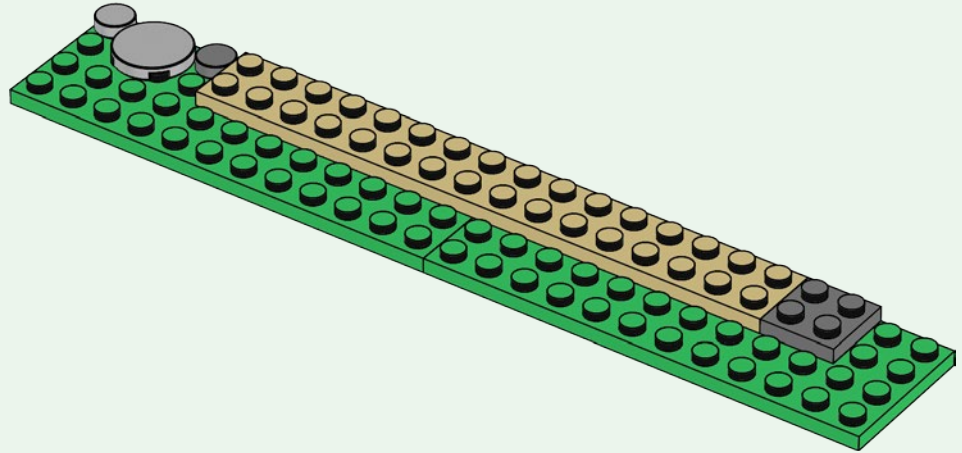

4

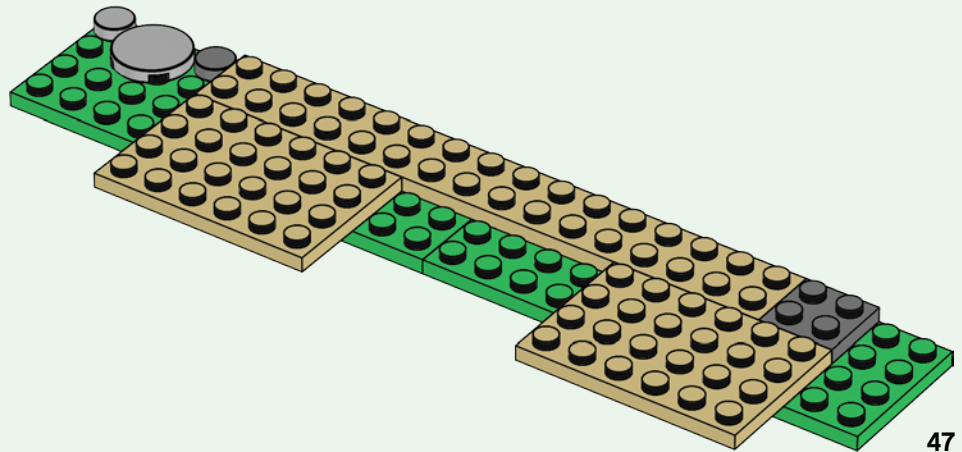

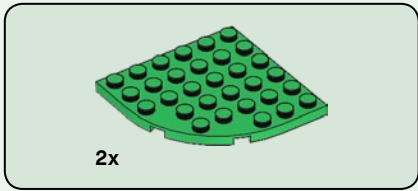

5

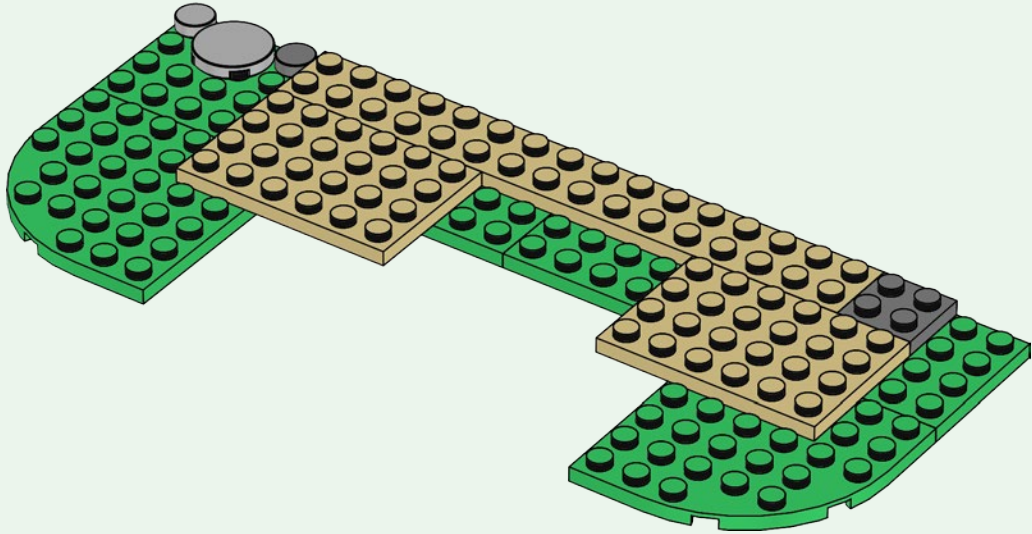

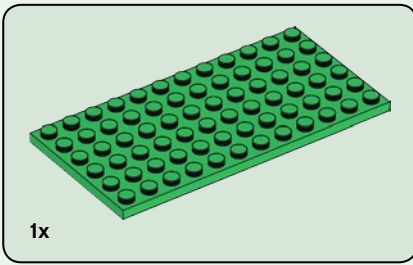

6

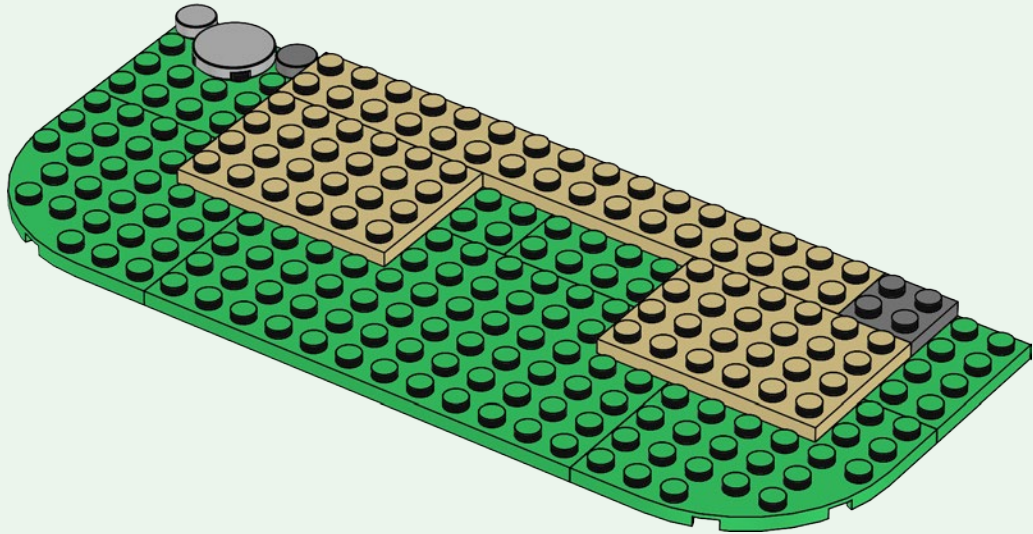



3x

7

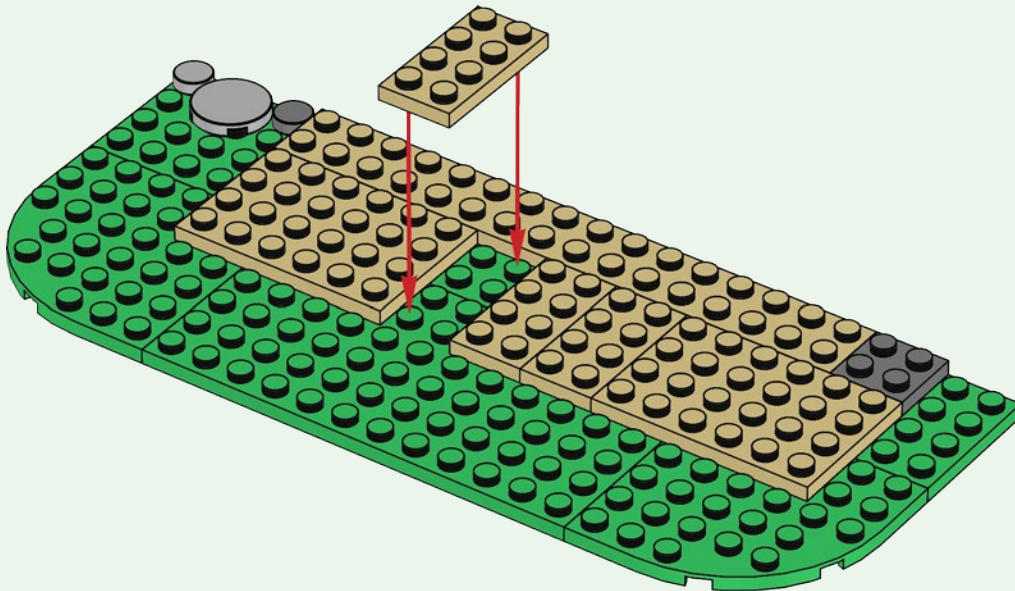

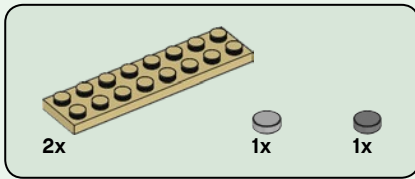

8

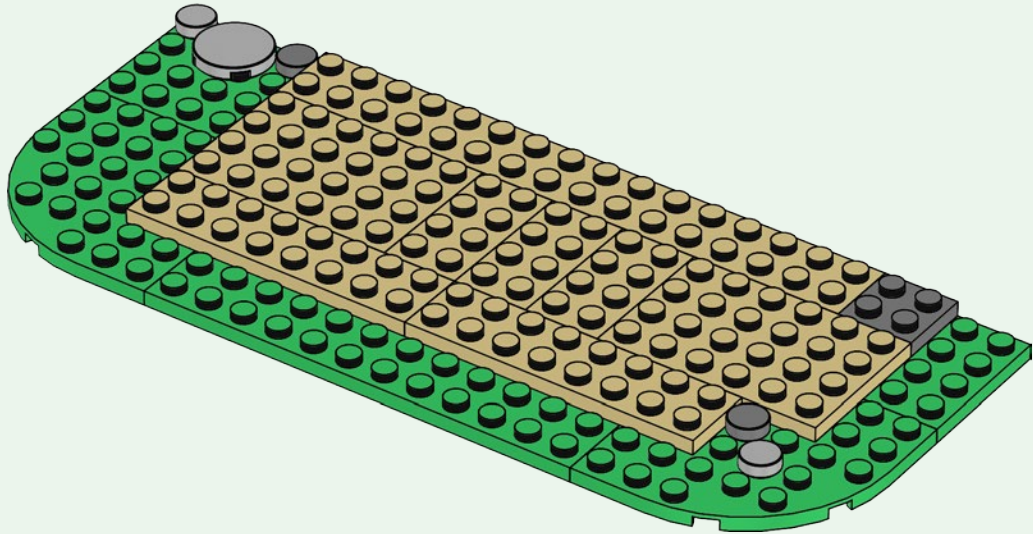

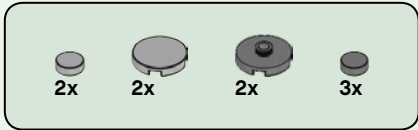

9

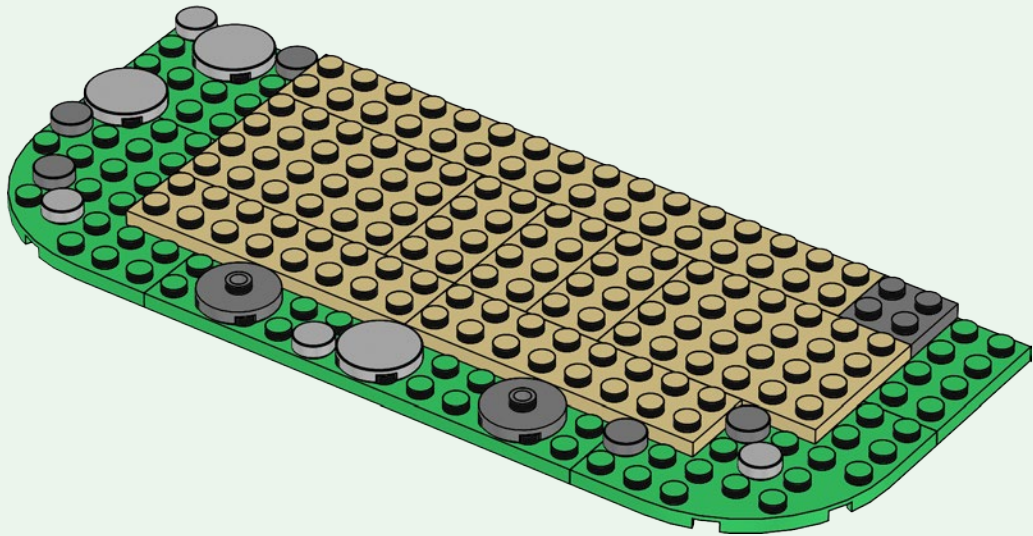

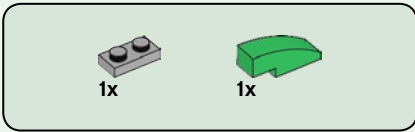

10

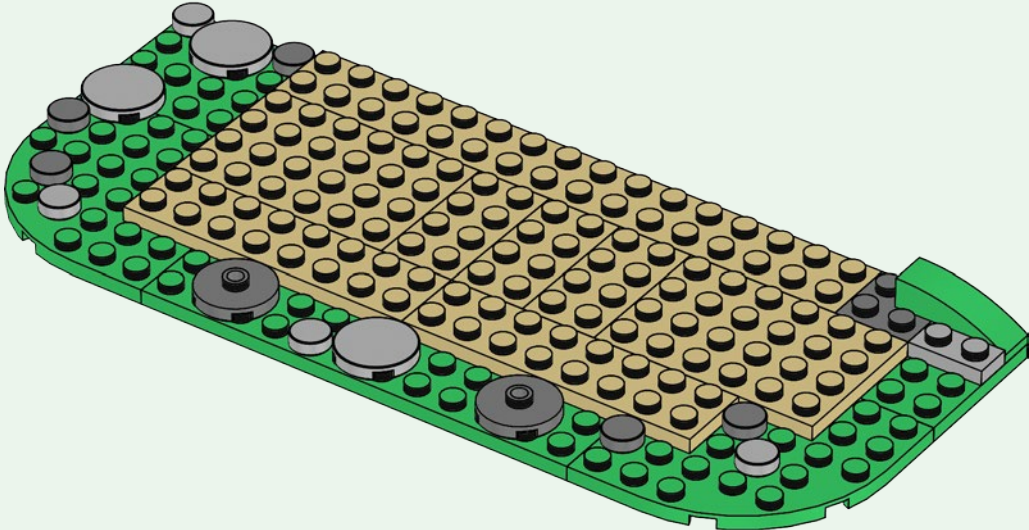

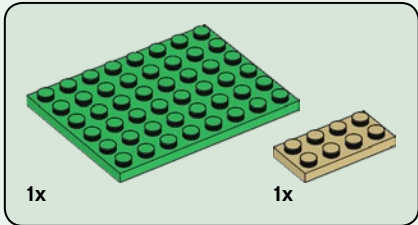
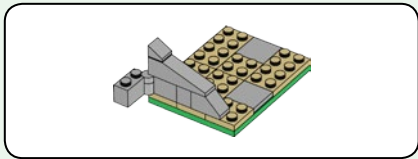

11

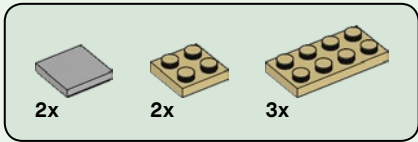
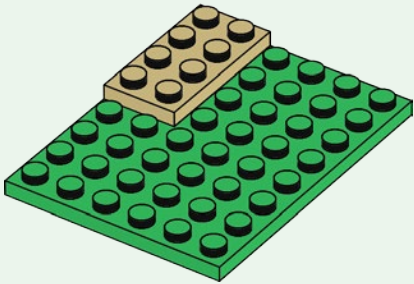

12

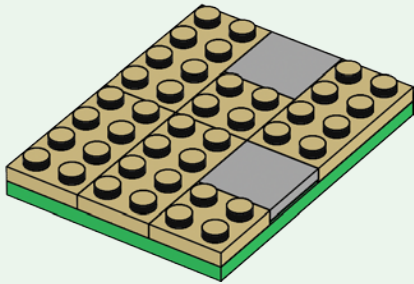

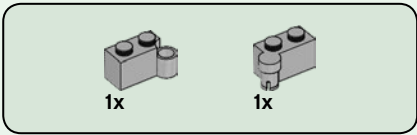

13

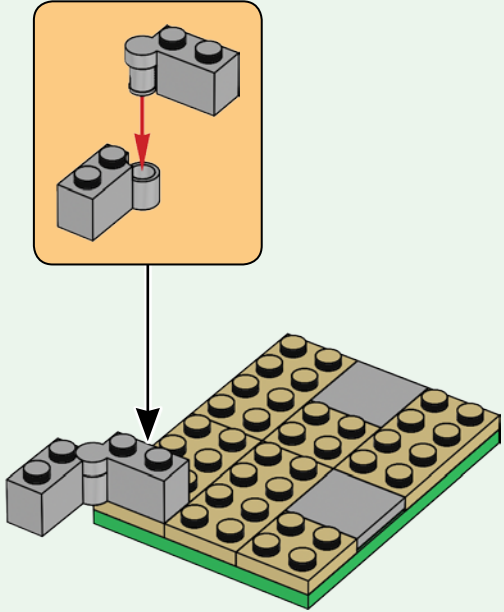

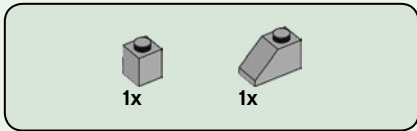

14

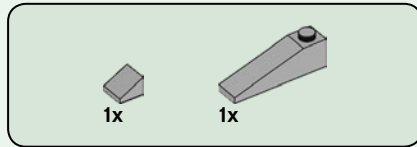
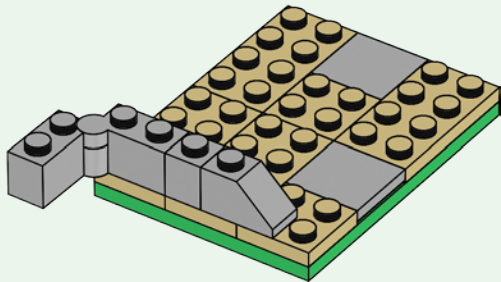

15

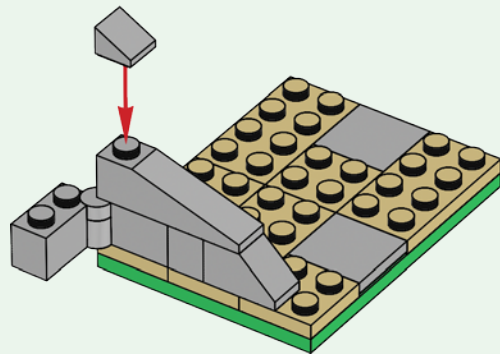

16

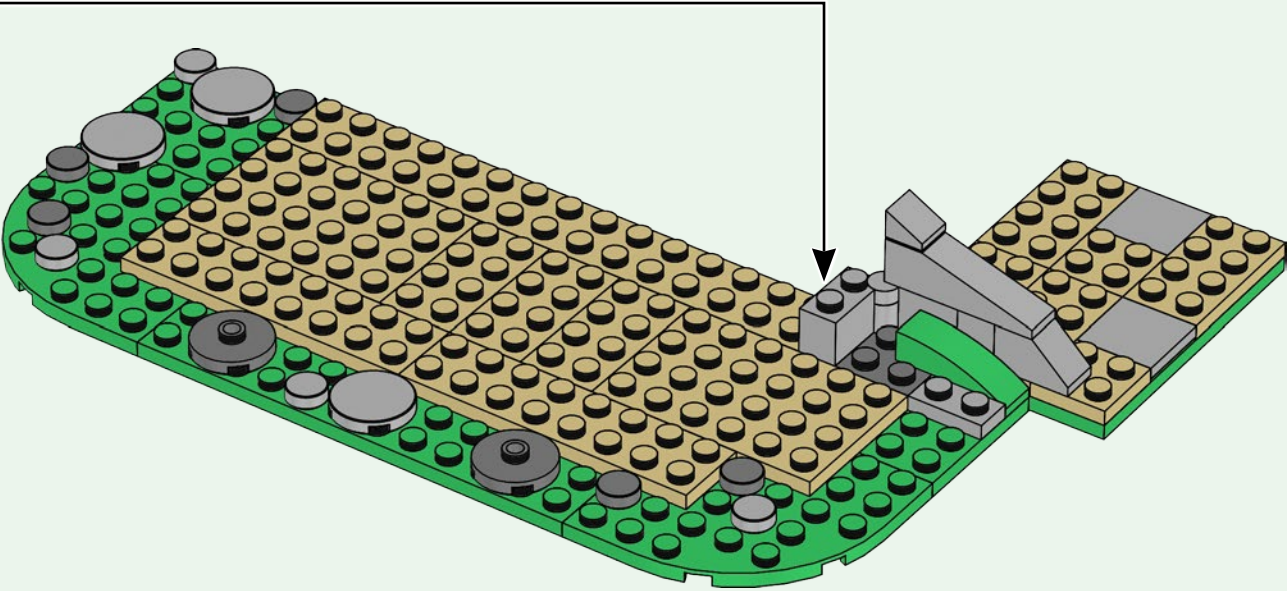

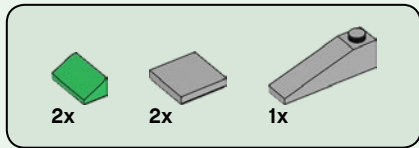

17

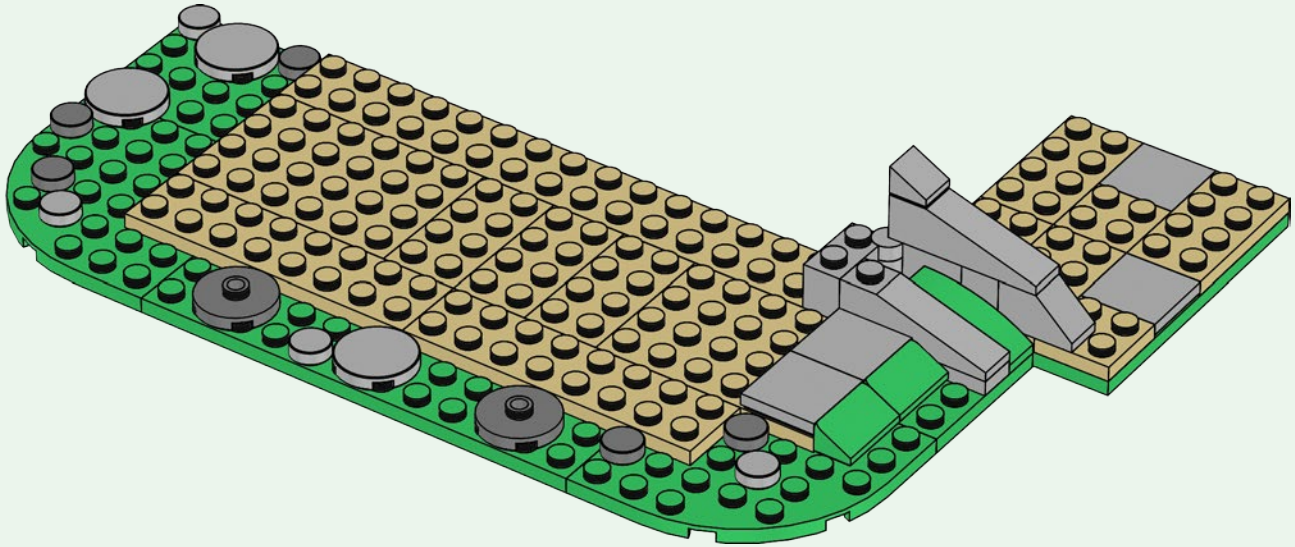

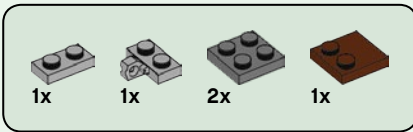

18

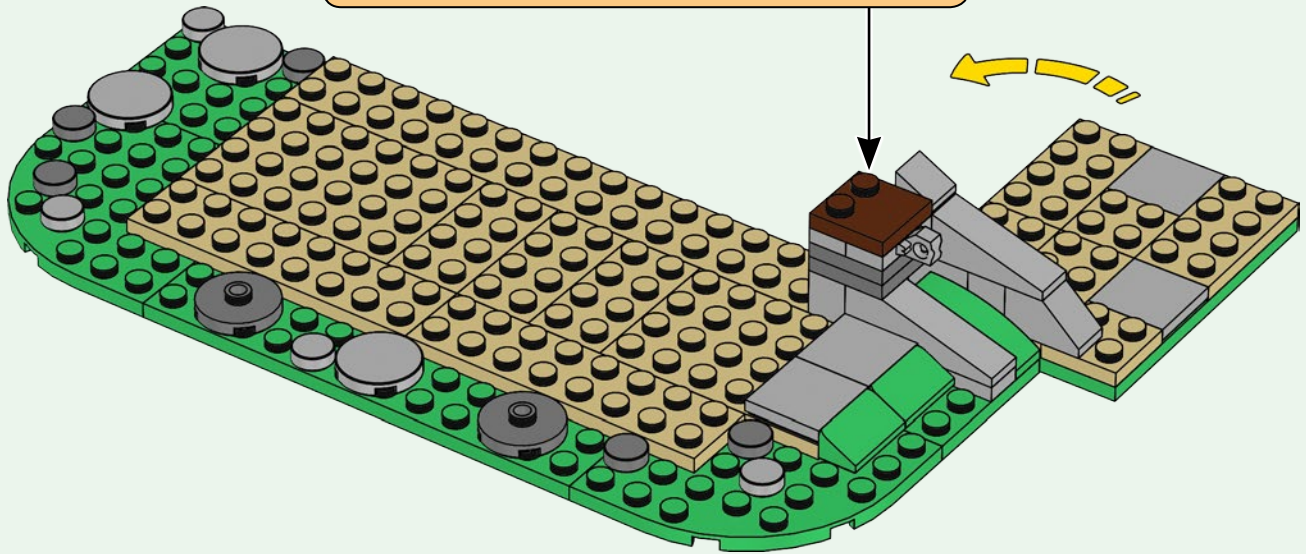
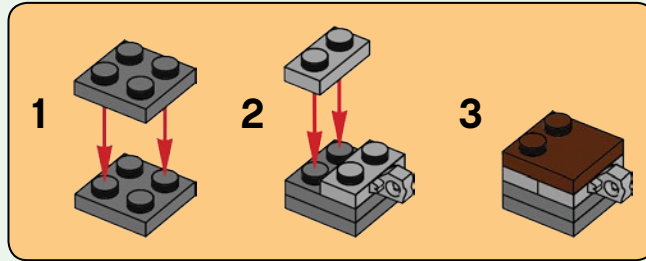

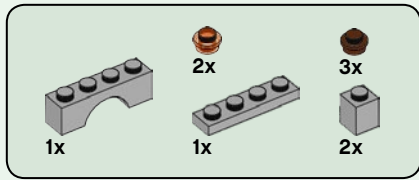

19

1

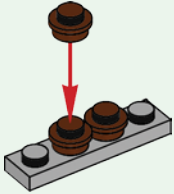

2

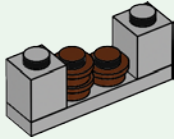

3

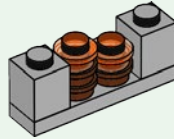

4

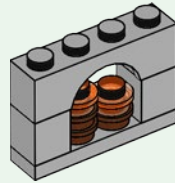

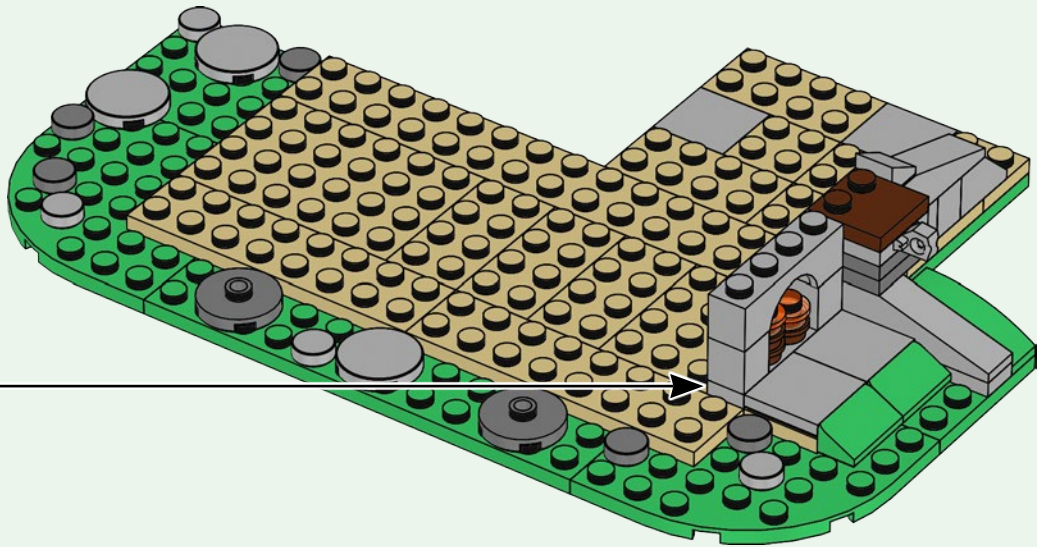

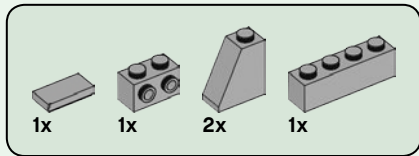

20

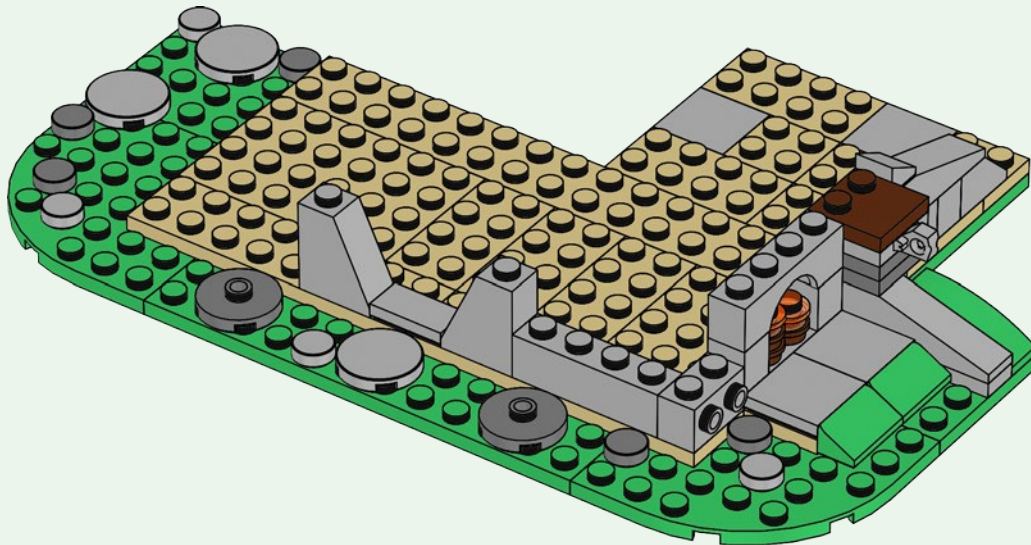

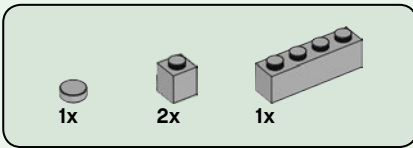

21

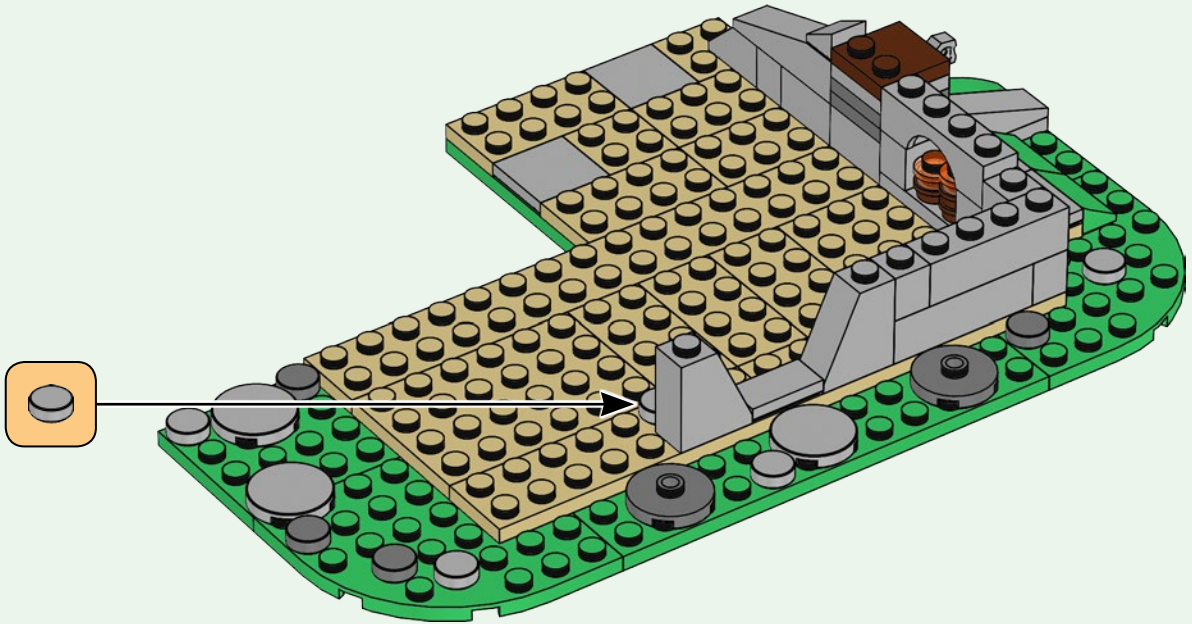

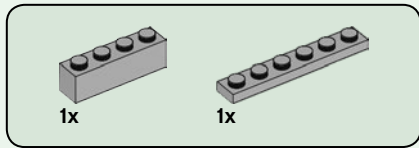

22

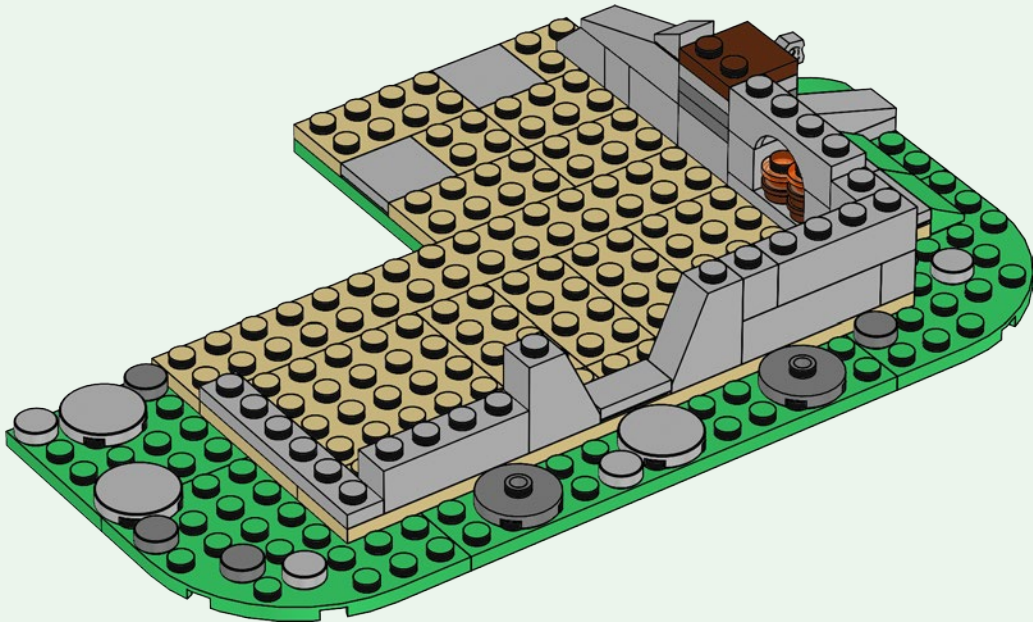

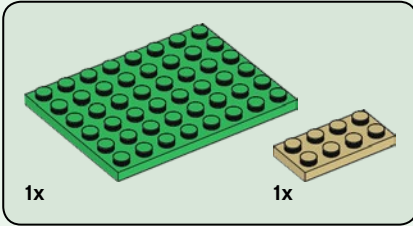
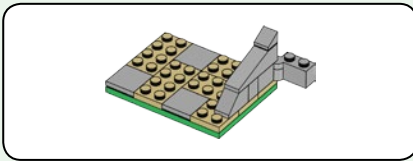

23

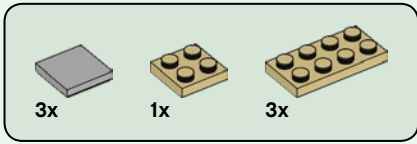
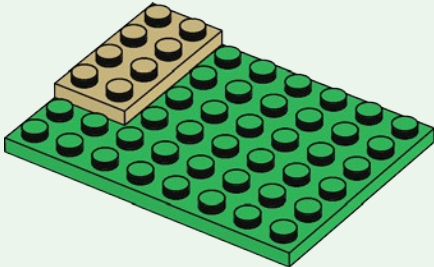

24

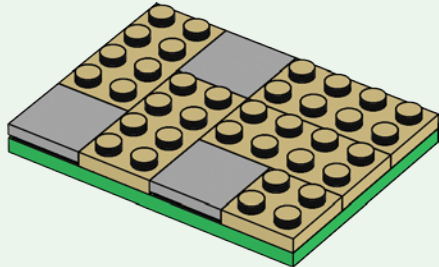



1x



1x

25

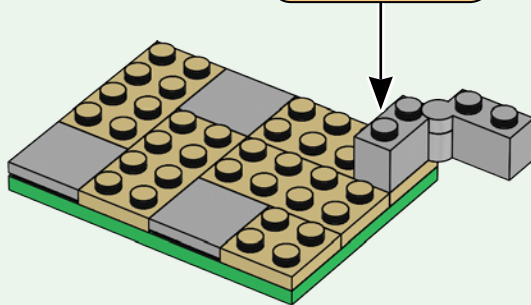
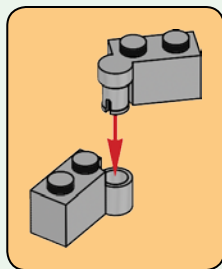

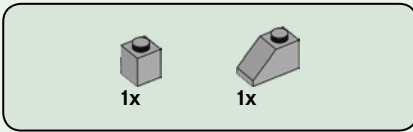

26

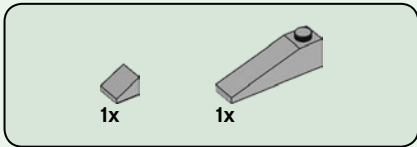
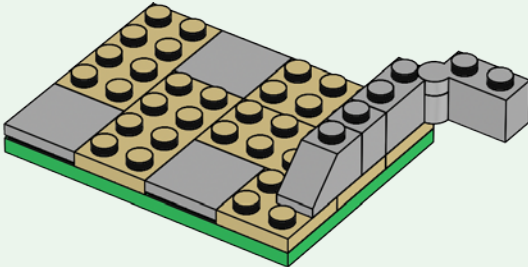

27

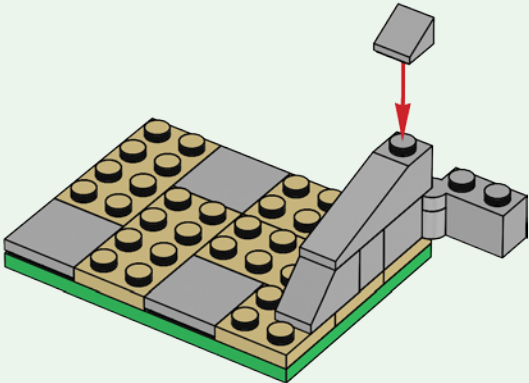

28

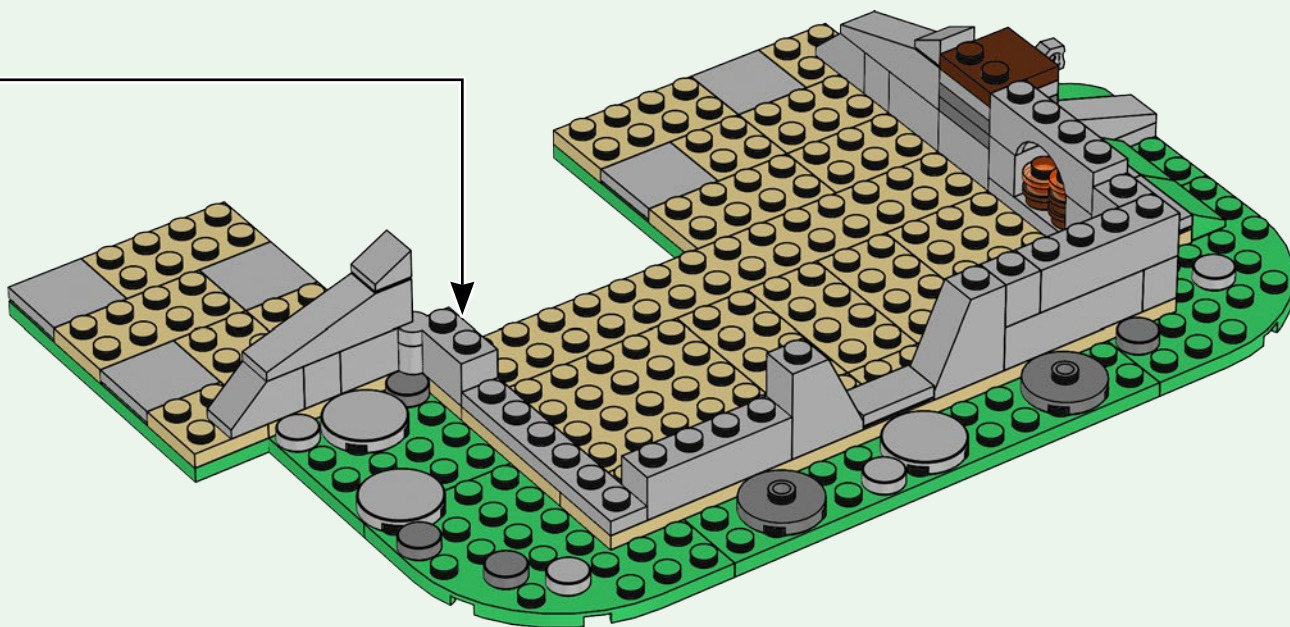

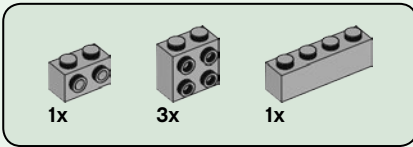

29

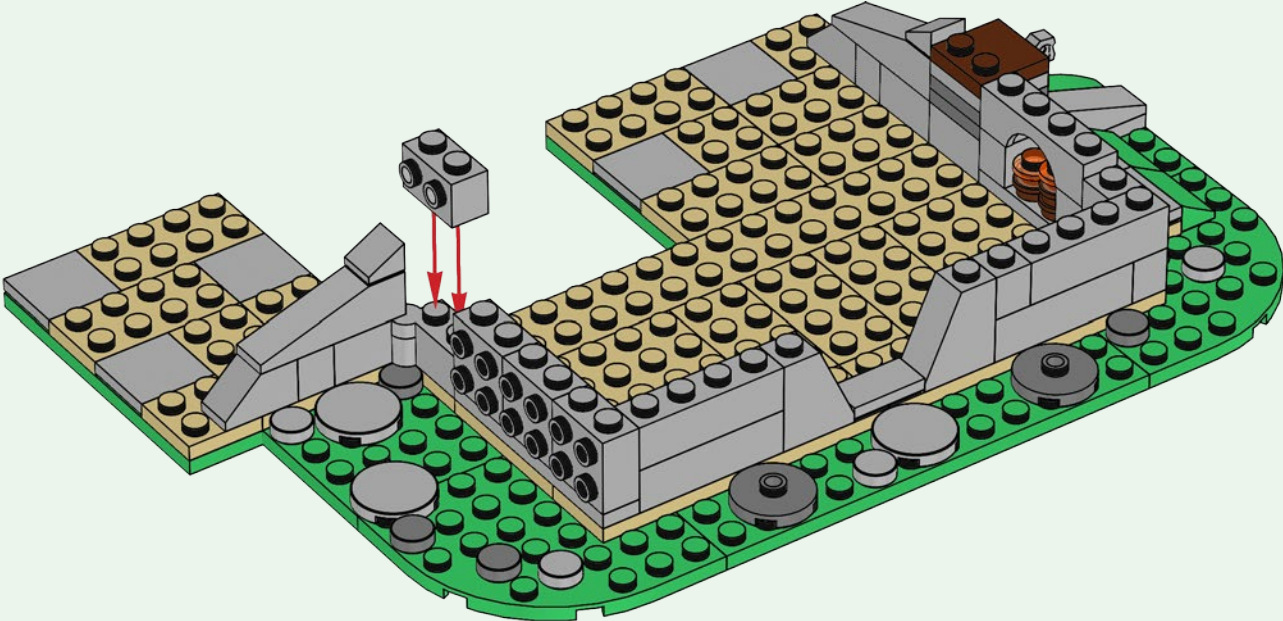

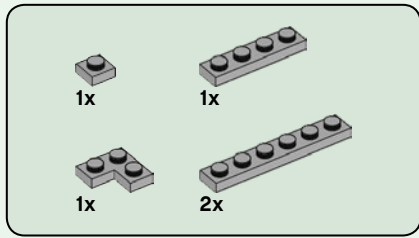

30

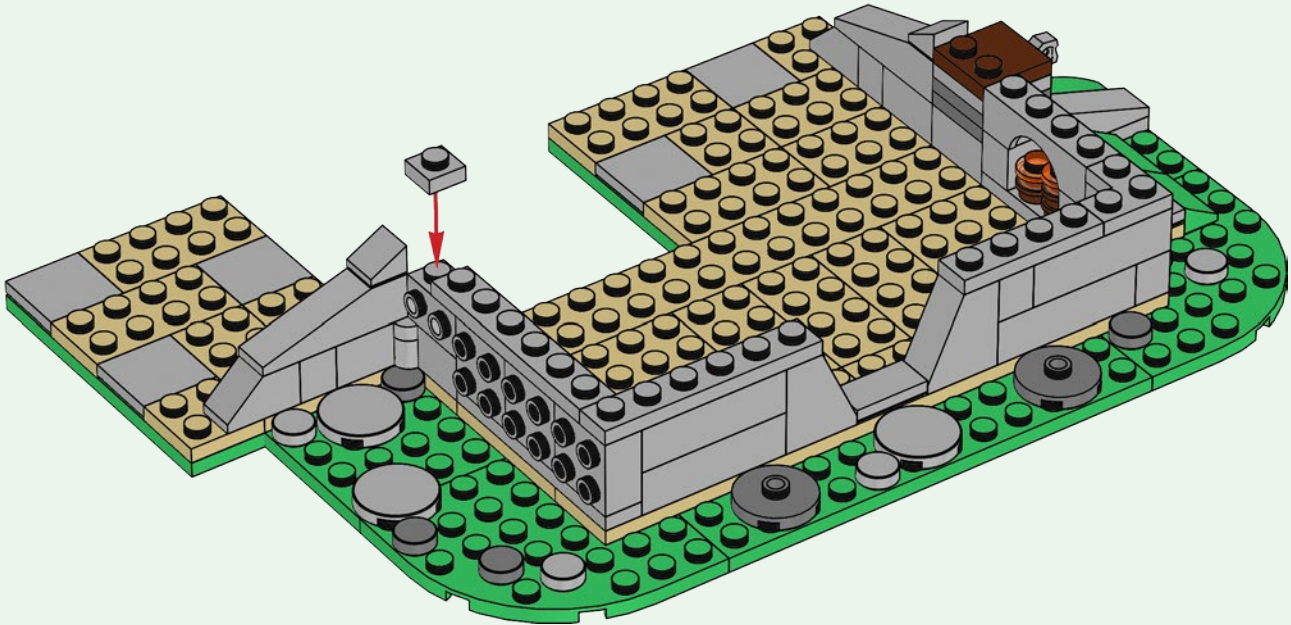

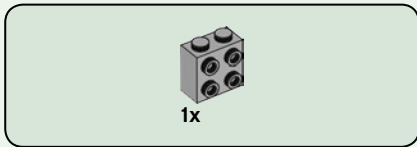
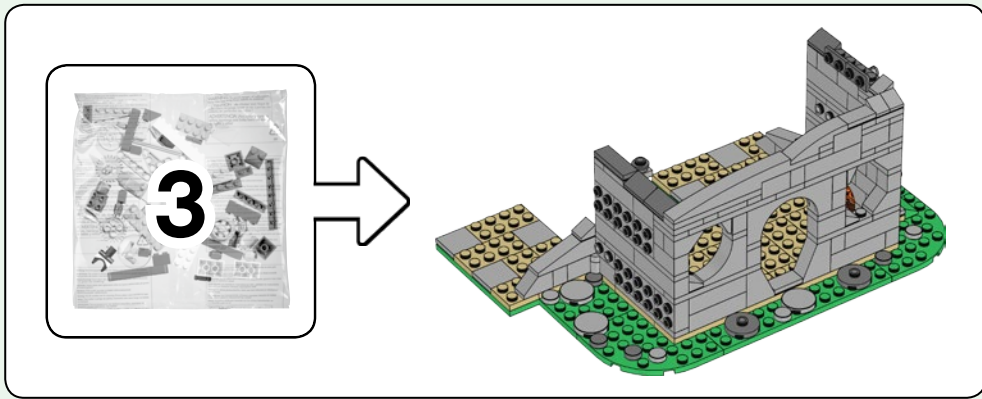

31

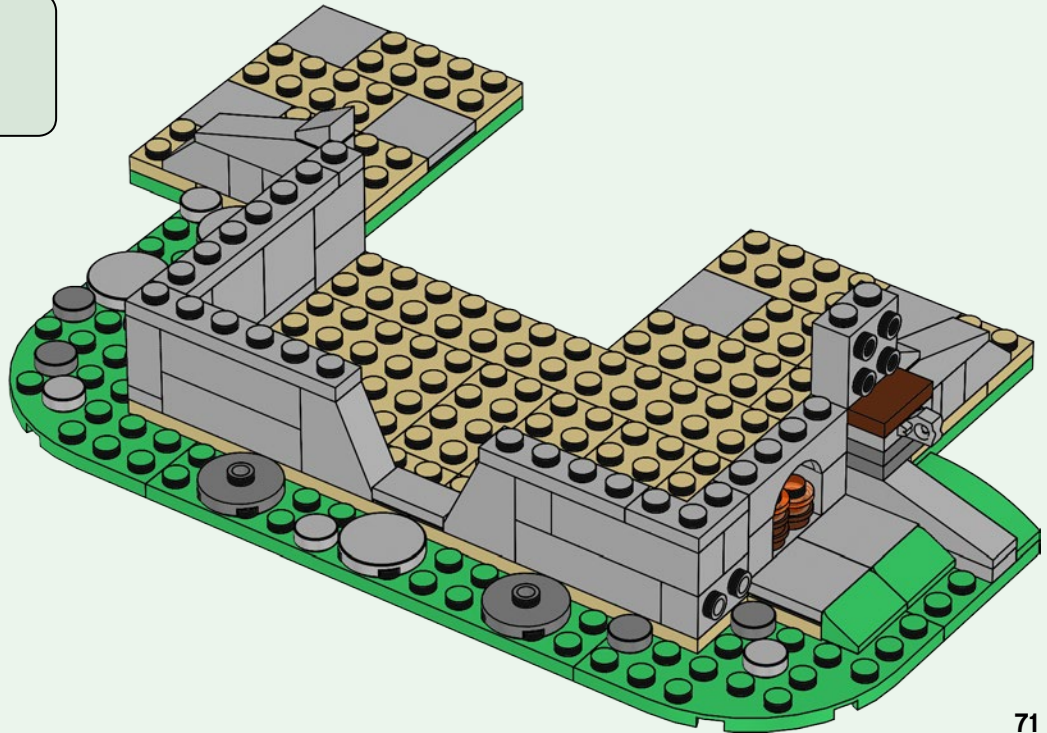

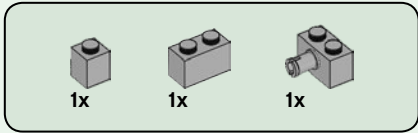

32

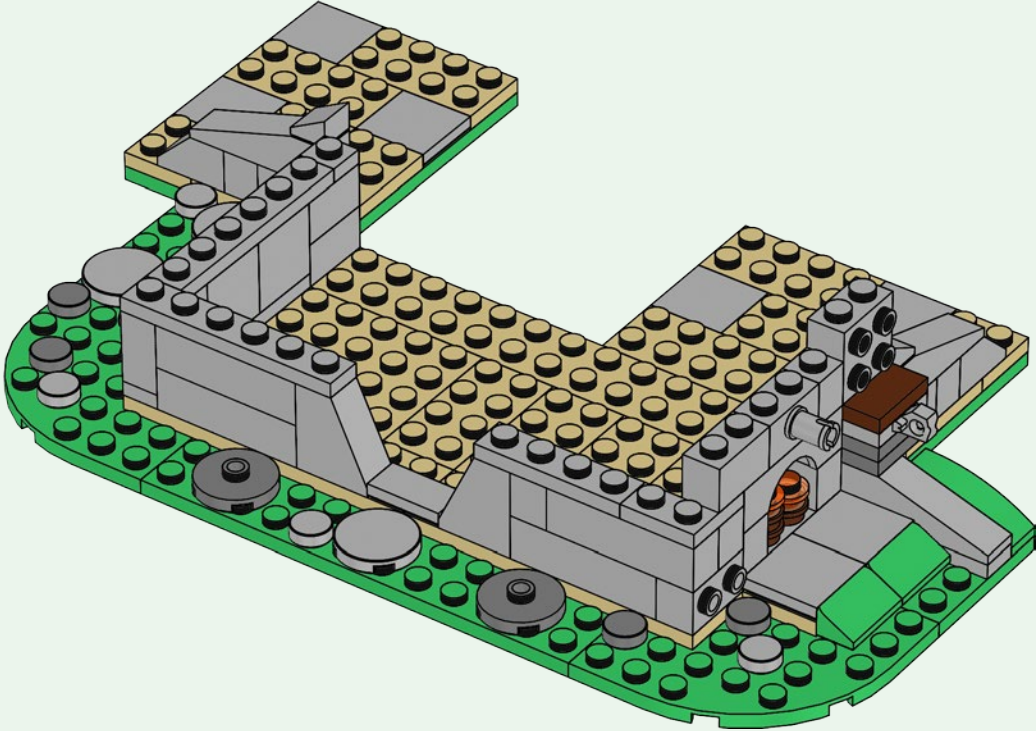

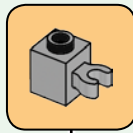
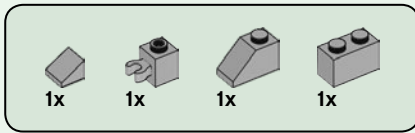

33

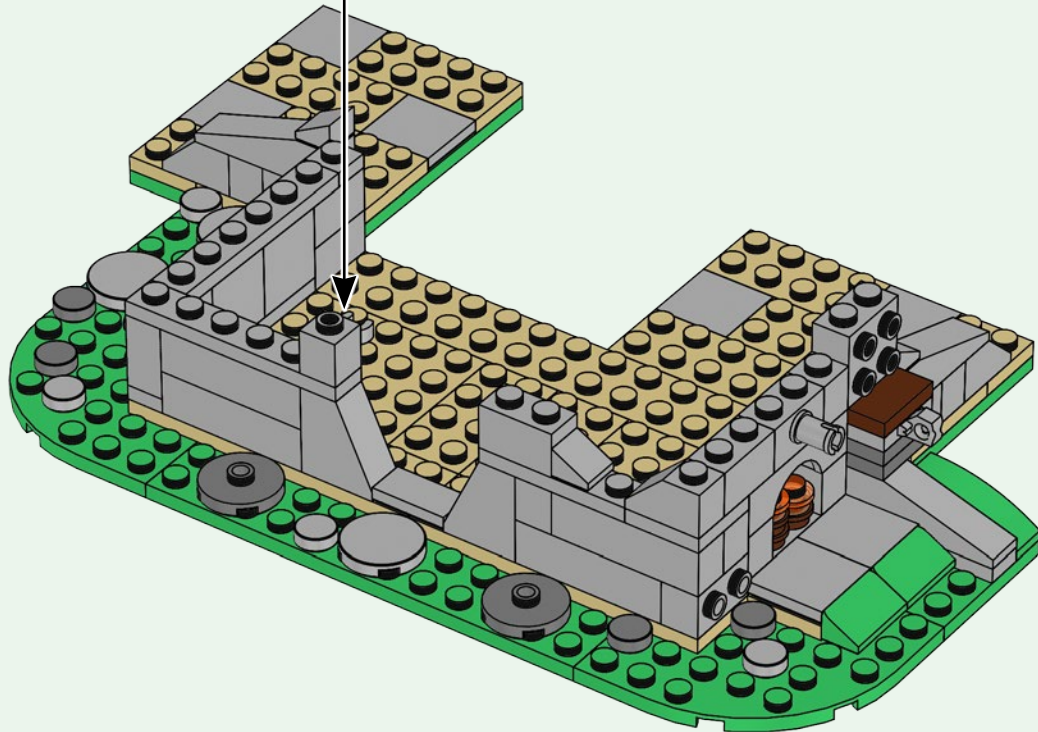

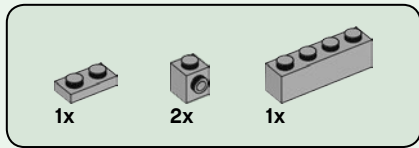

34

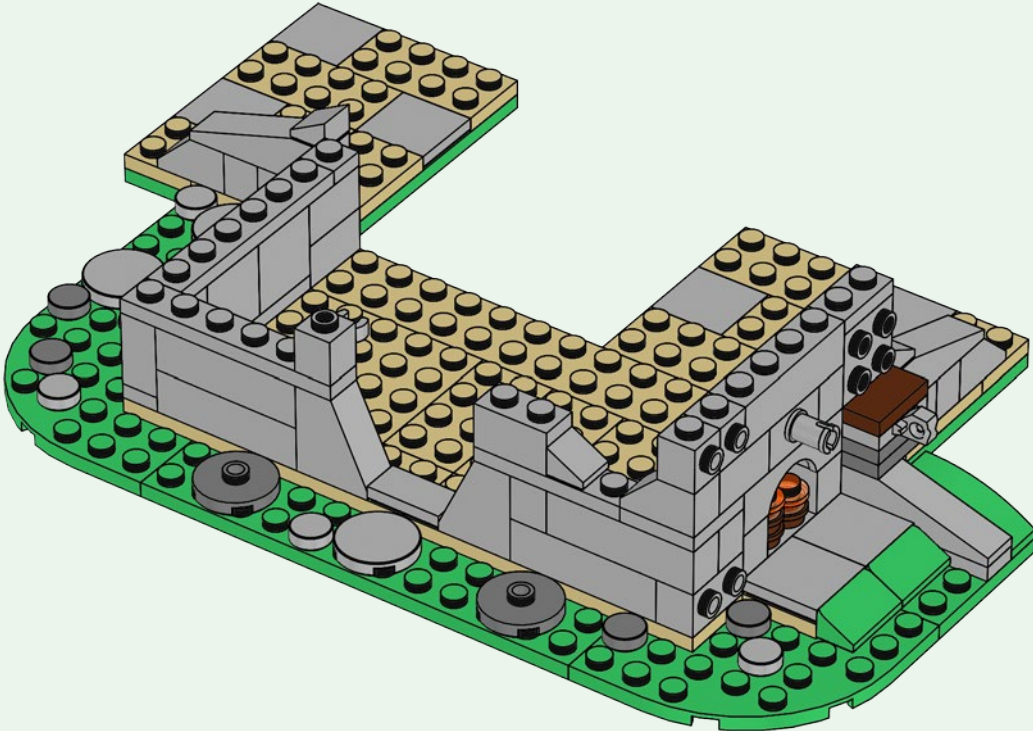

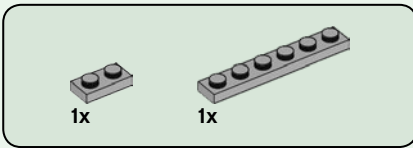

35

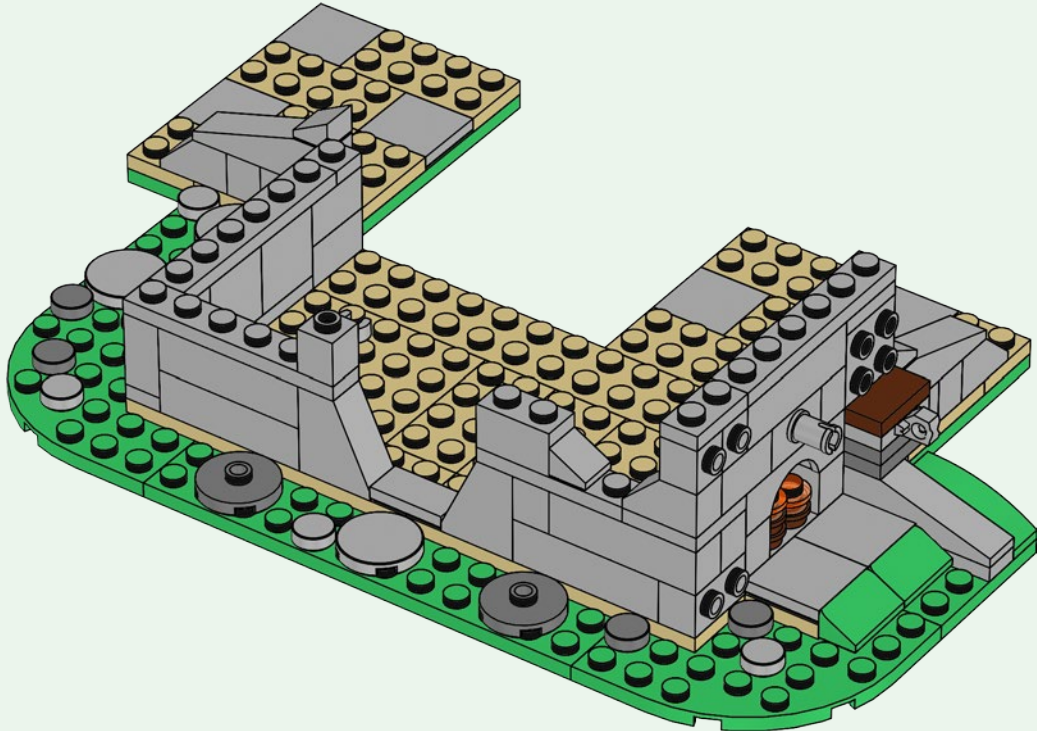

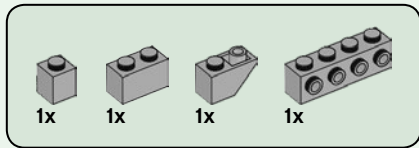

36

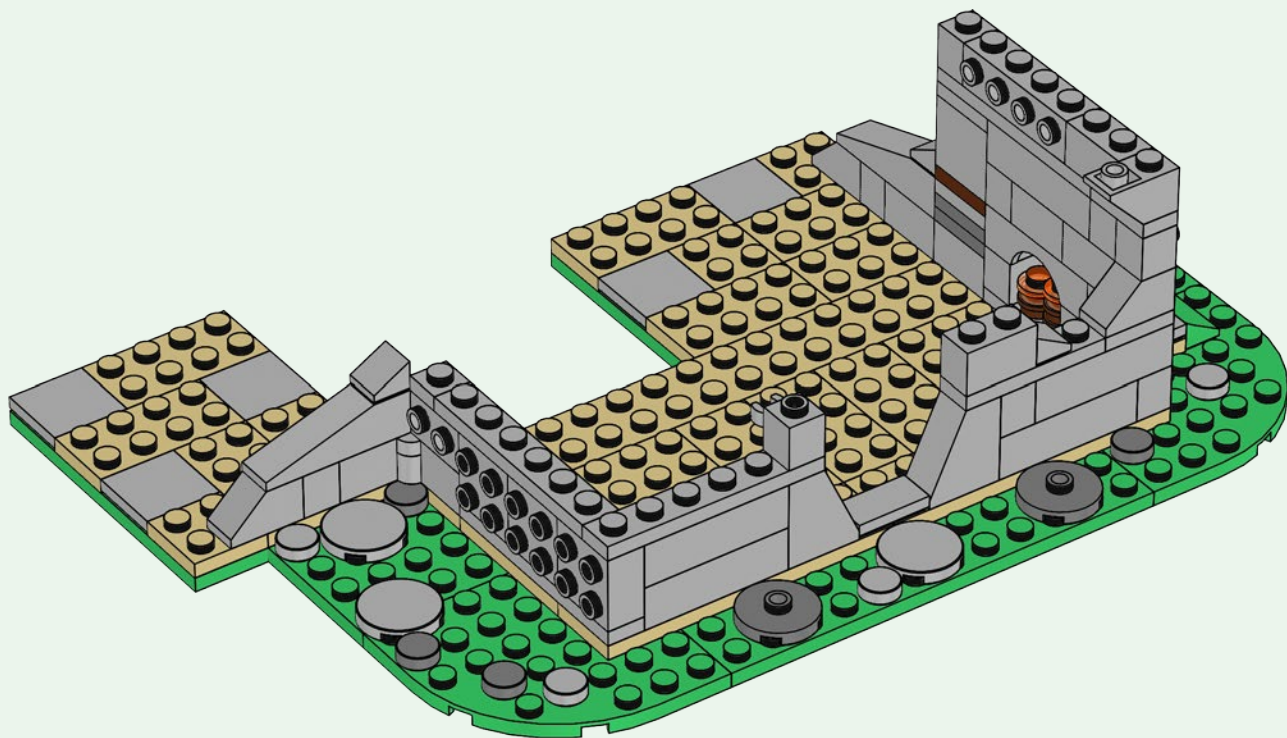

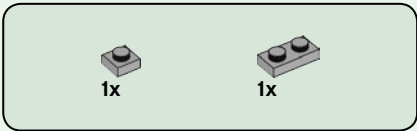

37

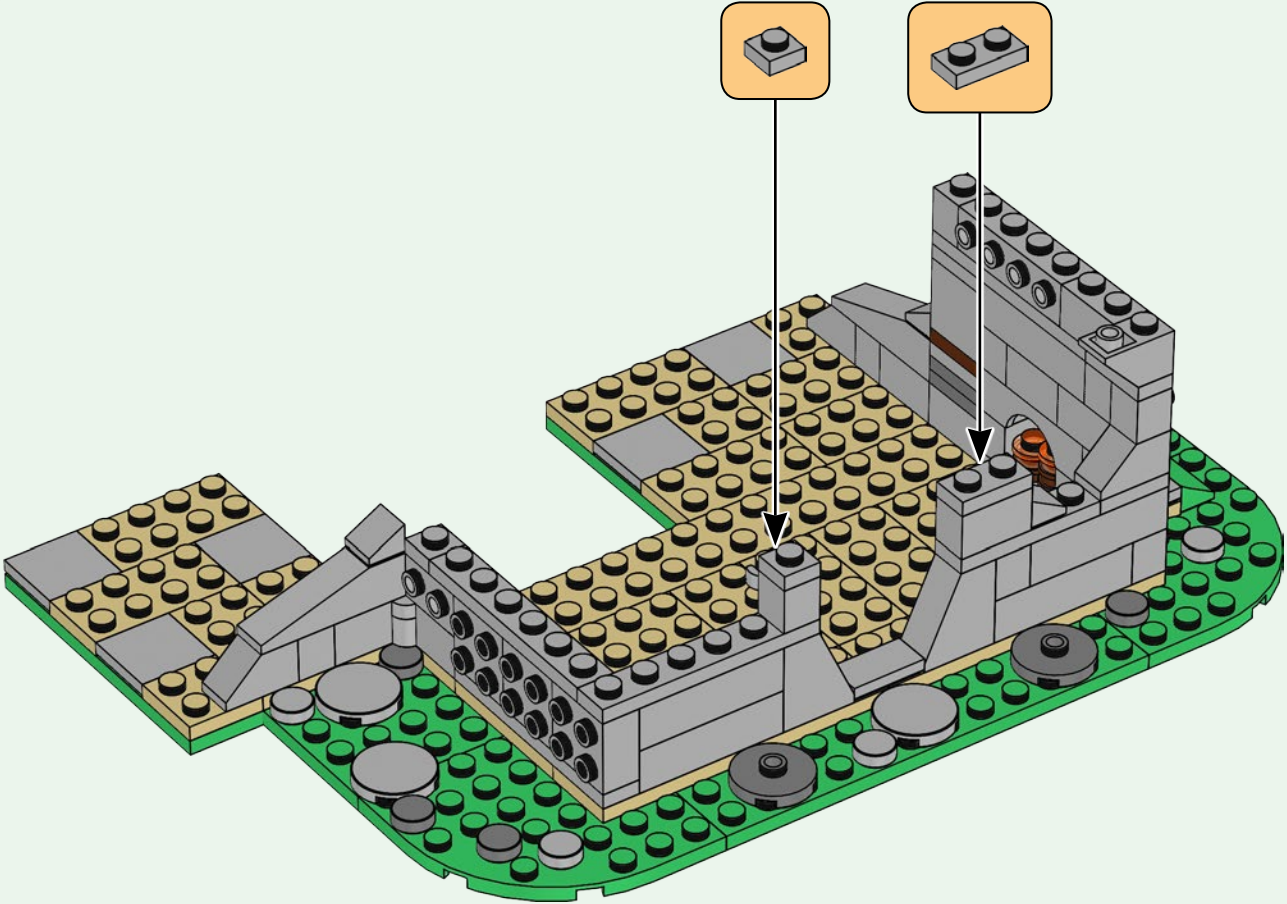

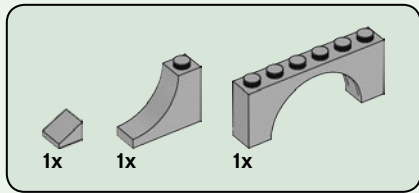

38

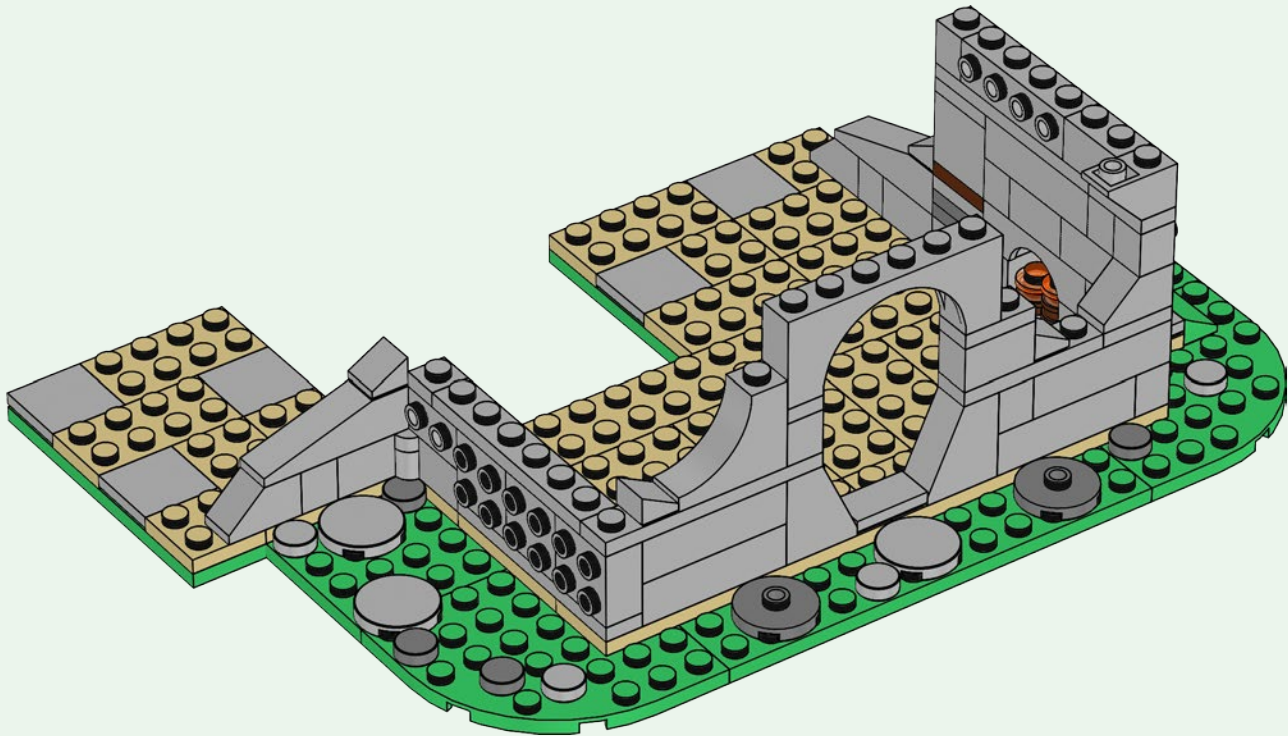

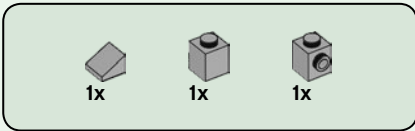

39

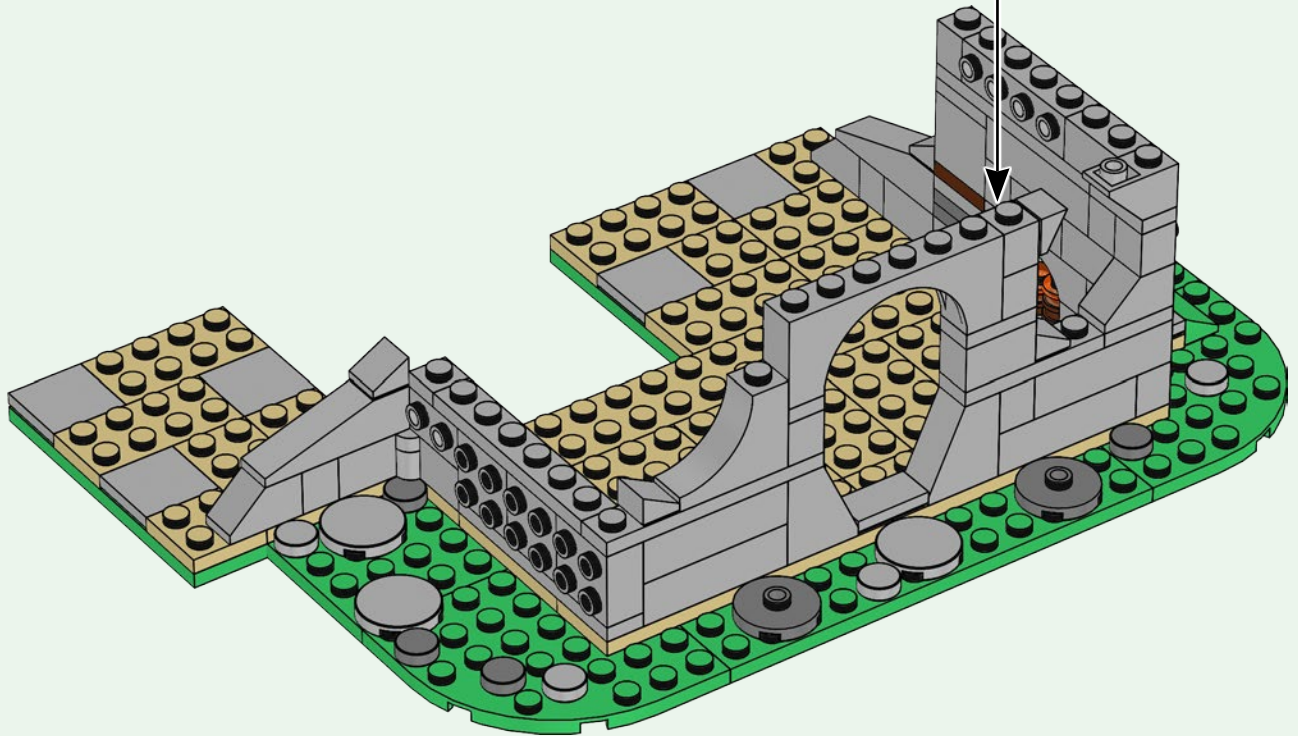
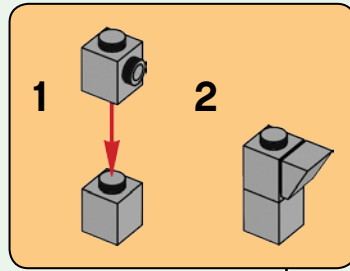

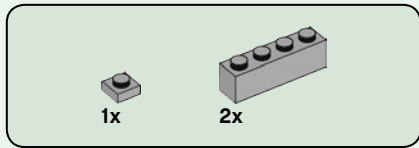

40

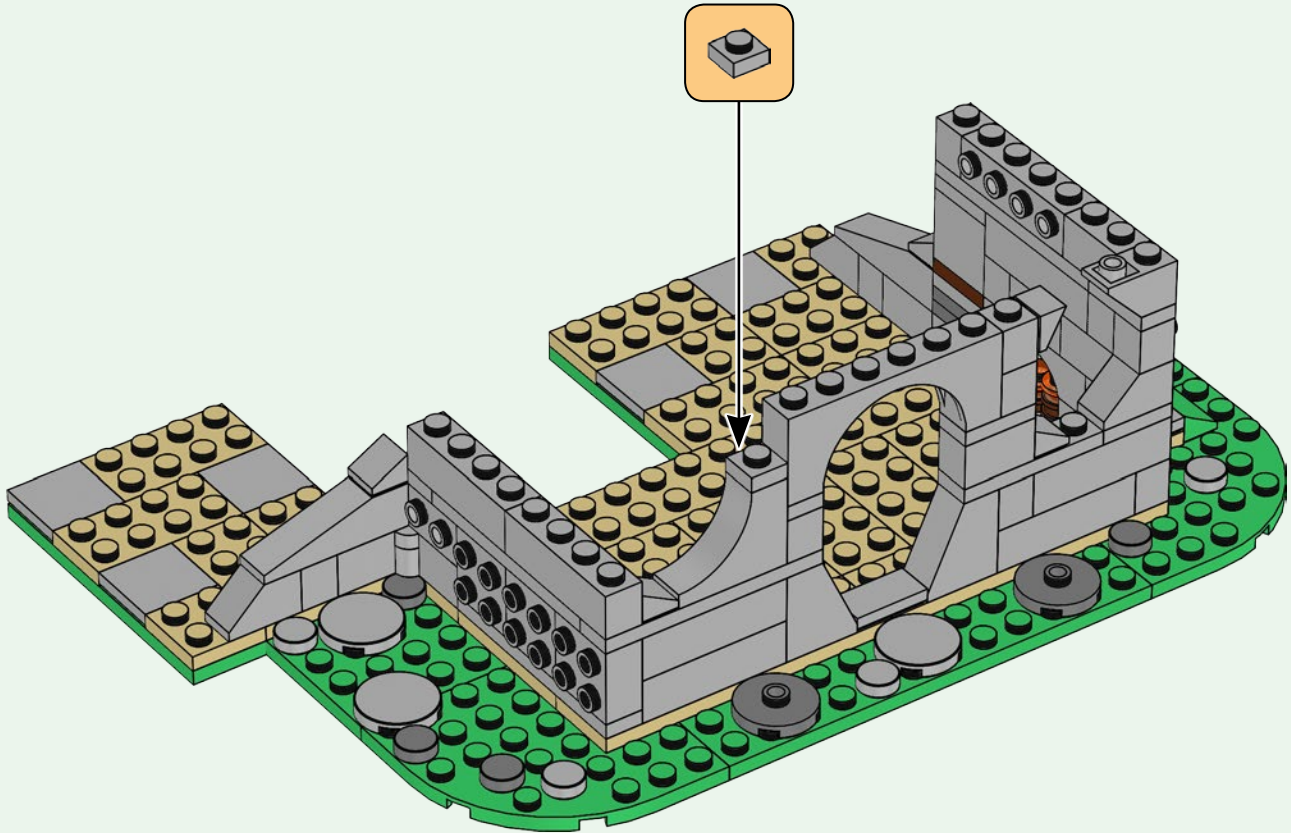

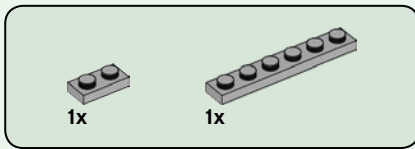

41

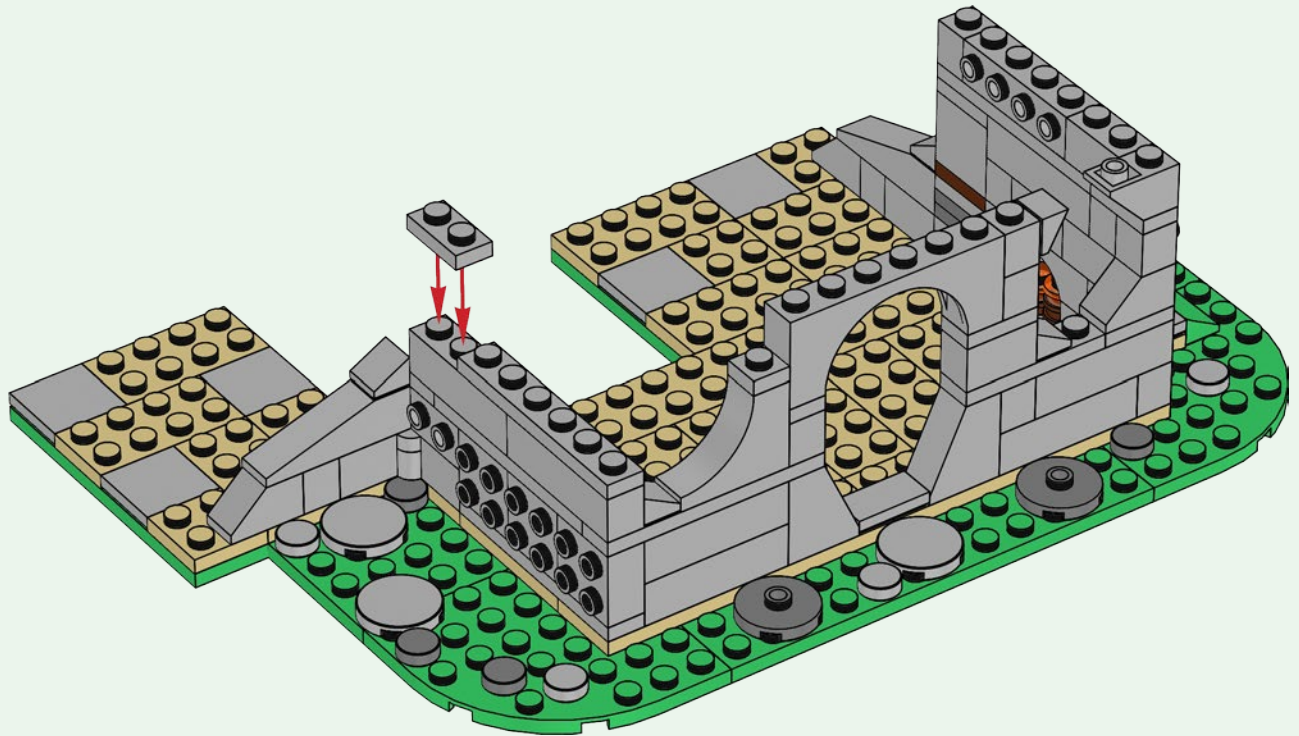

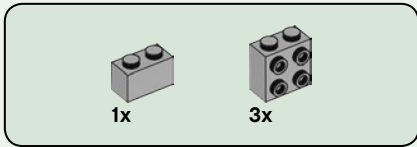

42

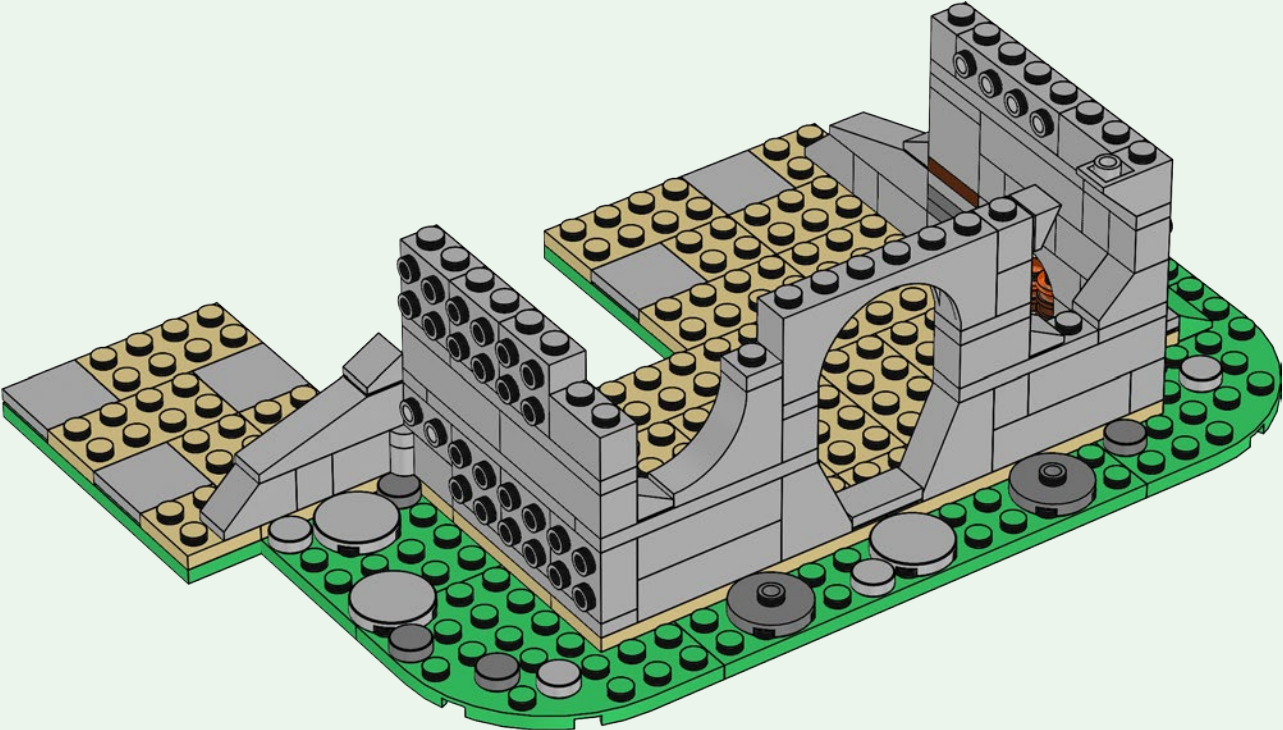

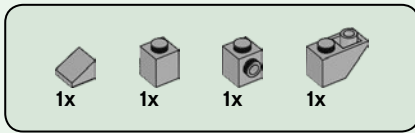

43

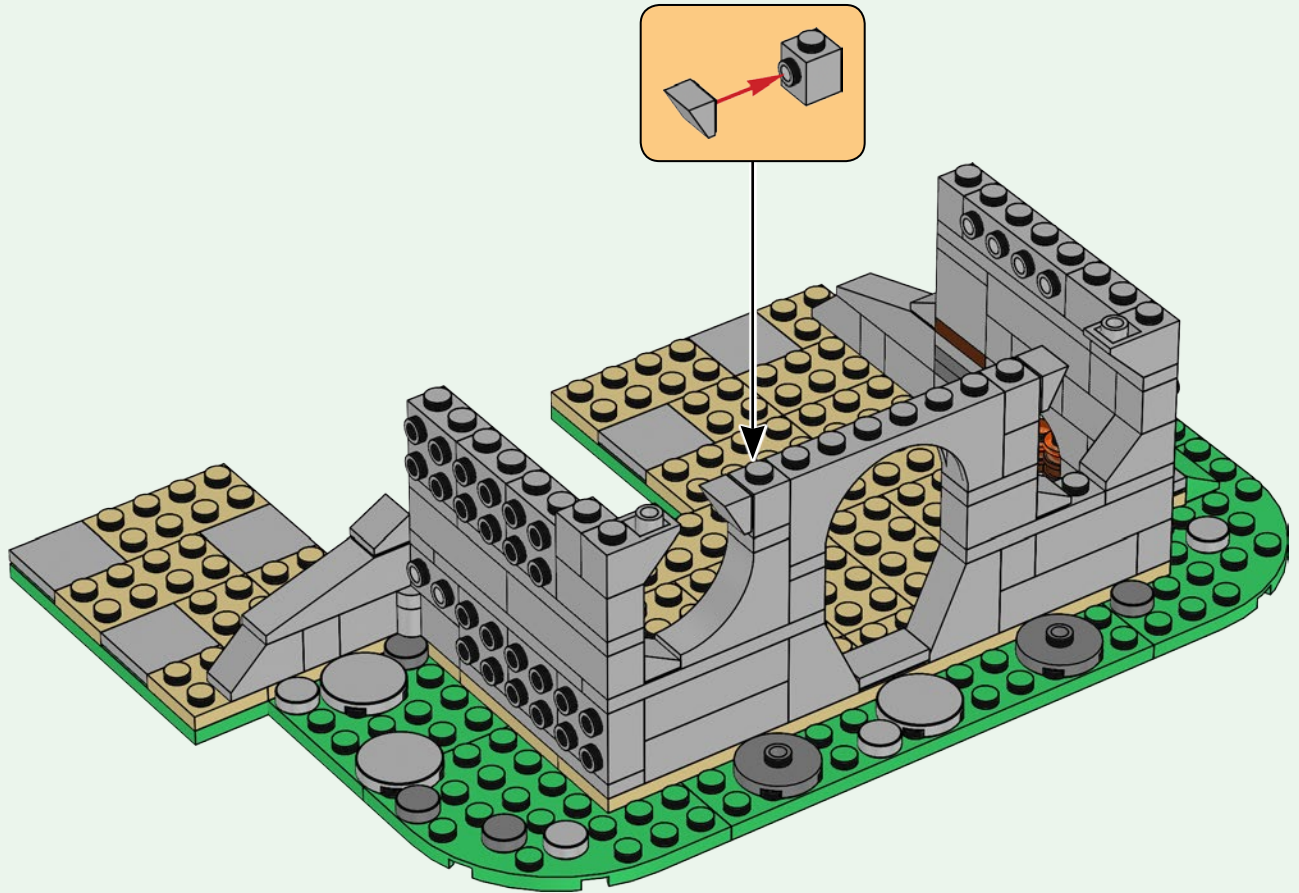

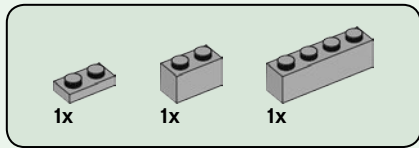

44

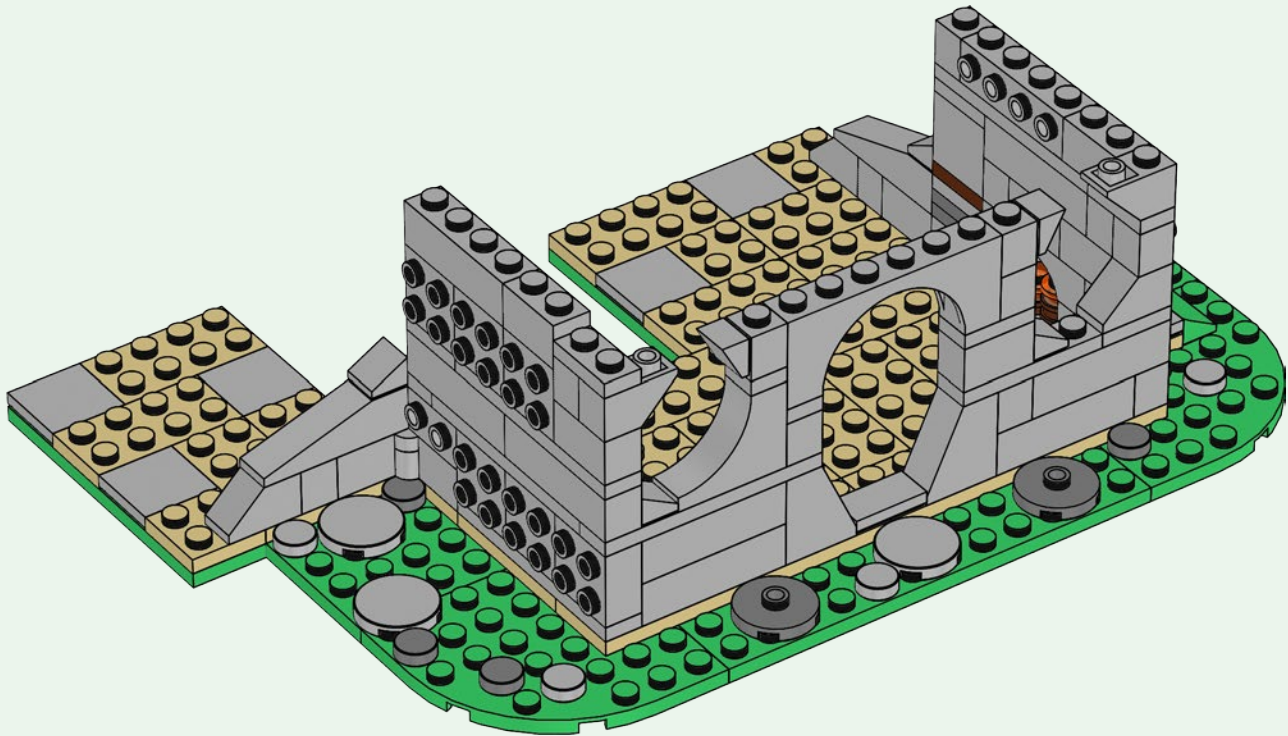

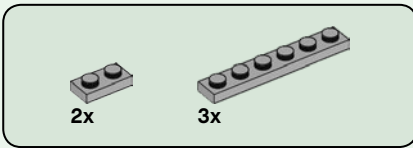

45

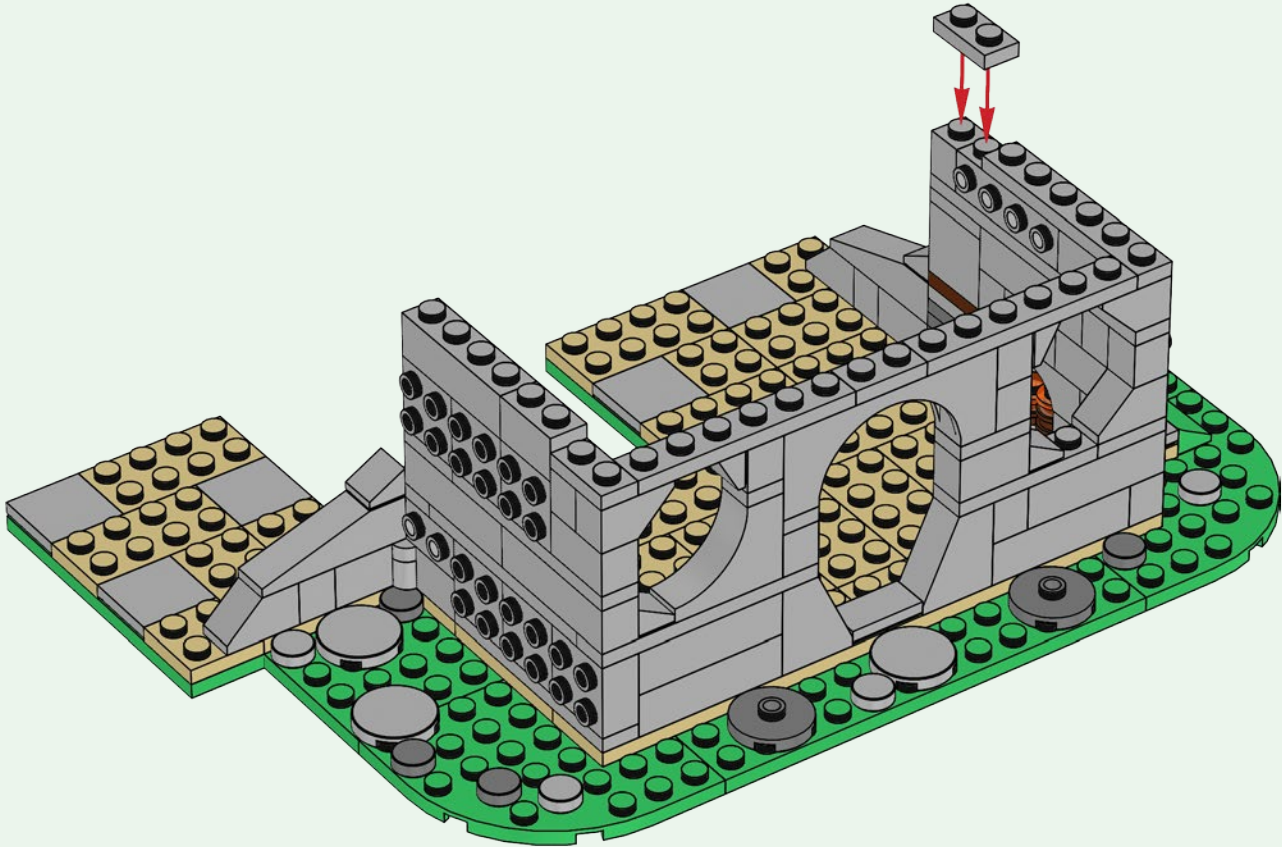

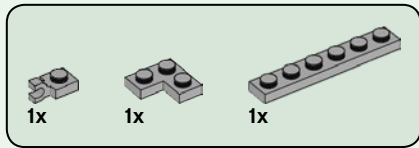

46

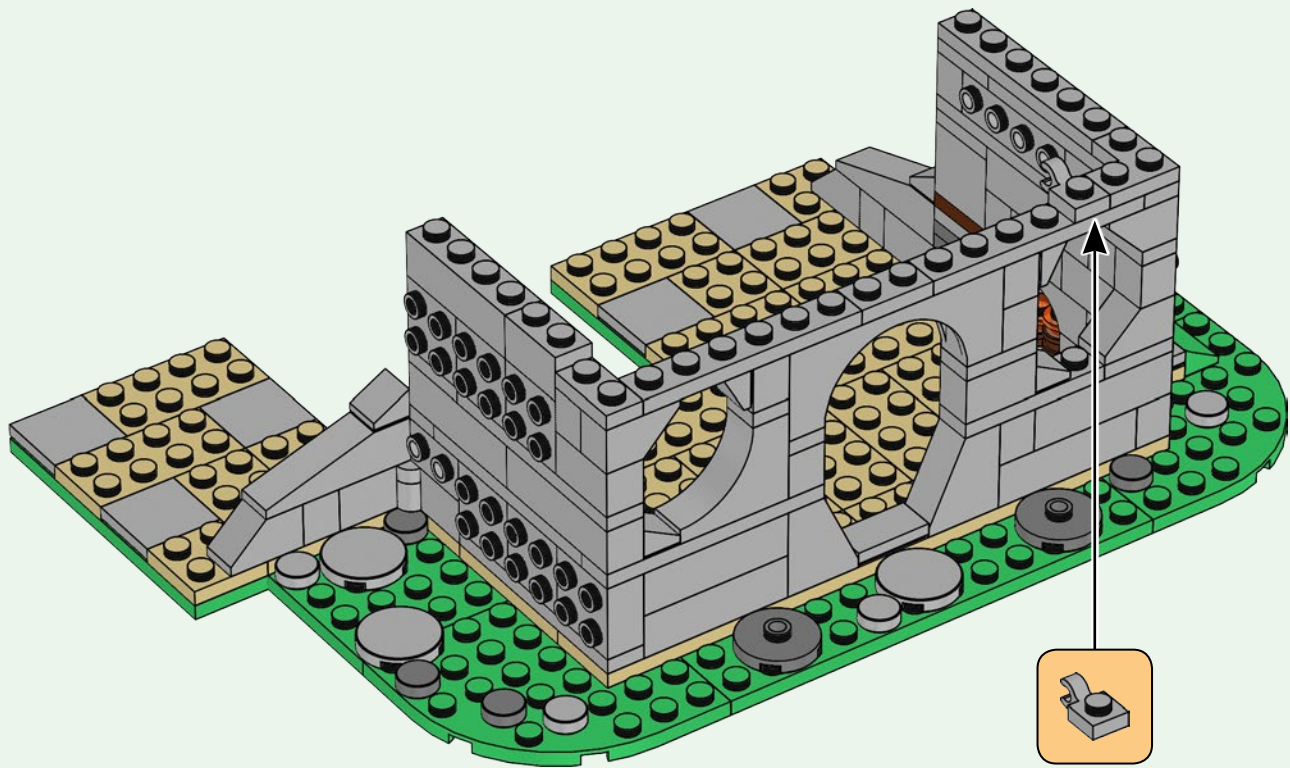

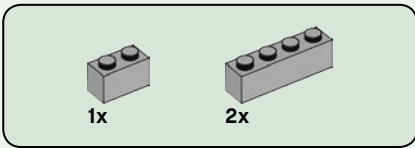

47

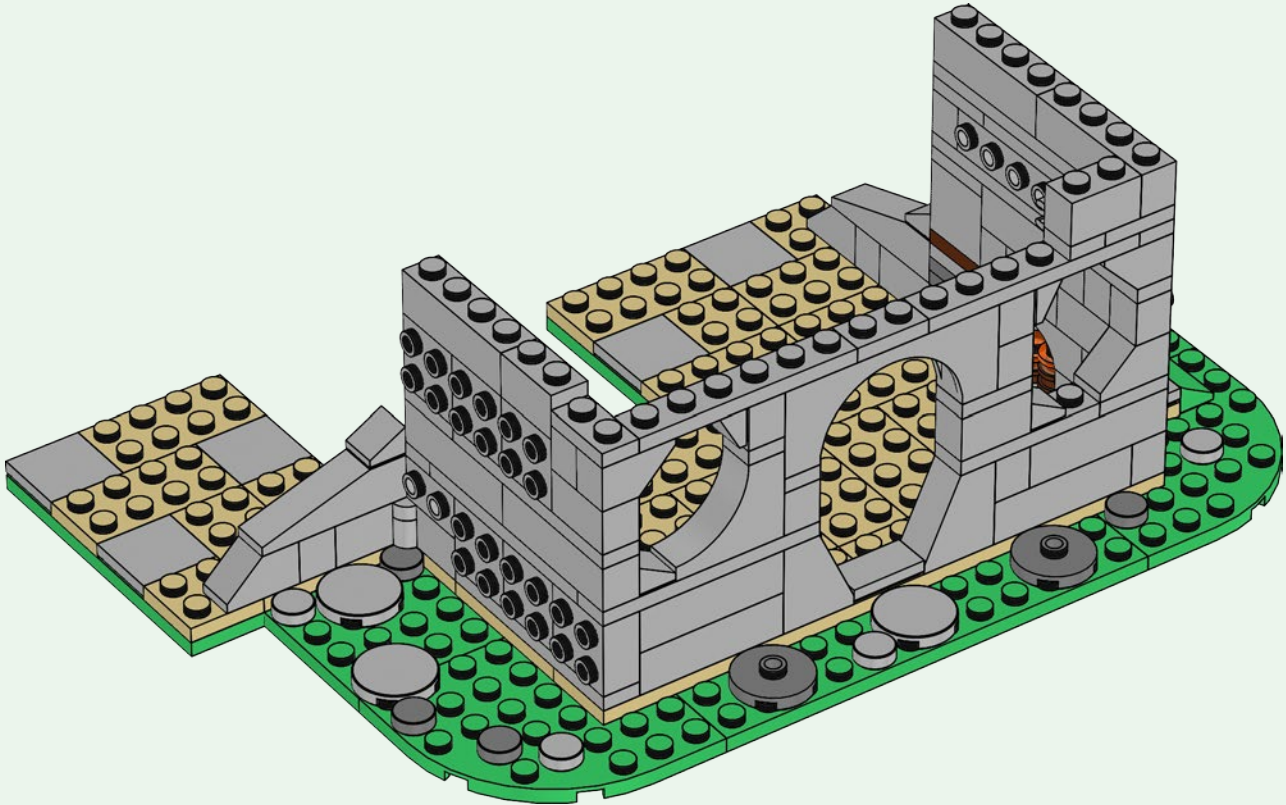

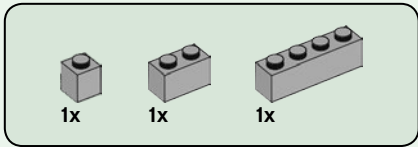

48

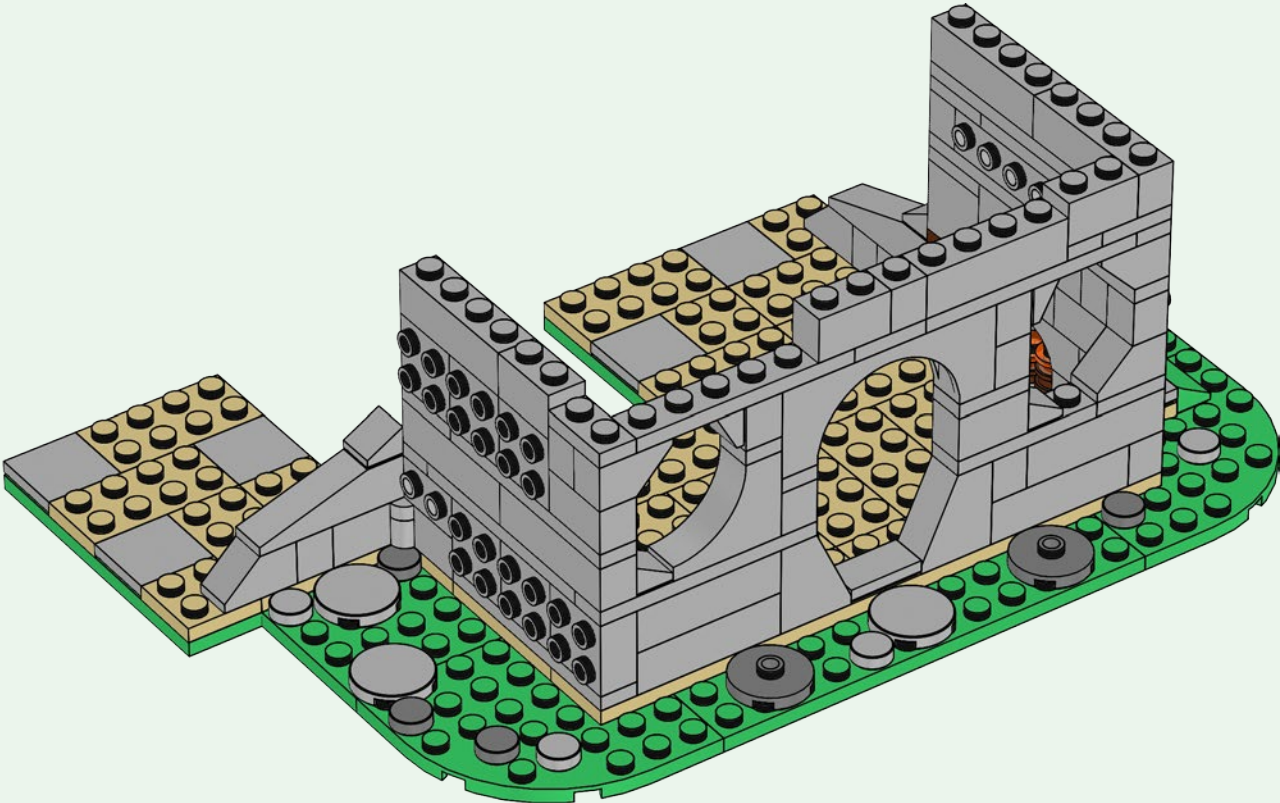

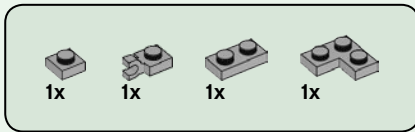

49

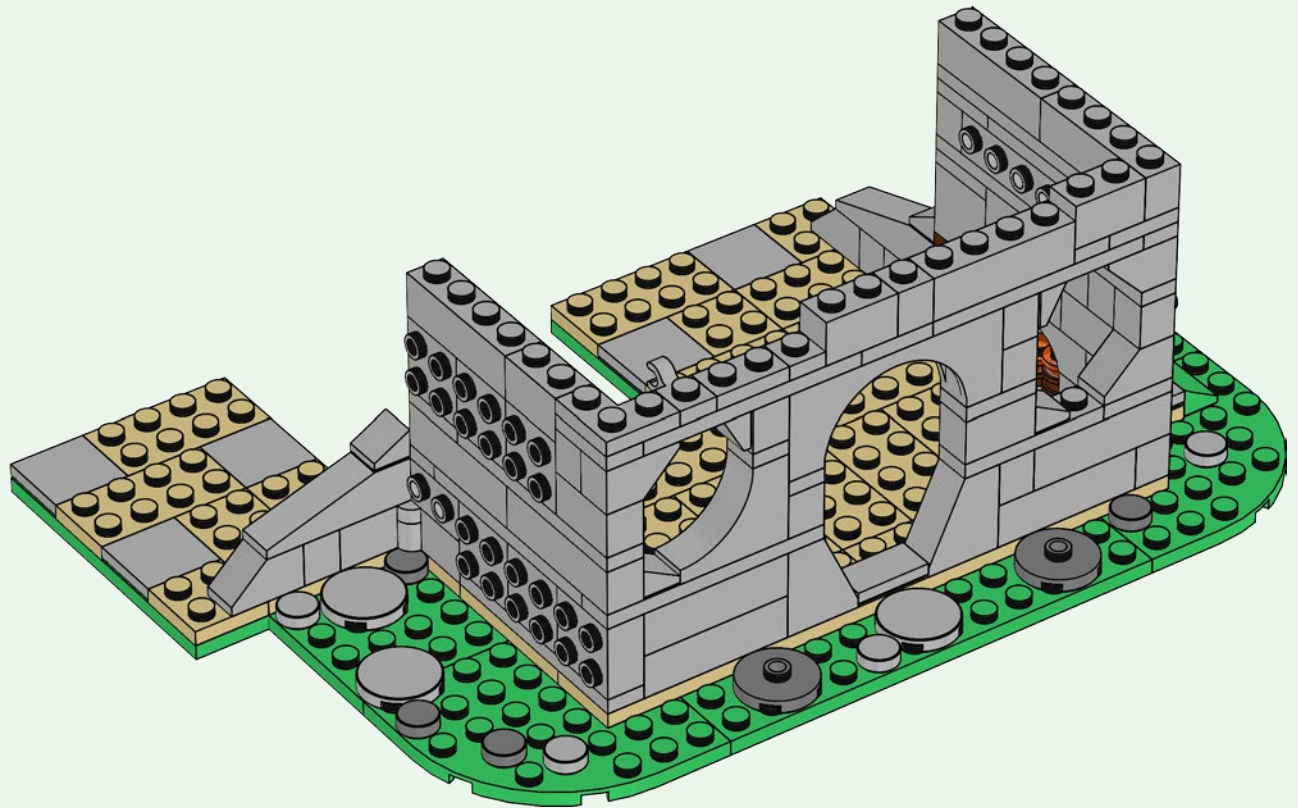

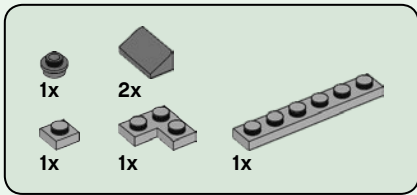

50

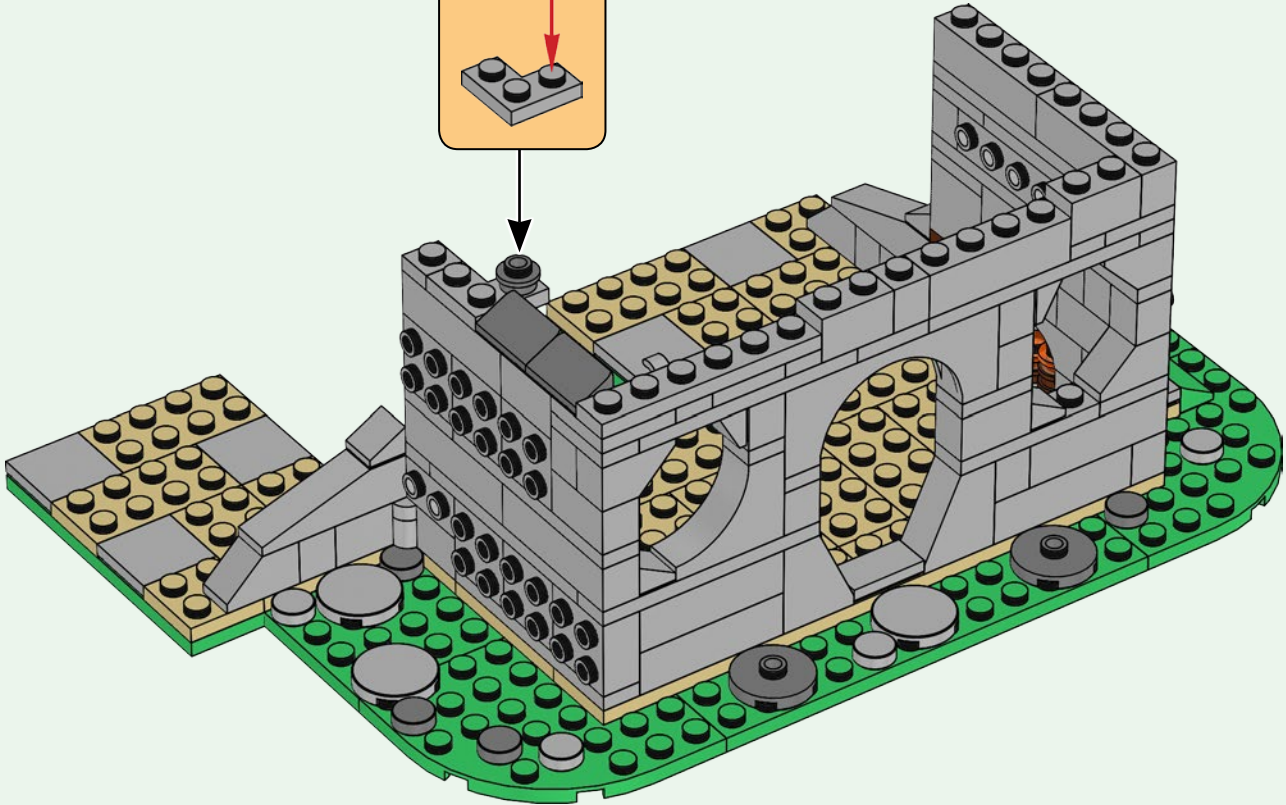
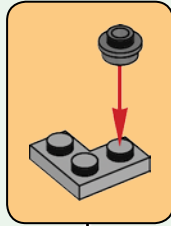

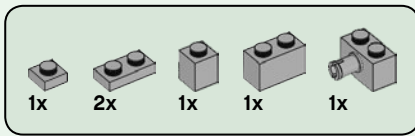

51

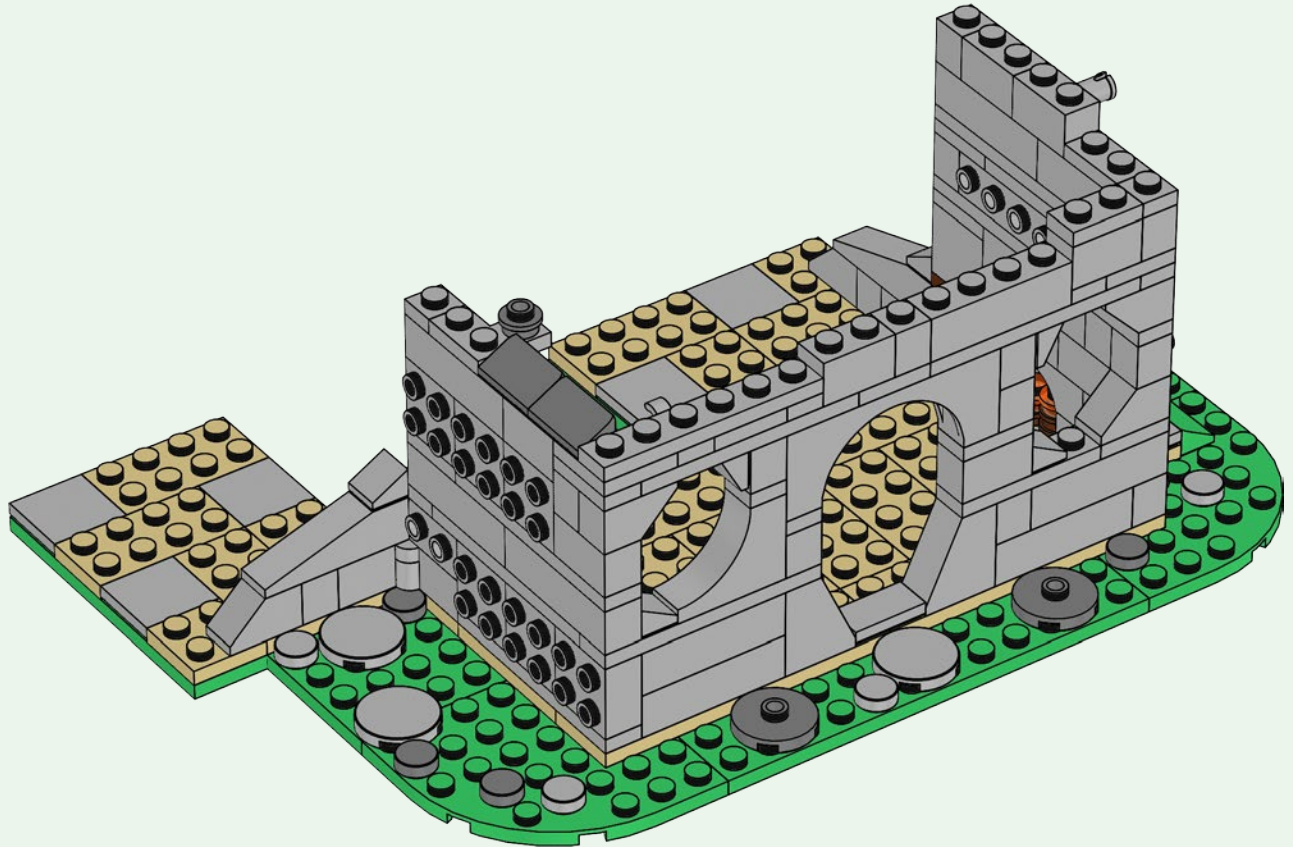

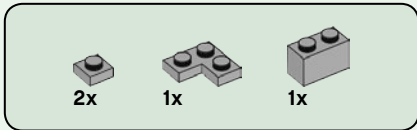

52

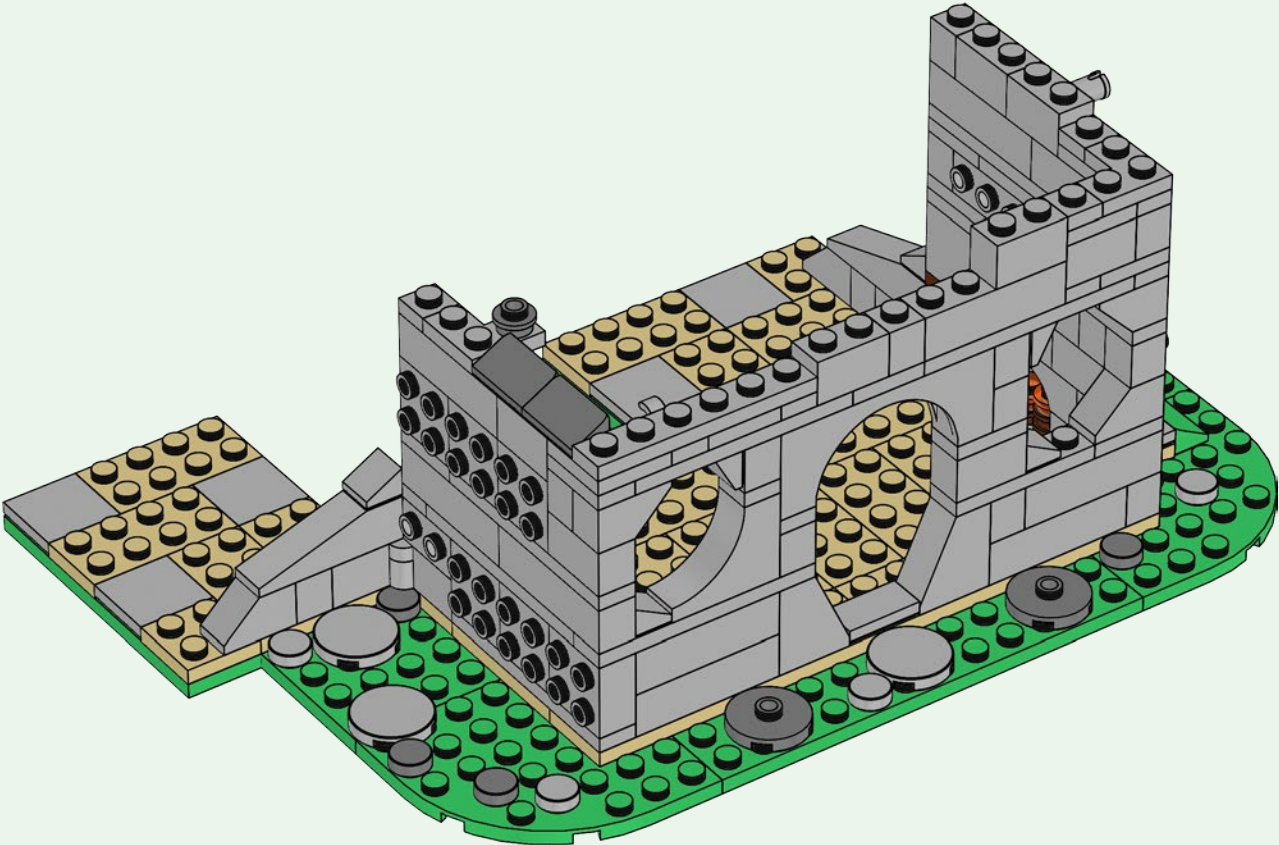

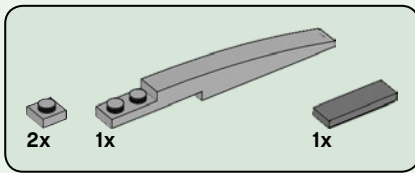

53

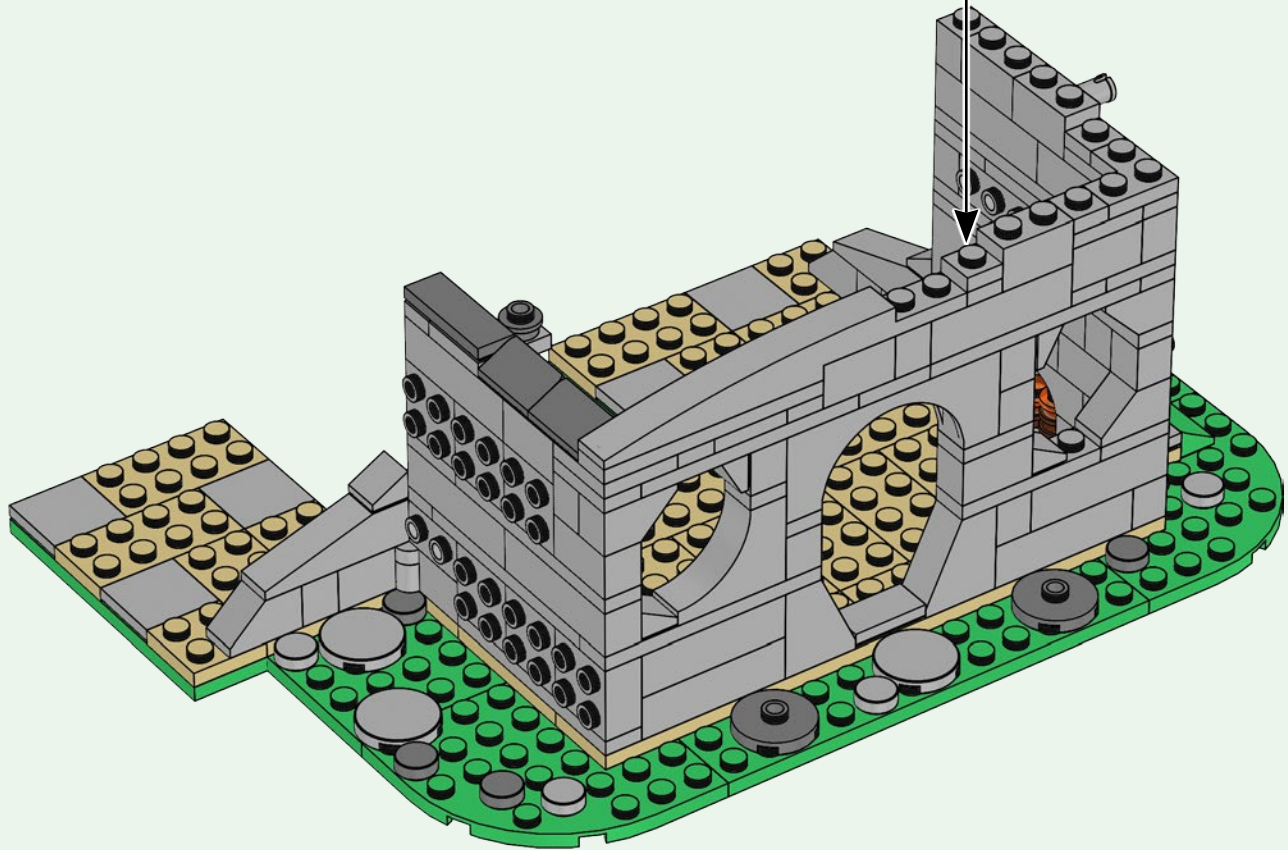
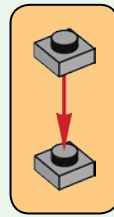



1x

54

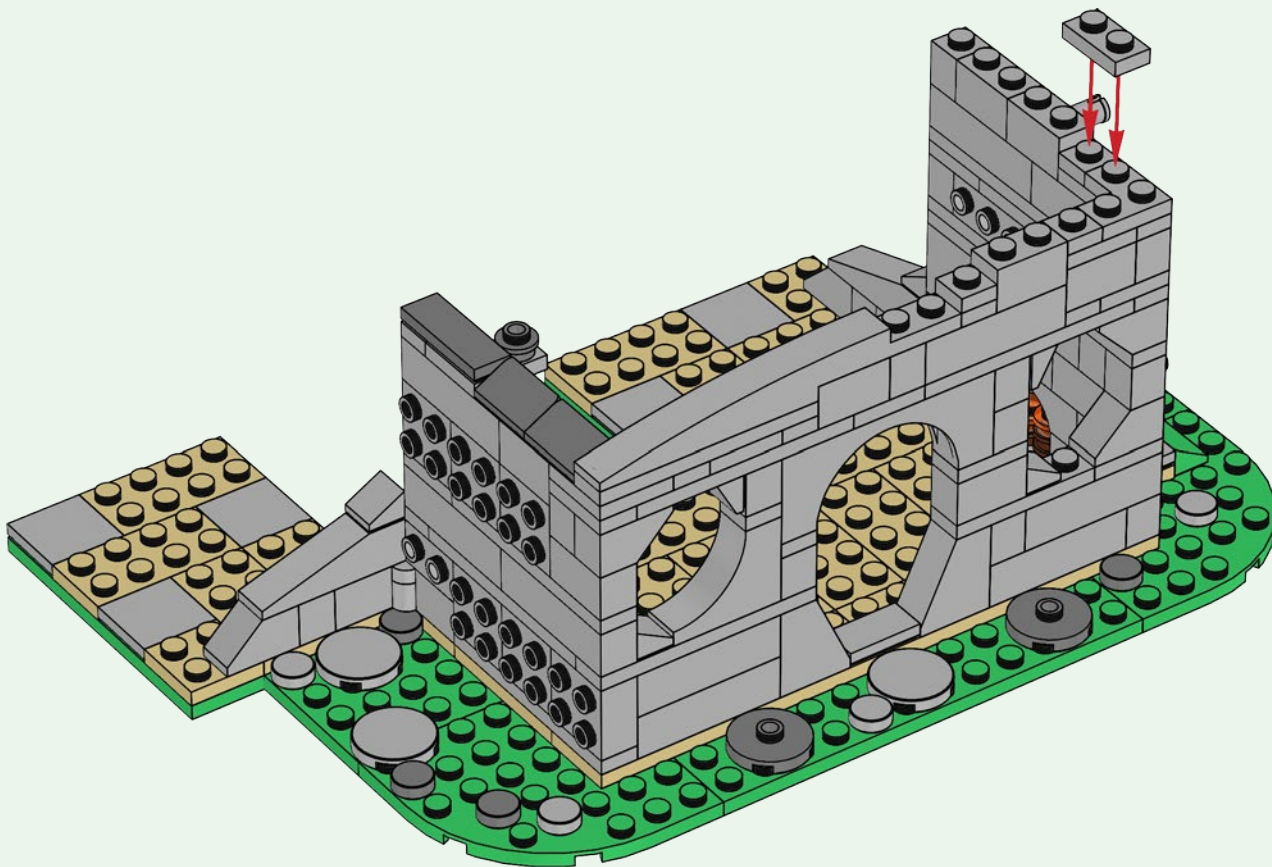

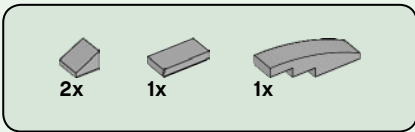

55

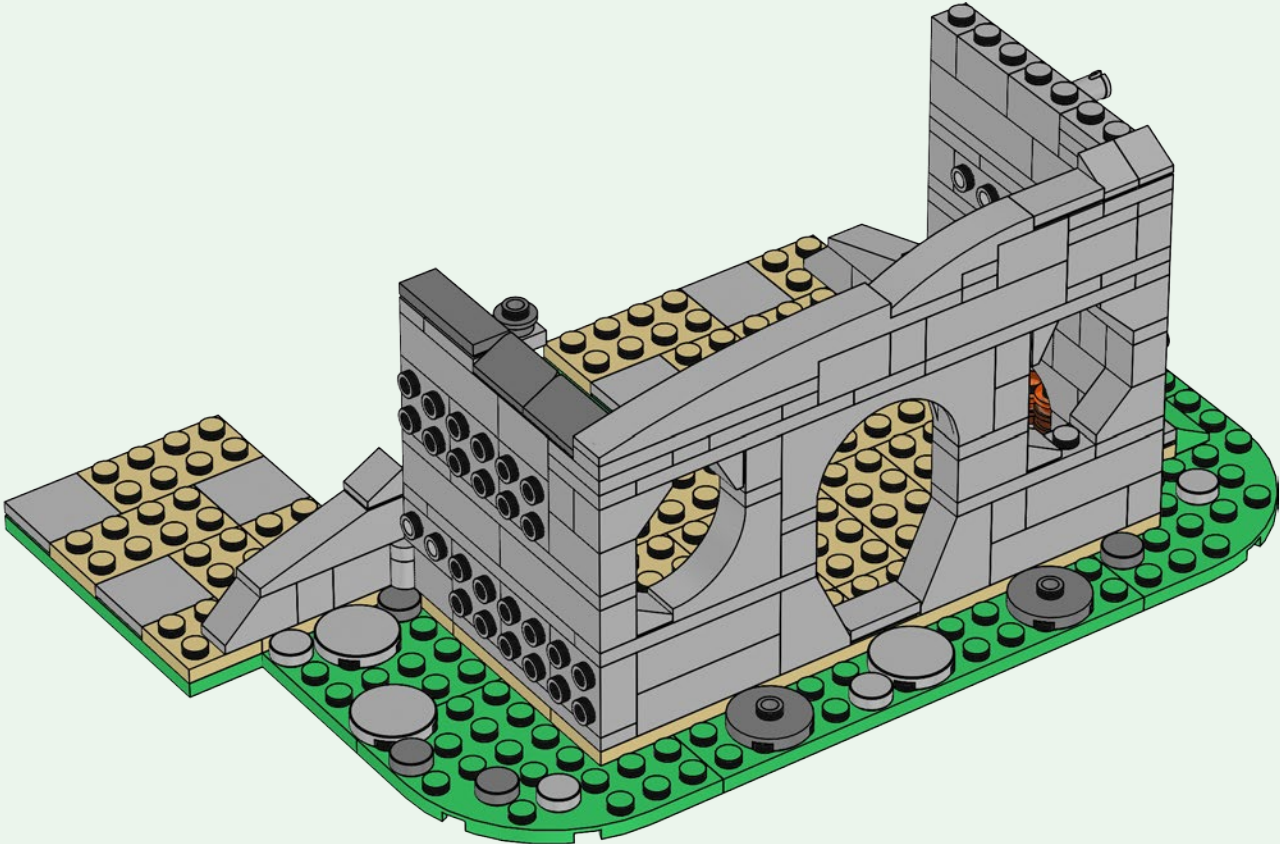



56

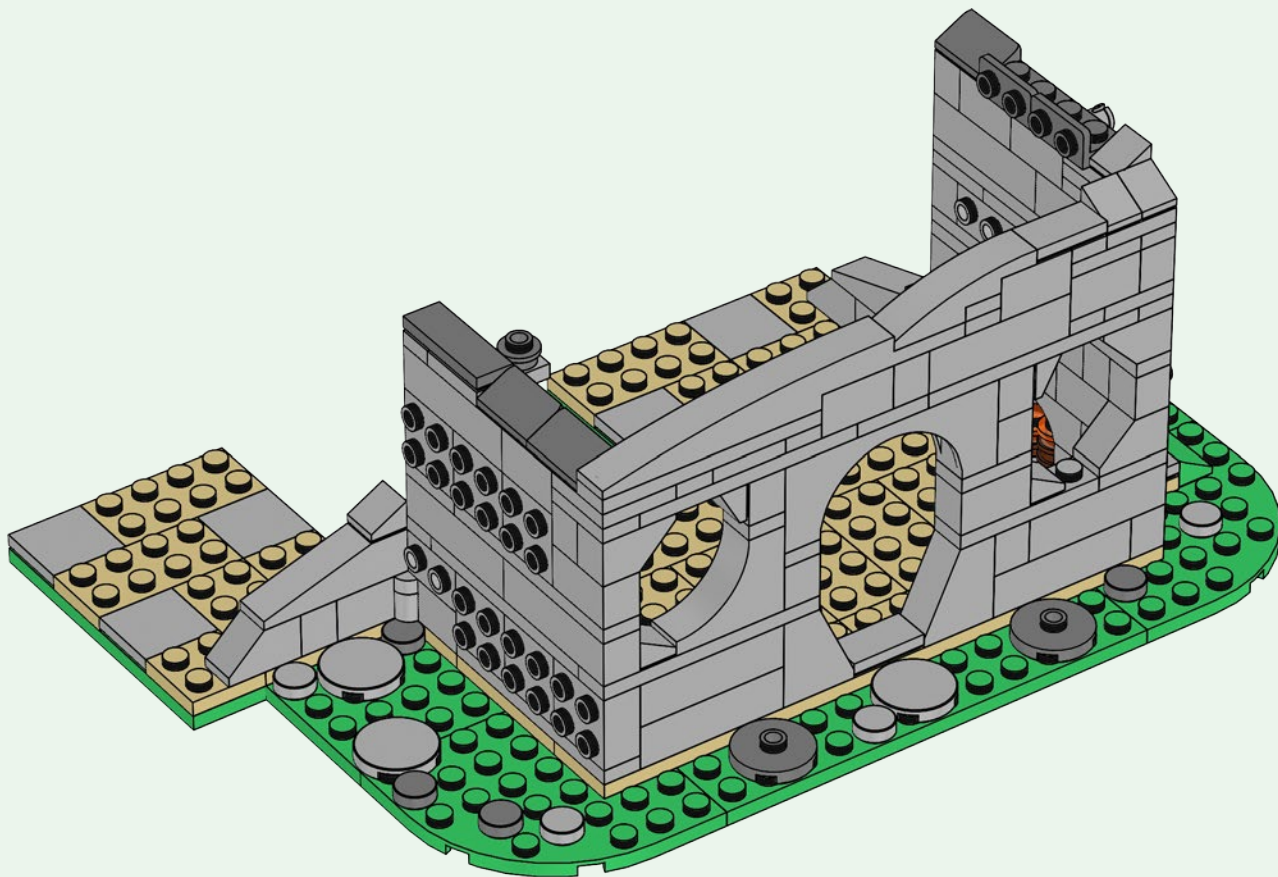

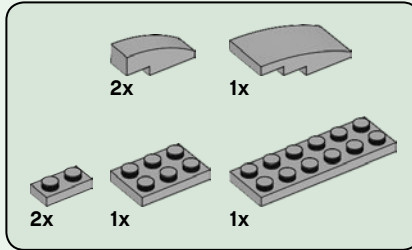
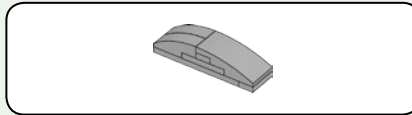
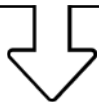
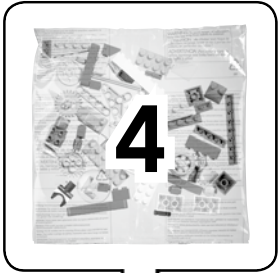

57

1

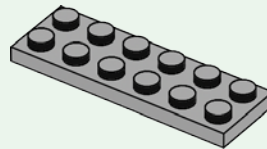

2

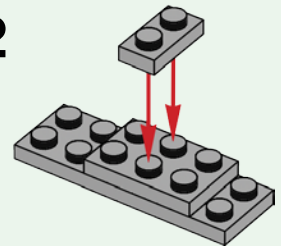

3

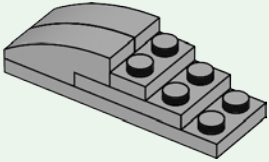

4

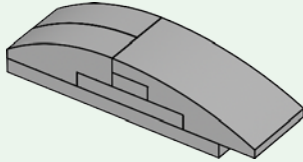

5

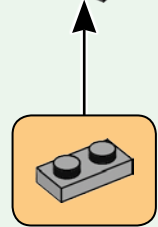
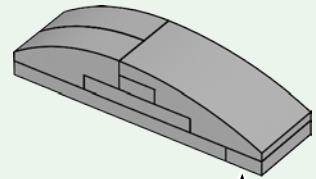

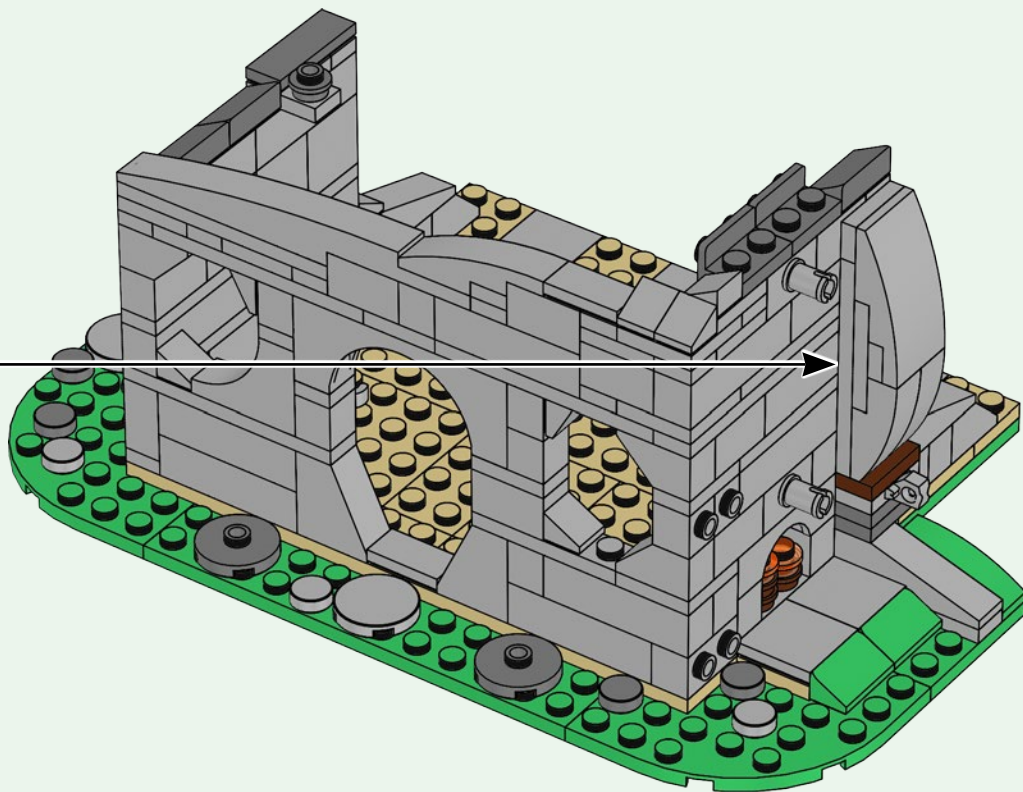

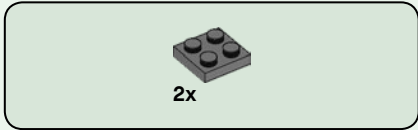
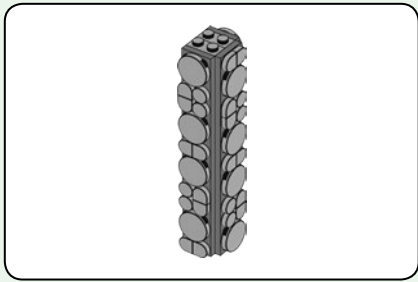

58

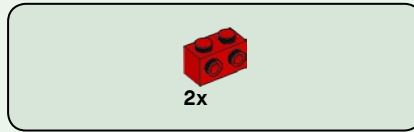
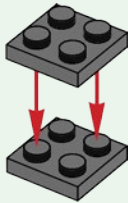

59

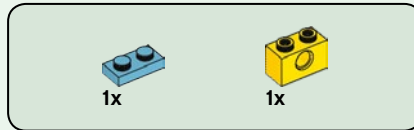

60

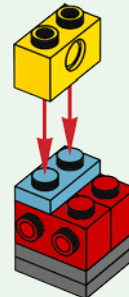

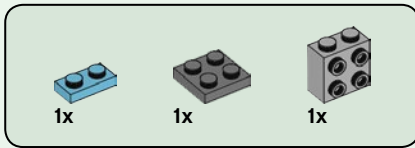

61

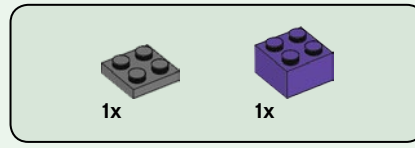
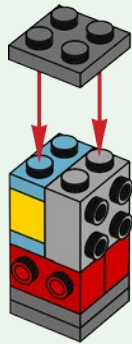

62





2x

63



1x



1x

64

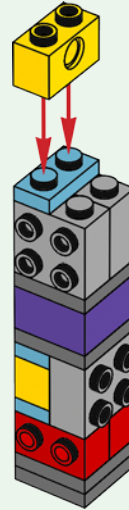

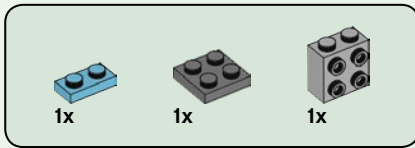

65

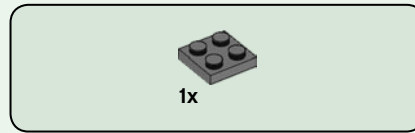
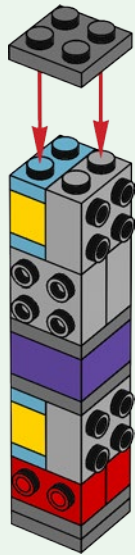

66





1x



1x

67

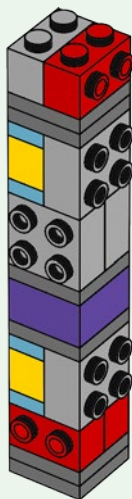

2x

68



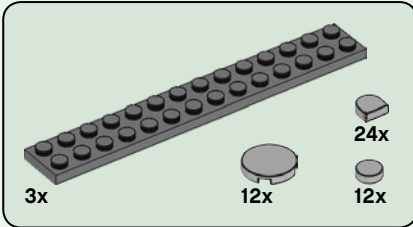
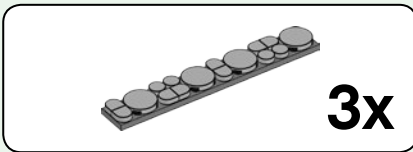

69

1

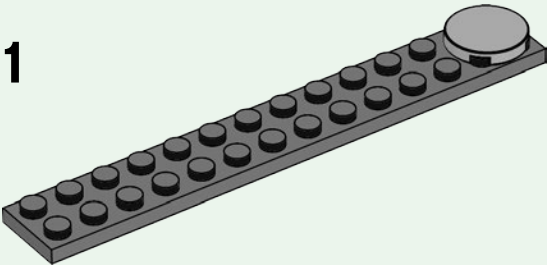

2

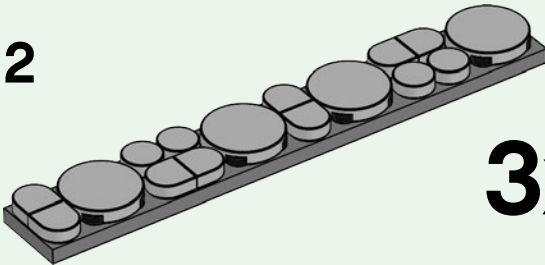

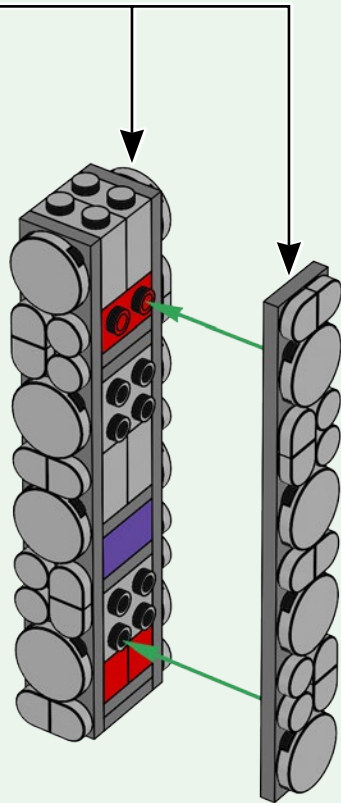

70

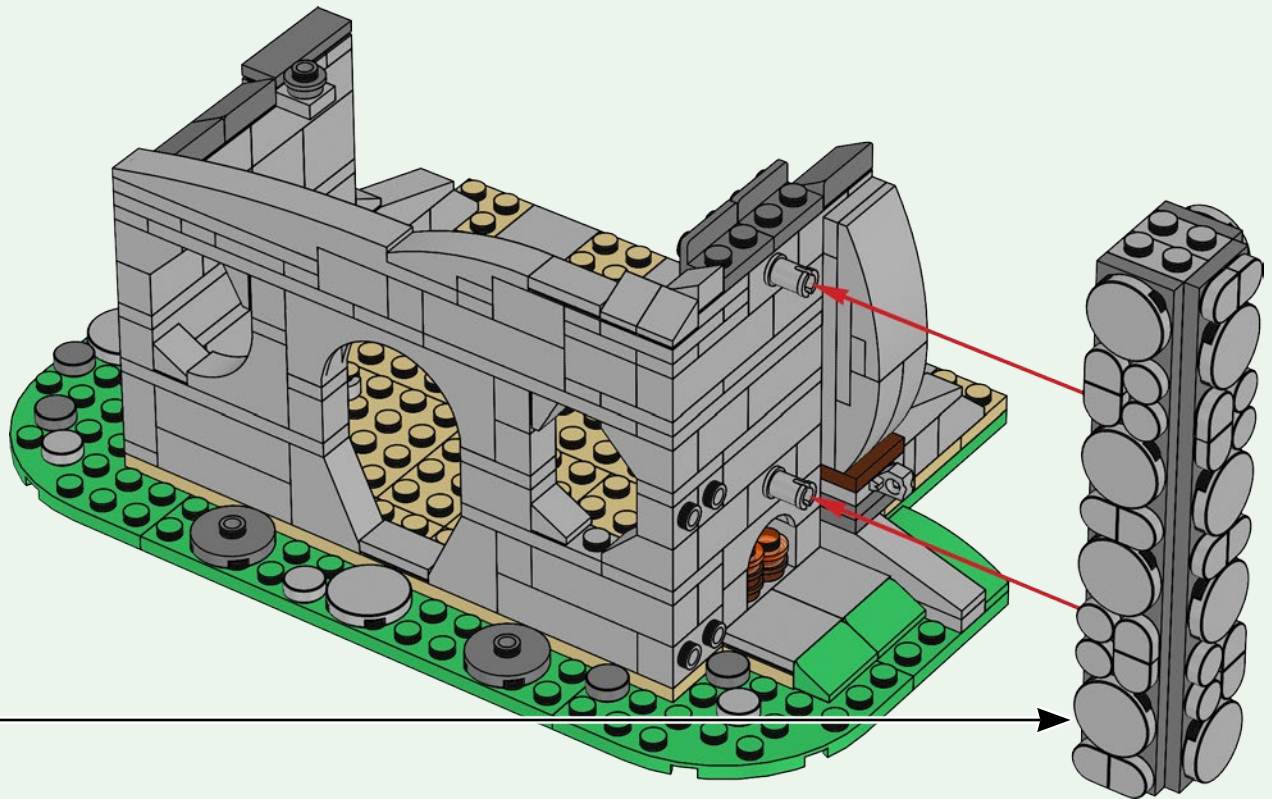

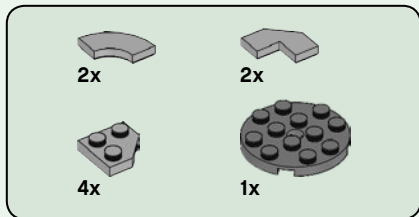

71

1



2

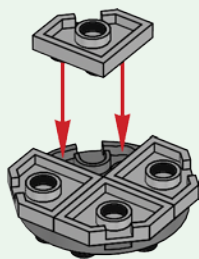

3

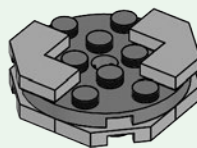

4

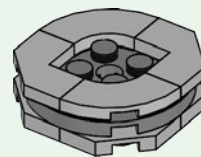

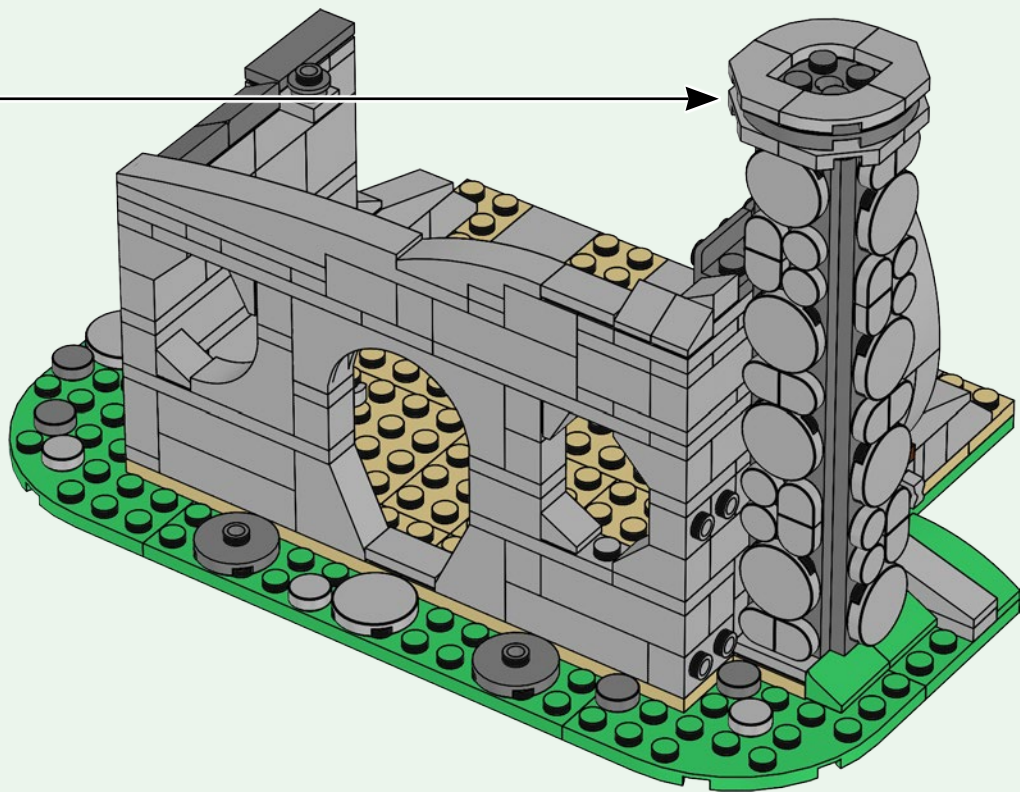

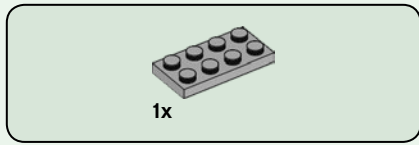

72

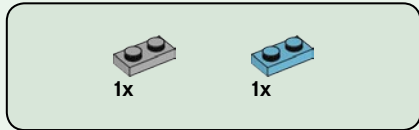
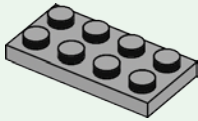

73

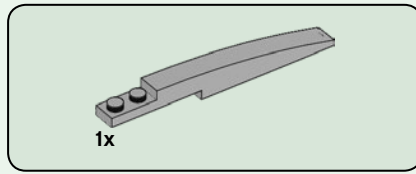
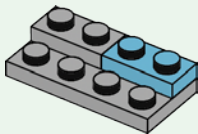

74

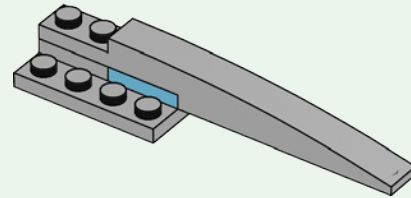

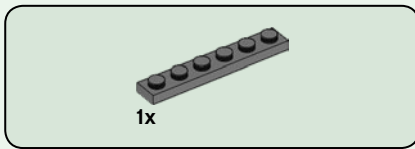

75

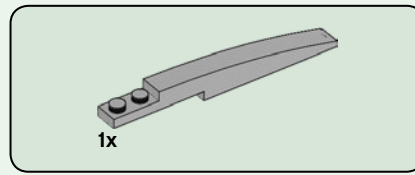
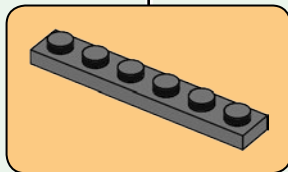
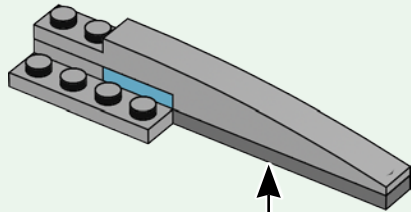

76

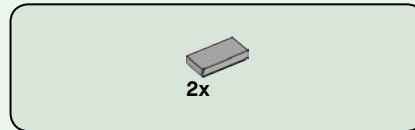
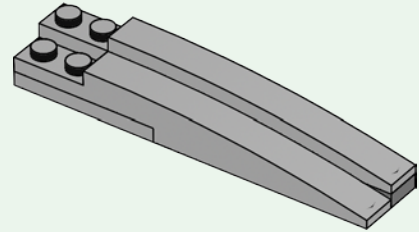

77

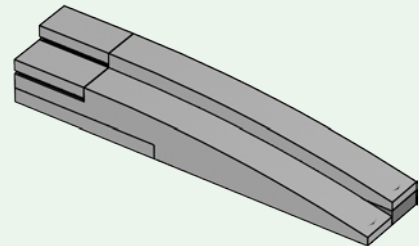

78

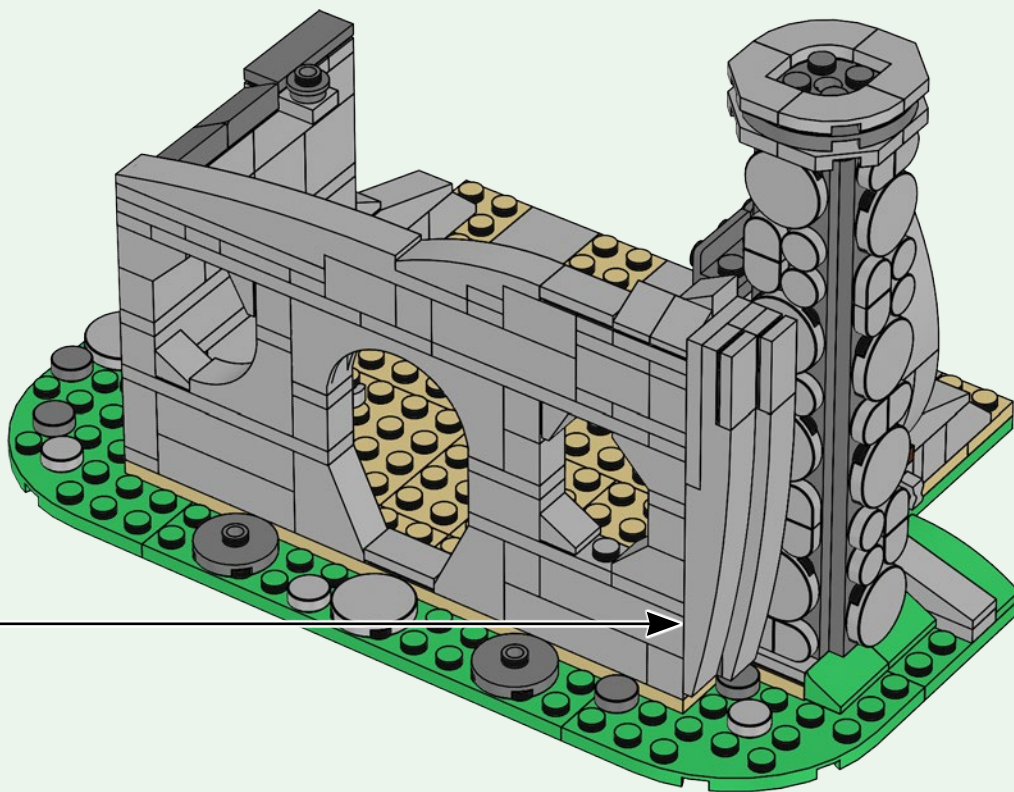

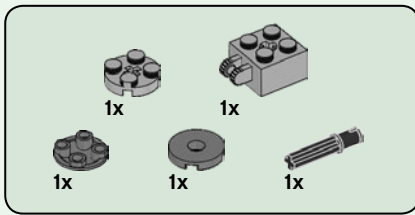

79

1

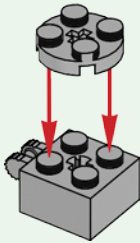

2

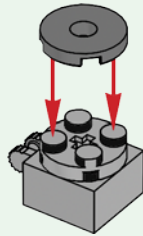

3

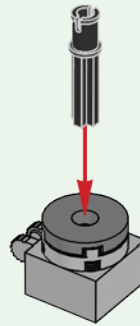

4



80

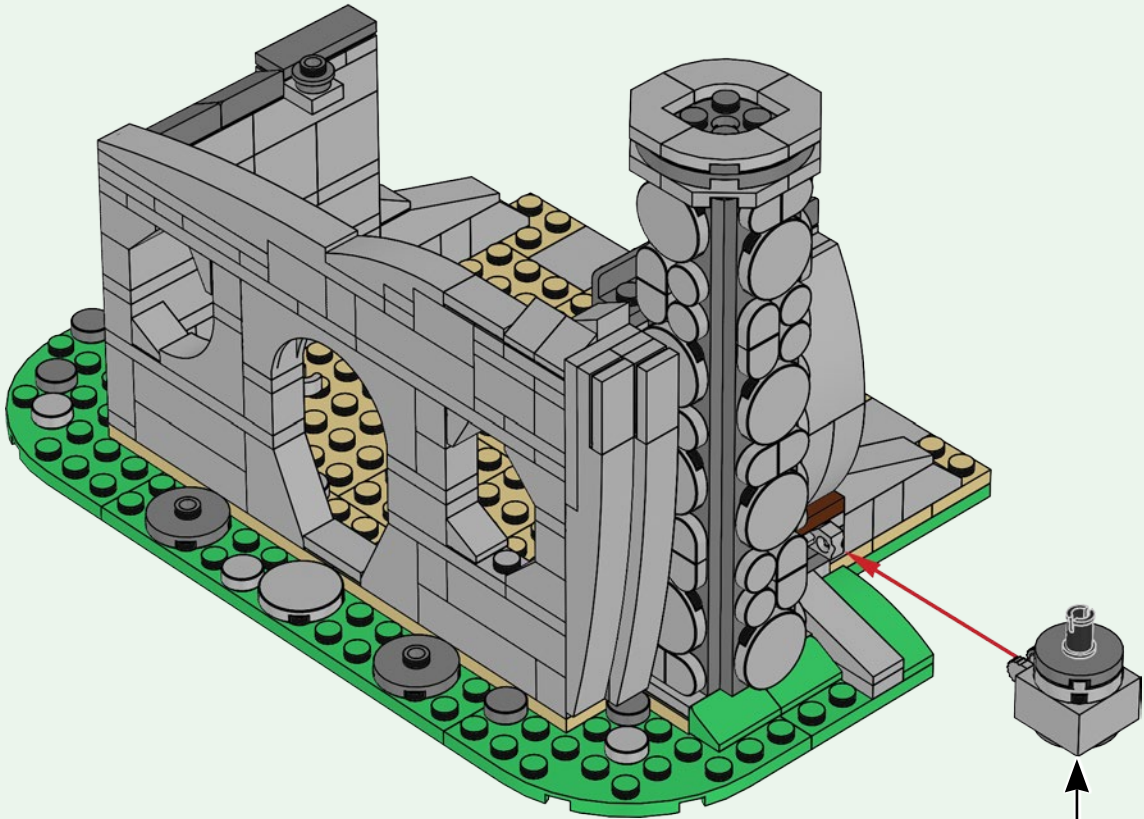

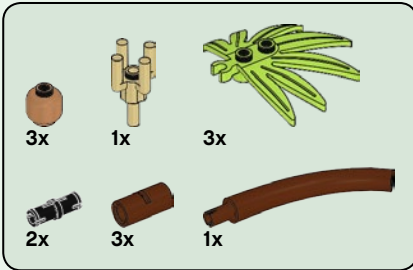

81

1

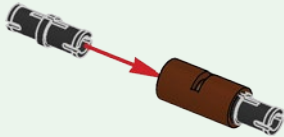

2

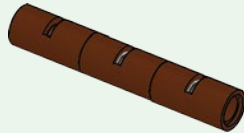

3

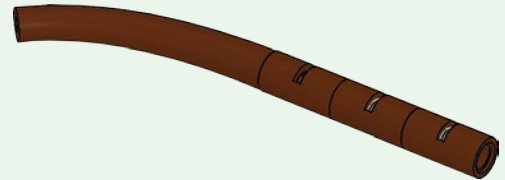

4

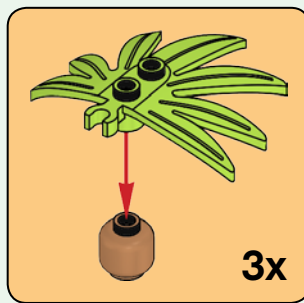
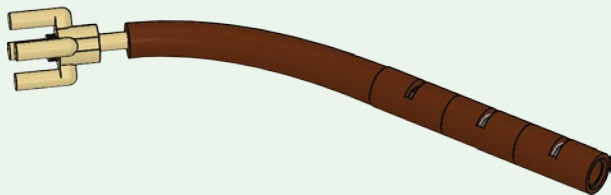

5

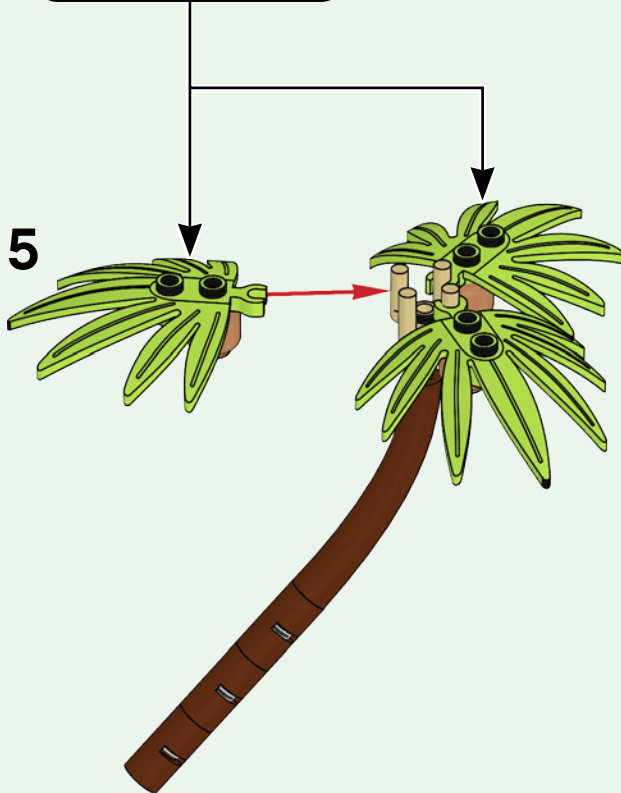

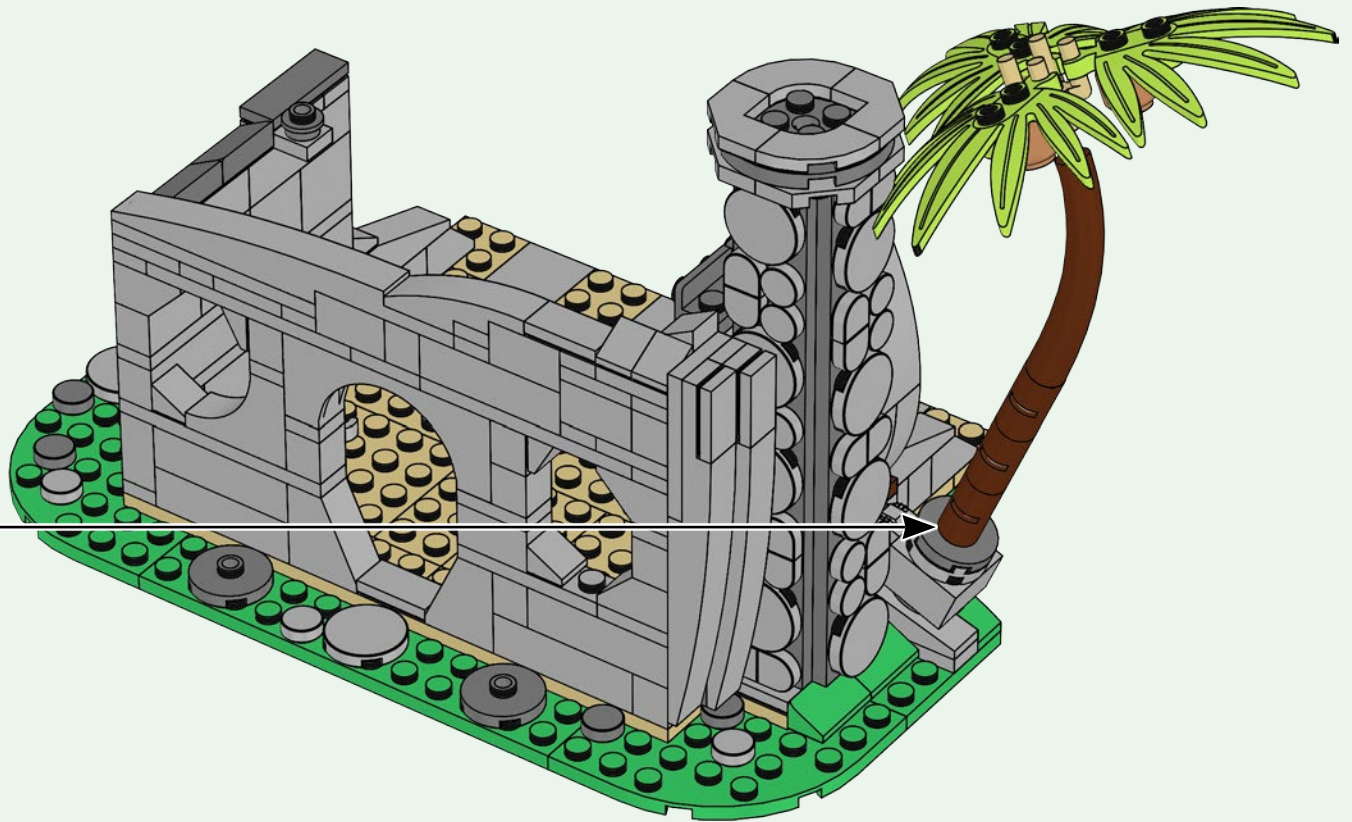

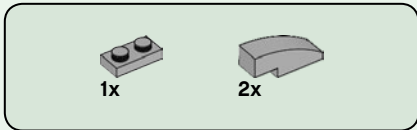

82

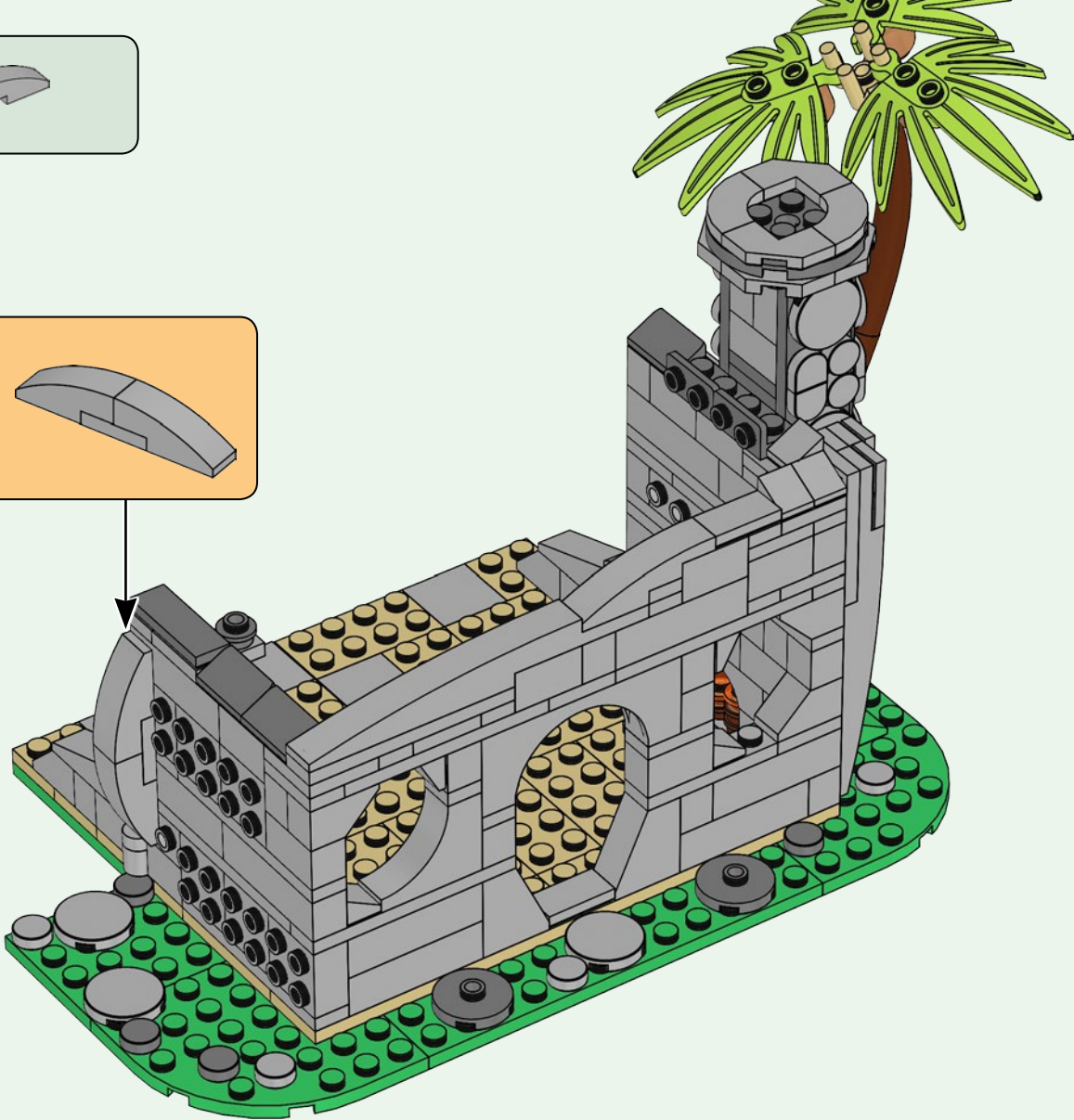
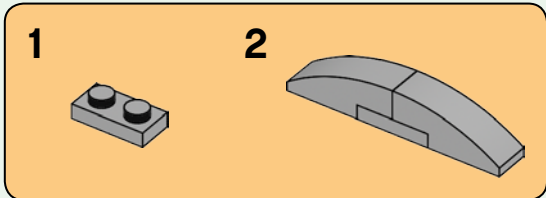

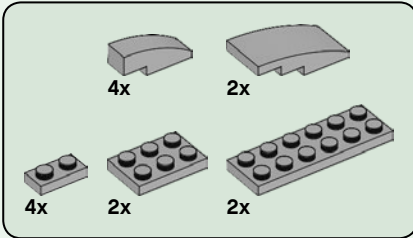
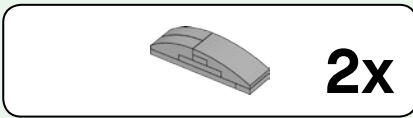

83

1

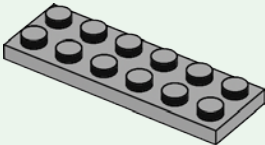

2

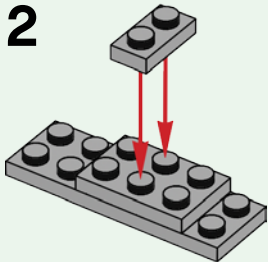

3

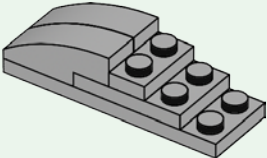

4

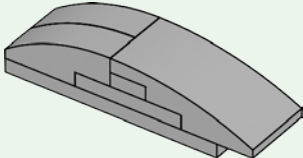

5

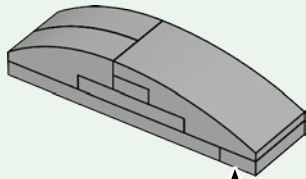

2x

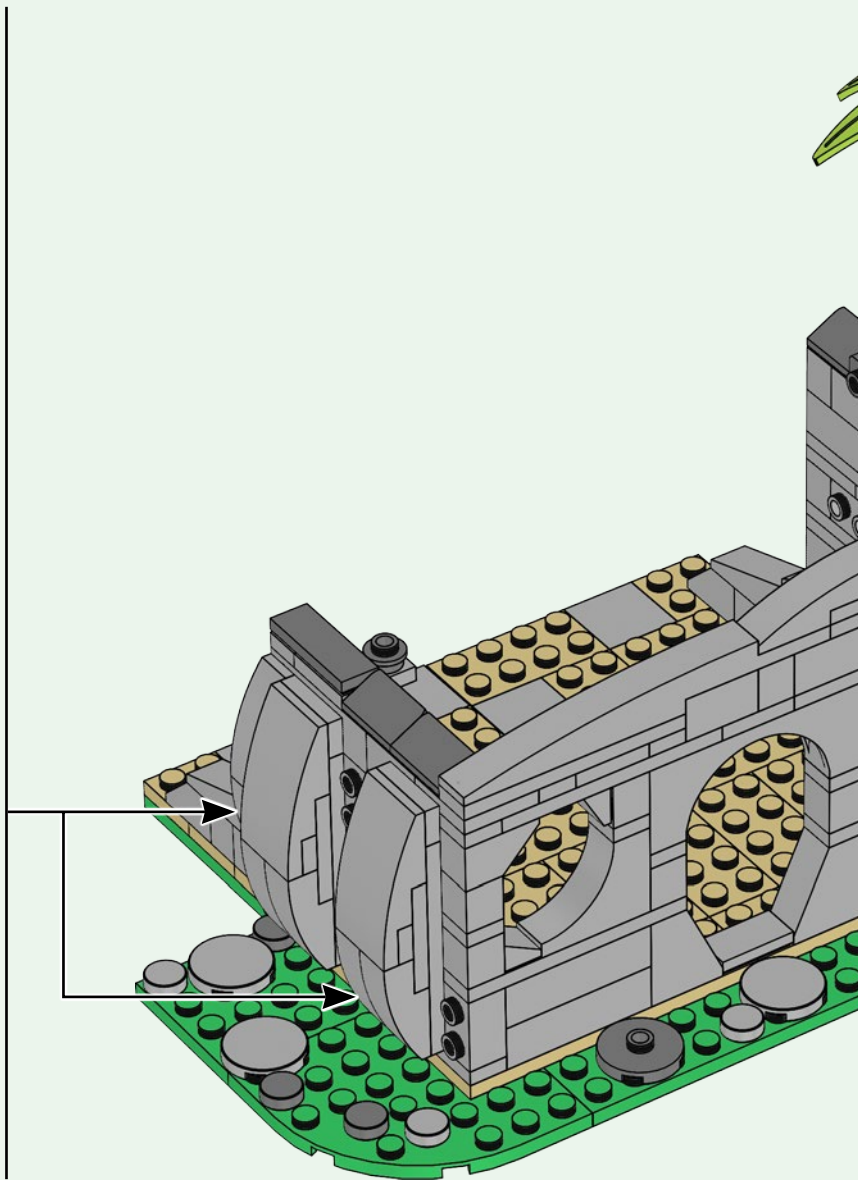
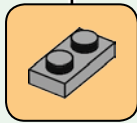

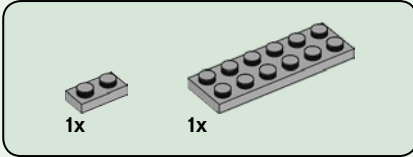
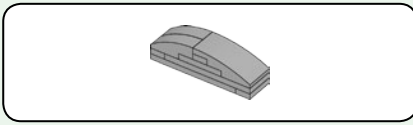

84

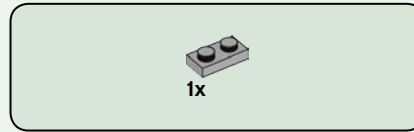
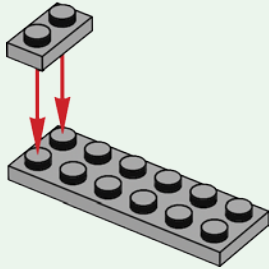

85

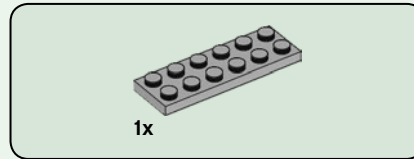
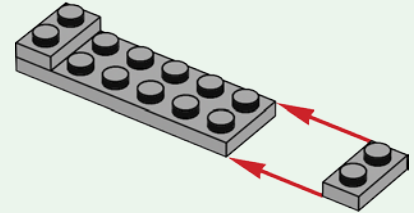

86

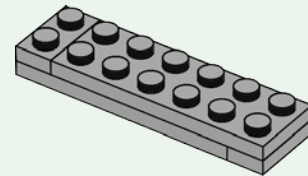

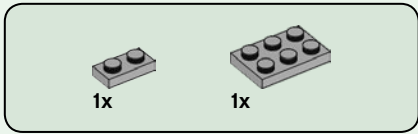

87

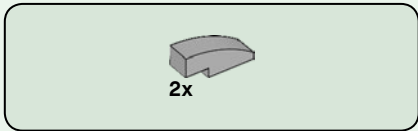
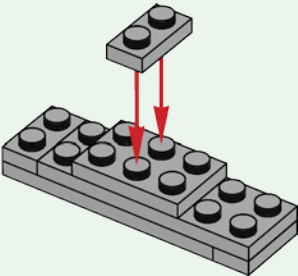

88

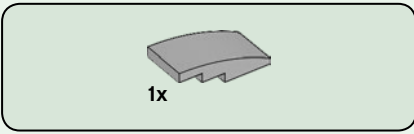
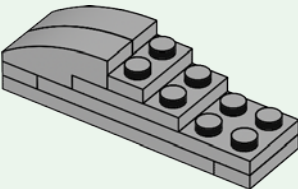

89

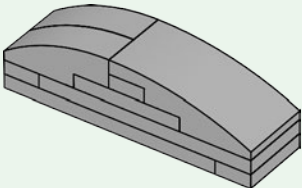

90



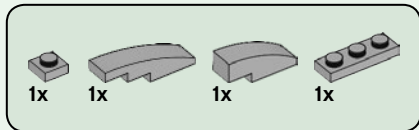

91

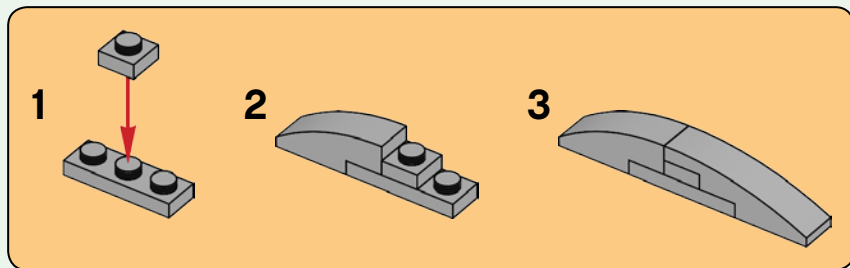

5

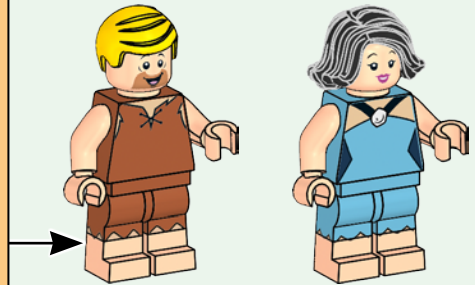
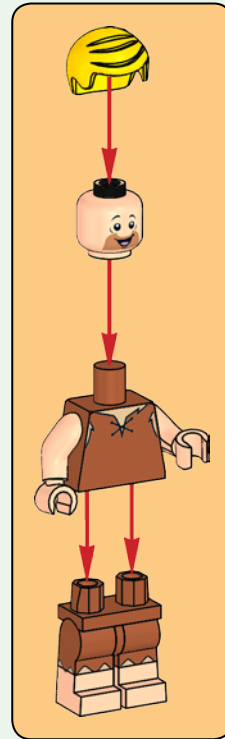

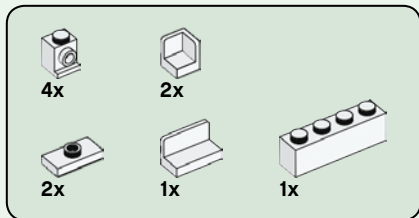

92

1

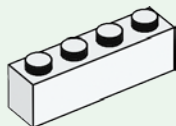

2

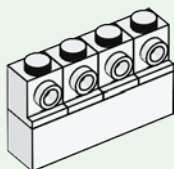

3

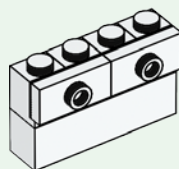

4

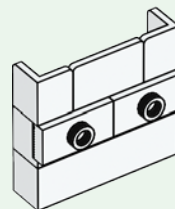

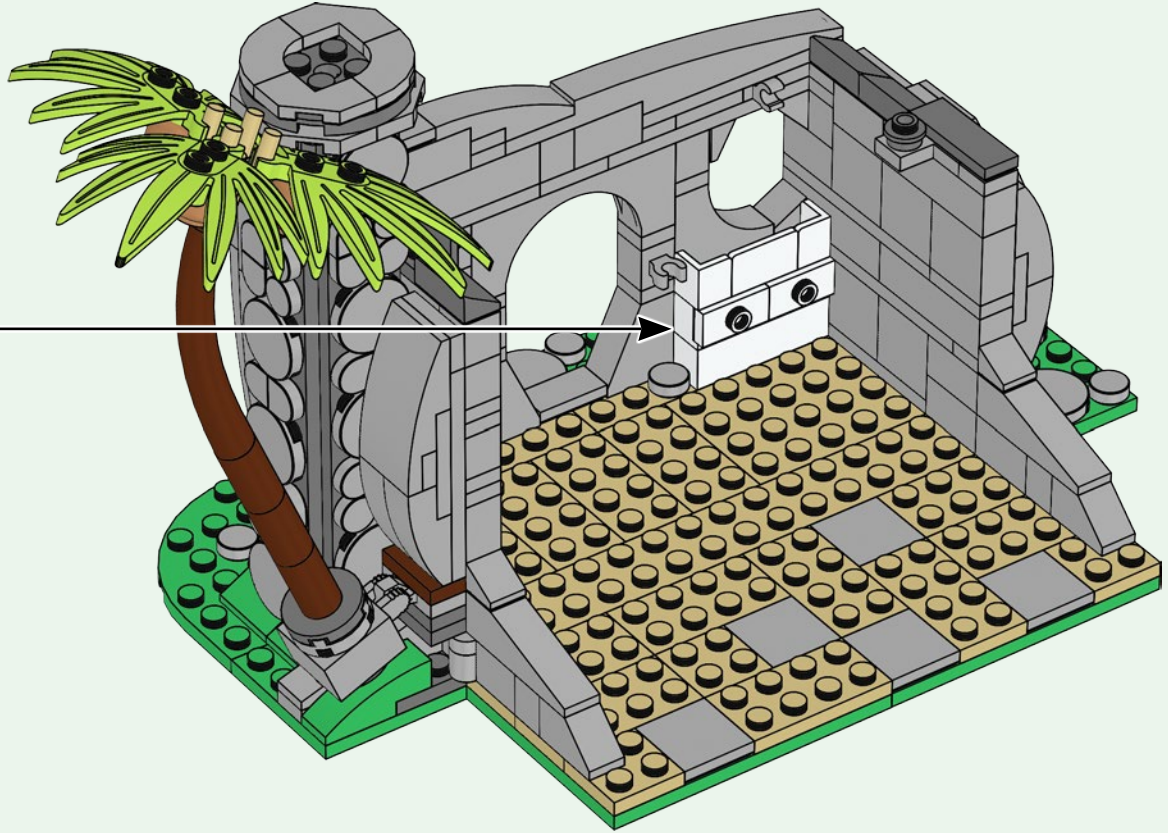



2x



2x



4x

93

1



1

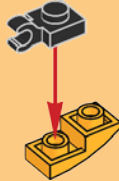

2



2x

2

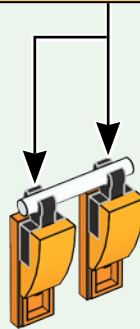

2x

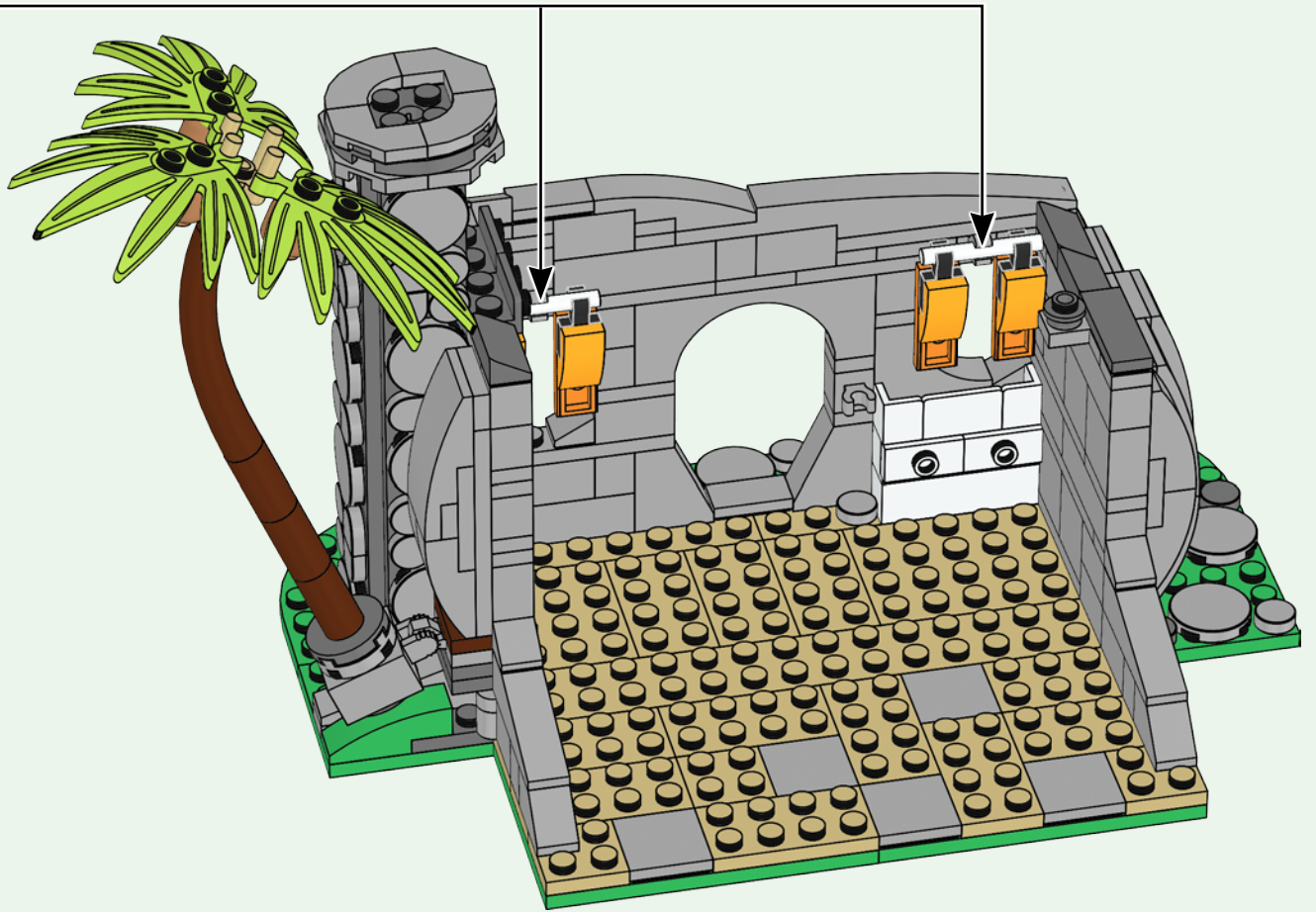

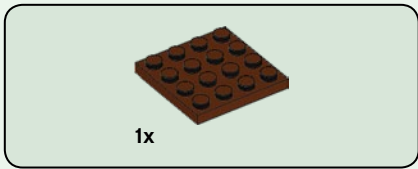

94

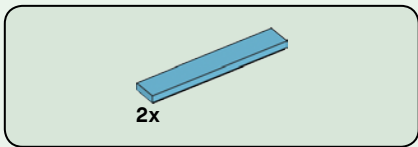

95



96

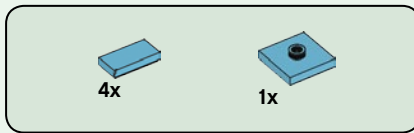
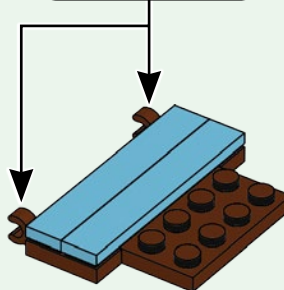

97

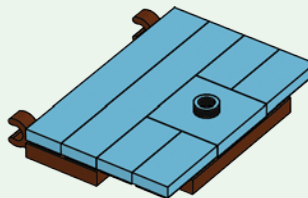

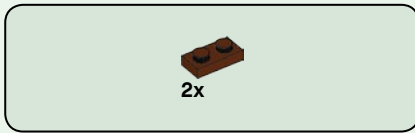

98

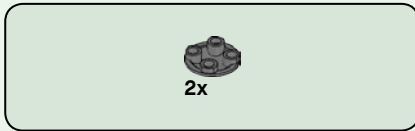
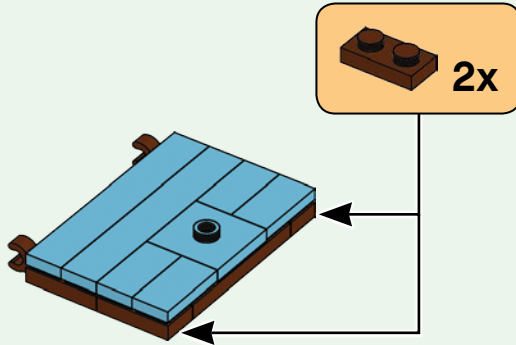

99

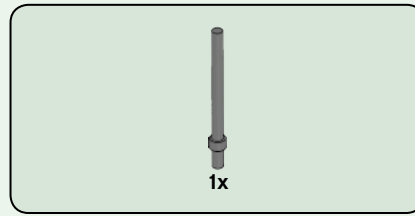
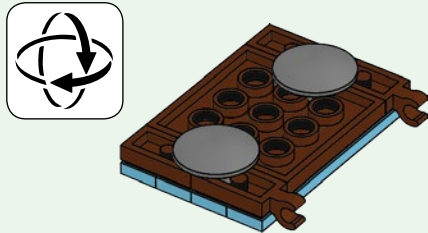

100

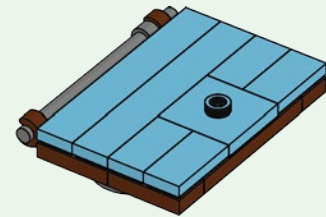
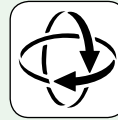

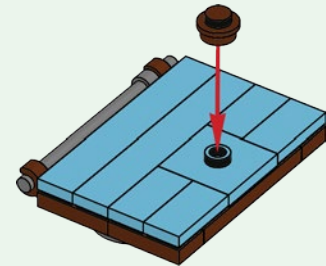

101



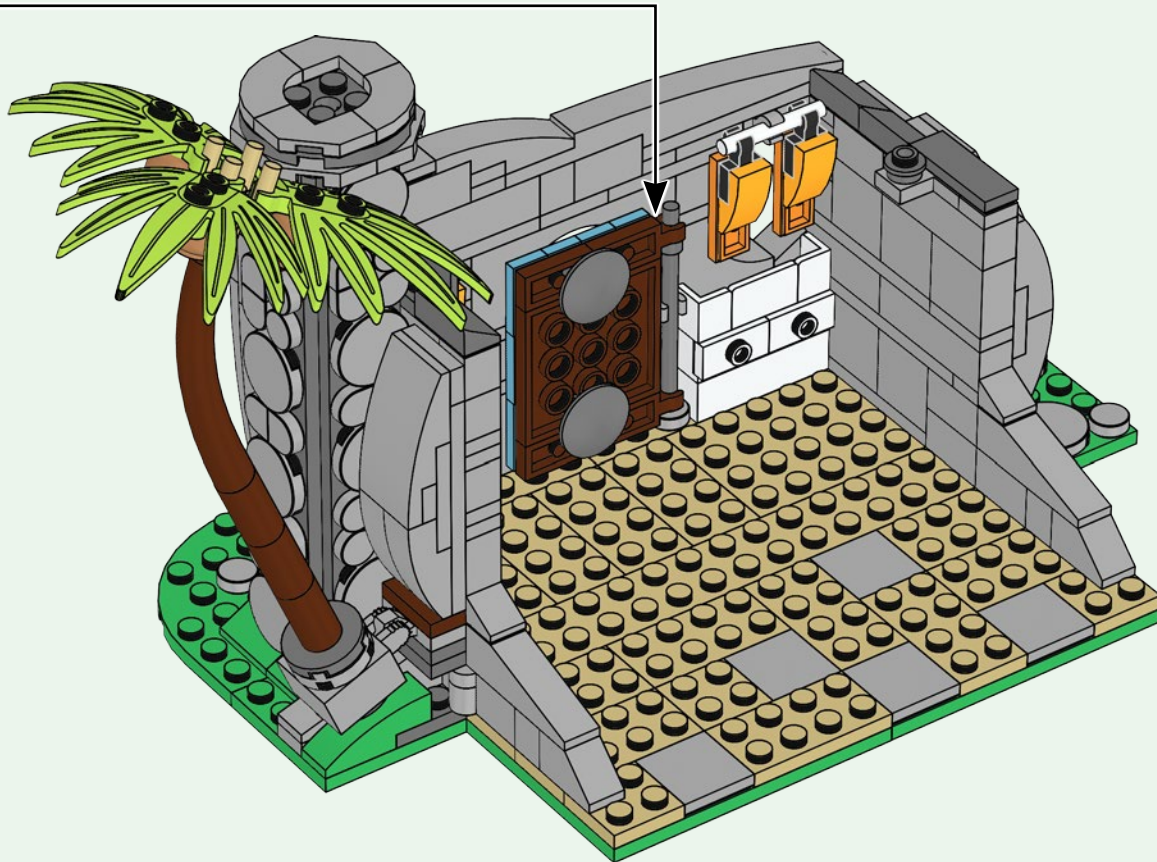

102

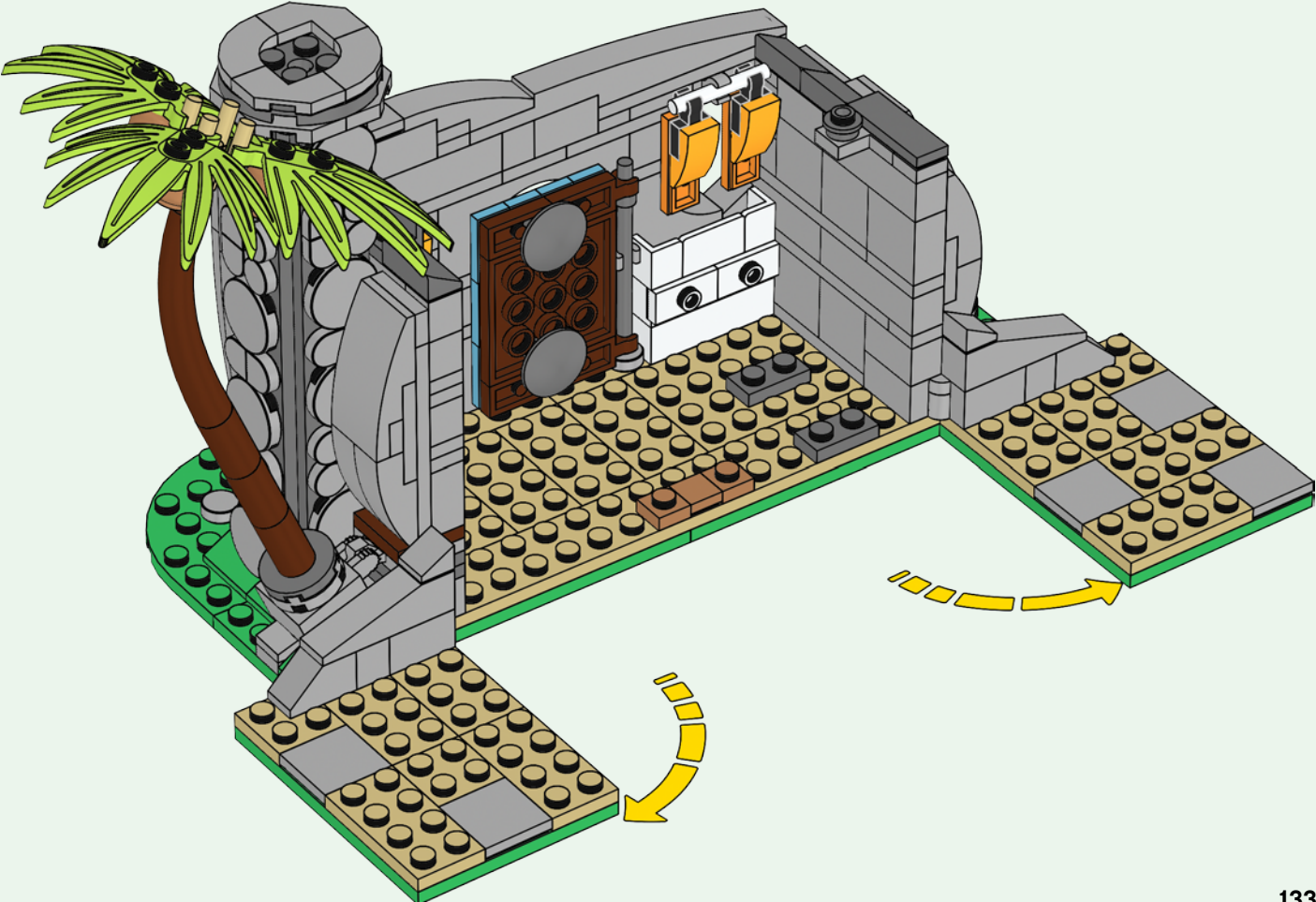

		
1x	2x	2x

103



4x  2x 

104



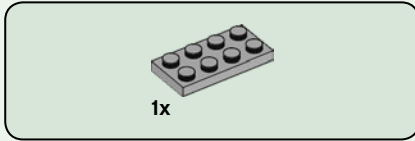
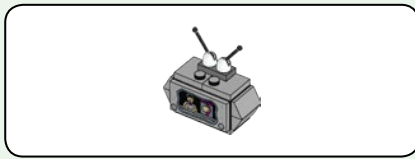

105

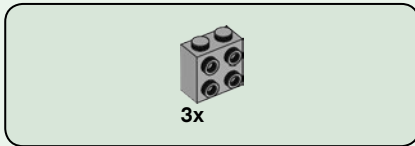
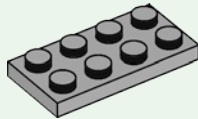

106

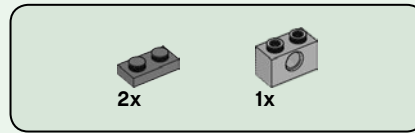
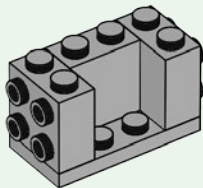

107

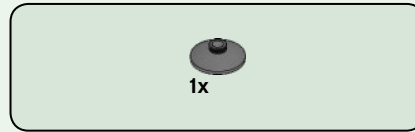
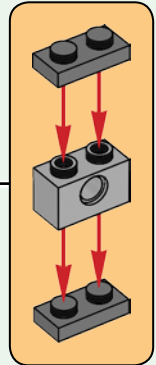
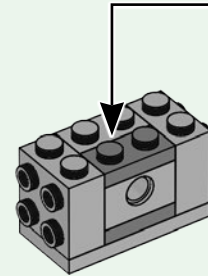

108

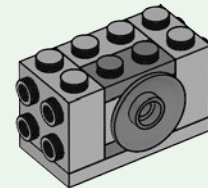



109

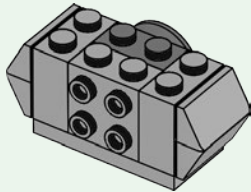

110

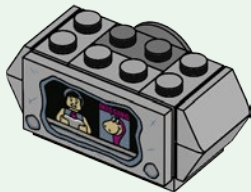

111

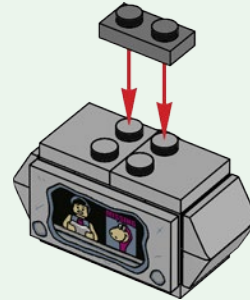

112

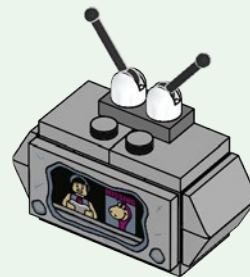

113

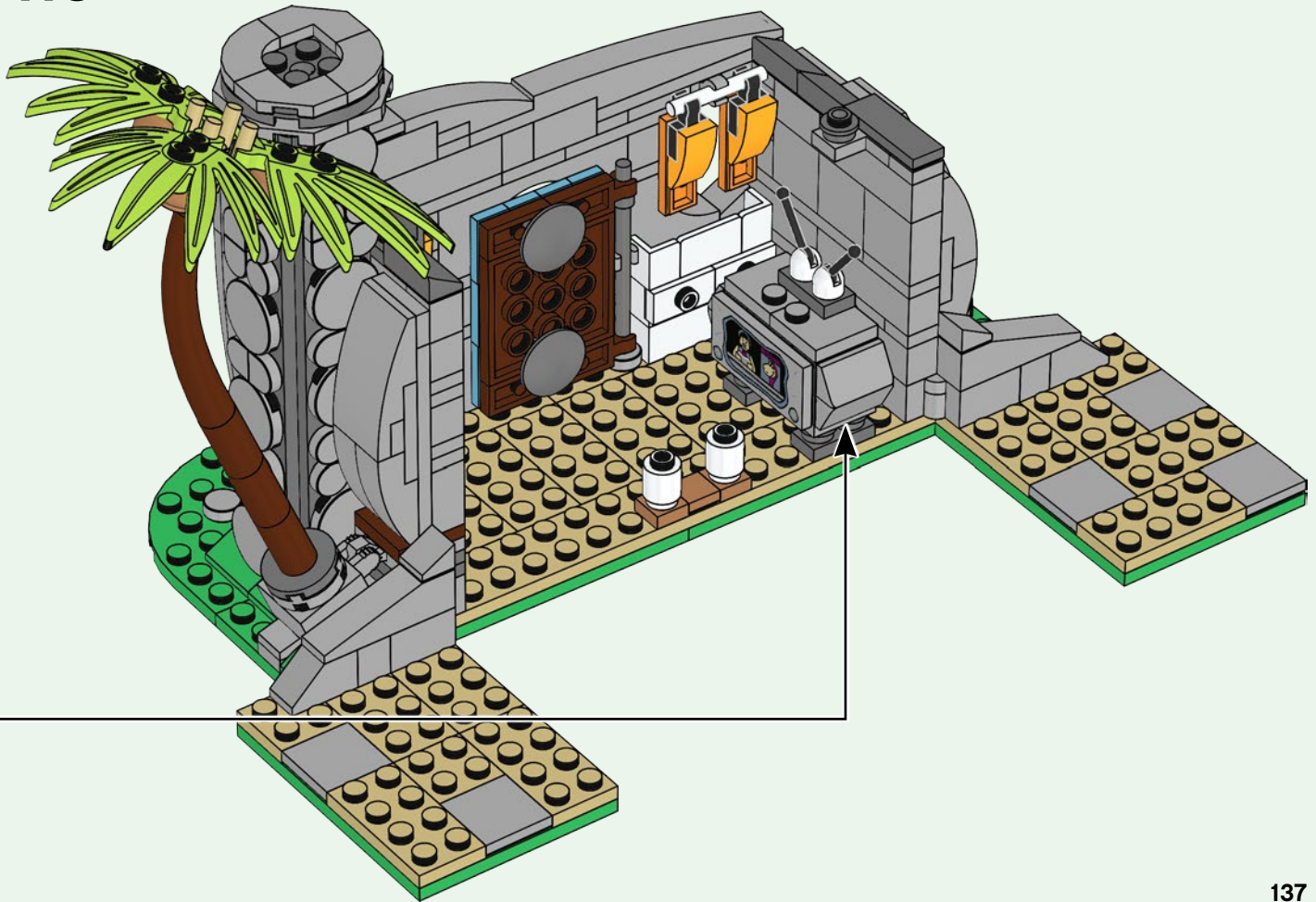

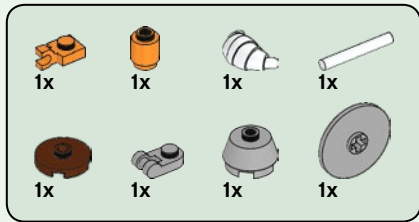

114

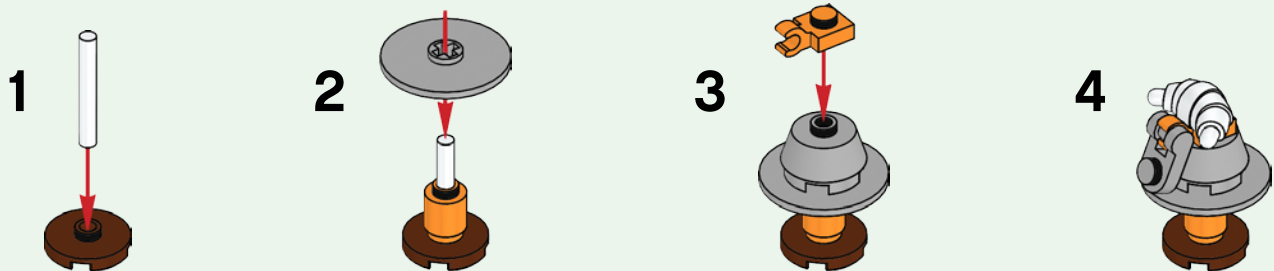





1x

115

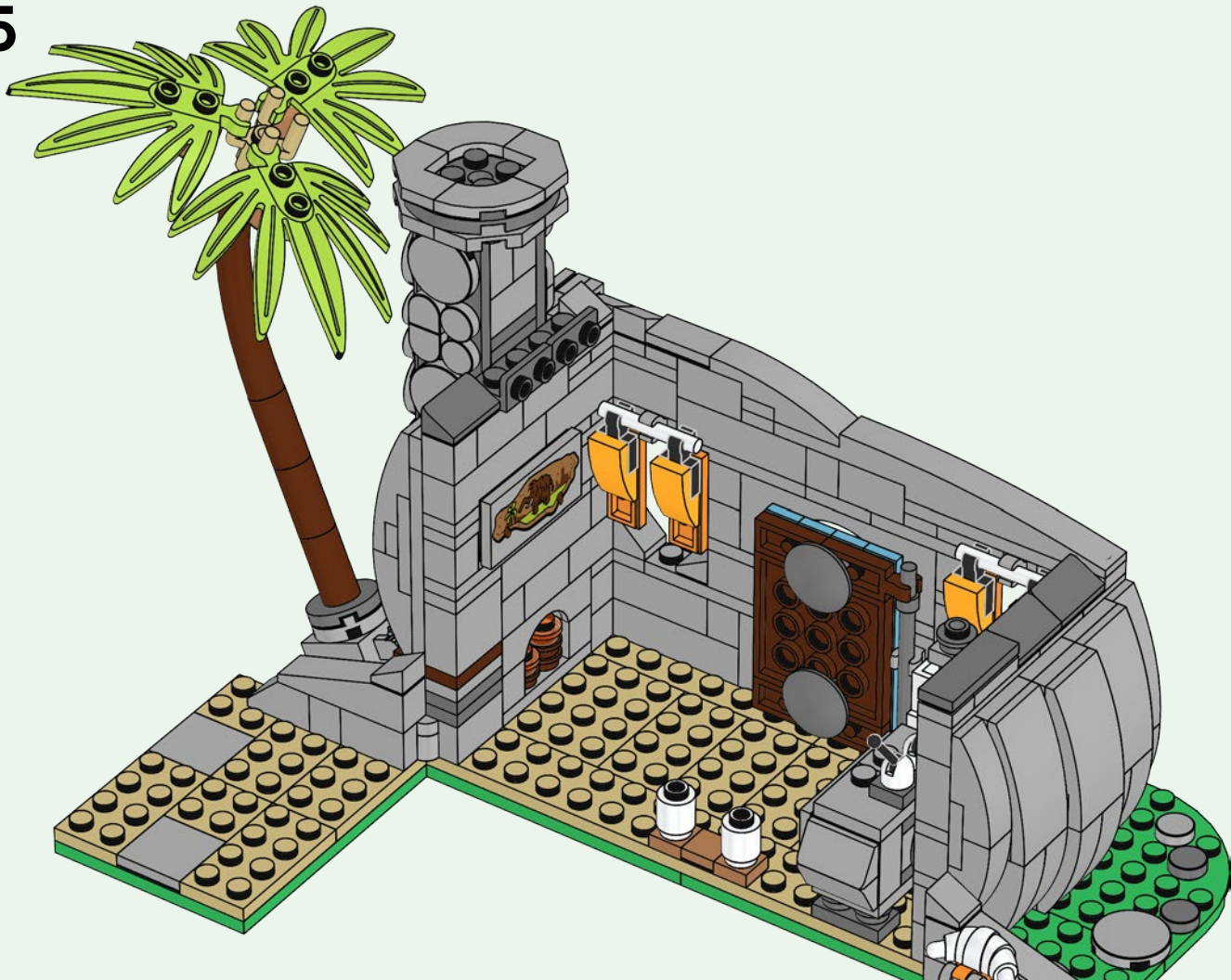

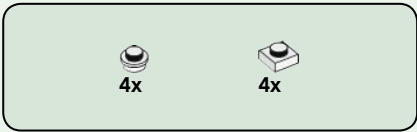

116

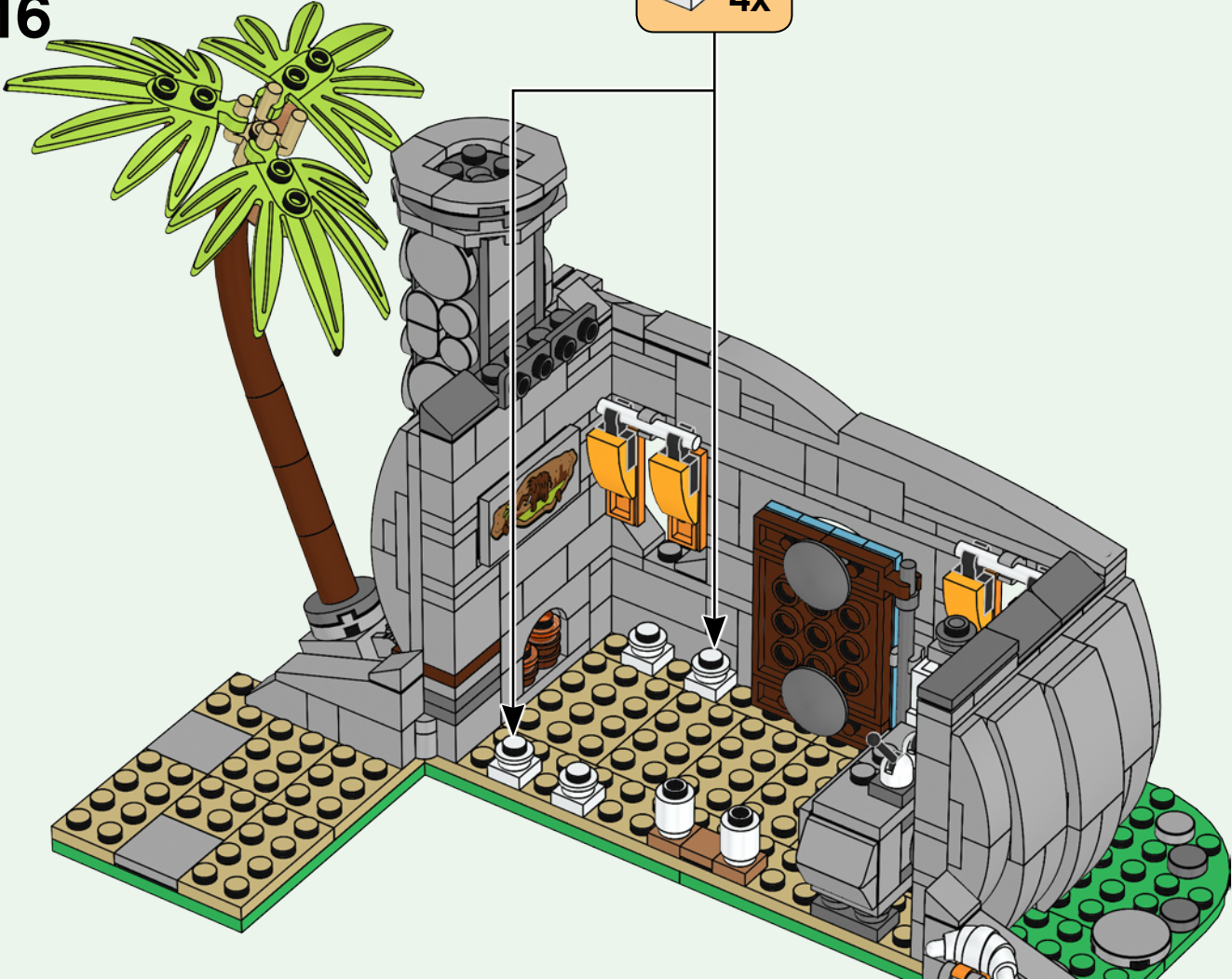
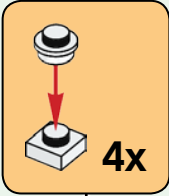

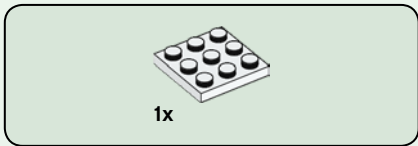
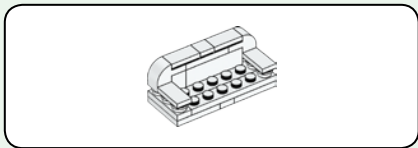

117

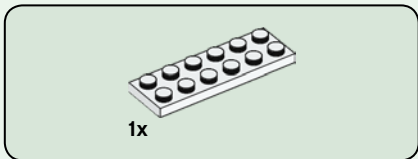
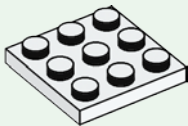

118

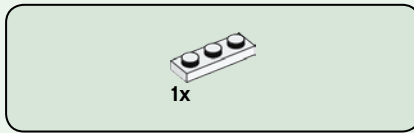
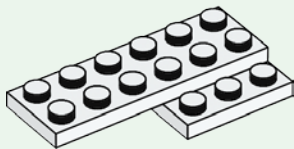

119

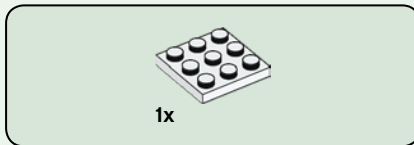
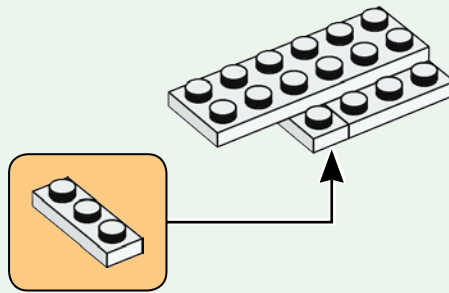

120

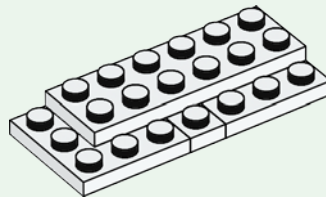

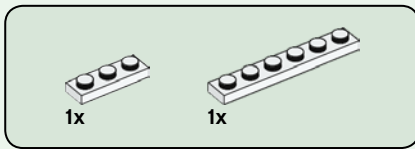

121

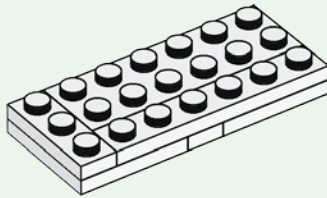

122

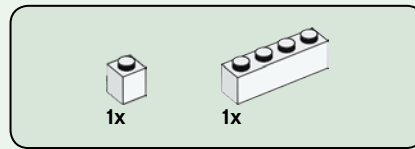
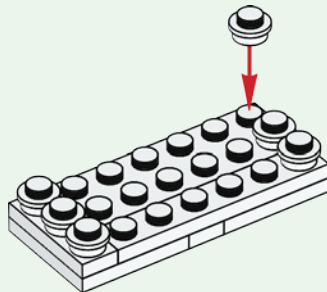

123

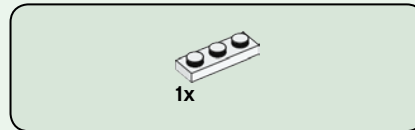
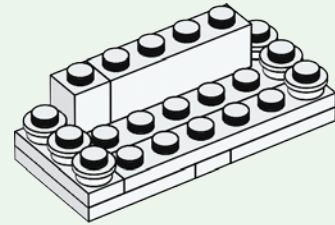

124

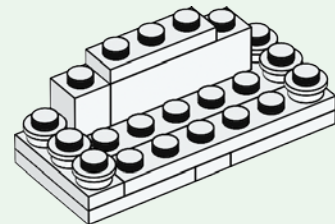

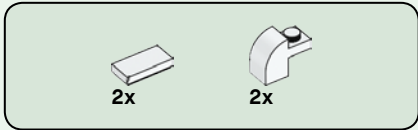

125

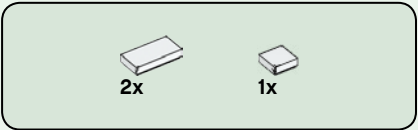
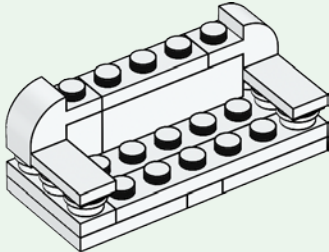

126

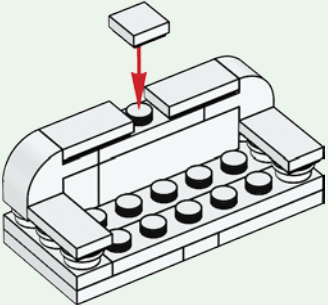



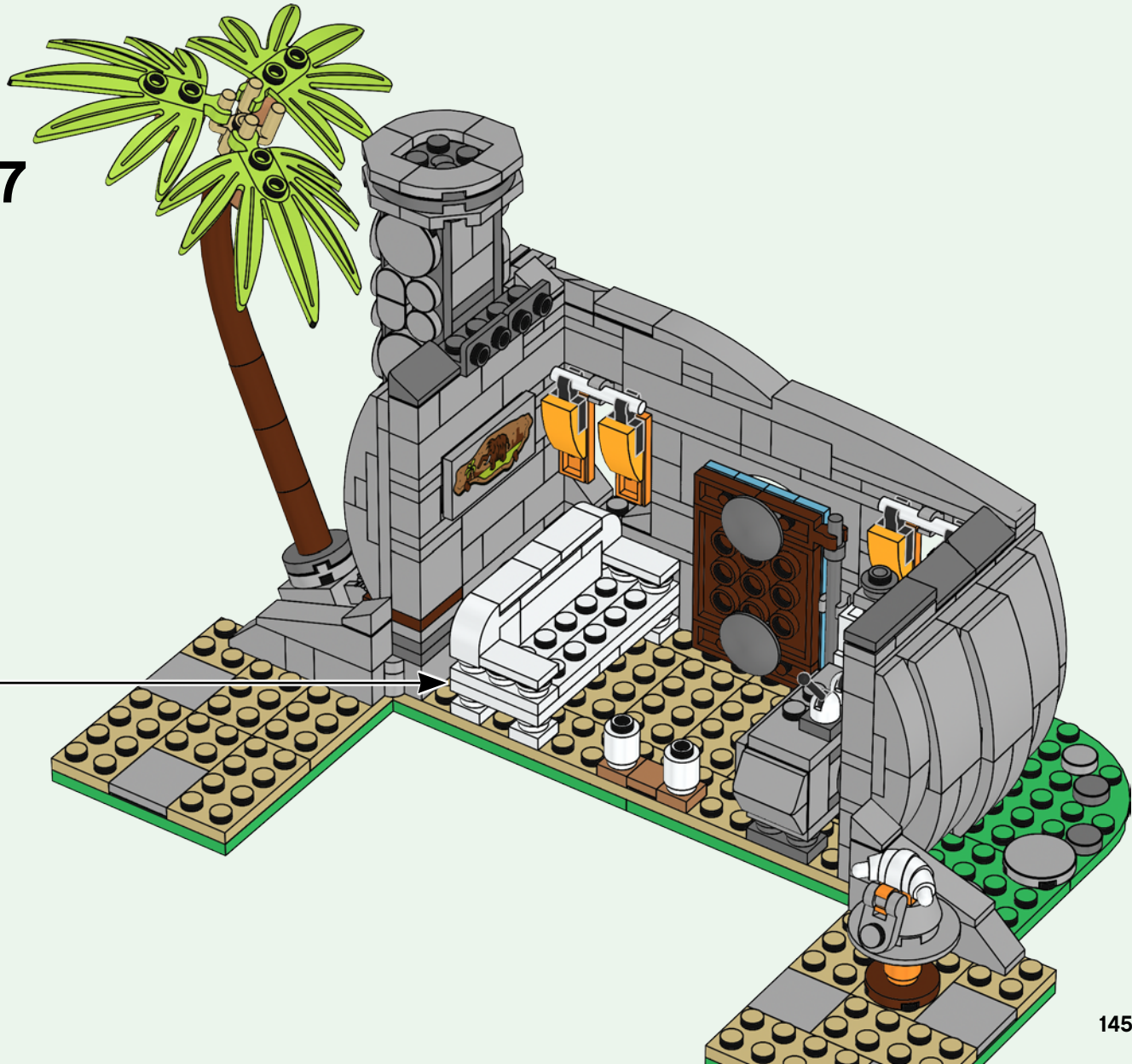

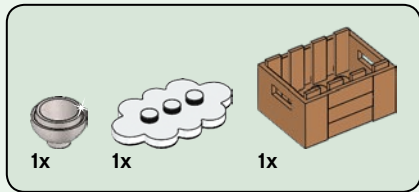
127



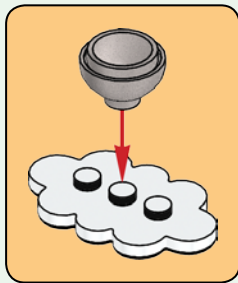

128



			
3x	1x	3x	3x

129

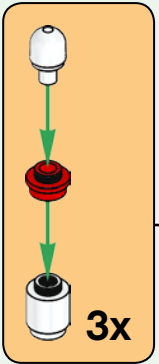
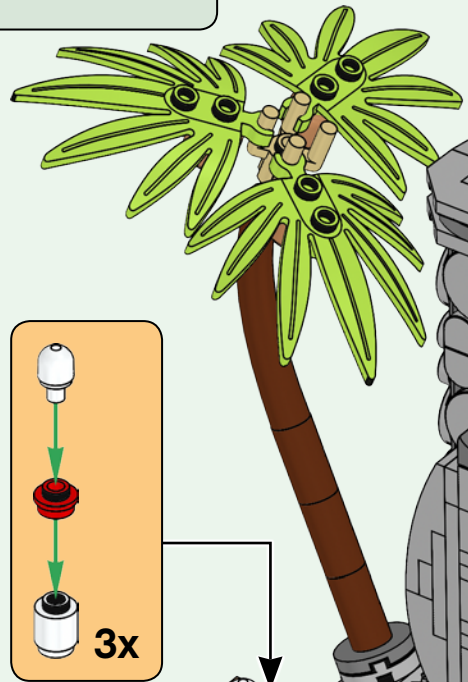

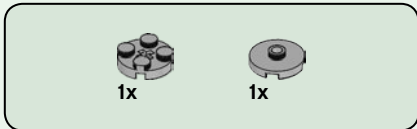

130

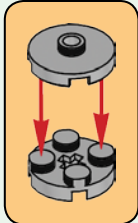

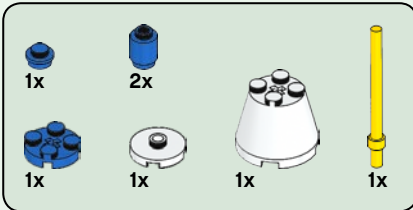

131

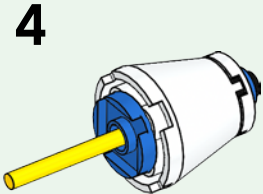
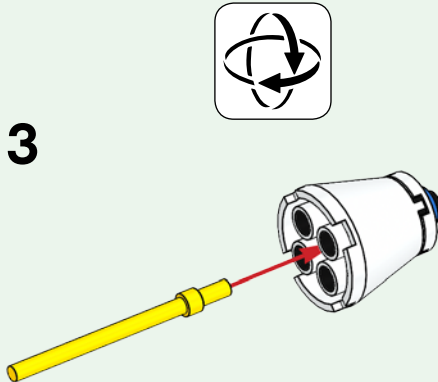
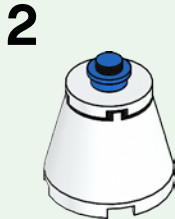
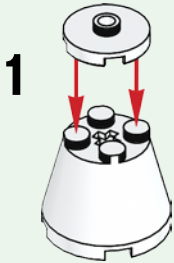

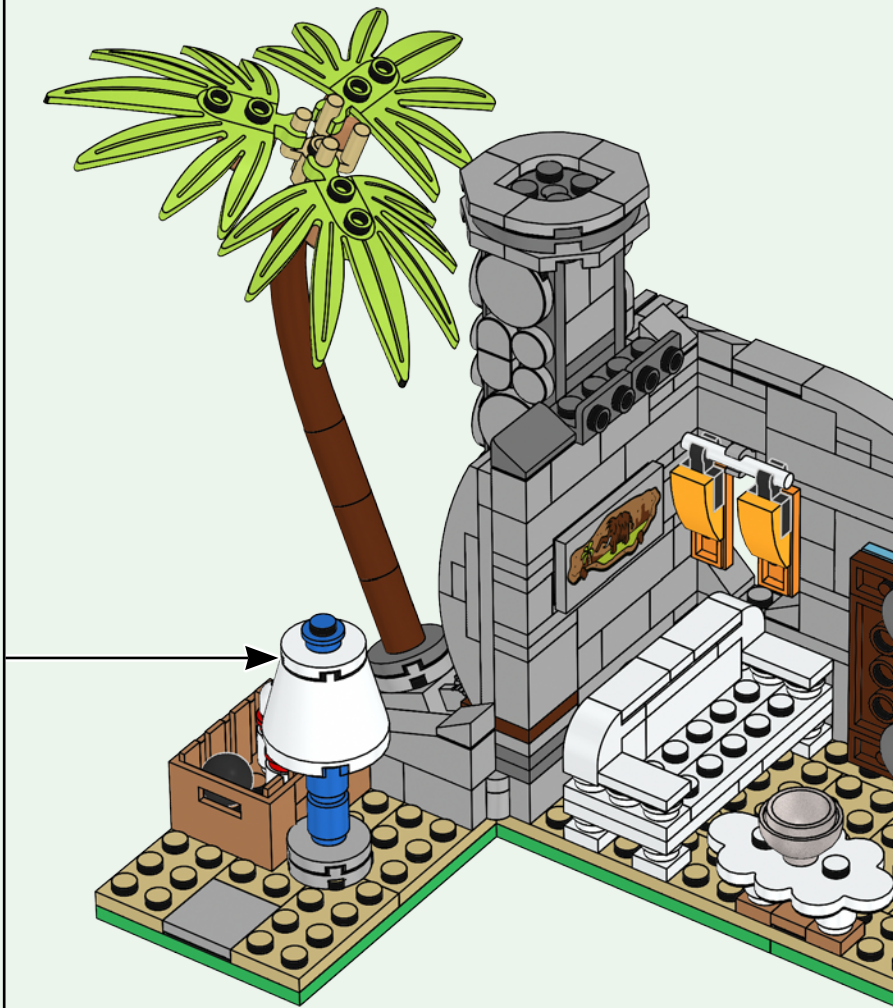
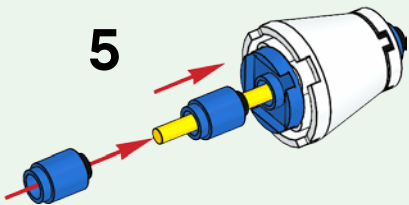



1x



1x

132



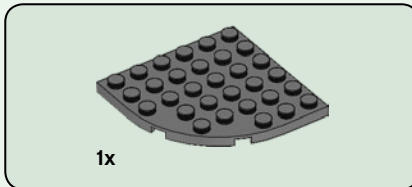
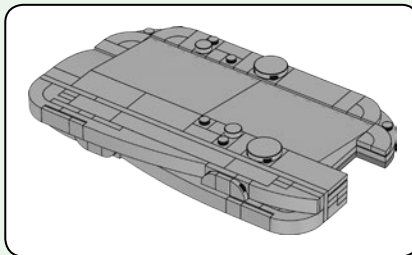
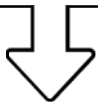

133

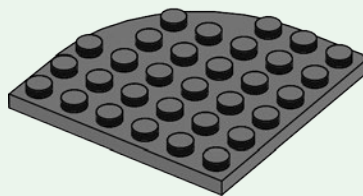

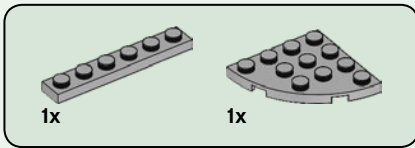

134

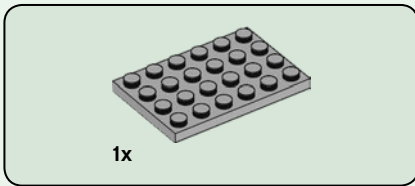
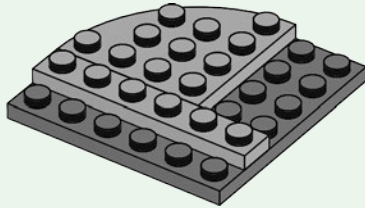

135

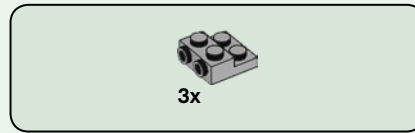
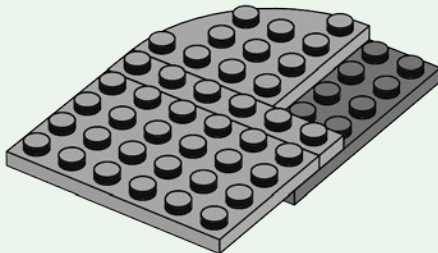

136

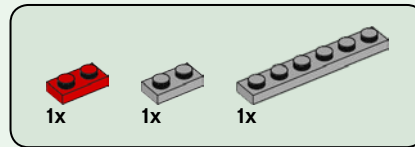
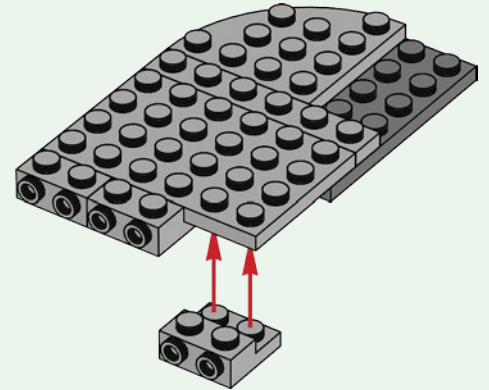

137

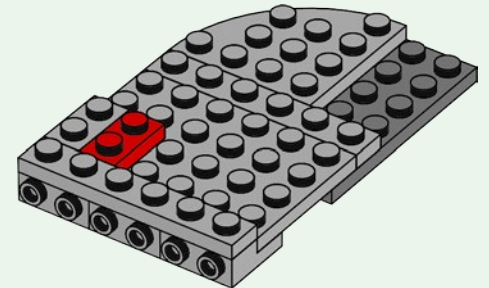

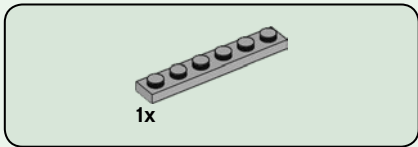
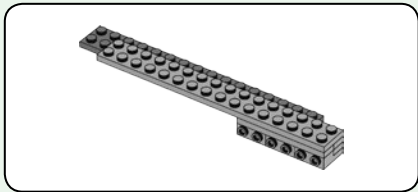

1x

138

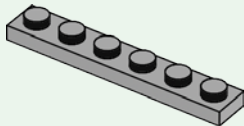

3x

139

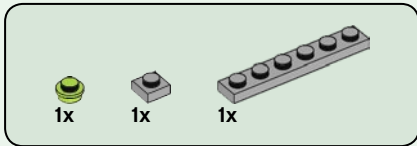
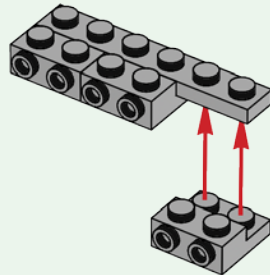

1x

1x

1x

140

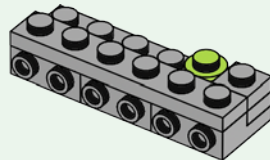

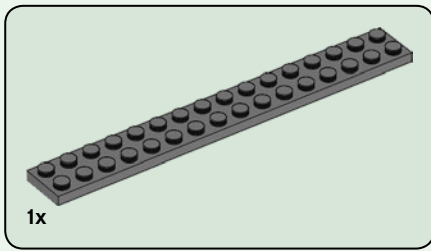

141

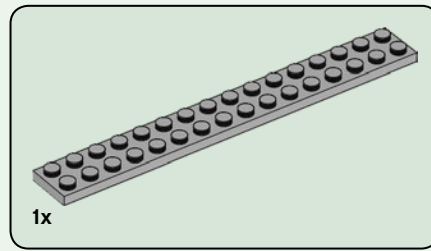
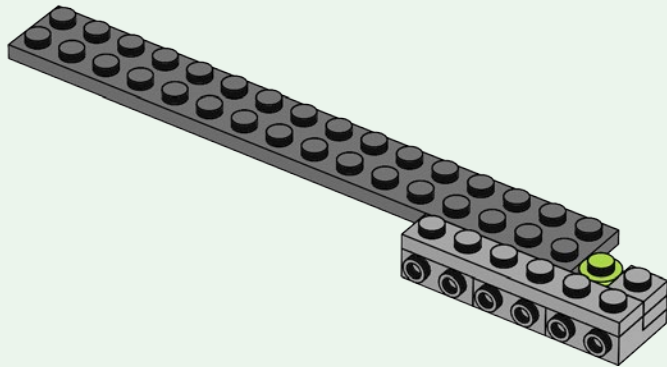

142

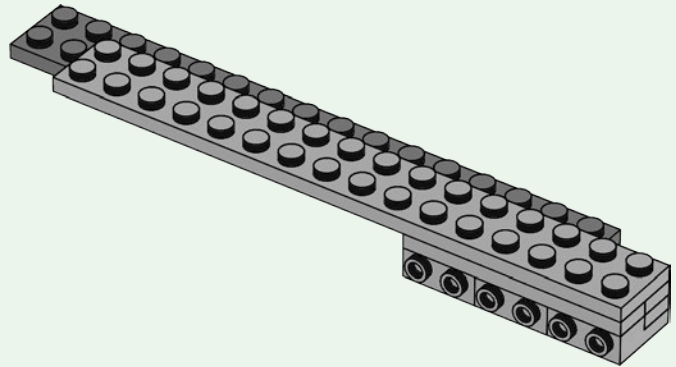

143

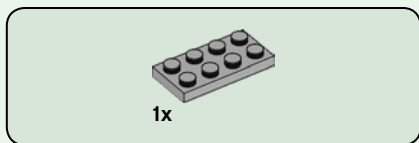
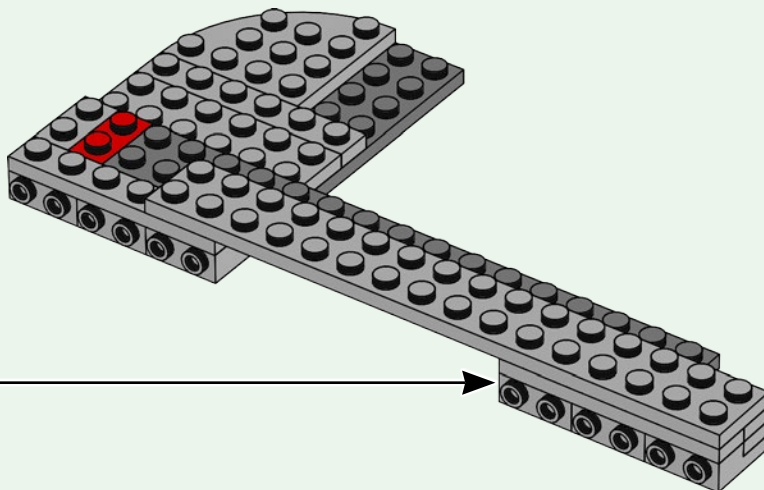

144

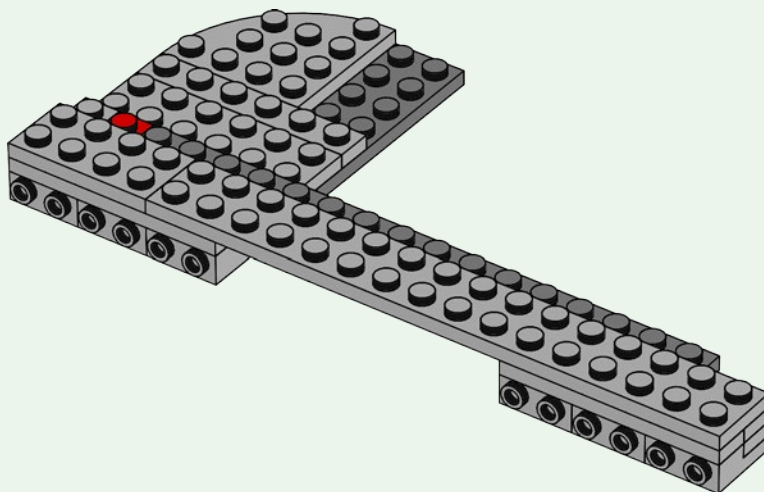

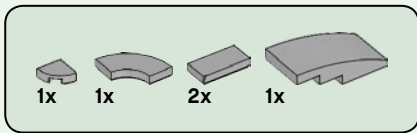

145

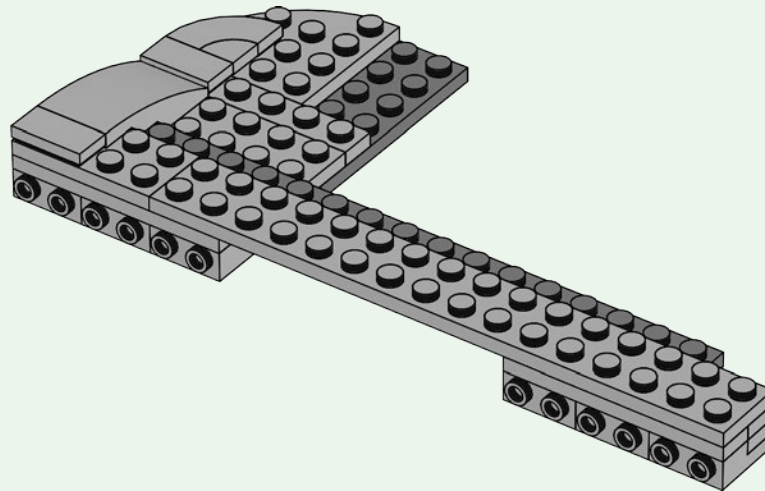

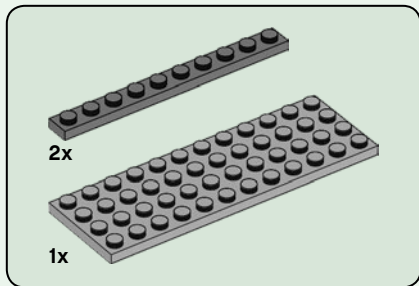

146

1

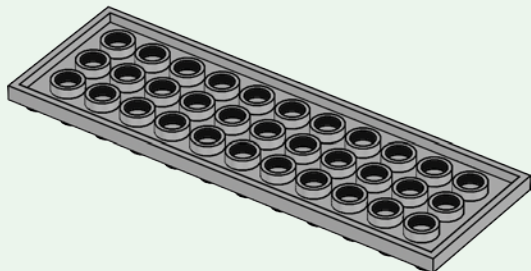

2

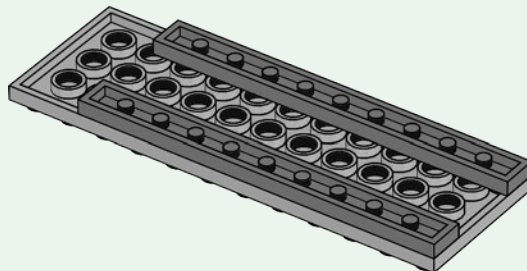

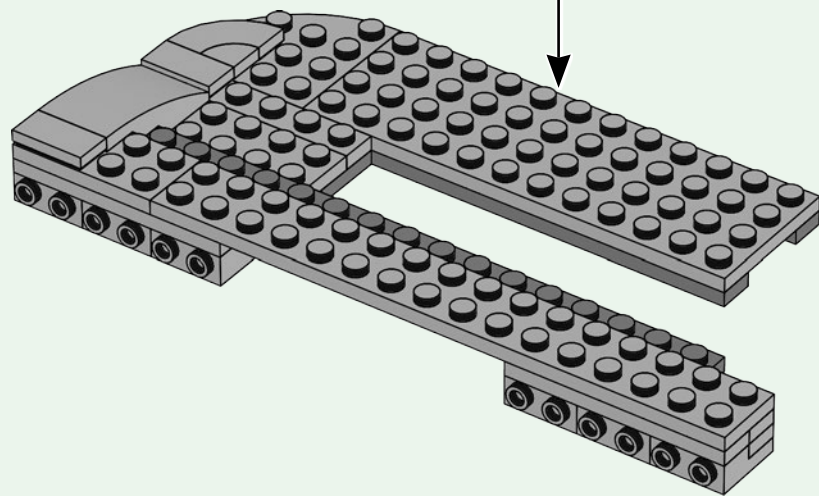

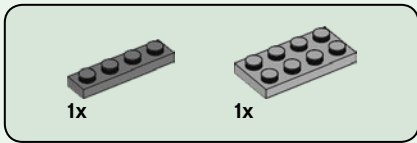

147

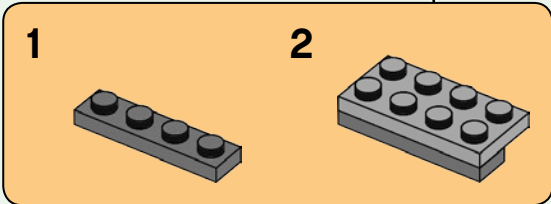
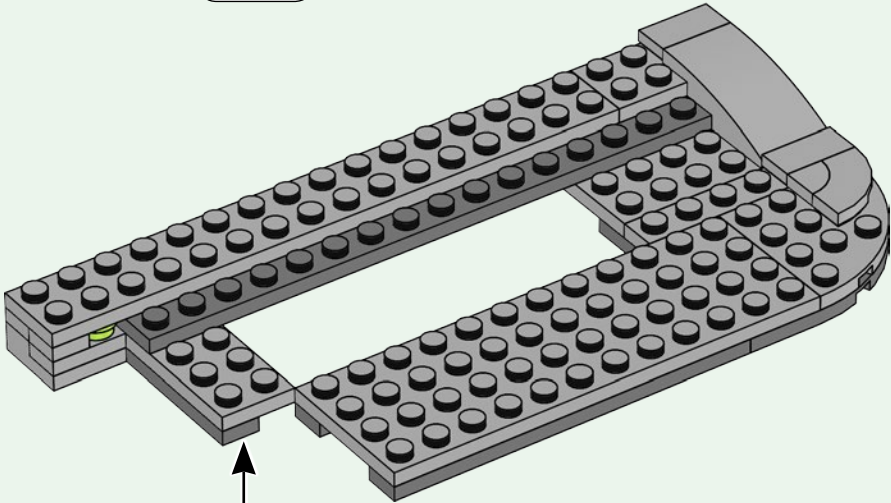

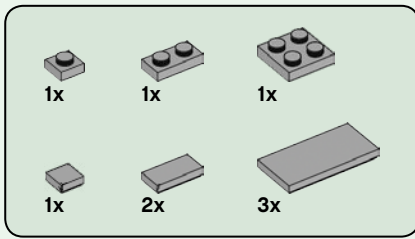

148

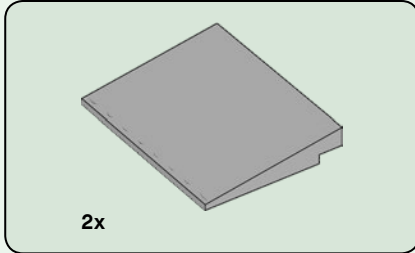
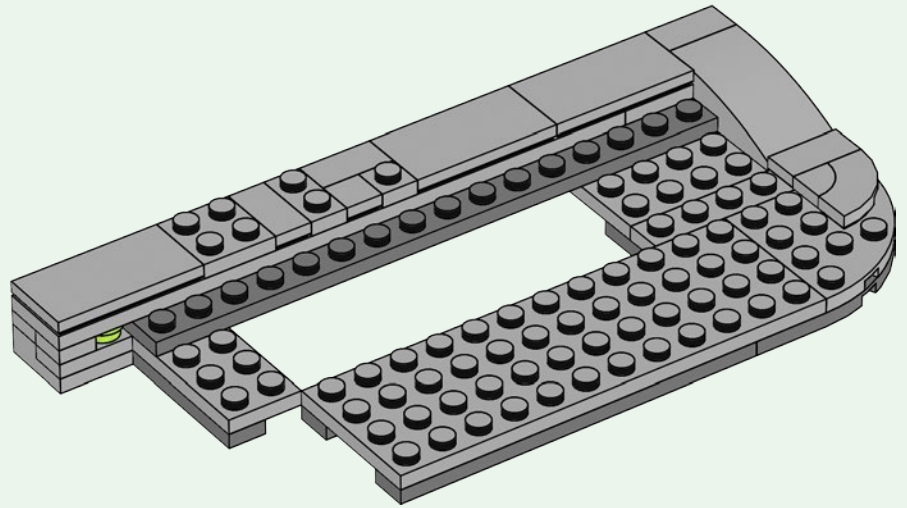

149

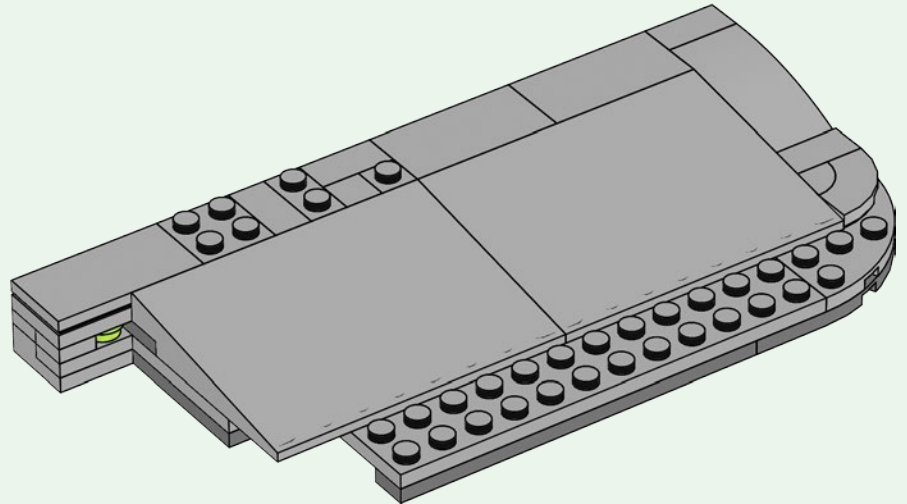

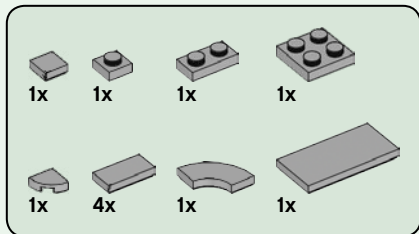

150

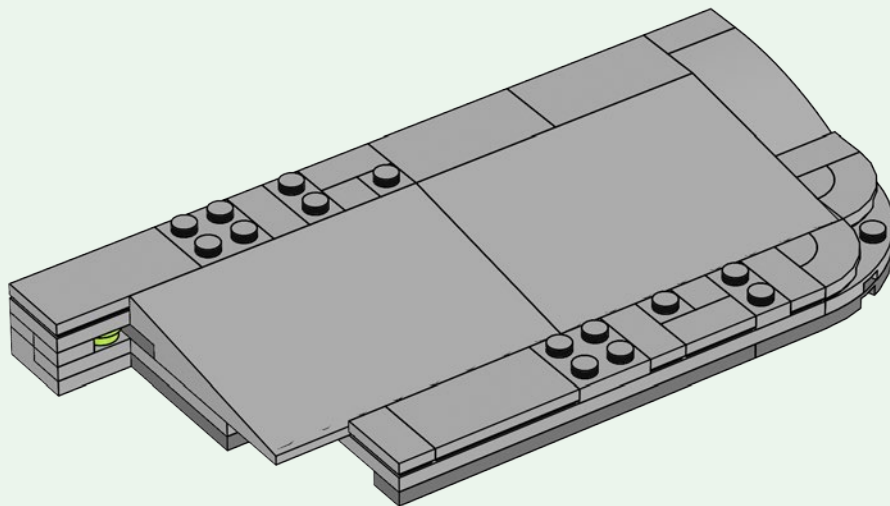

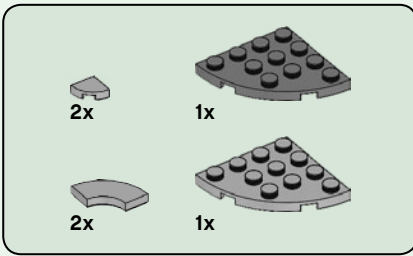

151

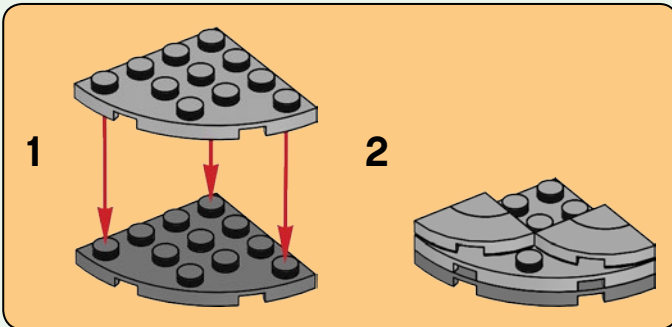
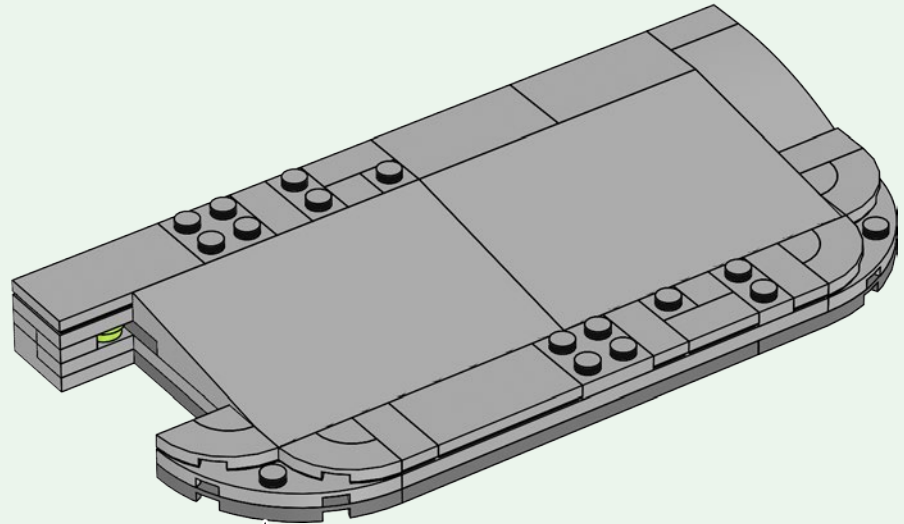

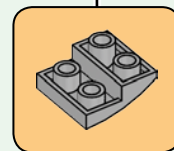
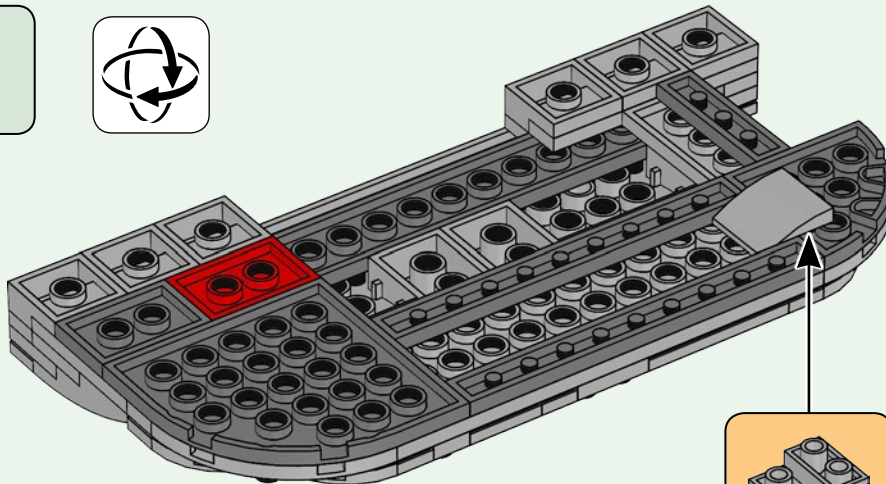
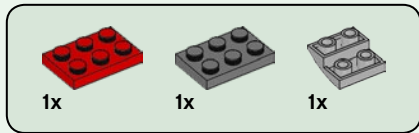

152

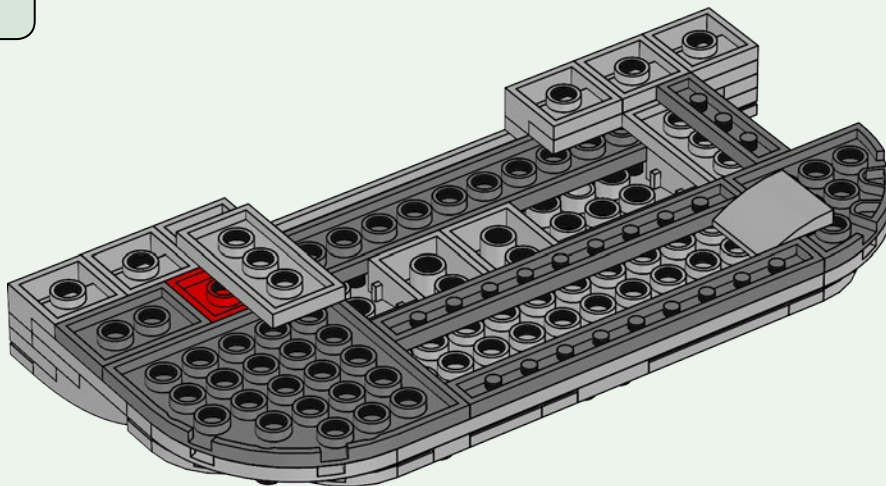
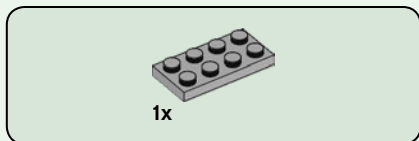

153



154

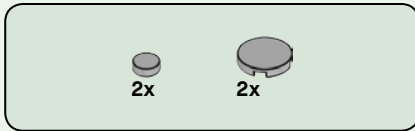
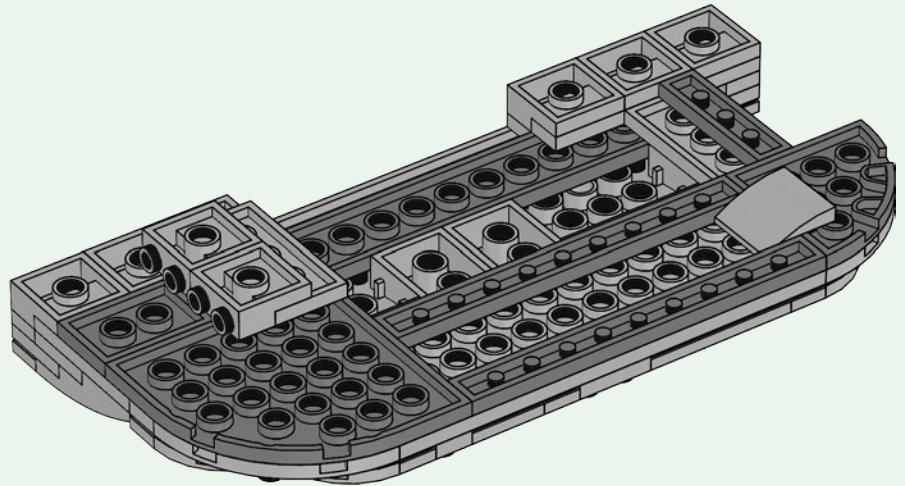

155

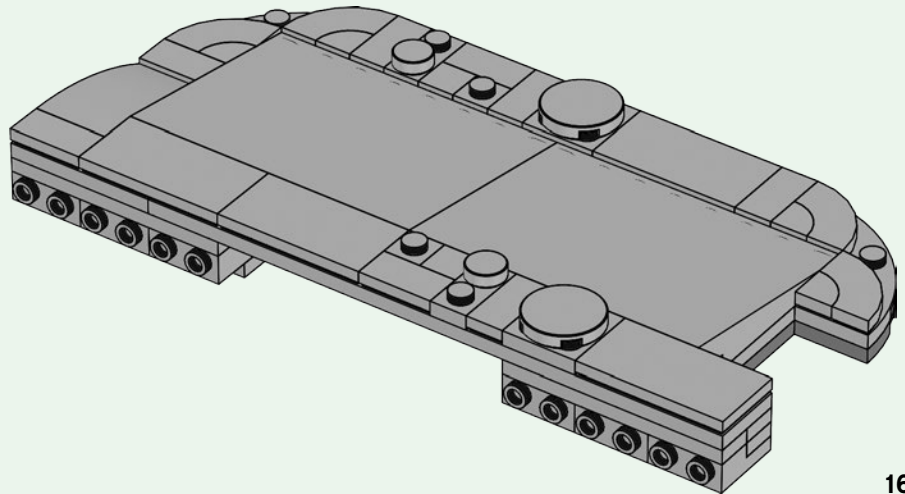
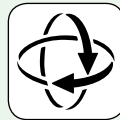

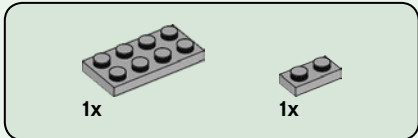
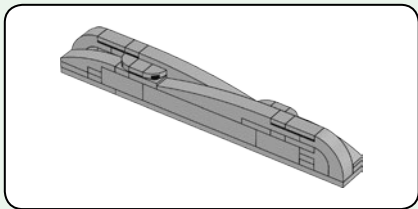

156

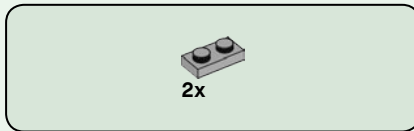
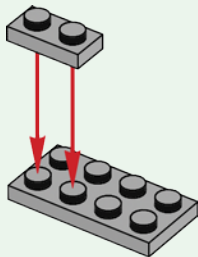

157

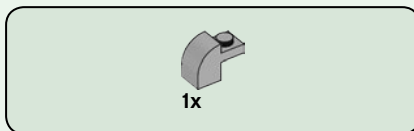
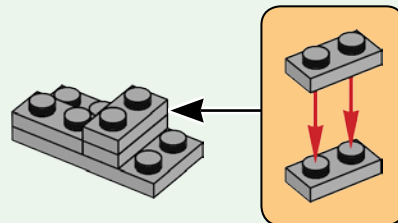

158

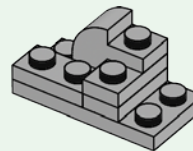

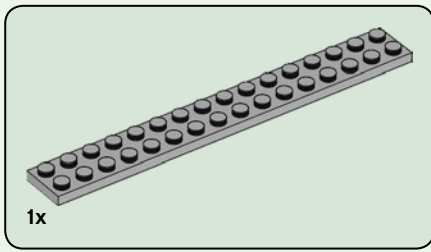

159

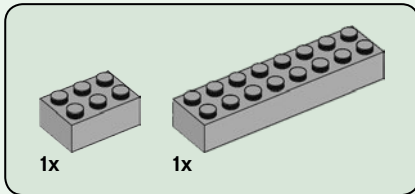
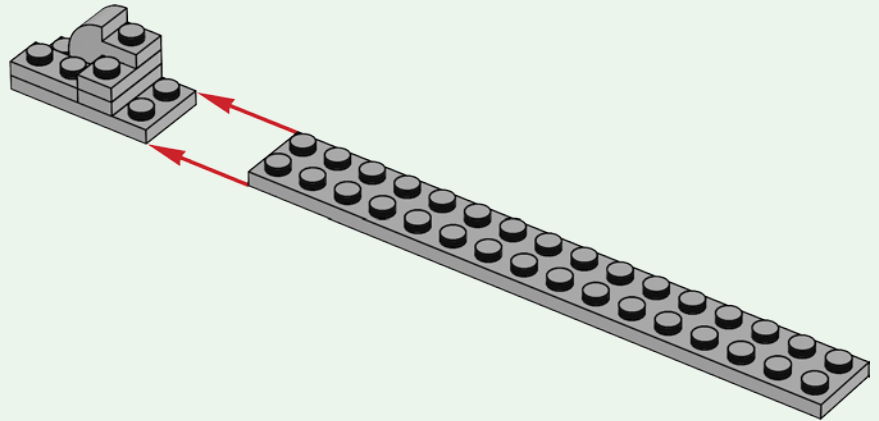

160

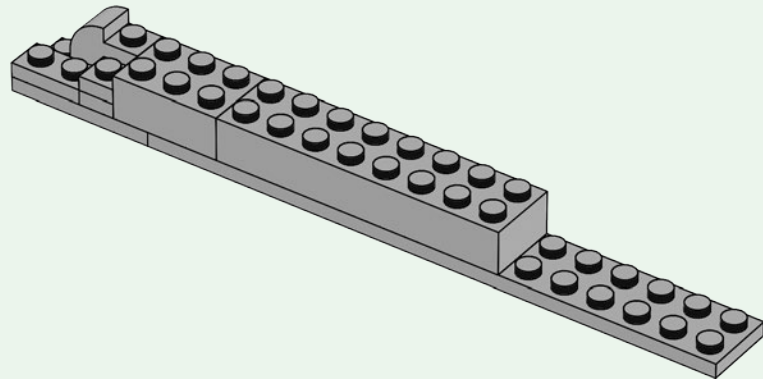

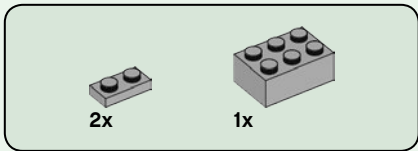

161

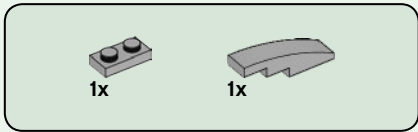
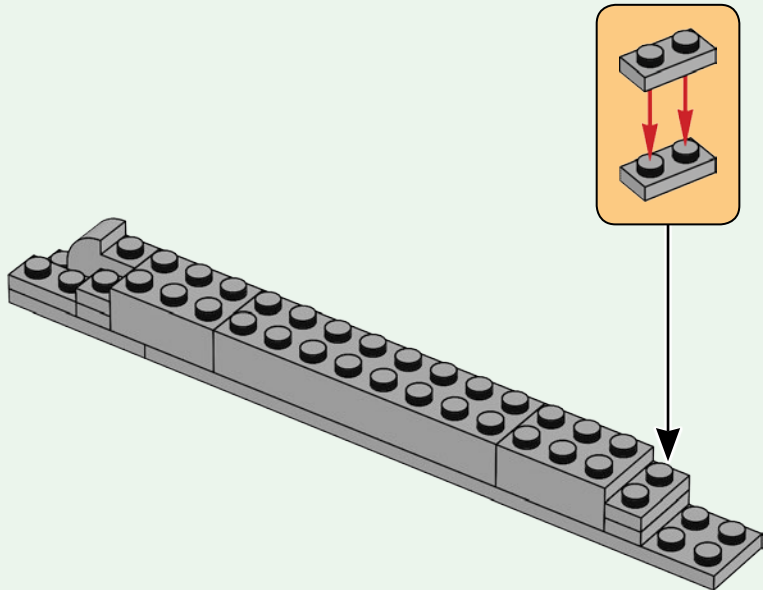

162

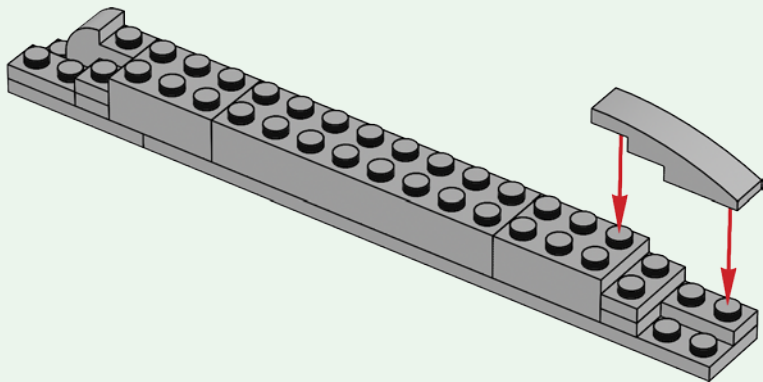

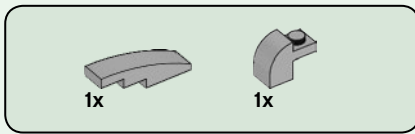

163

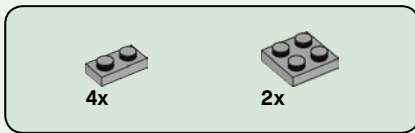
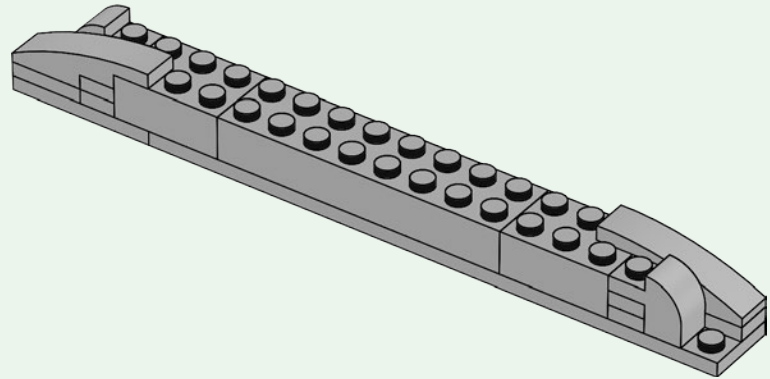

164

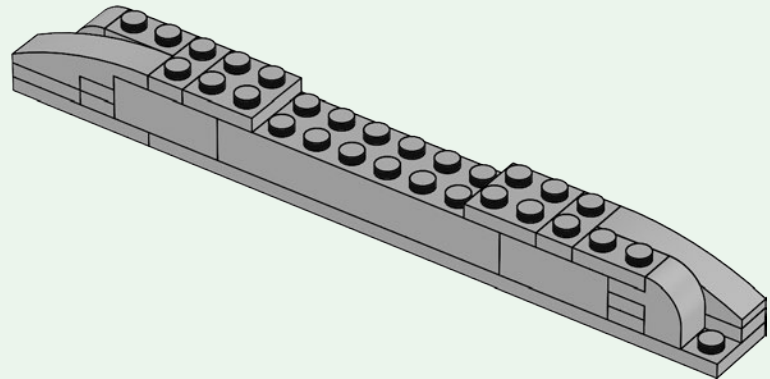

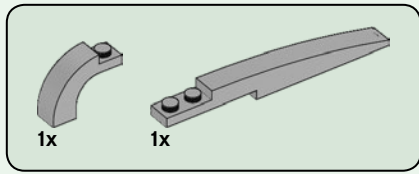

165

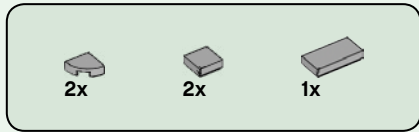
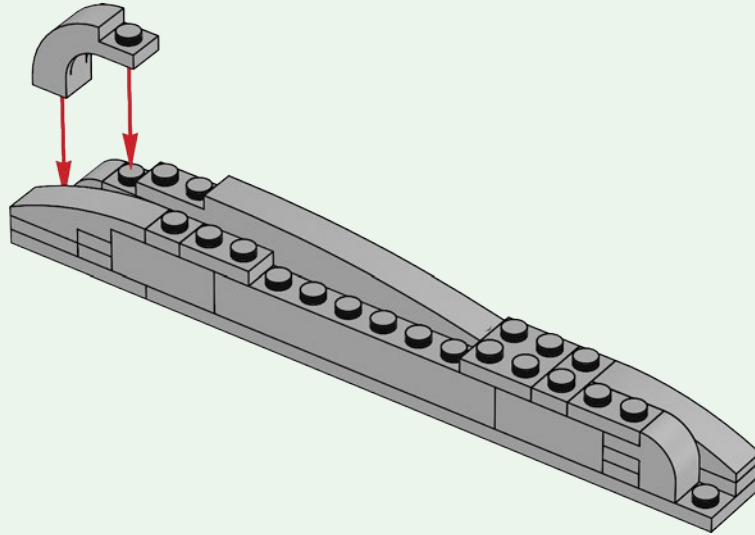

166

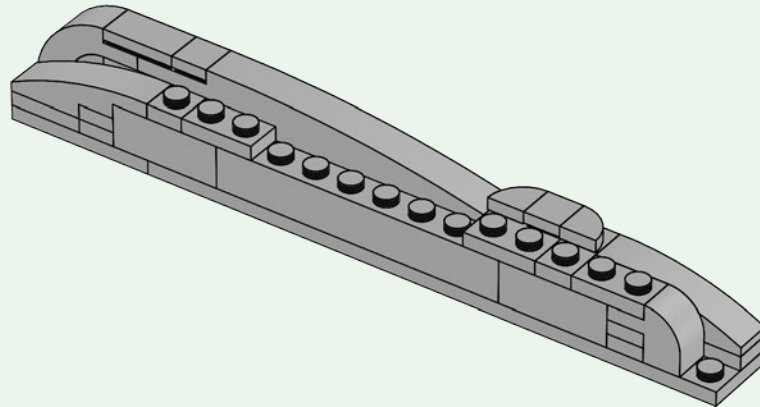

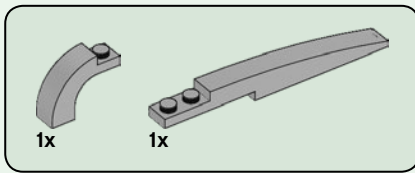

167

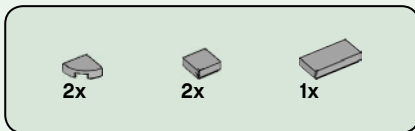
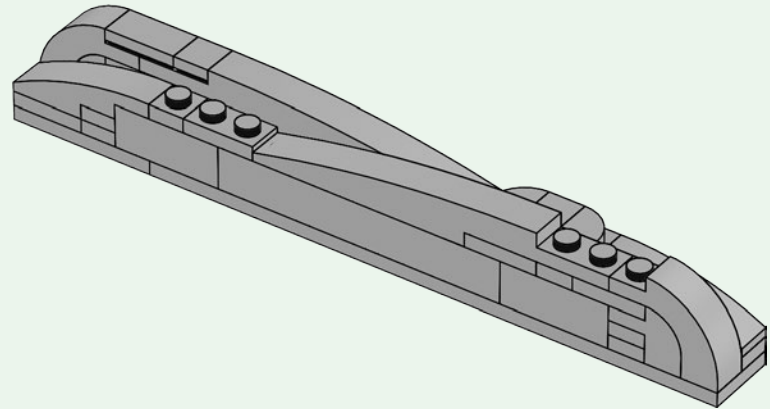

168

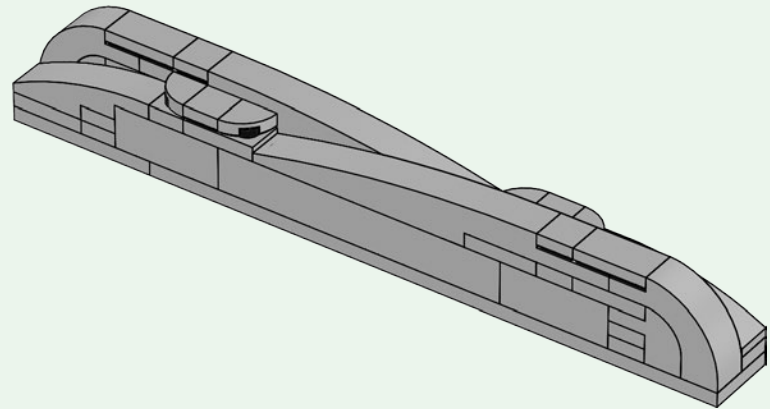

169

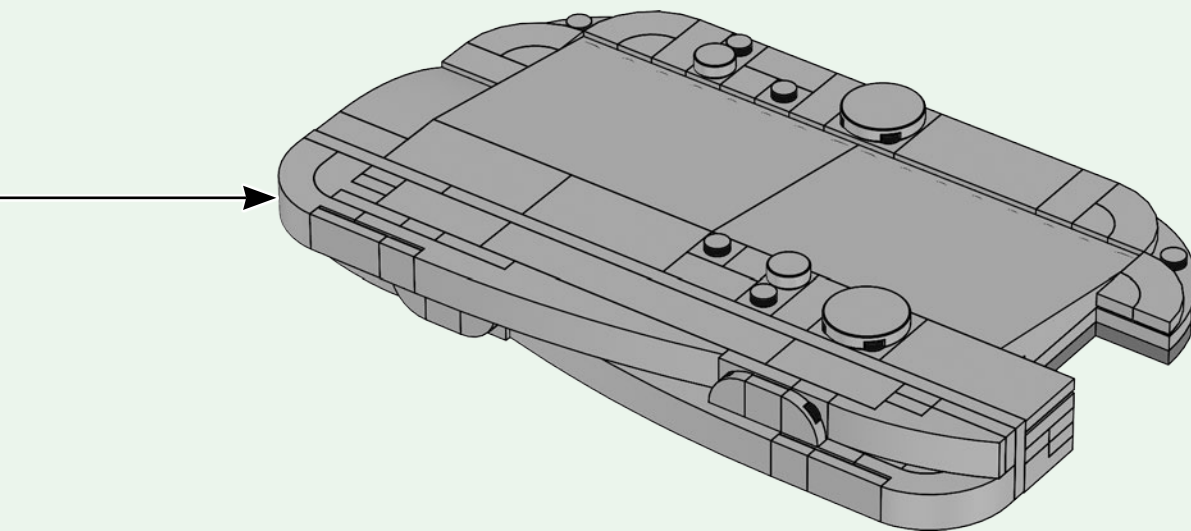

170

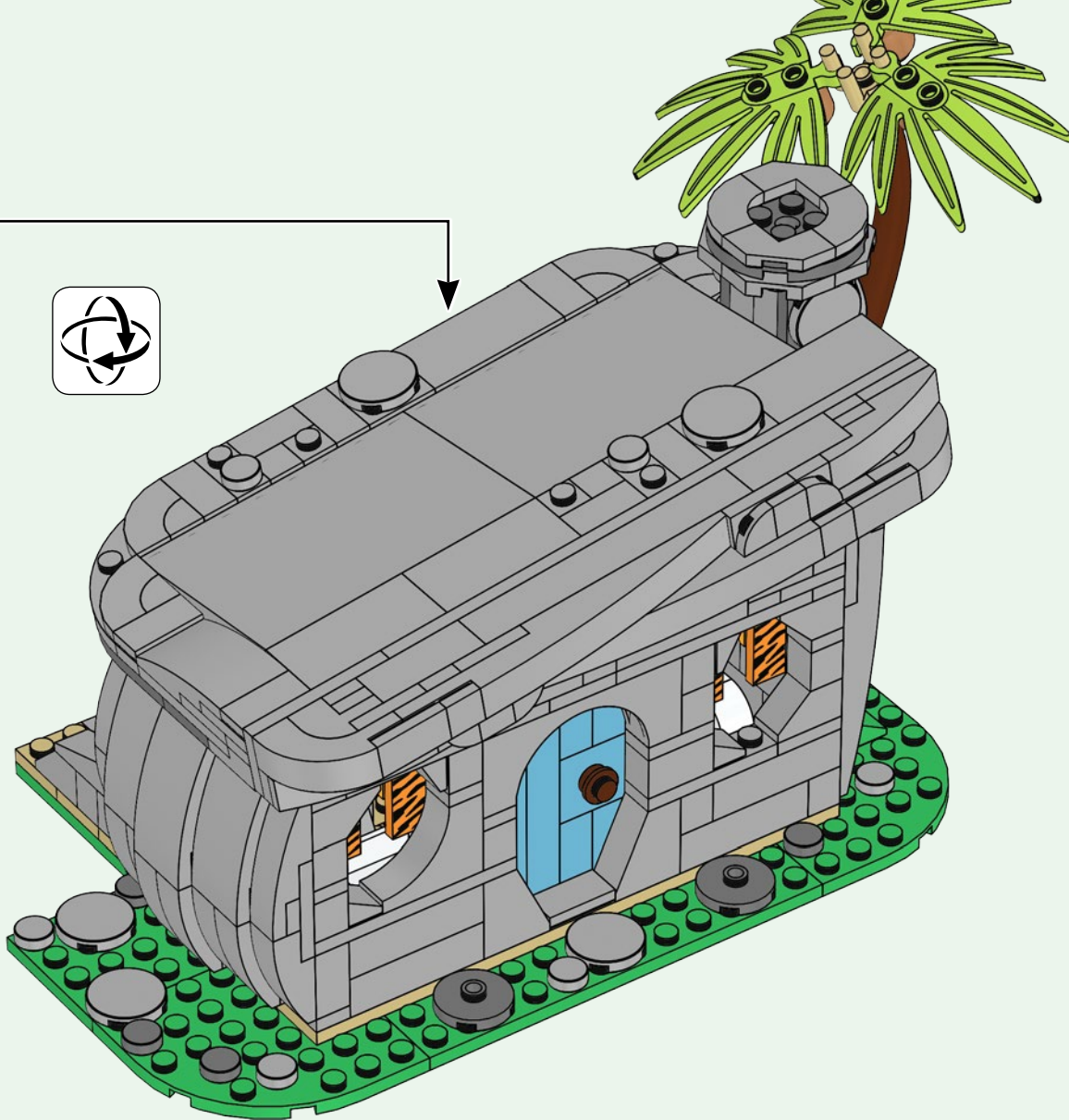



5x

171



174

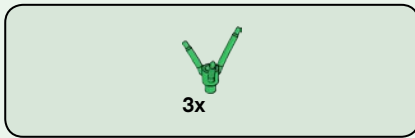

172



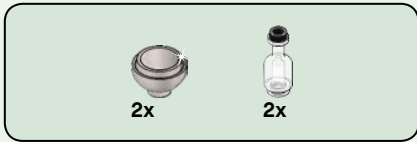



173



176

- 4x 
- 4x 
- 4x 

174

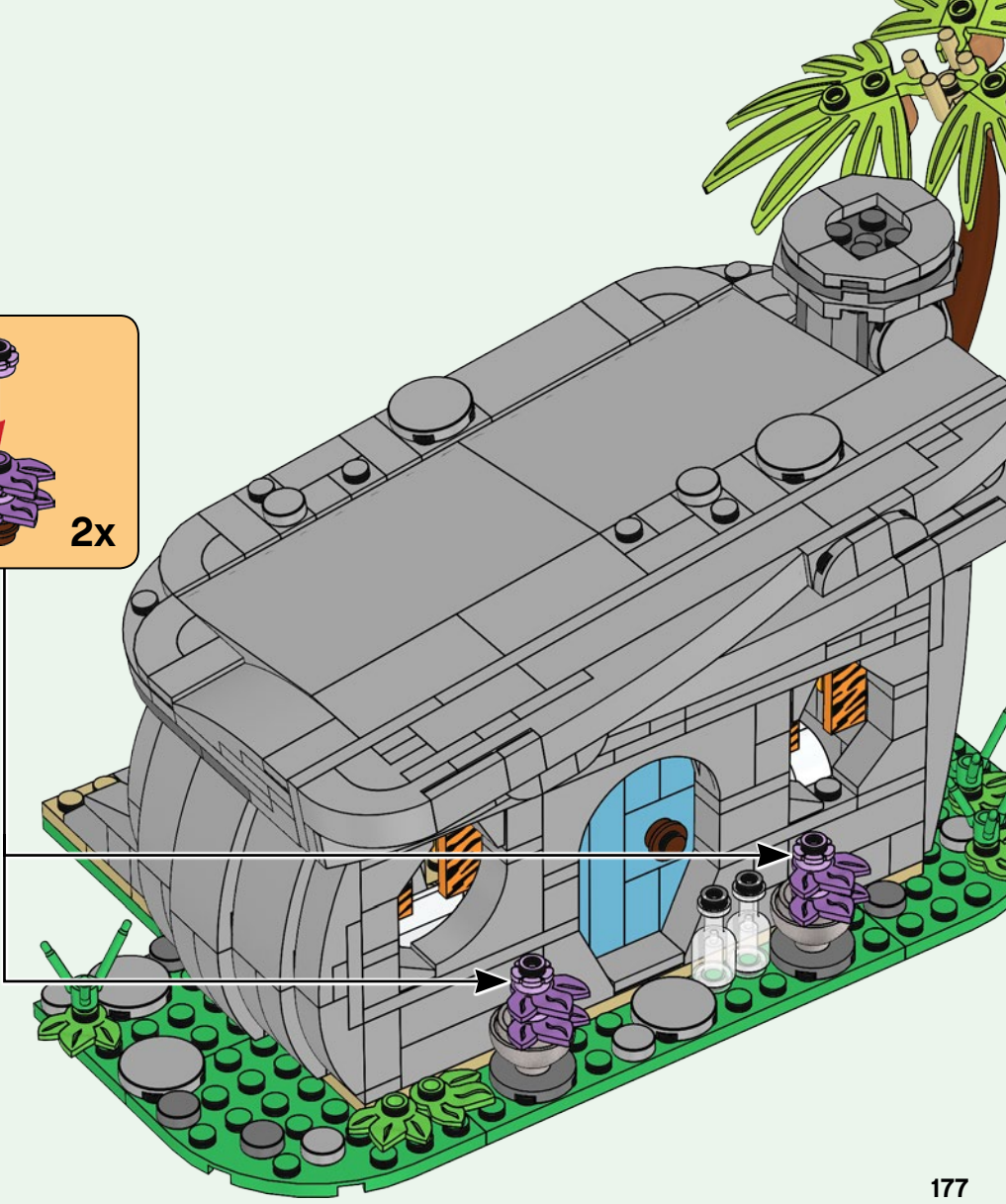
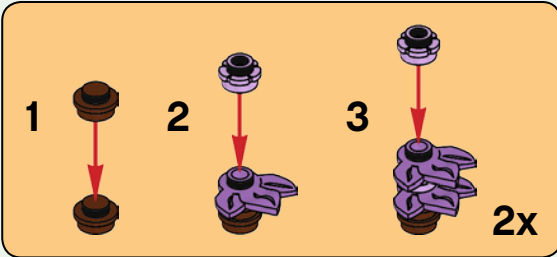

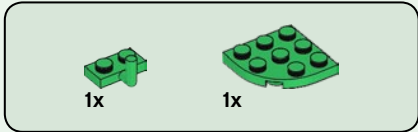

1

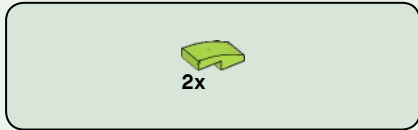
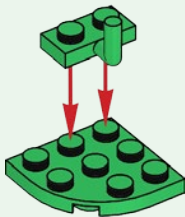

2

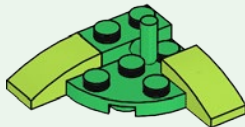



3

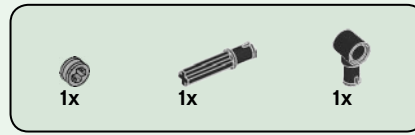
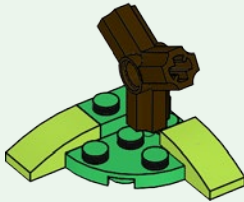

4

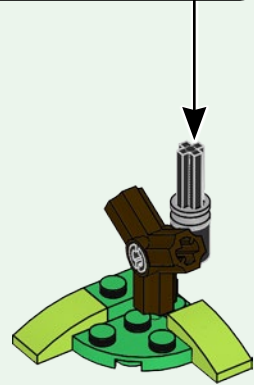
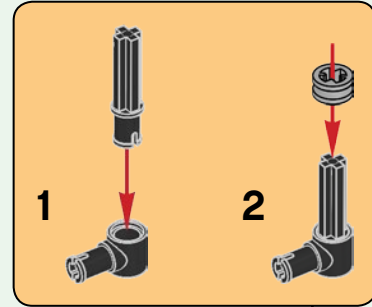

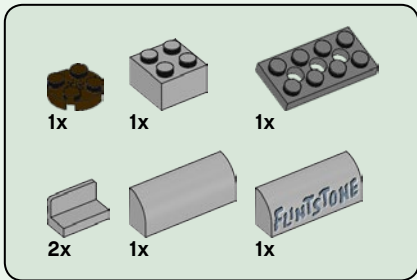

5

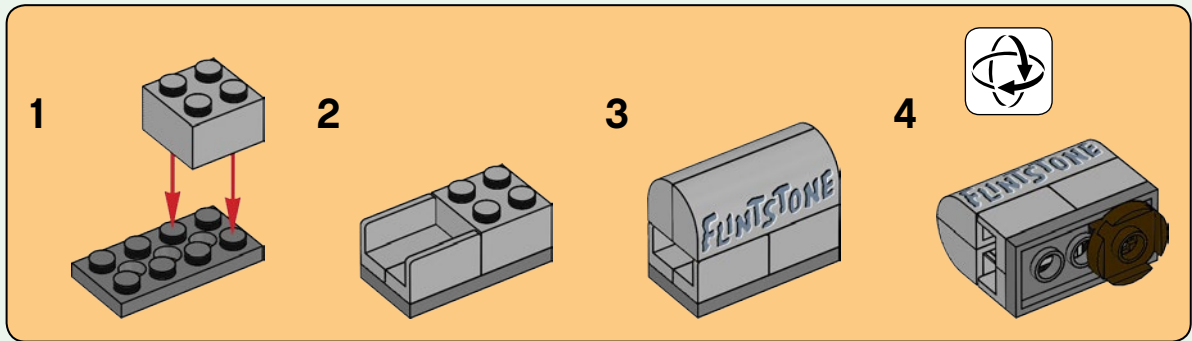

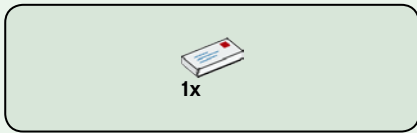

6

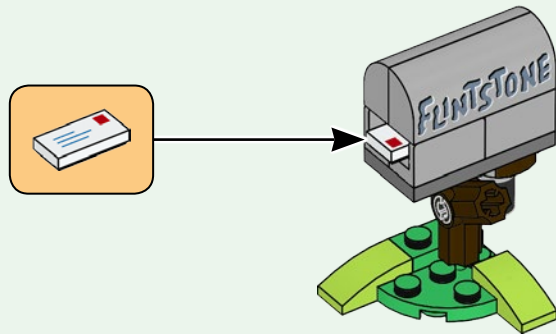



IDEAS

GATHER SUPPORT
OBTIENS DE L'AIDE
OBTÉN APOYOS



SHARE YOUR IDEA
PARTAGE TON IDÉE
COMPARTE TU IDEA

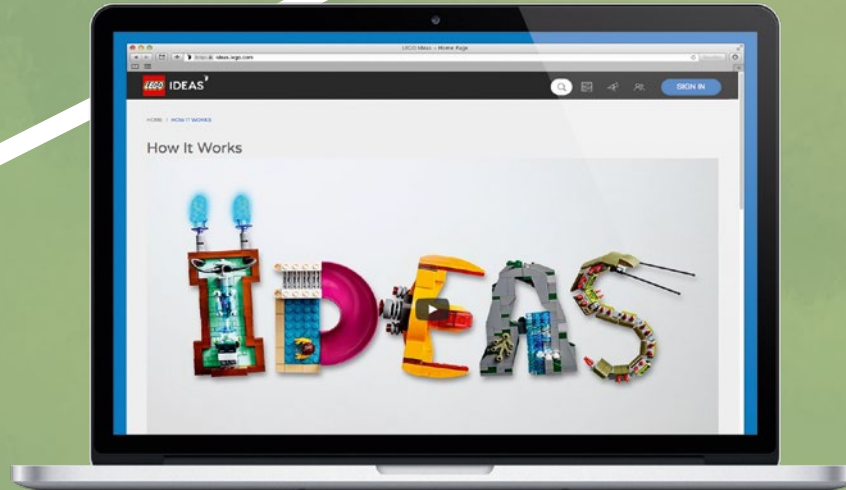

NEW LEGO® PRODUCT
NOUVEAU PRODUIT LEGO®
NUEVO PRODUCTO LEGO®

LEGO® REVIEW
EXAMEN LEGO®
REVISIÓN DE LEGO®



TM & © World Events Productions, Ltd. Under license to Classic Media, LLC.

[LEGO.com/ideas](https://www.lego.com/ideas)



1









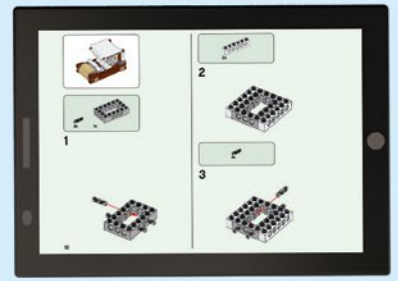









































































































2



3



 3x 6194512	 2x 6051511	 4x 362301	 1x 6143062	 3x 6223427	 4x 6145215	 1x 6265475	 1x 6265027
 5x 306201	 3x 393801	 1x 4143254	 3x 4114084	 1x 6100565	 1x 6220715	 1x 6265475	 1x 6265038
 10x 614101	 4x 609101	 1x 243101	 2x 4114084	 1x 302321	 1x 4593773	 1x 6265284	 1x 6265052
 4x 302401	 3x 302301	 2x 301001	 11x 4114309	 3x 6019155	 1x 6267065	 1x 6265292	 1x 6265054
 4x 407001	 3x 393701	 3x 371001	 4x 6232142	 1x 302221	 4x 6266180	 1x 6267727	 1x 4183133
 1x 300501	 4x 306901	 2x 6104805	 2x 4114001	 1x 302121	 1x 6265476	 1x 6267727	 1x 6087084
 1x 307001	 1x 4521848	 1x 6223667	 2x 4113988	 2x 6132777	 1x 6265476	 1x 6265302	 2x 6069006
 2x 623101	 3x 6248827	 1x 6147792	 2x 4113988	 1x 6177146	 3x 4629994	 1x 6265483	 3x 6023832
 1x 6242241	 2x 4598527	 1x 6147792	 2x 4113988	 1x 6177146	 2x 6215606	 1x 6265483	 5x 6182261
 1x 6058250	 3x 6093526	 1x 366601	 1x 6030980	 1x 6177146	 2x 6215606	 5x 6097419	 5x 6182261
 4x 403201	 2x 6218822	 2x 389401	 1x 6266291	 2x 6215606	 4x 4649741	 5x 6097419	 2x 6000071
 1x 6093053	 2x 4515364	 1x 663601	 1x 6266291	 2x 6215606	 4x 4649741	 1x 6126090	 3x 6135278
 1x 6146215	 2x 4515364	 1x 663601	 1x 6266291	 2x 6215606	 4x 4649741	 1x 6126090	 3x 6135278
 2x 73737	 1x 6188466	 2x 379501	 2x 6132772	 2x 6215606	 1x 6035734	 2x 6185309	 1x 6039946



2x
6240218



3x
6102756

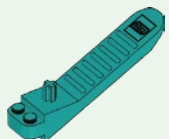

1x
6254100



1x
6062166



2x
6021999

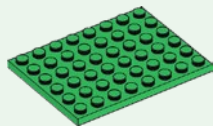

2x
4507311

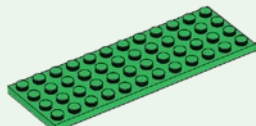

2x
4279059

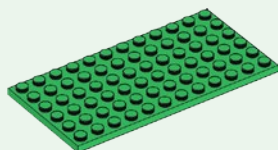

1x
6177783



1x
4623298



1x
4623298



1x
6005755



1x
6005755



2x
6170468



8x
4216581



2x
6186673



2x
4221744



4x
4211288



5x
6182435



1x
6102360



2x
6069984



5x
6173132



4x
4211150



6x
6008297



1x
6196221



2x
6045941



6x
4211190



2x
4211204



1x
4243838



2x
4211247



1x
6175223



2x
4585337



2x
4223683



1x
4290713



1x
6073231



1x
6262019



4x
4517925



10x
4121715



2x
6155068



2x
6089119



1x
6135555



2x
6247369



19x
4650260



1x
4211573



24x
6250597



17x
6052200



14x
4211399



8x
6176433



9x
4521921



4x
4558953



6x
4211415



12x
4211389



2x
4541978



1x
6225246



1x
4533772



2x
4211475



1x
6028324



4x
4568637



2x
6015344



1x
6183782



1x
4211814



2x
4211437



37x
4211398



4x
6186657



2x
4515374



2x
6146223



2x
4211519



10x
4211388



1x
4211440



2x
6011459



14x
4211414



3x
4211614



16x
6123809



2x
4211364



1x
4667578



2x
4211461



4x
4211397



1x
6185676



2x
6212077



7x
4211413



6x
6163990



5x
4211353



2x
6177078



1x
4211429



1x
4211387



8x
4654577



2x
4625619



4x
6167798



11x
4251163



1x
6129340



1x
6093870



4x
4211396



2x
4211386



11x
4211394



2x
4211445



5x
4622742



4x
4560183

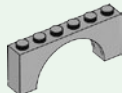

1x
6106189



3x
6013497



14x
4211438



2x
4579294



5x
4211452

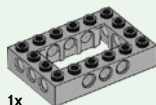

1x
4211716



1x
4211636



4x
6042950



1x
6266195

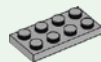

6x
4211395



1x
4211435



1x
6195463



1x
6266185



1x
6266192

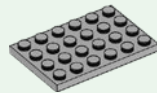

1x
4211404

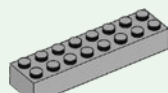

1x
6037399

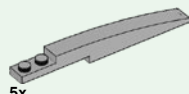

5x
6037667

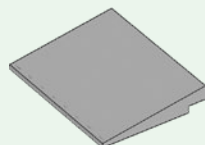

2x
4211819



2x
4211860

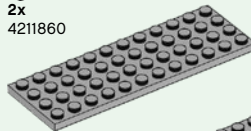

1x
4211401

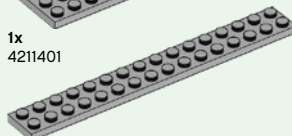

2x
4211486



2x
4257526

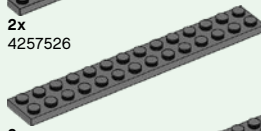

3x
6000970

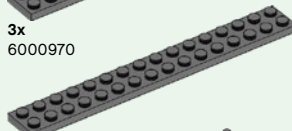

1x
4210796



1x
4211056



1x
4222042



1x
4500517



1x
4528323



1x
6170420



4x
4210633



5x
6222416



1x
6231765



3x
4278274



2x
4210695



1x
6055313



3x
4567887



1x
4211010



2x
6115080



5x
4211063



2x
6000606



9x
4211094



1x
4568734



2x
4210882



1x
4211001



1x
4211043



1x
4227398



1x
6170486



1x
6262020



2x
370024



2x
306223



1x
614123



6x
4143005



1x
403223



4x
6214235



4x
6210460



1x
4619516



1x
4653960



4x
6031821

Customer Service
Kundenservice
Service Consommateurs
Servicio Al Consumidor
LEGO.com/service or dial



: 00800 5346 5555

: 1-800-422-5346



IDEAS

Do you like this LEGO® Ideas set?

The LEGO Group would like your opinion on the new product you have just purchased. Your feedback will help shape the future development of this product series.

Please visit:

[LEGO.com/productfeedback](https://www.lego.com/productfeedback)

By completing our short feedback survey, you will be automatically entered into a drawing to win a LEGO® prize.

Terms & Conditions apply.



Aimez-vous cet ensemble LEGO® Ideas ?

Le Groupe LEGO aimerait connaître votre opinion sur le produit que vous venez d'acheter. Vos commentaires nous aideront à concevoir les futurs produits de cette gamme.

Veuillez visiter :

[LEGO.com/productfeedback](https://www.lego.com/productfeedback)

En remplissant ce court sondage sur le produit, vous serez automatiquement inscrit à un tirage au sort pour gagner un prix LEGO®.

Des conditions s'appliquent.

¿Te gusta este set LEGO® Ideas?

The LEGO Group quiere conocer tu opinión acerca del nuevo producto que acabas de comprar. Tus comentarios nos ayudarán a dar forma a los futuros productos de esta serie.

Visita:

[LEGO.com/productfeedback](https://www.lego.com/productfeedback)

Al contestar este breve cuestionario de opinión, participarás automáticamente en el sorteo de un producto LEGO®.

Sujeto a términos y condiciones.



THE FLINTSTONES and all related characters and elements © & ™ Hanna-Barbera. (s19)
WB SHIELD: TM & © WBEI. (s19)

6277293